

# **A Palimpsest Design Approach to Adaptive Reuse of Gas Stations**

by

Zishi Liu

Submitted in partial fulfilment of the requirements  
for the degree of Master of Architecture

at

Dalhousie University  
Halifax, Nova Scotia  
March 2023

Dalhousie University is located in Mi'kmaq'i,  
the ancestral and unceded territory of the Mi'kmaq.  
We are all Treaty people.

© Copyright by Zishi Liu, 2023

# Contents

Abstract .....	iv
Acknowledgements .....	v
Chapter 1: Introduction .....	1
Background .....	1
Our Temporary Nature .....	1
Global Decline of the Gas Station.....	5
Context .....	8
Shifting Demand Renders Single-Objective Architecture Obsolete .....	8
Single-Objective Buildings Don't Adapt, Leading to Abandonment and Demolition .....	9
The Consequences and Effects of Building Demolition .....	11
Chapter 2: Questions and Issues .....	13
Factors to which Architecture Needs to Adapt.....	13
Natural Factors .....	13
Demographic Factors .....	14
Cultural Factors .....	14
Political Factors .....	14
Economic Factors .....	15
Architecture Is Not a Static but a Participant.....	15
Why Is It a Challenge for Architecture to Adapt? .....	18
Technological Factors .....	18
Money.....	19
Fashion.....	19
Chapter 3: Method: Theories and Data Analysis .....	20
Research: Theories and Case Studies.....	20
Quick Summary .....	20
Case Studies .....	24
Theories Review and Reflection .....	35
Data Collection and Analysis .....	43
Data Collection Framework .....	43
Data Mapping and Visualization .....	44

Chapter 4: Design Project .....	48
Design Concept .....	48
Trace—Palimpsest .....	48
From Plug-N-Go to Plug-N-Play .....	49
Design Approach .....	51
Time-Phased Design .....	51
Development Process.....	52
Project Development .....	54
Phase 1: Remediation .....	54
Phase 2: Urban Park (Meet Each Other ).....	59
Phase 3: Community Learning Center (Learn from Each Other ).....	61
Phase 4: Localized Clinic (Take Care of Each Other ).....	64
Phase 5: Future Beyond .....	67
Project Sequences .....	69
Project Sequences in Sections.....	73
Chapter 5: Conclusion .....	74
References .....	77

## **Abstract**

Buildings are designed for social demands, but social demands change faster than our buildings can adapt, leading to a repeating cycle of construction and demolition. This cycle causes not only negative environmental impacts but also cultural ones. The concept of adaptive architecture is not new; many have studied, examined and responded to this topic from different angles, including structuralism, cybernetics, metabolism, and open building theorists. This thesis reviews previous theories, combines their strengths and avoids their weaknesses. Then, this thesis will apply the theoretical methods to a case study in the form of a gas station in Vancouver, British Columbia. Ultimately, The design will reflect the community's needs by analyzing the latest social data and take a design-in-time approach to convert the decommissioned gas station into a decentralized community health center through a series of interventions in time to adapt to the community's future needs.

## **Acknowledgements**

I would like to thank my supervisor Michael Putman and advisor Ted Cavanagh for all their help and all the constructive and inspirational discussions about this thesis project. My Family for their support over the years.

# Chapter 1: Introduction

In this thesis, I ask how architecture can be designed through a time-phased architectural design approach that adapts to our fast-changing society. It takes a hybrid approach by first studying architectural theories on this topic, including structuralism, cybernetics, metabolism and open building/ shearing layers, and using their strengths and minimizing their weaknesses. Additionally, I analyze the latest data on social changes to prepare the project for future changes. Then I apply the time-phased design approach to a case study in the form of a gas station in Vancouver, British Columbia, through a series of interventions in time without erasing the existing structure.

## Background

This section will discuss critical concepts, such as humans' temporary nature, the cone of uncertainty and the uncertainty paradox. Those concepts do not directly connect to architecture, but they are essential to the development of the thesis.

## Our Temporary Nature

Human beings are temporary by nature. We are born, live for a certain amount of time, and then fade. This temporality is a fundamental aspect of the human experience, and it is something that has been recognized and reflected upon throughout history (Ikeda, Simard, and Bourgeault 2003, 125). It is a reminder that everything in the world is fleeting and nothing stays the same forever. The temporality of life has been explored in various philosophies and religions and is a common literary theme. One of the critical insights of the idea of the temporary nature of life is that it encourages

us to live in the present moment. Humans are constantly moving forward in time, and the future is unknown.

An example of this can be found in the ancient Chinese text, “Tao Te Ching,” which teaches the concept of wu-wei, or non action. This concept is about embracing the present and not trying to control or change the natural flow of things (Schneider 2019). It advocates for a simple and natural way of living, where one does not cling to the past or attempt to predicate the future but embraces the unknown by being open-minded and receptive.

The temporality of nature is closely linked to the idea that the only constant is change. This view of impermanence is widely shared among many Eastern cultures. For example, Rem Koolhaas investigated the difference between European and Japanese architectural approaches and noted that Japanese architect Kisho Kurokawa, designer of the Nakagin Capsule Tower, said, “Everything we see is impermanent. Whole cities can vanish in a day of warfare. It’s this idea that the Japanese believe in, not the outward form . . . But what’s important here is that we conceive of our tradition and philosophy as invisible, which is very different from Europeans” (Koolhaas 2011, 385).

This idea that the only constant in life is change can be seen in the famous quote by the Greek philosopher Heraclitus: “No man ever steps in the same river twice, for it’s not the same river and he’s not the same man” (Heraclitus 1991, 18). Everything changes over time, whether natural, social or personal. In the natural world, change is a fundamental aspect of the universe. The earth constantly changes, with seasons coming and going, weather patterns shifting and geological processes reshaping the landscape. In the social

world, change is also constant. Societies, cultures and technology are constantly evolving, and what is considered normal or acceptable today may differ in the future. Finally, people's lives are full of change as they go through stages of life, experience new things, and make choices that alter the course of their lives. Therefore, one needs to accept and even embrace change as a part of the process.

However, humans often fear what they do not know. Thus, they attempt to predicate the future based on the past or the current situation (Ikeda, Simard, and Bourgeault 2003, 125). Although history is consistently hailed as a great teacher that society must study to prepare for the future, the past is no guarantee of what will occur in the future. Generally, humans want to know what will happen in the future, and studying the past provides a sense of security. However, it is not necessary to know what the future will be or the direction the future will take. American writer Isaac Asimov once said, "You don't need to predict the future. Just choose a future—a good future, a useful future—and make the kind of prediction that will alter human emotions and reactions in such a way that the future you predicted will be brought about. Better to make a good future than predict a bad one" (Asimov 2004, 171).

## **The Uncertainty Paradox**

### ***The Cone of Uncertainty/Plausibility***

The cone of uncertainty/plausibility (Diagram below) is used in the field of future thinking. It is not a foresight method but is often used as a teaching tool (Swanson 2021). It does not have a direct connection with architecture, but it is a powerful tool to represent and visualize the unknown of the future. The horizontal axis represents time from the current



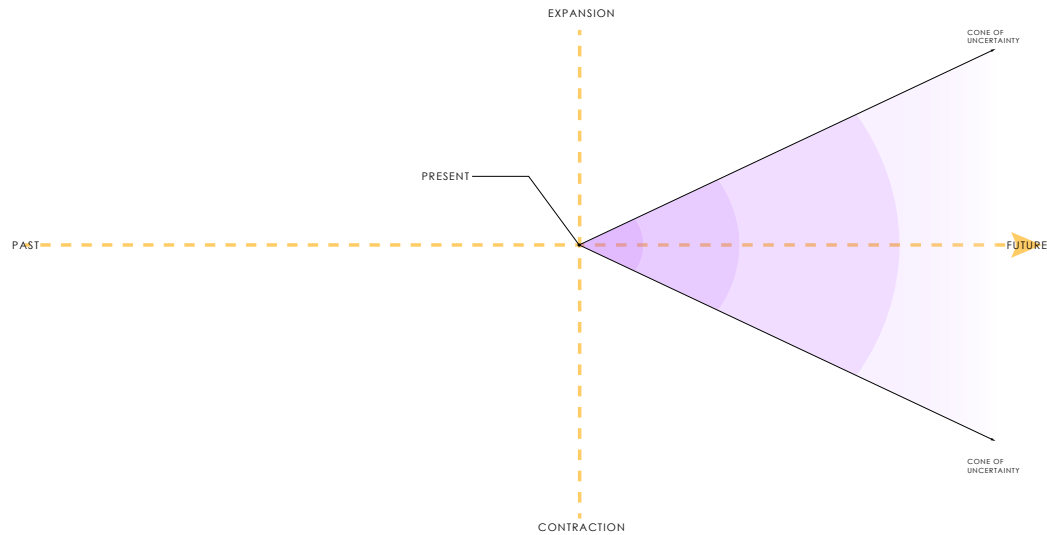

Jason Swanson, cone of uncertainty/plausibility diagram, 2021 (Swanson 2021)

moment to the future. The vertical axis is the possibility of an event. This diagram illustrates the idea of the future is not one but many. The future could fall any place within the cone of uncertainty, and some scenarios are more plausible than others. Furthermore, as time moves further from the present, the cone of uncertainty expands larger because the further we look into the future, the more unpredictable it is.

The cone of uncertainty/plausibility also reveals the uncertainty paradox: the phenomenon in which society tends to be overconfident in its beliefs. This paradox arises because uncertainty and ambiguity are pervasive in everyday life, yet people often make decisions and take action based on limited information. Thus, despite the inherent uncertainty and complexity of the world, society misinterprets what is happening now as what will happen in the future because of confirmation bias based on the current evidence (Asselt and Ellen 2006, 5).

The uncertainty paradox highlights the complex interplay among uncertainty, confidence and action in human decision-making. It suggests that it is crucial to balance

cautiousness and optimism when navigating the uncertain and unpredictable world. For example, many economists and financial analysts attempt to predict economic trends, such as stock market fluctuations or the direction of interest rates, even though the economy is a complex and dynamic system with many unpredictable factors, such as political events, natural disasters, technological advances and global economic trends. Despite this uncertainty, analysts and investors often make bold predictions and act on them, sometimes with significant consequences.

One of the best examples of this phenomenon is the gas stations' extreme boom and decline cycle in the past century in North America. Because of its relatively low cost, abundance and efficiency, fossil fuel became the dominant energy source during the Industrial Revolution. Furthermore, society's reliance on fossil fuels was solidified after World War II, fueled by the population boom and increasing ownership of personal vehicles. Major infrastructure projects and supporting structures, including drive-through restaurants, movie theatres and gas stations, were constructed across the continent (Jansen and Kathleen 2022). However, international society started realizing the true cost of fossil fuel, which appears cheap to produce but has caused irreversible damage to our planet. As a result, society began to look for an alternative and urged a drastic shift from its overreliance on fossil fuels.

### **Global Decline of the Gas Station**

Gas stations experienced a boom in number from the early 1900th to the new millennium, but now their numbers are drastically declining. Because of society's overreliance on fossil fuels in the past, gas stations can be found in almost

every city worldwide. With the change of time, gas stations evolved. Initially, gas stations were places to refill and repair between destinations, but today many gas stations serve as a multifunction space, serving as a refilling space, car wash, convenience store and rest stop. Gas stations are a critical part of industrial history and our daily lives.

However, despite the recent resurgence in gas prices, the global decline of gas stations has continued (Jansen and Kathleen 2022). The number of gas stations worldwide has declined by 4.5 percent over the past year, and this trend shows no signs of stopping. Rising operating costs and the shift to electric vehicles are just two factors in the decline. According to the 2019 Global Gasoline Station Database from Shell Oil Company, there are 166,794 gas stations in the United States alone. Although this is a 3 percent increase from last year, it is still well below the peak of 173,046 stations in 2000. The same trend also shows in Canada. There were over 20,000 gas stations in the 1970th, which has dropped to around 12,000 today nationwide. Moreover,

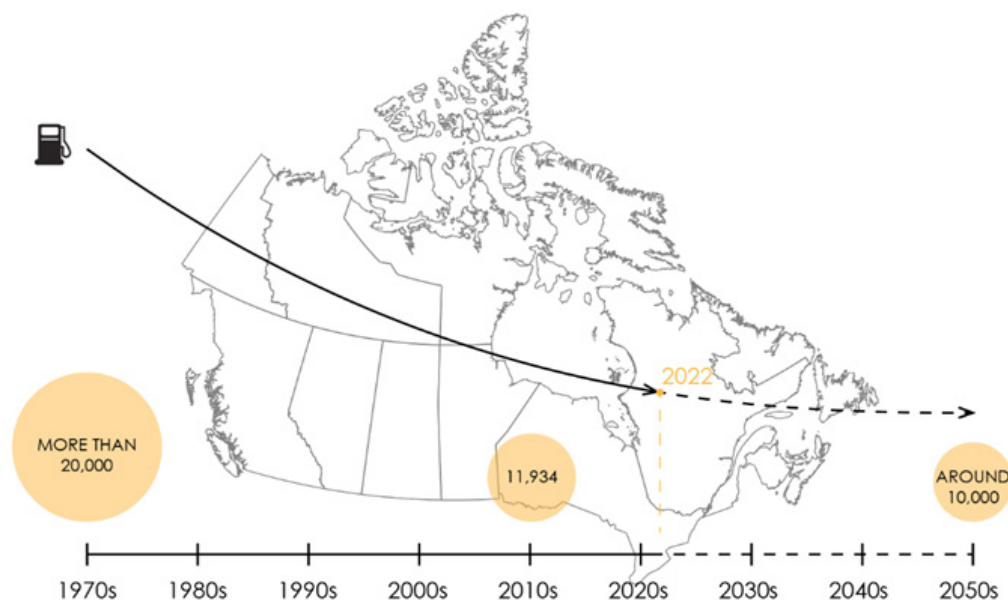

The decline of gas stations in Canada from the 1970th to 2010th and future projection. (Data from CAPP 2020)

the prediction is that fewer than 10,000 gas stations will remain by 2050 (CAPP 2020).

Vancouver once had the most gas stations in Canada, and today it has the highest decline rate for gas stations among all Canadian cities. Vancouver is also where the first gas station in Canada is located. According to the Canadian Fuel Association, there were 244 gas stations in the metro Vancouver area in 1970, and by the early 2010th, only 84 were still in service. As of 2022, only 49 gas stations remained, and only one is located in downtown Vancouver (Map below).

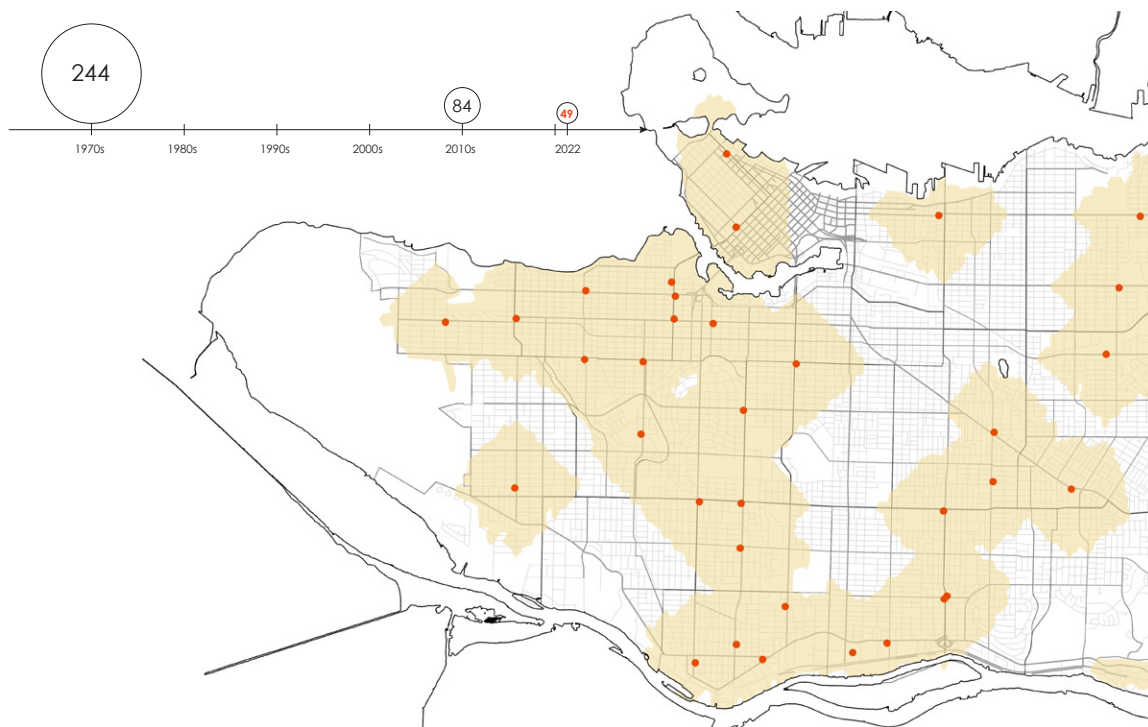

Map of decommissioned Vancouver gas stations in the last six years (Data from CAPP 2020)

As a result of this decline, more brown sites resulting from decommissioned gas stations have occurred around the country. This raises the question of what society could do with such station and whether we could repurpose gas stations. However, repurposing gas stations comes with challenges, the biggest of which is petroleum contamination.

## **Context**

### **Shifting Demand Renders Single-Objective Architecture Obsolete**

Architecture is a reflection of the way we work and live. As Louis Sullivan says, “Form follows function.” In architecture, buildings and other structures are often designed to meet specific needs and serve specific functions. For example, a hospital is designed to provide medical care and hold a specific amount of patients, whereas a stadium is designed to host sports and other large events. Single-objective buildings are becoming obsolete for several reasons, including rapid changes in society and technology. As society evolves, the demands placed on buildings also evolve. For instance, with the evolution of technology, people’s work and communication patterns are changing, which can make architecture designed for traditional office work obsolete. Similarly, as the population grows, urban areas may change, and buildings in those areas may no longer be in the best location for the new pattern of use or population density and function (Chan 2022). Other structures, such as retail shops, may become less common thanks to the rise of online shopping. The architecture of these buildings would no longer be efficient for their intended purposes. Moreover, their current form limits their future adaptive possibilities. It is difficult to convert those buildings and structures to new trends (Pourebrahimi, Eghbali, and Pereira Roders 2020, 636).

Overall, single-objective buildings are becoming obsolete given a rapidly changing society and technology, consumer behaviours, the growing focus on sustainability and the impact of climate change. Architects and designers

should consider the potential for changing demands when designing new buildings and structures so they can create architecture that will be easier to adapt as needs change. As Stewart Brand points out in his book *How Buildings Learn*: “To change is to lose identity; yet to change is to be alive” (Brand 2015, 342).

### Single-Objective Buildings Don’t Adapt, Leading to Abandonment and Demolition

Technological improvements, changes in building codes and regulations, alterations in taste and fashion and changes in people’s needs and demands can lead to a building’s obsolescence. Currently, such changes are happening quickly, causing many buildings to be at risk of obsolescence. Obsolescence shortens the useful life of buildings and, in many cases, can lead to the premature demolition of a building while its physical and structural soundness would otherwise continue (Muresan et al. 2020, 3).

According to Jan Brütting, among 193 surveyed buildings, the average lifespan of a building is around forty years

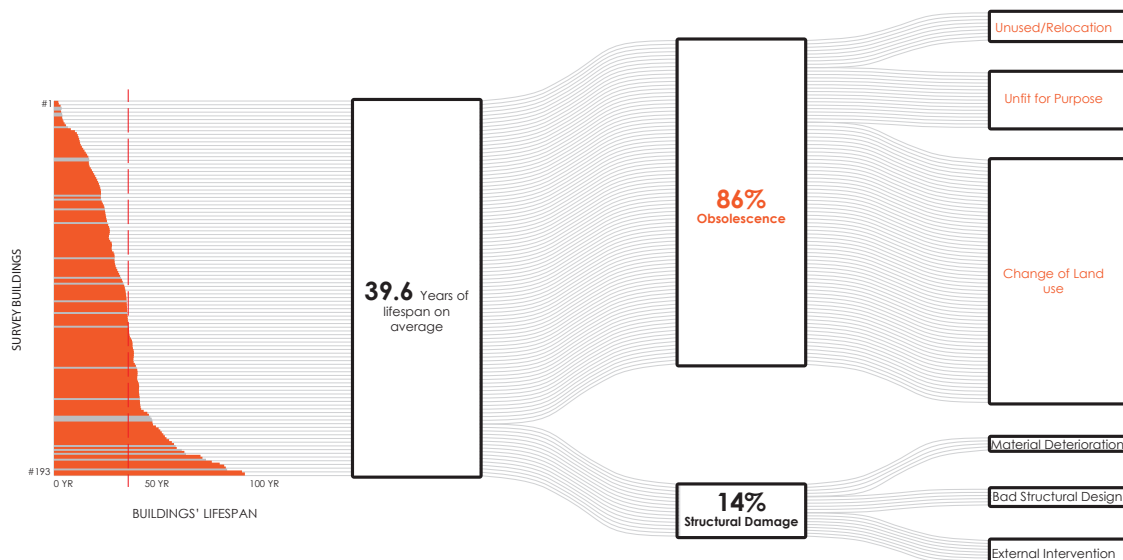

Average lifespan and reasons for demolition between 192 surveyed buildings (Data from European Environmental Agency, National Footprint Accounts 2018)

before they are demolished, 86 percent of demolitions are caused by obsolescence, and only 14 percent of buildings are demolished due to structural reasons, shown in chart above (Muresan et al. 2020). In other words, buildings get demolished because they cannot adapt to the community's changing needs. A building's purpose is determined by its design, which is impacted by the specific objectives of the architect or builder. In short, the form of a building follows its function. However, as our needs and desires change over time, the functions of our buildings must adapt as well.

Most buildings are single-objective, which means they cannot effectively serve to changing needs and so are prone to abandonment and demolition. Dutch architect Herman Hertzberger comments in *Architecture and Structuralism: The Ordering of Space*:

In general, the useful life of a building is getting increasingly shorter; it is only with open-ended strategies comparable to those with which cities manage to avoid chaos that buildings can be conceived in such a way that they are adaptable for other functions. In other words, buildings should be less geared to a single objective and made more sensitive to the influence of what user and occupants introduce out of a commitment to their living and working environment. (Hertzberger 2015, 72)

This issue of buildings' ability to adapt exists not only in commercial buildings, but also in the residential sector. According to Canadian national records of building permits,

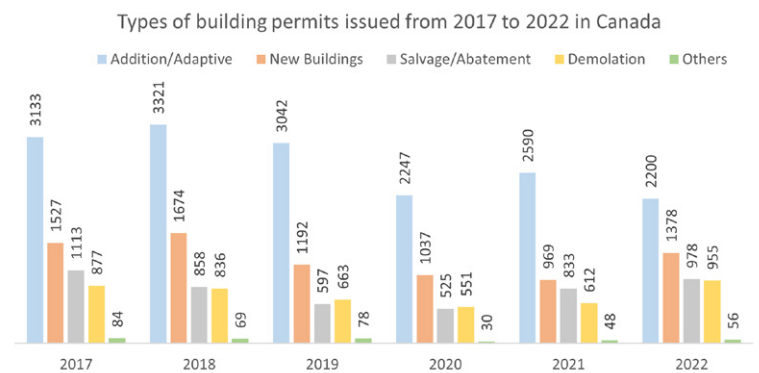

Types of building permits issued between 2017 and 2022 in Canada. (Data from Statistics Canada 2021)

in the past six years, the most issued building permit type was not the new build but addition/alteration.

### **The Consequences and Effects of Building Demolition**

The cycle of demolishing and rebuilding is a common phenomenon in architecture and construction, and this constant cycle is not free of consequences. The cycle requires heavy machinery and often generates a significant amount of waste materials, such as concrete and steel. Additionally, rebuilding a new structure requires using new resources, such as raw materials and labour (Smith 2006, 4). The process often produces pollution and emissions that harm the environment. According to a study by the Global Footprint Network: Today, worldwide annual resource consumption is 1.7 times greater than what the planet can sustainably provide, while the construction industry is responsible for 35% of all materials used. The trend is expected to increase as it is projected that by 2050 about two-thirds of the world's population will live in urban areas. As a consequence, in cities the value of land will rise, putting economic pressure on existing buildings and increasing their obsolescence risk. This leads to more buildings being demolished and replaced for new functional requirements, meanwhile generating large amounts of construction and demolition waste. Already today, more than 30% of total global waste is attributed to the construction industry (Ecological Footprint 2022).

Second, one of the most notable environmental impacts of demolishing buildings is the loss of carbon sequestration. Buildings, particularly those made of wood and other natural materials, act as carbon sinks, absorbing and storing



carbon dioxide from the atmosphere. When a building is demolished, the carbon stored in the building is released back into the atmosphere, contributing to climate change (Smith 2006, 5).

Demolishing and rebuilding can also have a detrimental effect on the economy. Demolishing a building takes away jobs and revenue from the community. Similarly, building new structures can be costly and may not provide the same economic benefits as investing in existing buildings. The cycle of demolishing and rebuilding is also expensive for building owners. Every time a new building is built, the cost of materials and labour increases because demand is typically high, and the supply of materials and workers is usually limited.

Demolishing and rebuilding may also involve the loss of cultural and historical heritage. Many old buildings have significant historical or cultural value and are important to communities. Demolishing these buildings destroys a valuable piece of history and erodes a community's cultural identity.

In conclusion, the cycle of demolishing and rebuilding causes a waste of resources and can negatively affect the environment, economy and cultural heritage. Instead, society should focus on preserving, retrofitting and repurposing existing buildings to provide sustainable and cost-effective solutions. Architects, urban planners and policy makers can play essential roles in promoting this approach and protecting our built environment.

## Chapter 2: Questions and Issues

As Chapter 1 pointed out, architecture is often demolished wastefully because buildings fail to adapt to the changes of time, the environment, the economy and culture. Therefore, to minimize the damage, architecture must be able to adapt. According to Norman Foster, "The ultimate sustainable building is a building that you can recycle. Instead of demolishing the building, you can adapt it to change. The challenge is to do buildings which encourage change, which respond to change and to have technologies and techniques which enable buildings to improve their performance."(Marianne 2022) This raises the question of how we can design architecture that can stand the change of time in the first place. What factor could change in the future that architects and designers should be aware of? What different approaches should architects and designers take? Moreover, what challenges face adaptive architecture?

### **Factors to which Architecture Needs to Adapt**

Architecture reflects how humans live. Buildings are designed for human demands, but their demands shift based on changes in society. Therefore, designers and architects should know the factors driving social change that could influence architectural design. Change happens in human society through time and occurs at all levels. Many factors drive these changes. The following are some significant factors that drive change in society (Little 2016, 4).

#### **Natural Factors**

One of the leading causes of social change is geographic shift. Both the physical and natural forces contribute to society's formation and dissolution. Storms, floods, droughts

and other natural occurrences can cause social havoc. Several physical or environmental conditions can seriously disrupt social life. For example, climate change is forcing our society to change our actions, such as reducing our reliance on fossil fuels, which has led to a decline in gas stations.

### **Demographic Factors**

Demographic factors involve changes in the size and makeup of the population. Population changes have a significant impact on people's economic well-being, which may impact on other facets of their lives. Problems with unemployment, starvation, poverty and housing are brought on by population growth. So, it is crucial to maintain a country's natural resource and population balance.

### **Cultural Factors**

Social transformation can also result from new cultural values and belief systems. Although nonmaterialistic components of society (e.g., culture) move extremely slowly, changes in the materialistic aspects of society, like new technology, are quickly absorbed. The media distributes and diffuses information to a big audience, causing diffusion. It has sped up the process of change by disseminating aspects of other cultures to individuals who live far away, leading to cultural modernization.

### **Political Factors**

Political issues, including elections, laws and public opinion, also greatly influence social transformation. Laws are a tool for bringing about political and socioeconomic change in society. However, laws, on their own, cannot alter a particular culture's deeply ingrained customs and belief systems. For

legislation to be successful, public opinion must also be mobilized.

### **Economic Factors**

Economic variables also affect the pace and scope of social change. Both the Industrial Revolution and Green Revolution significantly impacted civilization. According to Karl Marx, the bourgeois-proletariat class conflict is what ultimately leads to social change. Marx believed that a workers' revolution against the capitalists would put an end to the negative effects of capitalism and result in the foundation of a socialist society.

### **Architecture Is Not a Static but a Participant**

People may think architecture never changes because they associate it with historical monuments that have remained mostly unchanged for centuries, like the Parthenon in Greece or the pyramids in Egypt. However, architecture is more than the physical residual from the past.

Like all other human creations, architecture is not a static object that exists outside of the passage of time but an active participant in the change of time. Architecture constantly changes with time, reflecting the shifts and developments of society, culture and technology (Brand 1995, 22).

Throughout history, architecture has evolved to meet the changing needs of people, from ancient times to the present day. Japanese sociologist Munesuke Mita states in *Project Japan: Metabolism Talk*, "The idea of keeping architecture permanently is hypocritical, whereas considering architecture as temporary is authentic. Perhaps our desire to imprint the ground with something imperishable is a manifestation of gross civilization" (Koolhaas 2011, 377).

One of the most notable ways architecture changes with time is through its style. Different architectural styles have emerged throughout history, each reflecting the values and culture of a particular time period. For example, Gothic architecture, popular in the Middle Ages, reflects that period's religious and cultural values with intricate stone carvings and pointed arches. In contrast, architecture of the twentieth century, characterized by its simplicity, minimalism and the use of new technologies such as steel and glass, reflects the period's technological advancements and rise of industrialization (Brand 1995,123).

Another way architecture changes with time is through its function. Structures are designed to meet specific needs and serve specific functions. As society and culture evolve, the demands placed on buildings also evolve. For example, the need for housing and working spaces has led to the development of various building types like skyscrapers, apartment buildings and office buildings. The rise of technology, the internet and remote work have changed

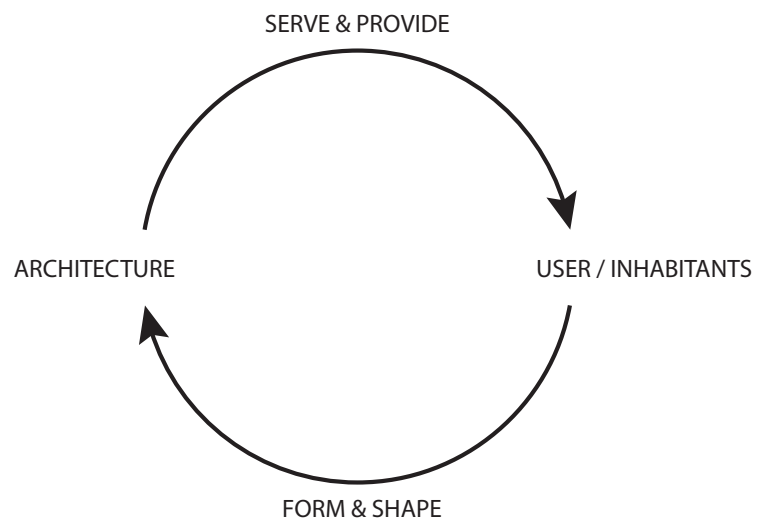

Illustration of the relationship between architecture and user/ inhabitants

the way we live and work, leading to the development of flexible, open-plan spaces and coworking spaces. This phenomenon can be best seen in the past two years, during the COVID-19 pandemic. When the world shut down, most people had to switch how they lived, worked and studied.

Relationship between architecture and user shown

In addition, architecture changes with time in terms of its impact on the environment. In the past, buildings were primarily designed for function and aesthetics, with little consideration for their environmental impact. However, as society becomes more environmentally conscious, the importance of sustainability and energy efficiency in buildings is increasing (Smith 2006, 6). This has led to the development of new building materials, new technologies, energy-efficient construction methods and the incorporation of green spaces and sustainable design principles (Brand 1995, 427).

Finally, architecture changes with time by reflecting and shaping culture and society. Architecture can shape society by creating spaces promoting certain behaviours and values. It can also reflect the values and culture of a society by embodying its aesthetics, customs and beliefs. In recent history, we have seen architects use their work to express their opinions or as a vessel to make people rethink their relationship with the environment .

Although people often compare an architectural piece to a sculpture, architecture is not equal to art. Architecture reflects the functional demand of society. Brand says:

Art must be inherently radical, but buildings are inherently conservative. Art must experiment to do its job. Most experiments fail. Art costs extra. How much extra are you willing to pay to live in a failed experiment? Art flouts convention. Convention became conventional because it works. Aspiring

to art means aspiring to a building that almost certainly cannot work because the old good solutions are thrown away. The roof has a dramatic new look, and it leaks dramatically. (Brand 1995,127)

Architecture is clearly not a static object that exists outside of the passage of time but an active participant in it . Architecture should reflect the shifts and developments of society, culture and technology. From the style to the function and environmental impact, architecture is constantly in motion, reflecting the current time and shaping the future. One of the most notable ways architecture participates in the change of time is through its adaptability. It can adapt to changing demands, shape and reflect society and contribute to the preservation of the environment. In other words, architecture is not fixed because it cannot be fixed. A fixed architecture will most likely not stand the test of time because everything around it is constantly changing.

### **Why Is It a Challenge for Architecture to Adapt?**

As a result of our ever-changing society, the buildings we construct are also influenced by different factors. Brand (1995, 22) outlined the three primary forces that push our buildings to change: technological factors, money, and fashion.

#### **Technological Factors**

One of the most significant forces that push building change is technological innovation. We might think of technological innovation as life-changing events, but technological innovation can also subtly influence our buildings. For example, the creation of nails changed how we assemble buildings. Nails provide builders with a quick and easy way to put lumber together, and from there, various building techniques were born and design guideline lines were

created. Moreover, technological development in machinery and manufacturing allows builders to explore different building materials and construction methods (Brand 1995, 22).

## **Money**

Few buildings can exist without funding; thus, money is another force that drives the change in buildings. It drives not what we are building but how we are building. The market influences the building, and people attempt to build buildings as economically efficiently as possible. Brand (1995) says:

Form follows funding. If people have money to spare, they will mess with their building, at minimum, to solve the current frustrations with the place, at maximum, to show off their wealth, on the reasonable theory that money attracts money. A building is not primarily a building; it is primarily property, and as such, subject to the whims of the market. (Brand 1995 22)

## **Fashion**

Fashion is the projection of our life. With society constantly changing, our perspective on the world changes; therefore, what we want to project outward changes as well.

As for fashion, it is changing for its own sake—a constant unbalancing of the status quo, cruellest perhaps to buildings, which would prefer to remain just as heavy and obdurate, a holdout against the times. Buildings are treated by fashion as big, difficult clothing, always lagging embarrassingly behind the mode of the day. This issue has nothing to do with function: fashion is described precisely as “non-functional stylistic dynamism” in *Man’s Rage for Chaos* by Morse Peckham and fashion is culture-wide and inescapable. (Brand 1995, 23)



## Chapter 3: Method: Theories and Data Analysis

### Research: Theories and Case Studies

Designing architecture that can actively adapt to time is nothing new. Many theories and critical figures have given their answer to the question. From cybernetic architect Cedric Price to Japanese metabolism architects, all have realized the importance of architecture's ability to adapt, but each of them has their response to the same question.

### Quick Summary

#### *Cybernetic*

Cybernetic architecture emerged in the mid-twentieth century, and it sought to apply cybernetic principles to the design of buildings and urban spaces. In the traditional architectural design approach, the building is an unchanging object, merely a place for human habitation. However, a group of scientists, engineers and architects who identify as cyberneticists have researched living machines and living architecture (Fredrik 2017, 55). They concentrate primarily on system science and let the machines manage themselves, similar to a creature's brain.

Cybernetics can be applied to mechanical, physical, biological, cognitive and social systems, among others. Cybernetics can be applied when a system needs to be analyzed in a closed loop (Menges and Ahlquist 2011, 10) because when a system causes a change in its environment, the system reflects the change in some form of feedback, which then causes the system to change. Cyberneticists

have studied concepts such as connectivity, social control, communication and cognition.

Over the past hundred years, architects have been interested in the management system of control, communication and development (Herdt 2021, 45). According to Gordon Pask, “It constantly interacts with its inhabitants, serving them on the one hand and dictating their behaviour on the other. In other words, the architect is primarily concerned with these larger systems, which make sense as components of larger systems that include human components” (Menges and Ahlquist 2011, 68).

The use of cybernetics in architecture has made it possible for architecture to respond to user and environmental input and change as necessary to meet user needs. Michael Mozer, a contemporary cyberneticist, says that in the most recent instance, a house’s “intelligence” consists of anticipating human behaviour and providing feedback.

### ***Structuralism***

Around the middle of the twentieth century, the structuralist movement in architecture and urban planning began to take shape. It was a response to Congrès Internationaux d’Architecture Moderne, founded in 1928 by Le Corbusier and other Europeans, which triumphed functionalism (rationalism), which had produced a lifeless urban planning expression that disregarded the inhabitants’ identities and urban forms. In a broad sense, structuralism is a school of thought that emerged in various contexts and fields such as linguistics, anthropology, philosophy and art.

As described by philosopher Simon Blackburn, “Structuralism is the belief that phenomena of human life

are not intelligible except through their interrelations. These relations constitute a structure, and behind local variations in the surface phenomena, there are constant laws of abstract culture” (Greene 2020). The idea of structuralism is that the world can be understood in terms of structures. Influenced by the structural linguistics of Ferdinand de Saussure, French anthropologist Claude Lévi-Strauss explores the universals of human culture and states that human life can be understood only through relationships and the relationships that make up a structure behind local variations. They further argued that certain cultural domains could be understood only through structures (Greene 2020). This theory, which had its roots in linguistics, was later applied to a wide range of disciplines, including architecture, where it became popular in the 1960th regarding issues of technical reasoning. Since the introduction of structuralism, architecture has ceased to be a democracy where people can change their buildings because its primary goal is the expression of social relations and sociocultural patterns .

Architecture’s structuralist movement is a response to rationalism, which structuralists see as a lifeless form of urban planning. When designing buildings, structuralist architects prioritize cultural aspects. Buildings are arranged by architects and city planners based on streets, squares and communication routes, making the city structure both complex and invariant.

### ***Metabolism***

New concepts for urban planning and public spaces have emerged as a result of the postwar reconstruction of Japan’s cities (Cho and Shin 2014, 623). A “metabolism” concerns the procedure of maintaining living cells. After World War

II, young Japanese architects used this term to describe how cities and buildings should be planned to mimic living things (Schmidt and Eguchi 2014, 75). The idea behind the metabolic architecture and design is that cities and structures are not static objects but rather dynamic organisms with a metabolism.

Structures built after World War II to accommodate population growth were considered to have a limited lifespan and were planned and constructed to be replaced. The metabolism movement stepped in to fill the void left by the disbandment of the CIAM. A group of young Japanese architects challenged the outdated European notions of static urbanism at the Tokyo World Design Conference in 1960. *Metabolism 1960: Proposals for a New Urbanism* documented the ideas and philosophies of Fumihiko Maki, Masato Otaka, Kiyonari Kikutake and Kurokawa. Many Metabolists studied under Kenzo Tange at Tokyo University's Tange Laboratory (Schmidt and Eguchi 2014, 75).

### ***Open Building & Shearing Layers***

In the Netherlands, the term "open building" (Open Bouwen in Dutch) was first used in the mid-1980th, about twenty years after John Habraken first proposed the support/infill concept for housing (*Supports: An Alternative to Mass Housing*, 1961) and after the publication in 1965 of design methodologies for housing based on that concept, developed at the Dutch Stichting Architecten Research or Foundation for Architects Research (Nascimento 2012, 7).

The open building theory is a design philosophy that advocates for creating buildings that can adapt to changing needs and conditions over time. It proposes that buildings should be designed and constructed with a flexible,

modular framework, allowing for easy modification and reconfiguration. The theory emphasizes the importance of separating a building's core structure from its internal systems and finishes. The core structure, consisting of the foundation, load-bearing walls, and roof, is designed to remain intact for the building's lifespan. In contrast, the internal systems and finishes, such as plumbing, electrical, and wall partitions, can be easily modified or replaced without affecting the building's core structure.

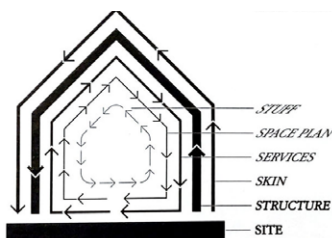

Shearing layers diagram  
(Brand 1994, 38)

According to the Shearing Layers theory, The Site layer is the most permanent layer, including the building's foundation and site infrastructure. The Structure layer is relatively permanent and includes load-bearing walls, columns, and beams. The Skin layer includes the building's external cladding and windows, which are replaced less frequently than the internal finishes. Finally, the Services layer includes the internal systems of the building, such as heating, cooling, lighting, and plumbing, which have the most frequent updates.

In Europe, several innovative projects had already been built with success. Open building theory and practice had gained international attention by this point, and developments in this direction were also occurring in Japan. The Open Building group at the Technical University of Delft began conducting research in the mid-'80s to examine the practical steps required to fully implement the support/infill approach, concentrating on technical, regulatory, and financial issues.

## Case Studies

### *Orphanage in Amsterdam*

The Aldo van Eyck Orphanage in Amsterdam is a well-

known example of modernist architecture designed by Dutch architect Aldo van Eyck in the 1950s. The building was created to serve as a home for children who had been orphaned during World War II. The main idea behind the Aldo van Eyck Orphanage is to create a building that would be more than just a functional space for living and sleeping. Van Eyck holds that a building should be a place of community and interaction where the children could learn, play and grow. To achieve this goal, van Eyck designed the building as a series of interconnected courtyards and pathways. He designed the courtyards to be flexible spaces that could be used for various activities, from playing games to holding outdoor classes, and pathways to encourage movement and exploration, allowing the children to move freely throughout the building and discover new spaces and experiences.

The building's interior spaces were also designed for children's needs. Van Eyck says that every child should have a sense of belonging and ownership over their living

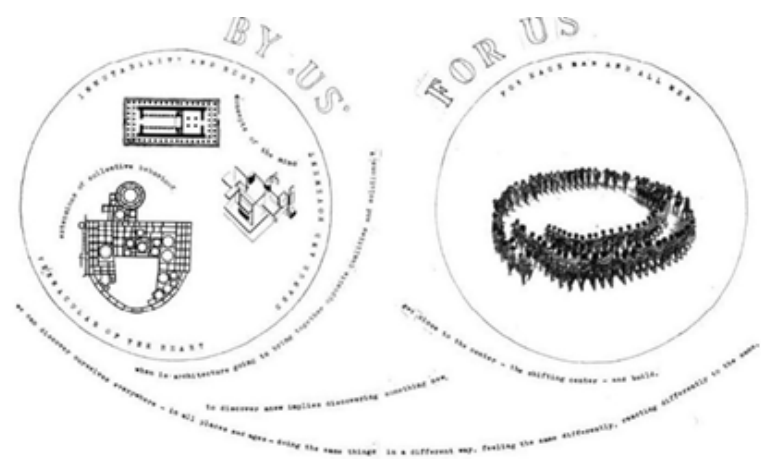

Aldo van Eyck, concept diagram of Children's Home, Amsterdam, 1955 - 60 (Fracalossi 2019)

space, so he designed each room to be slightly different, with unique features and details. He also incorporated playful elements throughout the building, such as brightly coloured walls and playful patterns, to create a cheerful and welcoming atmosphere.

The Aldo van Eyck Orphanage was designed with a strong emphasis on flexibility and adaptability. Van Eyck recognized that the needs of the children living in the orphanage would change over time, and he wanted to create a building that could evolve with them. One of the key ways the building was designed to adapt to change was through its use of modular, interconnected spaces. The building comprised a series of smaller rooms, courtyards and pathways that could be combined and reconfigured in different ways to accommodate changing needs and uses. This allowed the children to have a sense of ownership and control over their living spaces while also giving them the freedom to adapt the spaces to their changing needs.

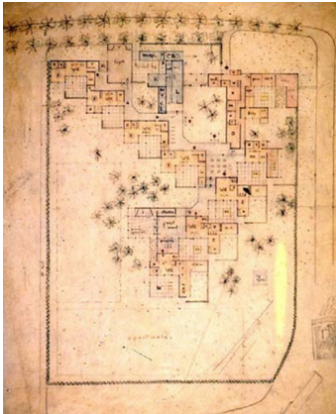

Orphanage plan sketch by Aldo van Eyck, Amsterdam, 1955 - 60 (Fracalossi 2019)

In addition to its modular design, the Aldo van Eyck Orphanage was designed to be adaptable in terms of its use of materials and finishes. The building's materials were carefully chosen to be durable and long-lasting but also easy to replace and repair as needed. This allowed the building to remain functional and beautiful over time, even as the needs of its occupants changed.

The Aldo van Eyck Orphanage was designed to be a living, breathing space that could adapt and evolve with its inhabitants. Van Eyck's approach was based on the belief that architecture should be responsive to the needs and desires of its users and that by designing flexible, adaptable and inclusive spaces, we can create environments that

foster creativity, connection and well-being over the long term.

### ***Potteries Thinkbelt Project***

The Potteries Thinkbelt project was a visionary educational proposal designed by the British architect and designer Price in the late 1960s. The project proposed creating a new kind of educational system that would revolutionize how people learn, using technology and mobility to create a more flexible, personalized system that is responsive to individual needs (Aureli 2011, 99).

At the core of the Thinkbelt project was a network of mobile units that would travel around the country, providing educational resources and opportunities to people wherever they were. These units would be equipped with state-of-the-art technology, including computers, televisions and other multimedia tools, allowing people to access various information and resources anywhere.

The Thinkbelt would also incorporate a variety of physical spaces, including traditional classrooms and lecture halls as well as more unconventional environments, such as mobile laboratories and outdoor learning areas. The project was aimed to create a more dynamic and adaptable system than traditional educational models, allowing students to learn in various ways and settings.

One of the most radical aspects of the Thinkbelt project was its focus on individualization and personalization. Rather than imposing a one-size-fits-all approach to education, the Thinkbelt would allow students to design their own learning paths and adapt their education to their interests, needs and abilities. This would be supported by advanced data analysis



tools, which would track each student’s progress and provide feedback and recommendations to help them optimize their learning experience (Herdt 2021, 54). The Thinkbelt project was designed to be adaptable and responsive to changes, both in terms of individual learners’ needs and the broader educational landscape.

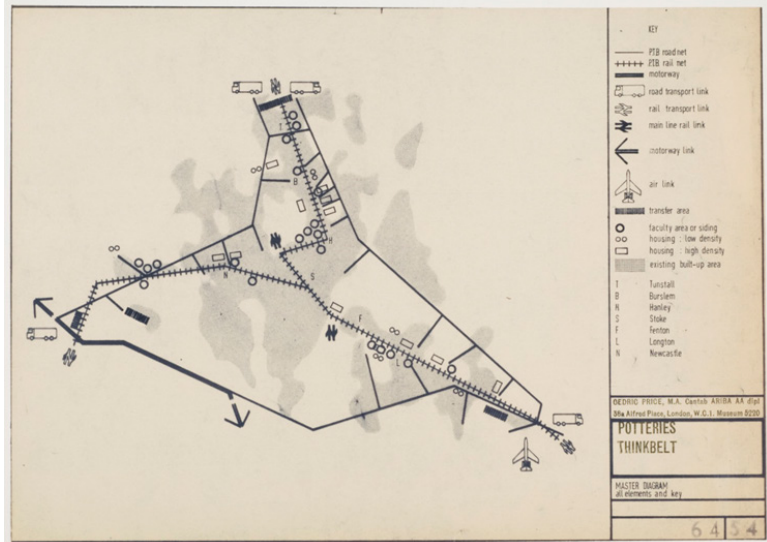

Cedric Price, master plan of Potteries Thinkbelt Project, Staffordshire, 1964 (“Hidden Architecture” 2021)

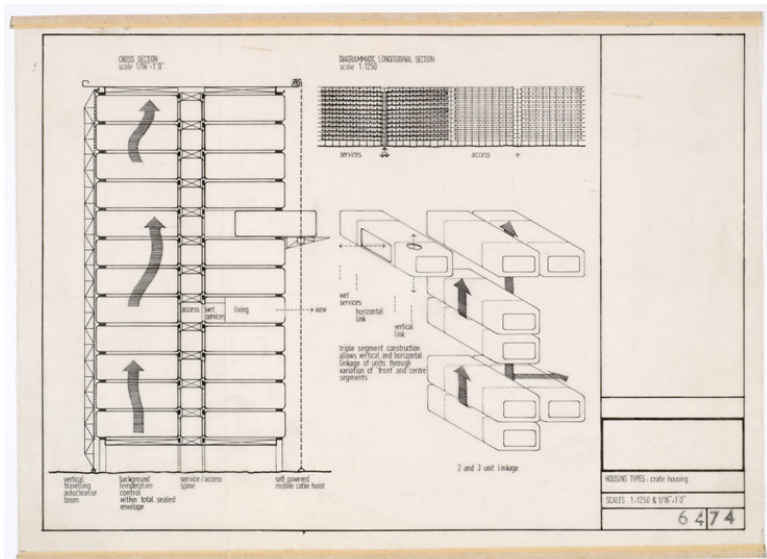

Cedric Price, drawing of Potteries Thinkbelt Project’s residence, Staffordshire, 1964 (“Hidden Architecture” 2021)

Overall, the Thinkbelt project was designed to be a highly adaptable and responsive educational system, capable of evolving and changing over time to meet the needs of individual learners and the broader educational landscape. Although the Thinkbelt project was never fully realized, it remains a fascinating and influential vision of what education space could be. Its emphasis on mobility, technology and personalization has inspired many other innovative educational projects in the decades since its inception, and its legacy continues to shape the way we think about learning and education today.

### ***The Inter-Action Centre***

Price first proposed the Inter-Action Centre in the early 1970s as a response to the social and cultural changes that were taking place in Britain at the time. Price recognized that traditional community centres and social spaces were often rigid and inflexible and failed to meet the diverse and dynamic needs of modern communities Price sees the built environment as a system of human interaction (Herdt 2021, 55).

Price proposed a radical new approach to community centre design to address these challenges. Instead of creating a fixed, permanent structure, he designed a system of modular units that could be assembled and reconfigured in various ways. This allowed the centre to adapt to changing needs and uses over time and accommodate a wide range of activities and events shown in photograph below.

In addition to its modular design, the Inter-Action Centre was intended to be a socially inclusive space. Price recognized that many traditional community centres were exclusive or unwelcoming to specific groups of people, and he wanted to



Cedric Price, Inter-Action Centre during construction, London, 1972 ("Hidden Architecture" 2017)

create a space that was open and accessible to everyone. To achieve this, he designed the centre to be highly flexible and responsive to the needs and interests of the local community.



Cedric Price, Inter-Action Centre, London, 1972 ("Hidden Architecture" 2017)

The Inter-Action Centre was also designed to be highly interactive, focusing on encouraging social engagement and cultural exchange. Price envisioned the centre as a place where people could come together to share ideas, participate in cultural activities and build community. This was reflected in the centre's programming, which was designed to be responsive to the needs and interests of the local community. Although the project was never fully realized, its legacy has inspired many other innovative community projects over the years, and it continues to be recognized as a visionary example of socially engaged.

### ***The Centraal Beheer***

The Centraal Beheer building in Apeldoorn was designed by Herman Hertzberger as a pioneering example of adaptive architecture. Hertzberger believed buildings should be designed as dynamic, responsive spaces that can adapt and evolve to meet their users' changing needs and desires

One of the key ways the Centraal Beheer building was designed to be adaptive was through its use of flexible, customizable workspaces. The building's open floor plans, modular furniture and movable partitions allow employees to quickly reconfigure their workspaces to suit their changing needs and work styles. This made the building a more adaptable and responsive workplace able to evolve with the organization's changing needs. The Centraal Beheer building was also designed to be adaptive using natural light and ventilation. The building's large windows and open-air courtyards allow for ample sunlight and fresh air, creating a comfortable and healthy working environment for employees. This emphasis on natural light and ventilation

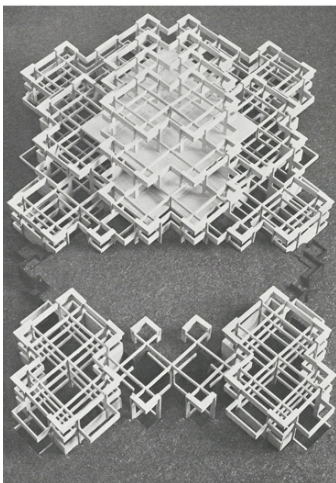

Structural model of the proposal, 1962; presented by Joop van Stigt (Stigt 1963, 17).

also allow the building to be more energy-efficient and sustainable over the long term.

Moreover, Hertzberger designed the Centraal Beheer building as a series of interconnected spaces with communal areas for socializing, collaboration and relaxation. This helped create vibrant and inclusive workplaces where employees can connect and collaborate with one another in a variety of settings. The building's flexible design and communal spaces also make it a more adaptable and responsive environment, accommodating changing work patterns and organizational needs.

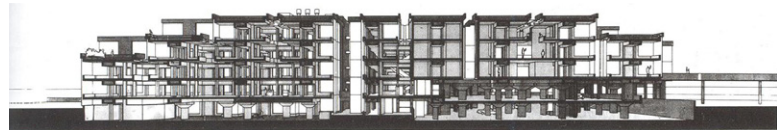

Herman Hertzberger, section of the Centraal Beheer building, Apeldoorn, 1972 (Hertzberger 2016, 4)

### ***The Capsule Tower***

The Capsule Tower was designed by Japanese architect Kurokawa in 1972. It is located in the busy and densely populated district of Ginza in Tokyo, Japan. The tower comprises two connected concrete towers, one eleven stories high and the other thirteen stories high. The tower was designed to house 140 capsule apartments, each just 2.5 metres by four metres.

The Capsule Tower embodies many of the principles of metabolism, including its modular design, adaptability and emphasis on communal living. The building was designed to be a flexible and responsive living space, with individual capsules that could be easily added, removed or modified. This modular design allowed the building to adapt to changing social, economic and environmental conditions

over time, in keeping with the principles of metabolism . The Capsule Tower also emphasizes communal living, with shared spaces encouraging residents' interaction and socialization. This communal living approach reflects the metabolism movement's emphasis on creating buildings and cities that foster community and connection.

Additionally, the Capsule Tower is an example of adaptive architecture because it was designed to respond to its urban context's specific needs and constraints. For example, the building's modular design allowed it to be constructed quickly and efficiently in a densely populated urban area. Its small living spaces were designed to provide affordable and convenient housing for Tokyo's growing population, and its communal spaces and rooftop garden provided opportunities for socializing and recreation in an otherwise dense and busy urban environment.

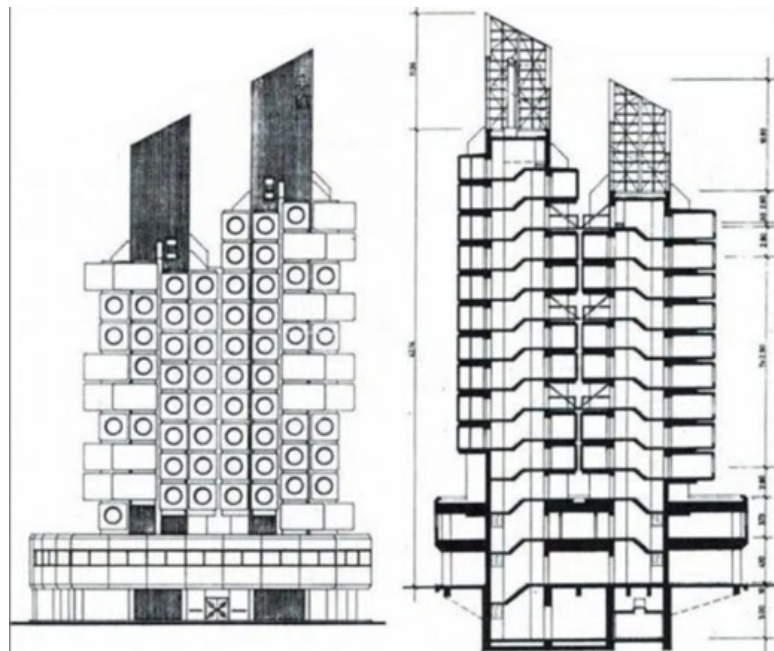

Kisho Kurokawa , elevation and section of Nakagin Capsule Tower, Tokyo, 1972 (“DOMUS“ 2022)

The Capsule Tower is also a pioneering example of metabolism and adaptive architecture, embodying the movement's principles of modularity, adaptability and communal living while responding to the specific needs and constraints of its urban context. Despite its innovative design and association with the metabolism movement, the Capsule Tower has faced several challenges. The building's maintenance has been an ongoing issue, and many of the original residents have moved out because of concerns about the building's structural safety.

### ***The Sky House***

The Sky House was designed and built by Japanese architect Kiyonori Kikutake as his private residence. Its design was intended to be adaptable and flexible, allowing for changes and modifications over time. As a prime example of the metabolism movement in architecture, the building was designed to adapt and grow in response to changing needs and conditions.

One of the most significant ways the Sky House was designed to change over time is through the addition of new living spaces or modules. The building's steel and concrete framework was designed to support additional cantilevered living spaces, which could be added as needed. The Sky House's open-plan living spaces and emphasis on natural

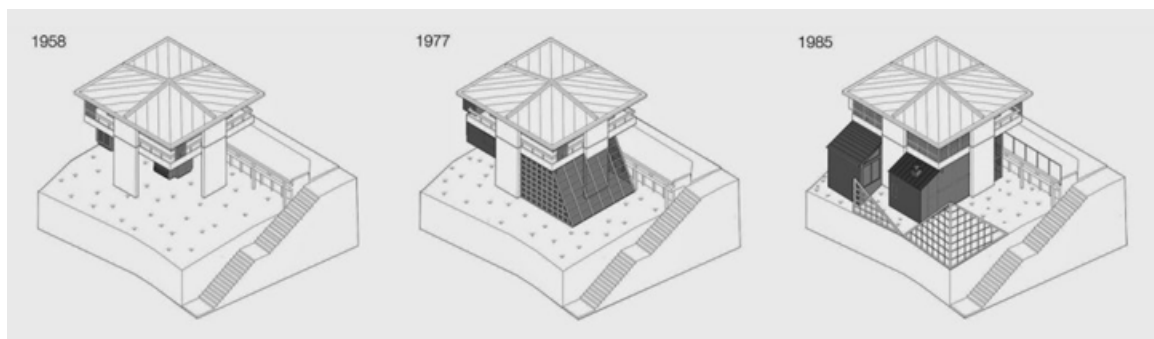

Kiyonori Kikutake, transformation process of the Sky House, Tokyo, 1958 (Bann 2020)

light and views were designed to be adaptable to changing lifestyles and preferences. The interior spaces can be reconfigured or modified to suit the occupants' needs. Transition over the years.

However, it is important to note that the ability of the Sky House to adapt and change over time depends on proper maintenance and upkeep of the building's structural integrity. Like any building, the Sky House requires regular maintenance and repairs to remain safe and functional.

### **Theories Review and Reflection**

This thesis has looked into structuralism and cybernetic architects such as van Eyck, Hertzberger and Price. Both structuralism theories and cybernetics have repeatedly hinted that our future is unknown. Therefore, it is essential for architecture to be designed over time and to stand the test of time (Price and Obrist 2003, 59).

Similar to structuralism, Price also brought the concept of design in time approaches. The conventional lump sum approach is a project-based method where a building is designed and completed in a concentrated period. Alternatively, structuralism and Price suggest that architectural design should perhaps be a process-based approach, shown in diagram below, where the architecture is materialized in a time-phased manner, allowing the design of architecture to be open-ended (Williams 2018). Thus, the architecture can be redesigned or redeveloped to meet the new social demand later. This design-in-time idea is evidenced in Price's drawing.

Although the idea of "designing in time" to adapt to the potential changes inspired this thesis on how it would



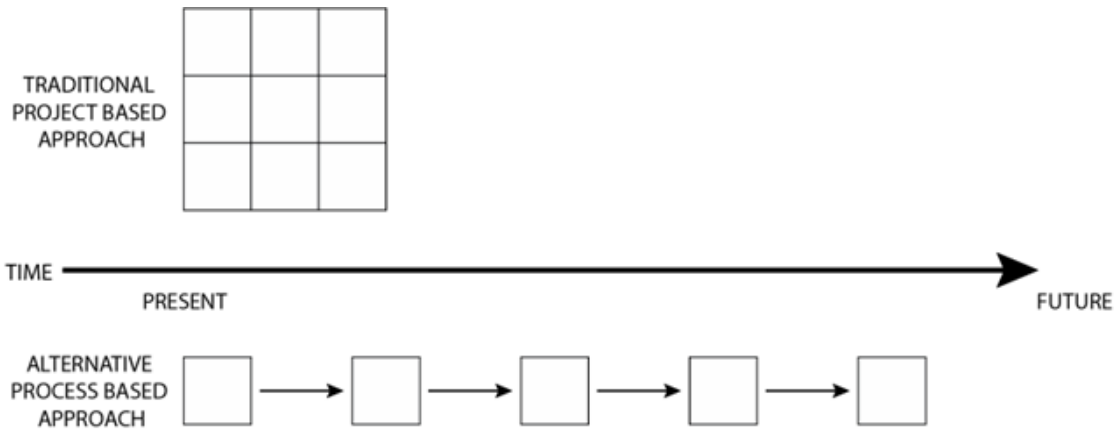

Project-based approach vs. Process-based approach

like to approach the final project, when one examines the architecture pieces by structuralism and cybernetics architects, most of the buildings have not successfully undergone the transformation process as the architects implied. There could be many reasons, such as the economic

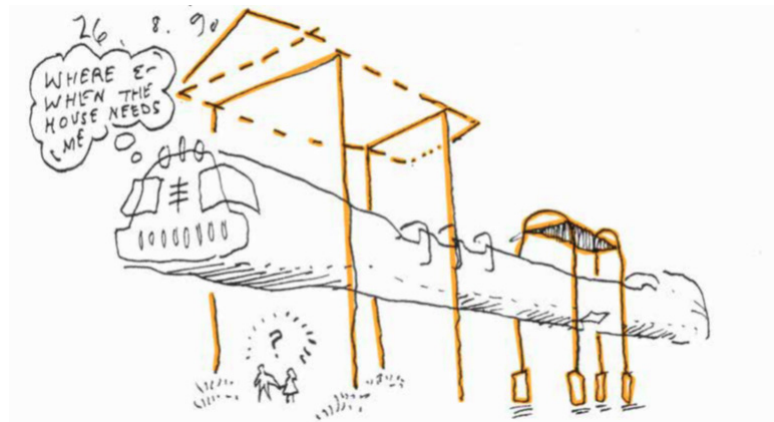

The Dynamics of Time sketch by Cedric Price, London, 1972 ("Archis" 2015)

factor or construction logistics, or there was no need for them to change. Overall, Structuralism aimed to answer the question through repetitive patterns/gird evidenced by the plan from Herman Hertzberger. However, although the pattern provides a underlying structure for architecture to develop further, it is also restricted since future development

needs to follow the previous patterns and grids, shown in the drawings below.

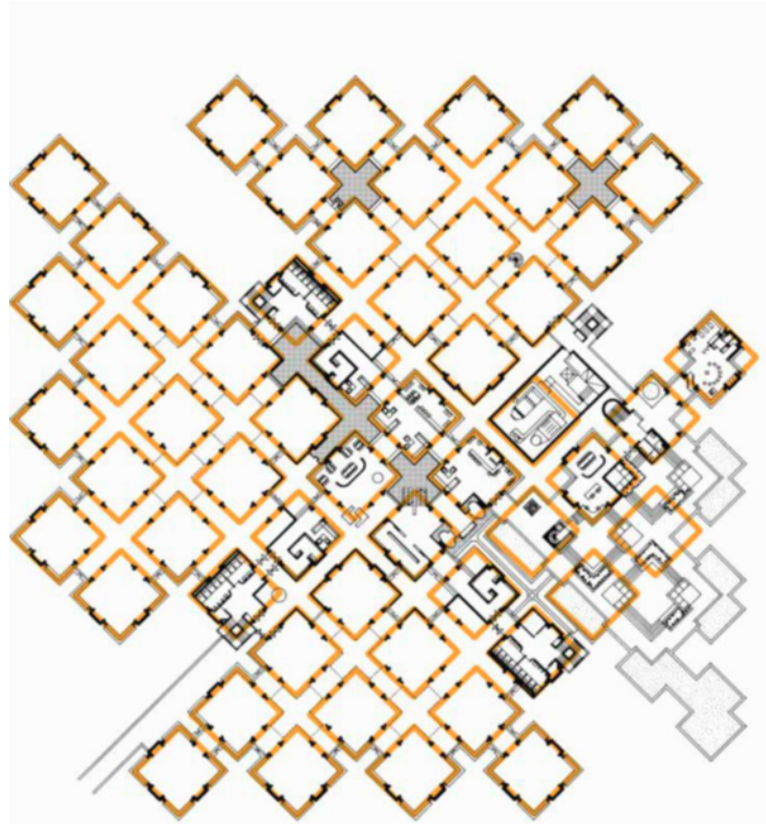

Plan analysis of the Centraal Beheer building, Apeldoorn, 1972  
(base drawing from Hertzberger 2016, 4)

Metabolism approaches adaptive architecture design through modular design and prefabricated units, which is best shown in the Capsule Tower and Takara Group Pavilion. As 2022 is the final year of the Capsule Tower, it also exposed the weaknesses and challenges in metabolism's modular and prefabricated design approach, especially from the building envelope and electrical and plumbing aspects (McCurry 2023). Metabolism's idea of interchangeable units solved architecture's scaling issue, but the moveable quality of the unit creates the challenge of not having a continuous building envelope to protect the building from

weather elements. The physical connection between each unit and the main structure is the weakness of the building's envelope, where leakage could occur. Moreover, the more units attached to the main structure, the more potential weak points are created.

However, one architectural piece underwent a transformation process over a long period and still stands today: Kikutake's

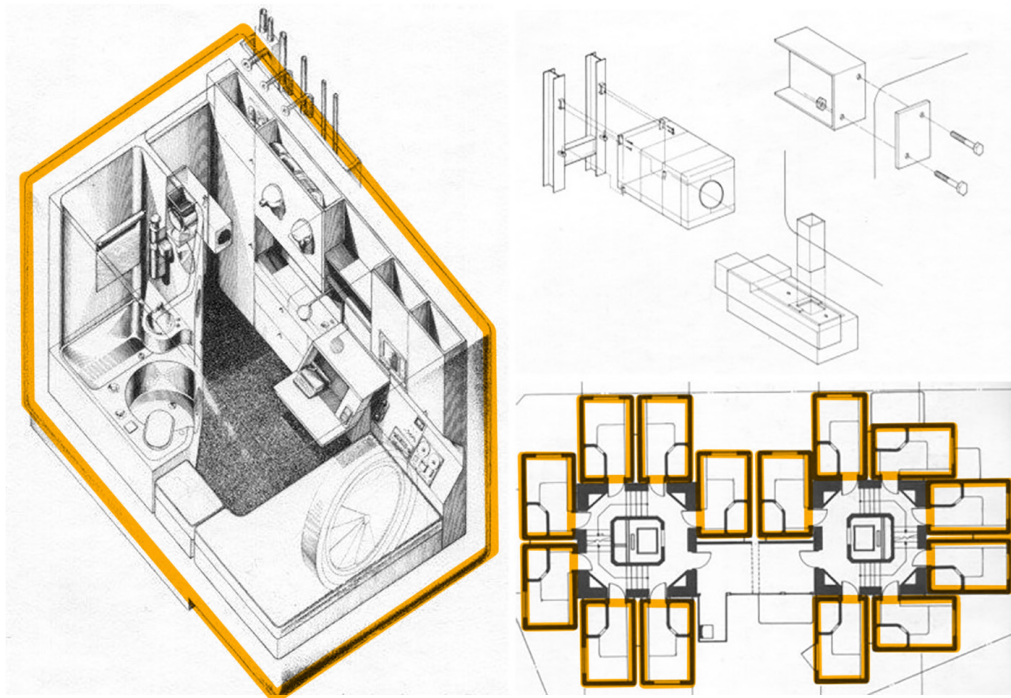

Kisho Kurokawa , technical drawing of Nakagin Capsule Tower, Tokyo, 1972 (base drawing from "DOMUS" 2022)

private residence, the Sky House. Since its completion in 1958, the house has undergone several rounds of alteration. Interestingly, this adaptive process is not through the conventional metabolism's prefabrication unit approach but rather through a prefabricated building systems or layers approach. For example, the main structure of the Sky House does not participate in the transformation. Kikutake uses prefabricated building elements to rearrange and construct

alternative spaces on the existing site and within the existing structure. Figure 22 compares each plan. The plumbing fixtures, furniture and internal partitions are the elements that were rearranged. Finally, after structuralism, Price and Japanese metabolism, I present the open building theory and “shear layers” approach, which sees the building as



Plan study of the Sky House, designed by Kiyonori Kikutake, Tokyo, 1958 (base drawing from Bann 2020)

different layers with various life spans. Habraken and Brand are two prominent figures in the study of open building/shearing layers. Brand's work examines the different building layers from a scientific perspective, such as the lifespan of various building materials that make up the building layers. The open building/shear layering theory gives the thesis

the framework to analyze the project site and its existing structure, such as the leftover canopy and storefront (Figure 23). However, this has a backward-looking view. As Brand's title (*How Buildings Learn*) suggests, Brand dissects the existing buildings into layers and learns from them.

As a complete building, the six-building layers make sense. However, architecture is not entirely the same as a physical

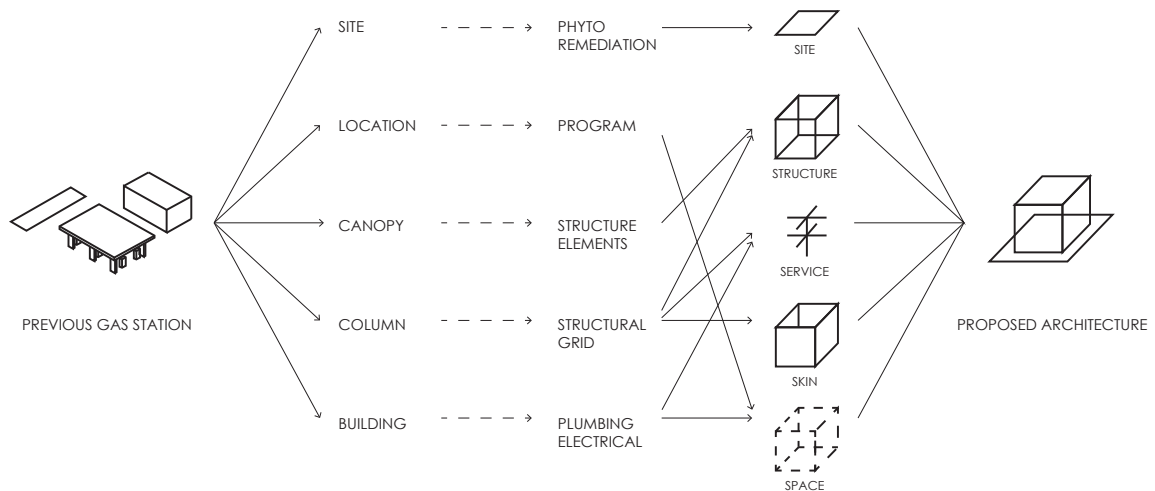

Analysis of existing gas station using the open building and shearing layers theory

building. Regarding architecture sense and space-making, one would argue that not all six layers, such as a pavilion, must be present simultaneously in the beginning. Although the lack of particular layers, such as skin and service, would dramatically affect how a building is used, not having all six layers would not stop occupants from experiencing architecture but experimenting differently.

Therefore, we can see that these theories all resonate with this thesis's context. However, each of those theories provides its response to some aspects of adaptive architecture but not all. For instance, structuralism and cybernetics offer a guideline on a theoretical level; metabolism answers how

architecture could be scalable, and open-building and shearing layers theory examine adaptive ability from a buildings science perspective. Resulting in an attempt to combine the design-in-time approach with the concept of open-building and shearing layer theory. In other words, in this thesis I apply the design of the different building layers in the time-phased process based on their potential lifespan and their relationship with other layers and how each layer would affect the occupants' experiences and interactions with the architecture itself.

As following diagram show, I am taking the open building/ shearing layers concept, unfolding the famous diagram by Brand, and applying the design-in-time approach to the different layers. For example, the architecture piece could first be a structure that provides people shelter from the weather. Then some closure is added to allow some

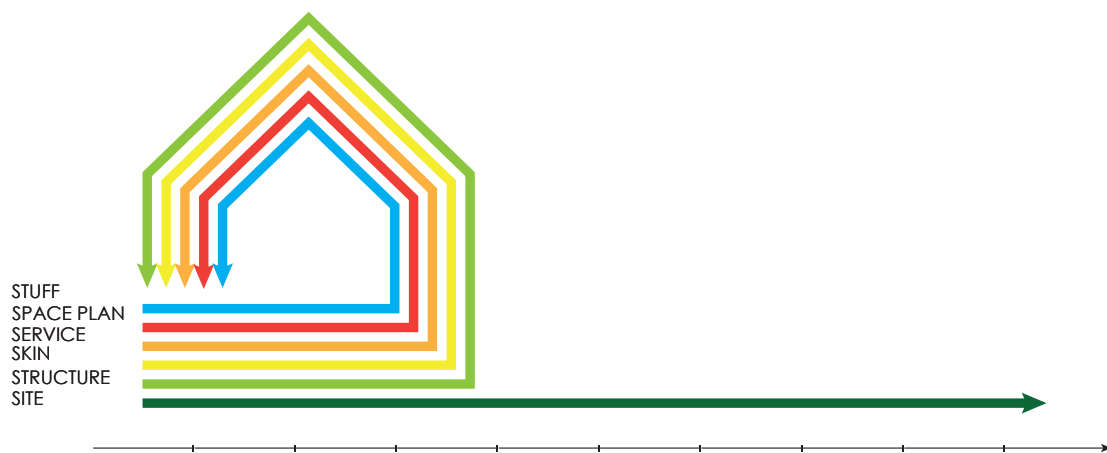

Taking inspiration from the shearing layers diagram (base diagram from Brand 1995, 38)



Unfolding the six layers of shearing layers diagram (base diagram from Brand 1995, 38)

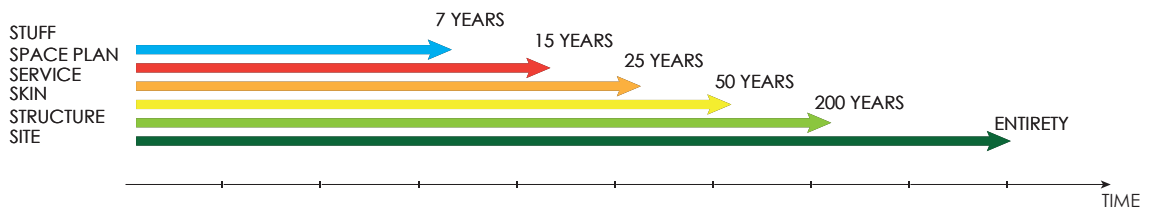

Examining the six layers of shearing layers diagram (base diagram from Brand 1995, 38)

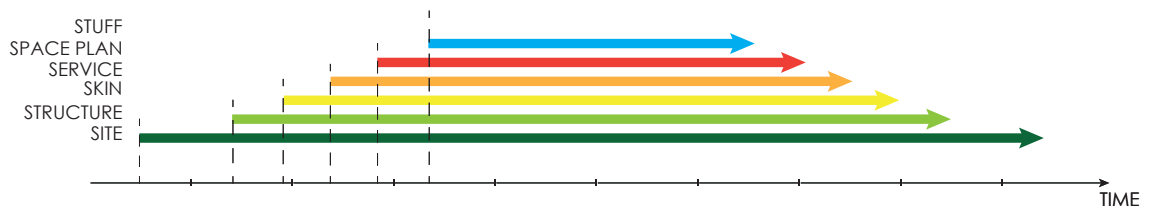

Applying a design-in-time approach to building layers, and building each layer in different phases (base diagram from Brand 1995, 38)

## Data Collection and Analysis

Echoing the early writings, we cannot know what will happen, but one can still be prepared by knowing where and how the change will occur. According to sociology studies, six significant factors drive societal changes: natural, technological, demographic, cultural, political and economic factors. So, to prepare for the future, I will analyze and respond to the data that best reflect social changes. They concern gas station locations; people's moving trends; population, including the youth and the seniors; household size; household income; and lifestyle.

## Data Collection Framework

Illustration below shows the factors that drive social change and the data that reflect them.

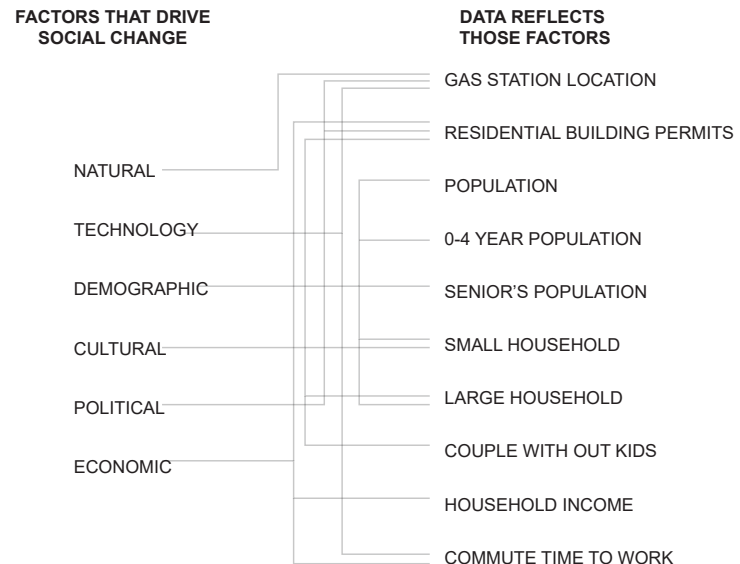

Factors that drive social change and data reflects those factor



## Data Mapping and Visualization

The raw data used in this thesis are from the Canadian Census database. I use mapping and graphing techniques to visualize the raw data so they can be better understood and processed.

### *Gas Station Locations in Vancouver*

The following maps indicate the locations of gas stations in Vancouver with orange dots and the walkable area with yellow shapes.

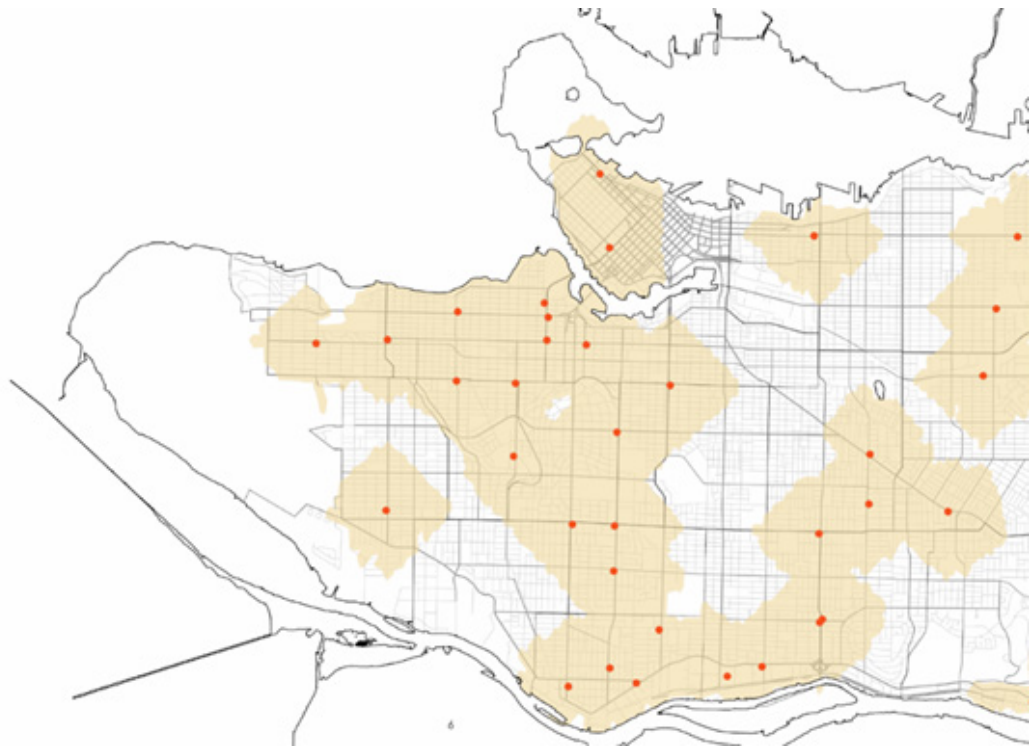

Map of Vancouver's gas location and area within walking distance from gas stations (Data from CAPP 2020).

### ***Residential Building Permits***

The following map indicates the hot spots of which part of the city experiences population inflow. The Rest of the Social Data.

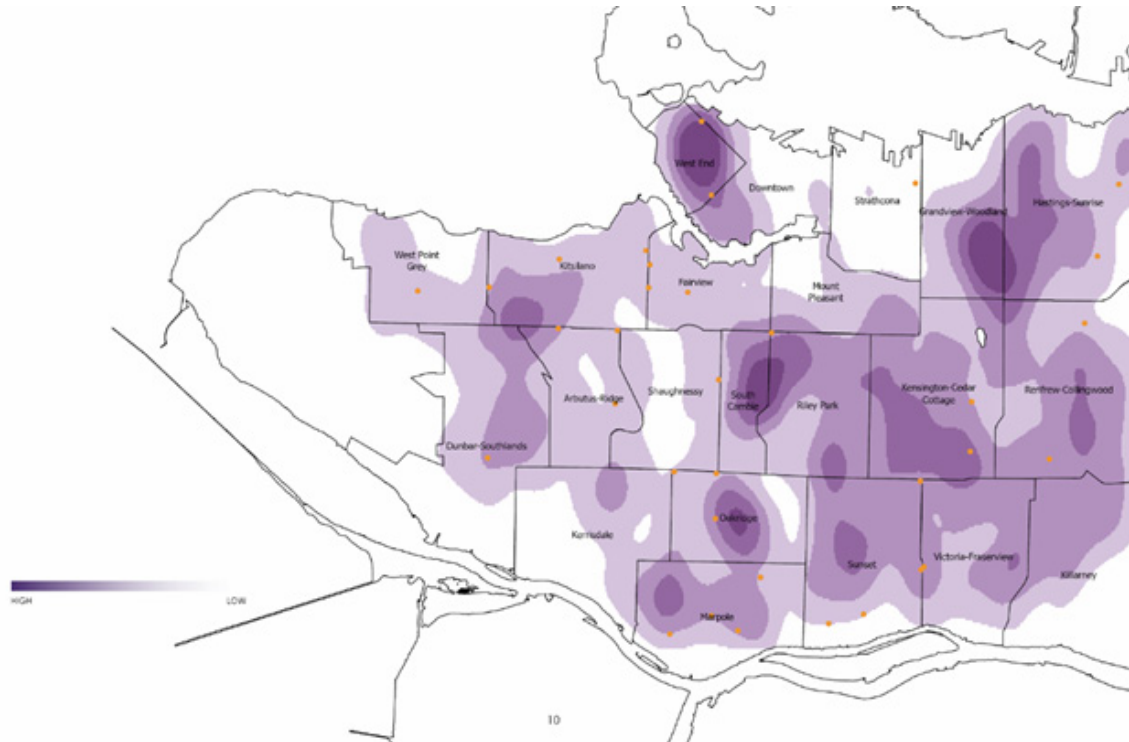

Areas in Vancouver experience consistent population inflow (Data from Statistics Canada 2021)

### ***The Rest of the Social Data***

Visualize the rest of the social data, including population, household size, household income and lifestyle for the potential neighbourhood. For example, if the point is far from the centre, it is above the average. If the point is close to the centre, the matrix is below average. Shown in the chart on following page.

In the diagrams below, the further the anchor is away from the center; the more data is above average level. (E.g. West End has a high population, a high number of couples without children, a high number of small households, and lower than average income.)



Visualizing social data of potential project neighbourhoods (Data from Statistics Canada 2021)

## Data Analysis and Results

After comparing matrices, the project will be located in the Kensington Cedar College neighbourhood. In the past decade, this neighbourhood experienced continuous population inflow. Today, it has the highest youth population, many large households, new families and a lower-than-average household income. The project is a gas station in the middle of a culturally divided residential neighbourhood.

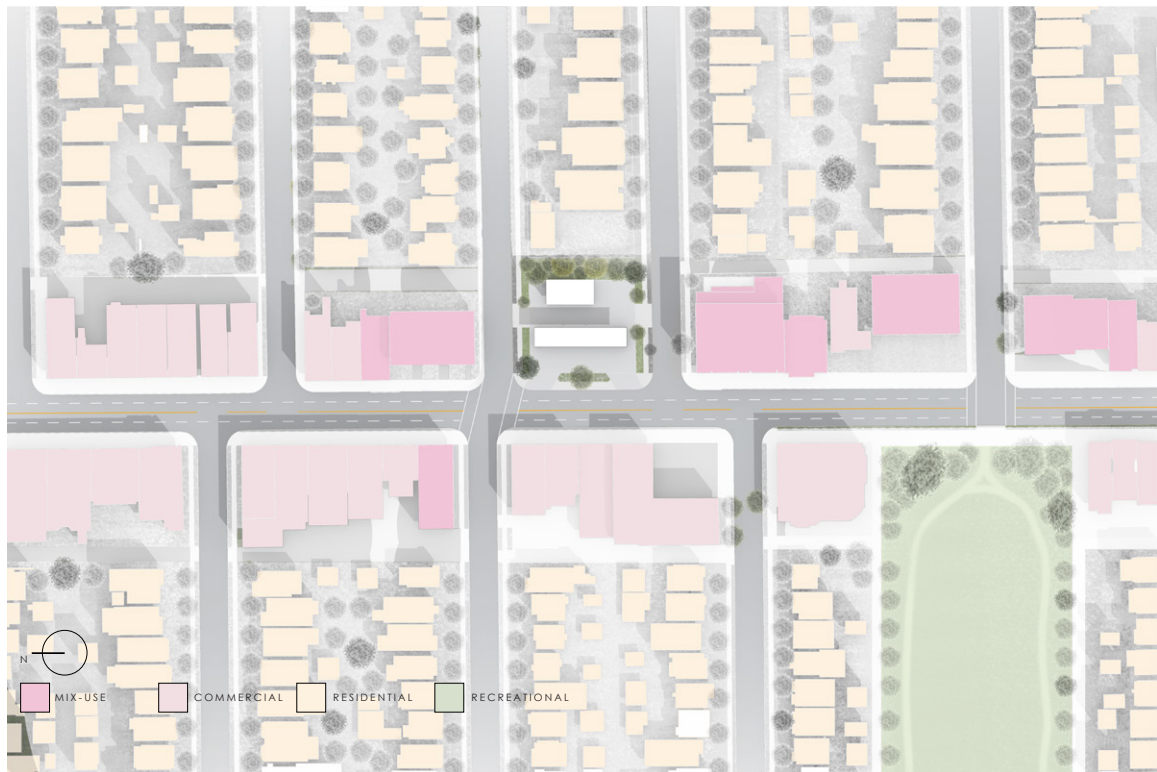

Site analysis of building use (base map from Statistics Canada 2021).

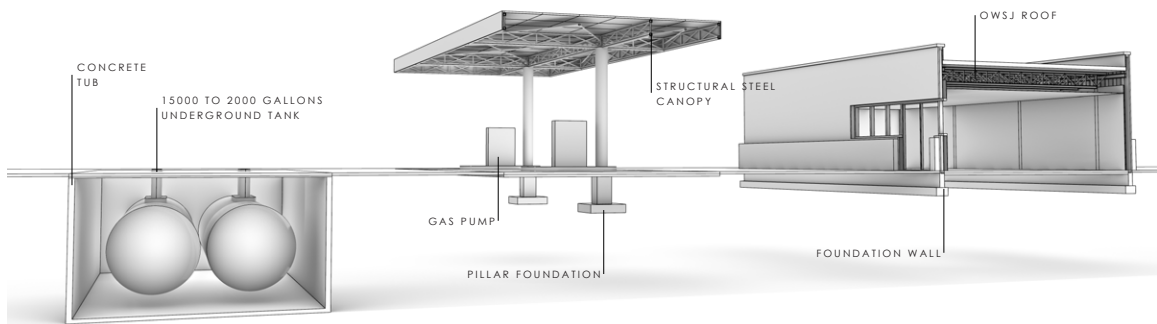

Existing gas station structure on site.

## Chapter 4: Design Project

### Design Concept

#### Trace—Palimpsest

The term “palimpsest” is derived from the ancient Greek word *palimpsestos*, meaning “a cloth that has been scraped clean and reused” (Merriam-Webster Dictionary 2022). The palimpsest is a manuscript in which the original information is removed and covered by new information. However, the original information is not always removed efficiently, so the trace of the previous information may still be visible. An example of palimpsest is shown in the photograph below . In today’s culture, a palimpsest is any text upon which subsequent texts have been written; it can refer to physical artifacts like books or paintings or describe words or ideas that have been reused in later texts. In the literary world, a palimpsest is an idea from previous authors’ work that writers continuously build upon by using their themes and ideas (Cambridge Dictionary, 2022).

Unlike the traditional design process that ends upon completion of construction, the palimpsest process never concludes. Instead, the project will be designed in a time-phased manner. This allows the project to be designed based on what we know about the near-term demand, but there remains the possibility to be developed if the demands shift in the future.

This project will take place on the site of an abandoned gas station. The project will be built as a continuation of the gas station to acknowledge the past and use design intervention to lay a foundation for the future direction. The later design interventions will seek opportunities to preserve the trace of

precious design and reuse and repurpose previous design features. Each future stage is built as a prolongation of the previous building. In this case, the design could be extended for future use and allow the design to be flexible enough to adapt along the way.



Scan of a medieval manuscripts, 2019; by photograph Melissa Moreton (Moreton 2019)

### **From Plug-N-Go to Plug-N-Play**

This project will build on the gas stations by reusing and repurposing the existing structure and acknowledging how gas stations operated in the past to establish a trace of the history through the physical form that inhabitants can see and feel. As a business, gas stations are designed for efficiency. Therefore, the gas station layout is designed for easy maneuvering of cars. There are typically four entrances around the site, so cars can pull in, refill, and leave linearly, no reverse needed; this is also known as the “plug-n-go” model.

Consequently, the proposed project will pay homage to how the gas station was operated in the past by incorporating the “plug-n-play” idea into the new proposal. However, this time,

the “unit” plugged in is not a personal vehicle but a functional unit that provides occupants with shelter for a temporary program that links the previous and future phases.

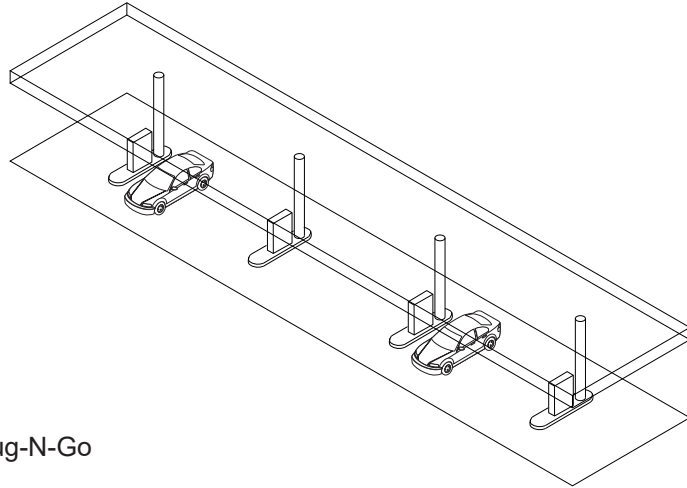

Plug-N-Go

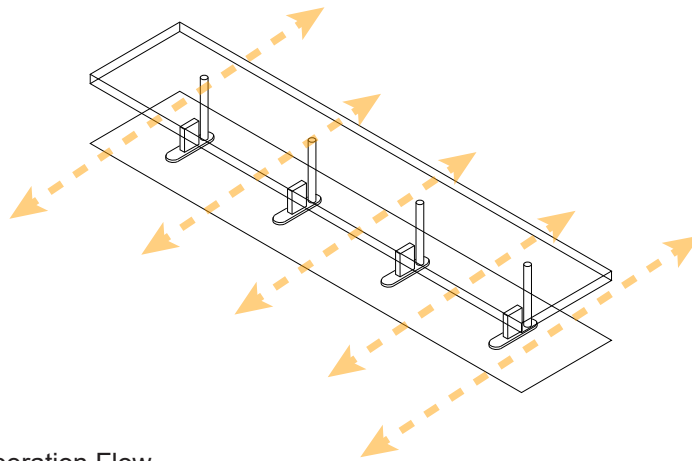

Operation Flow

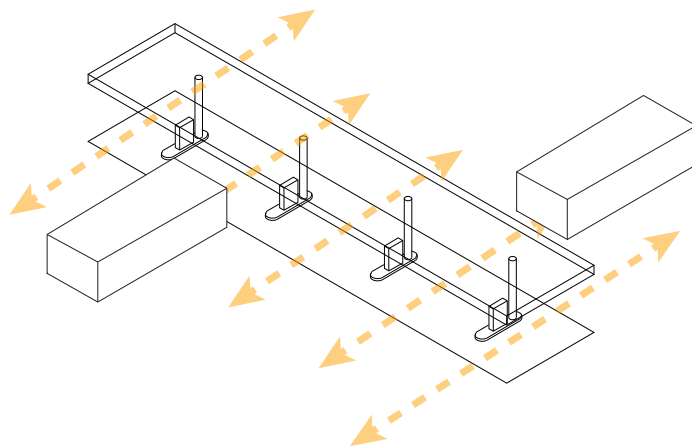

Plug-N-Play

## **Design Approach**

### **Time-Phased Design**

To embrace the change, the designer must first realize and accept that the only constant is change . Based on the previous chapter and theories, to ensure the design can withstand the change of time, the design must also change with time and react to potential changes in the future. In other words, the building must be designed with an open end to allow change and to evolve over time based on the community's needs.

However, as the previous chapter has established, it is impossible to predict the future. As much as designers and architects want their buildings to be future-proof, they must allow temporary characteristics. Although designers and architects want to offer comprehensive design solutions, they must also recognize that the more specificity the design offers, the more difficult it is for the design to adapt to potential future changes. Therefore, we should take a step back and try to analyze what will happen in the future and switch our perspective to what could happen and how the design decisions one made in each phase allow and encourage change. Norman Foster said, "The ultimately sustainable building is a building that you can recycle. Instead of demolishing the building, you can adapt it to change. The challenge is to do buildings which encourage change, which respond to change and to have technologies and techniques which enable buildings to improve their performance" (Marianne 2022).

The key emphasis of this project is not on the final form of the design because there should not be any. After all, the future is unknown. Nevertheless, this project aims to outline



the process of a time-phased design approach that allows the design to take place along with the change of time. Allowing each design intervention to happen builds on the previous design. It leaves enough room for the project to be developed by constantly analyzing the needs of society. The project timeline is shown in the table on the following page.

### **Development Process**

The time-phased design approach typically involves the following steps.

**Needs assessment:** Conduct a comprehensive needs assessment to identify the current and future needs of the project's users. The proposed project will consider the following criteria: population, the kids' population (zero to four years old), seniors' population (sixty-five and older), two-person households, five-or-more-person households, couples without kids, income, and commute time to work. Those criteria were chosen because they are the factors that drive the change.

**Conceptual design:** Develop a conceptual design that meets the project's current and future needs. This design should be flexible enough to accommodate changes that may occur over time, such as user needs or technological advances.

**Phase development:** Divide the project into phases that can be developed over time based on available funding and other factors. Each phase should be designed to be functional and independent so that it can be used on its own, even if the entire project is not yet complete.

**Implementation:** Implement each phase, focusing on meeting the users' immediate needs while ensuring that

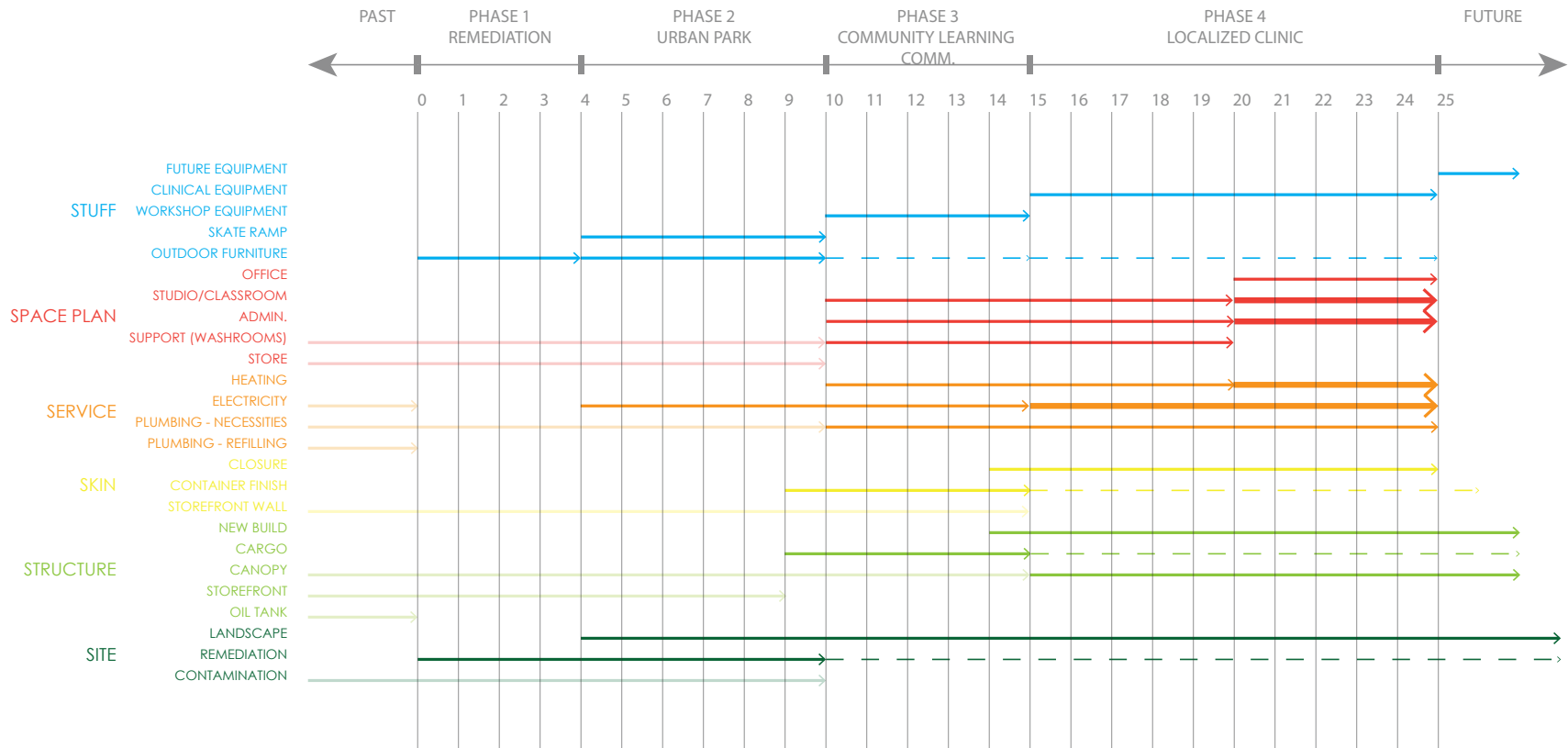

Project timeline - applying a time-phased design approach to project layer

the design is consistent with the overall conceptual design. As each phase is completed, it should be evaluated by the users to ensure it meets the needs of the users and is consistent with the overall design.

Future phases: Develop future phases (as funding becomes available) that build on the work already completed. This allows the project to evolve as the users' needs change.

## **Project Development**

As stated in the previous chapter, we cannot deny that every site we build on has its past. One could pretend it does not exist by ignoring it or covering its history, but that would be irresponsible. Therefore, the project will start with the remediation process. This process is a necessary logistic step because of the petroleum contamination introduced by the past operation. Nevertheless, from a design perspective, this gesture will acknowledge the site's past and environmental damage.

### **Phase 1: Remediation**

Phase 1 of the project is meant to establish the foundation for future development. According to the shearing layers and open building theory, the site is the building layer that lasts the longest. Therefore, the priority of Phase 1 is to control the existing contamination by preventing the pollutant from bleaching into the adjacent properties through underground water. Phase 1 will remediate the site and ensure it is safe for future programs. To remediate the site, we first need to remove the underground oil tanks properly, the primary source of contamination. Then, to create a buffer between the contaminated soil and the inhabitants, we will plant petroleum-tolerant grass wherever the soil is exposed.

Phytoremediation was chosen for this project because it is a form of environmental remediation that uses plants to remove or detoxify pollutants from contaminated soil, water, or air. It is a natural and sustainable way to clean contaminated sites. Phytoremediation can provide a sustainable and cost-effective alternative to traditional remediation methods. It has the potential to transform contaminated sites into productive and healthy ecosystems while also providing numerous ecological and social benefits. Therefore, it has been increasingly used as an alternative to traditional remediation methods, which can be costly and have negative environmental impacts (Kennen and Kirkwood 2015).

Taking notes from the structuralism theory, one should approach adaptive design through repeatable patterns and grids. I extracted the grid from the existing gas station canopy, subdivided the grid, and projected the grid to the entire site. This grid would guide the landscape design, where the existing ground cover is removed and replaced by petroleum-tolerant grass; this technique is known as the stabilization mat. Those plants, including tall grass, shrubs, and flowers, will be used to break down toxic chemicals and as landscape features.

The airflow buffer and living fence techniques will be applied to the perimeter of the site. An airflow buffer is a group of mature tree plants on the east side of the site; the purpose of the buffer is to prevent airborne pollutants from being blown to the surrounding neighbourhood by the wind. Additionally, under the ground surface, the roots system of the plants will stop dissolved pollutants from spreading to nearby properties through underground water.

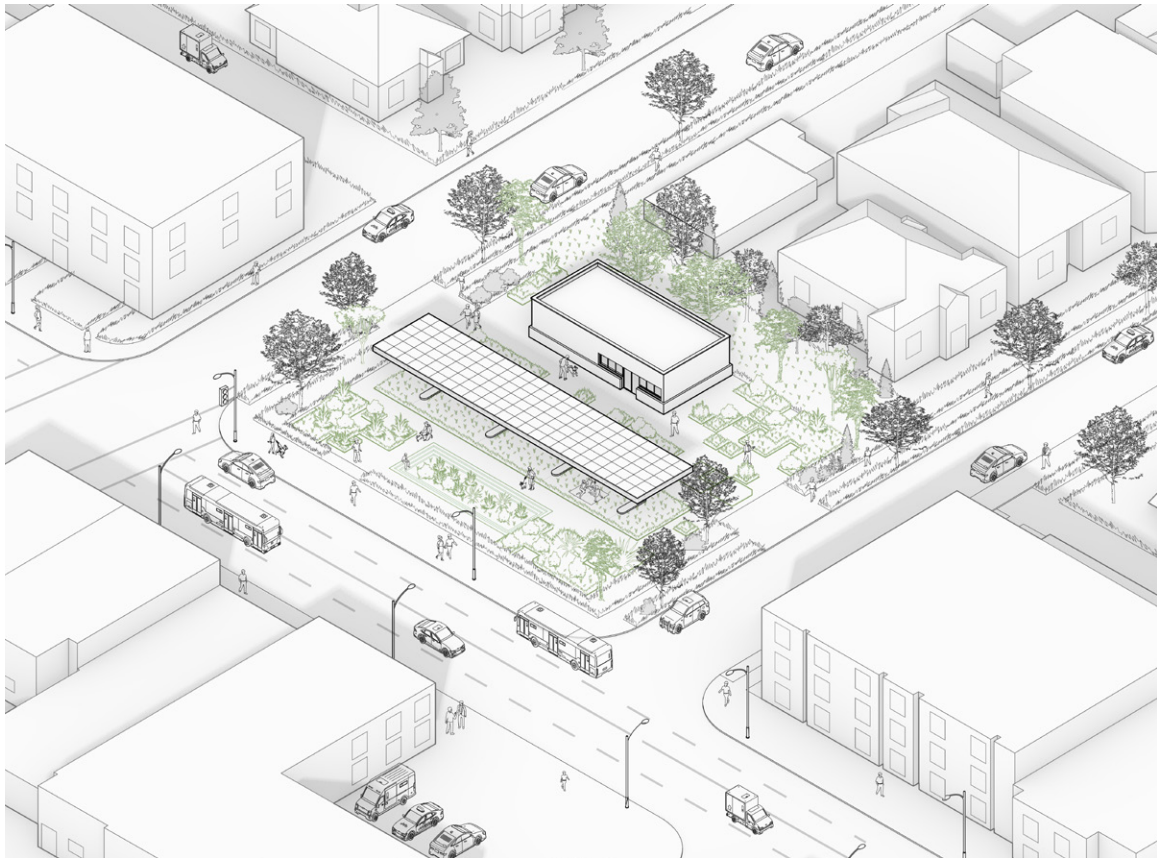

Axonometric drawing of Phase 1 remediation stage



Street perspective view 1, showing the remediation plants along the street



Street perspective view 2 showing the process of ground work for remediation



Rendering of column meet remediation grass

### ***Phytoremediation***

Phytoremediation works by taking advantage of the ability of certain plants to absorb, accumulate, and metabolize pollutants. Plants can break down, degrade, or transform contaminants through various biological and chemical processes, such as phytotransformation, phytoextraction, phytostabilization, and phytodegradation.

- Phytotransformation—The breakdown of pollutants by plants through metabolic processes, such as enzymes or microbial interactions.
- Phytoextraction—The uptake of pollutants by plants and their accumulation in above-ground tissues, which can then be harvested and disposed of safely.
- Phytostabilization—Using plants to immobilize soil pollutants reduces their mobility and potential for leaching into groundwater.

- Phytodegradation—Using plants to break down pollutants into less toxic or nontoxic substances through metabolic processes.
- Phytoremediation—Used to address a wide range of contaminants, such as heavy metals, organic compounds, and radionuclides . It is typically used in conjunction with other remediation methods, such as soil vapour extraction, pump and treat, or in-situ chemical oxidation, to achieve a comprehensive and practical cleanup of contaminated sites (Slegers and Hisle 2018).
- Phytoremediation—A versatile technology that can be applied to a variety of environmental pollutants, including heavy metals, organic pollutants, nutrients and sediments, and radionuclides (Kennen and Kirkwood 2015).

However, the effectiveness of phytoremediation depends on several factors, such as the type and concentration of the pollutant, the characteristics of the soil or water, the plant species used, and the environmental conditions. Therefore, selecting appropriate plant species, monitoring plant growth and pollutant removal, and integrating with other remediation methods may be necessary to achieve optimal results.



Plans for phase 1 that indicates where and what phytoremediation techniques are used on site.

## **Phase 2: Urban Park (Meet Each Other )**

According to Kennen and Kirkwood (2015), authors of *Phyto: Principles and Resources for Site Remediation and Landscape Design*, the remediation process will take about ten years. Remediated petroleum contamination would require roughly ten years, and the first four years is to let the plants grow to maturity and adjust to the new environment. Meanwhile, the site will serve as an urban park that provides the community with a place for people of all age groups to hang out.

The canopy and storefront will remain on-site during this process to provide shelter from the weather and necessary services to the occupant, such as washrooms, thus allowing visitors a more extended stay and expanding the opportunities to interact with others. One of the critical interventions in this phase is installing a skate ramp by repurposing the leftover pit from removing the oil tank. The skate ramp provides activity opportunities that separate this urban park from the rest of the green spaces around the city. Additionally, attracting people of different age groups to the site creates interaction opportunities between older adults and younger generations.

To further revitalize the site and bring new life to the old structure, local artists will repaint the underside of the canopy and the columns. Additionally, raised planters with more aesthetically pleasing flowers will be installed and planted, following the underlay grids established in Phase 1. Some grass mats and shrubs from Phase 1 will be trimmed back and removed, allowing better circulation on-site and encouraging visitors to explore on their terms. Engineered





Axonometric drawing of Phase 2 urban park. Different colors are used to distinguish different phases of the project.



Street perspective view, shown the newly built skateboard ramp and newly painted canopy



Perspective view, showing the kids play in the newly built skateboard ramp and newly painted canopy



Rendering showing the activities under the canopy

wood fiber will replace the vegetation beneath the gas station canopy. The area around the skateboard ramp will likely be more active, and other parts of the park will be quieter, thus allowing small groups to gather; the planters also offer additional seat capacity around the park.

### **Phase 3: Community Learning Center (Learn from Each Other )**

After the remediation process (roughly ten years), the community and its residents will have grown as well. Based

on the current social data, there will be a high number of kids; by Phase 3, the community will likely have a high teen population. Thus, the project will expand its program to adjust to the community's needs. As kids grow into teens and adults, this would be an excellent opportunity to introduce a community hub for education and skill training. Kids who live in the neighbourhood could come here to learn various skills after school, on the weekends, or during school breaks. Furthermore, the community would determine the program through surveys and community meetings, which will reflect the community's needs, such as a woodshop, repair shop, or art studio.

As a result of the program's flexible nature, the program's host structure will also be flexible. A temporary structure will protect the site's potential and keep its adjustable, convertible, and versatile character, inspired by metabolism architects' approach of moveable prefabricated units. In this context, the project will repurpose shipping containers from local shipping yards and insert them into the existing canopy structure. The containers will be brought in through cranes and set on metal supports. The modular shipping containers can start serving their purpose with minimal alternation on-site. Multiple containers can be rearranged and connected to create a larger space for studios and workshops. Moreover, the container workshops can be swapped between other adaptive reuse gas stations in different neighbourhoods.

The project will also use Phase 3 to reinforce and renovate the existing canopy. At the same time, the canopy would offer coverage from weather elements, thus allowing the additional outdoor workspace to take place under the canopy. This idea of creating interactions between the inhabitants and unfinished structure is inspired by Cedric Price's work,

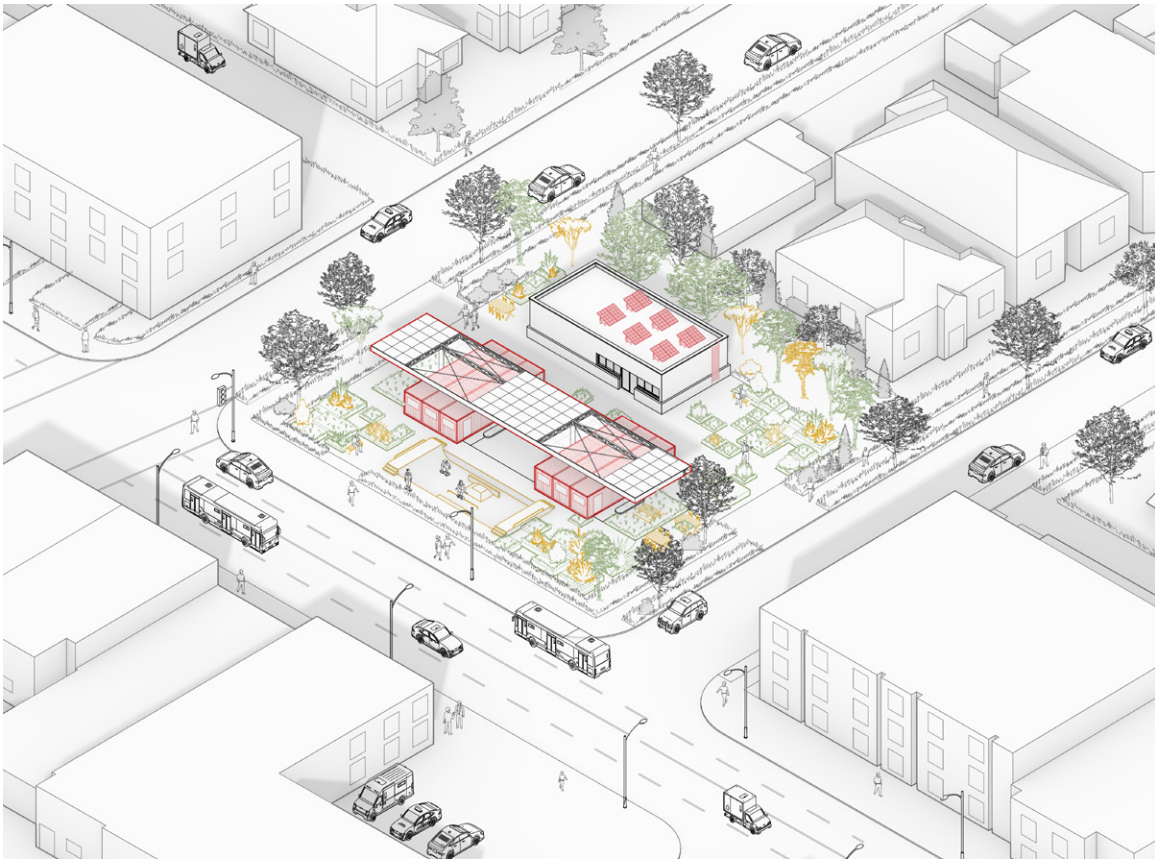

Axonometric drawing of phase 3 Community Learning Center. Different colors are used to distinguish different phases of the project.



Street perspective view, showing the containers workshops and studios under the canopy



Perspective view showing the outdoor working area under the canopy



Perspective view showing the outdoor working area under the canopy at the end

Inter-Action Centre, in that open structure creates a sense of space but does not limit its usage. Finally , Phase 3 is the transition point of the project; while the community learning center is running, the community will host surveys and meetings to decide the future program for the project.

#### **Phase 4: Localized Clinic (Take Care of Each Other )**

Based on the future projection of today's social data, at Phase 4, the neighbourhood will start experiencing a high senior population, leading the program to transform into a

decentralized clinic to respond to the community's future change.

In preparation for Phase 4, foundation reinforcing will be implicated on the perimeter of the canopy, and the skateboard ramp will be removed to free space on-site. Then, a new canopy will be added to connect the storefront and gas station canopy, combining the two separate structures and turning them into one structure. The back side of the structure (previous storefront) will become residence doctors' offices, exam rooms, and a medicine storage room. This design move places the office far away from the busy street for noise and privacy concerns. The new canopy that connects the two structures will be the waiting room, where patients can be seated before their doctor visit. This new waiting area also has direct views of the garden between the canopy and offices.

The new design ensures that the building envelope will not wrap around the existing structure so that the canopy can still be seen, and it would preserve the gas station's trace and aesthetic. The new structure will be built under the main canopy with a secondary roof. The gap between the two structures emphasizes and distinguishes between the new and existing. Furthermore, the clinic entrance is recessed to highlight the entry and break the facade.

The containers used in Phase 3 will be reused and relocated to preserve the trace of the previous phase and bring different styles to the building. However, because of the container's size and structural strength, the container will not sit directly on top of the existing structure. Therefore, an additional structure will be constructed prior to Phase 4. This structure will serve as a shelf for the containers to sit in. This

new structure will provide circulation for visitors to access the canopy. On top of the canopy, planters can be set up as an urban garden that contributes to food production.

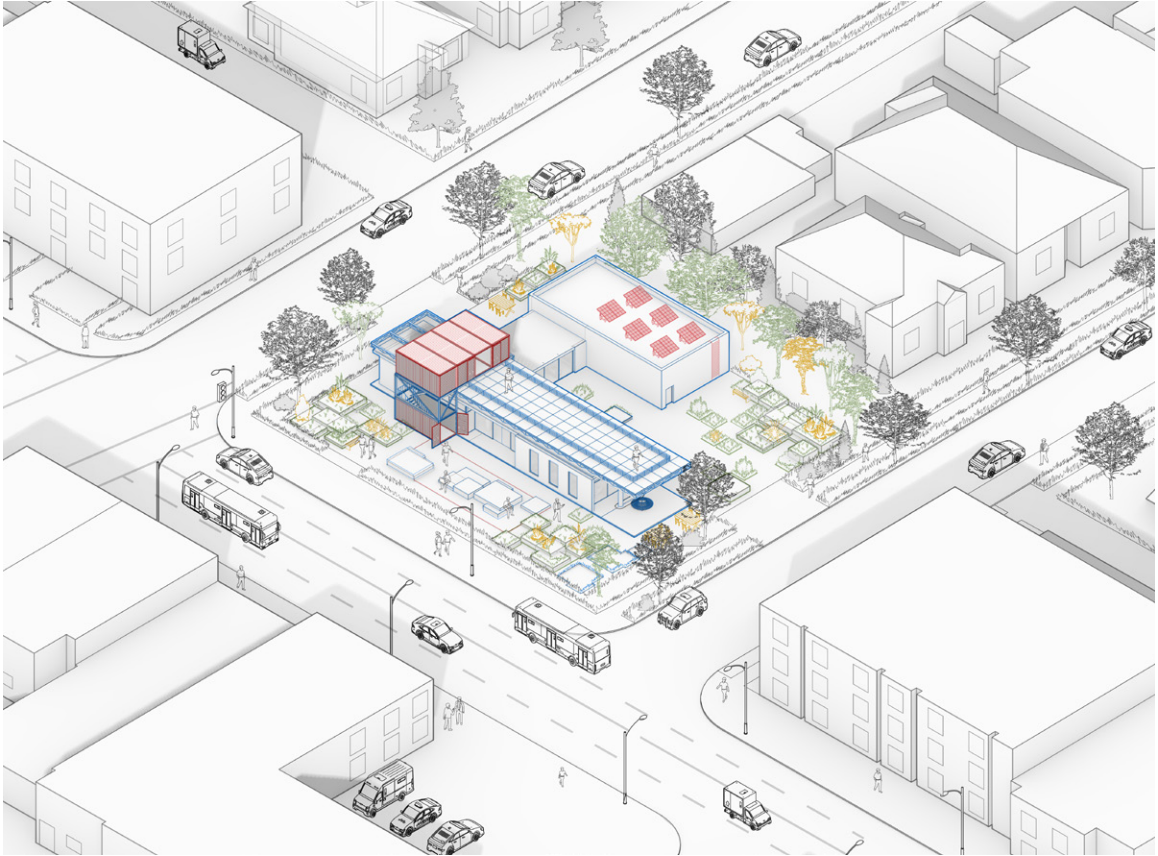

Axonometric drawing of phase 4 community health center. Different colors are used to distinguish different phases of the project.



Street perspective view, showing the community health center in phase 4



Perspective view showing the covered patio at the end of the canopy



Perspective view showing the garden between the canopy and the office



Plan of community health center constructed in phase 4

### Phase 5: Future Beyond

In Phase 5, when the community's future is beyond what we can predict or project from the current data, it will be time



for my project to meet its end and for someone to repeat the process. By re-collecting and reanalyzing the social data and redesigning, the architects should work with the residents to design another architecture best suited to the community's needs. Although it is impossible to predict the future program, the project could still fade away but still have its trace on site. Echoing the open building theory mentioned in the earlier chapters, the structure's skin layer, service, and stuff would be removed and disassembled. Moreover, it will leave a site free of contamination and steel structures that could still have approximately 50 years of life remaining. The remaining structure would still provide great opportunities to be adopted because of the high ceiling height and long-span structure.

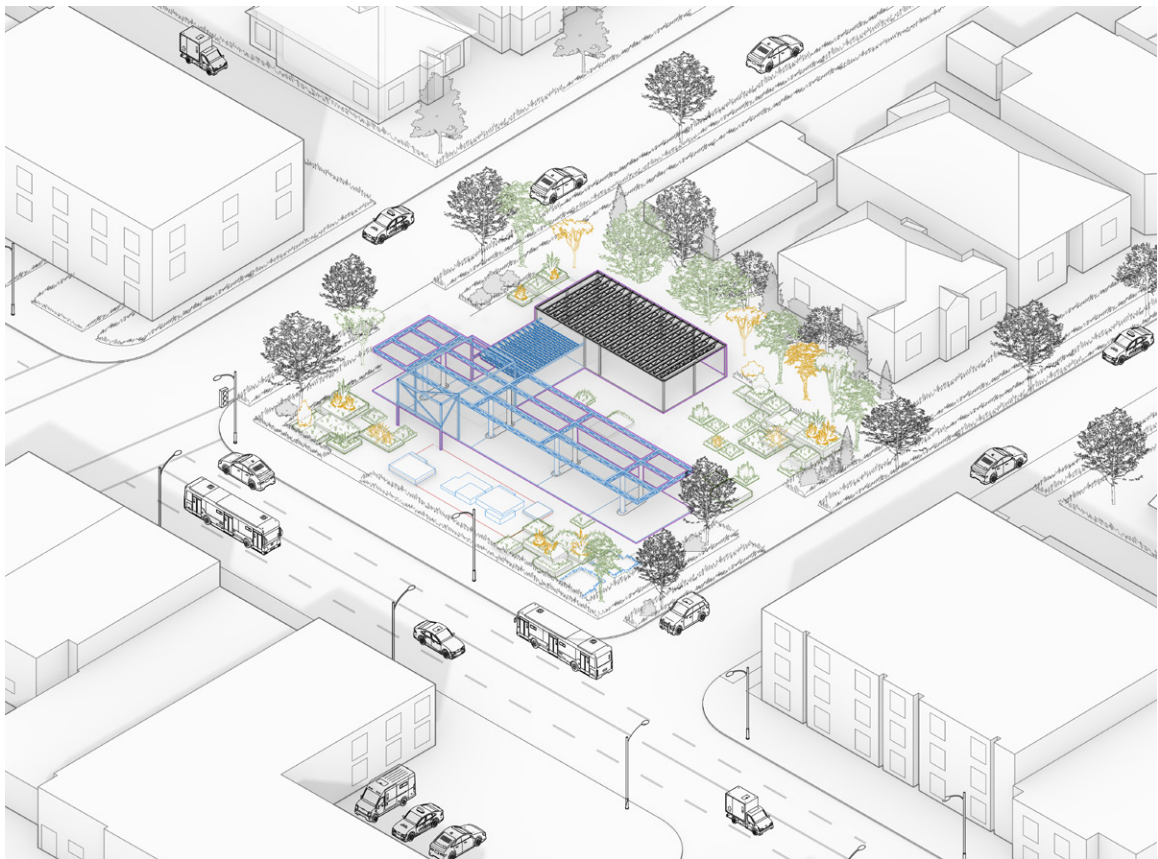

Axonometric drawing of phase 5 showing the remaining structure on site



Street perspective view 1, showing remaining structure in the future



Street perspective view 2, showing remaining structure in the future

## Project Sequences

The project shows the five key phases through time. However, there are necessary transition works needed between each phase. Such as site excavation, transporting the containers and additional structural reinforcement. The following diagrams demonstrate those interventions that are crucial for the project but not visible in the complete phases.

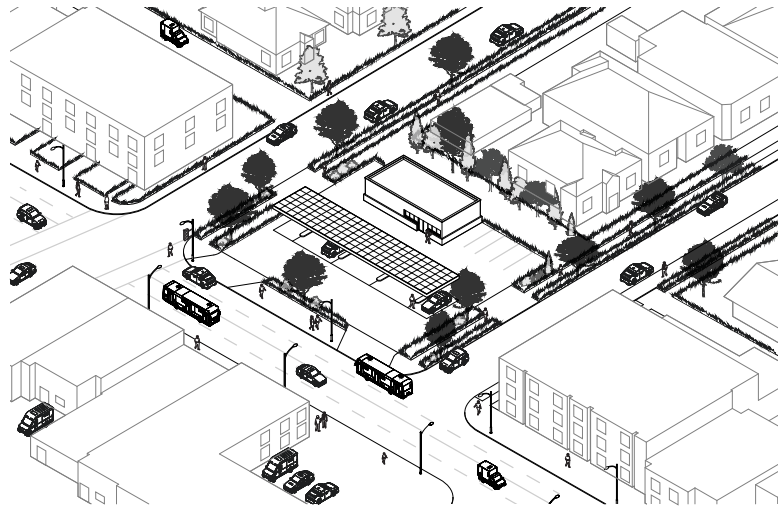

Existing gas station (current)

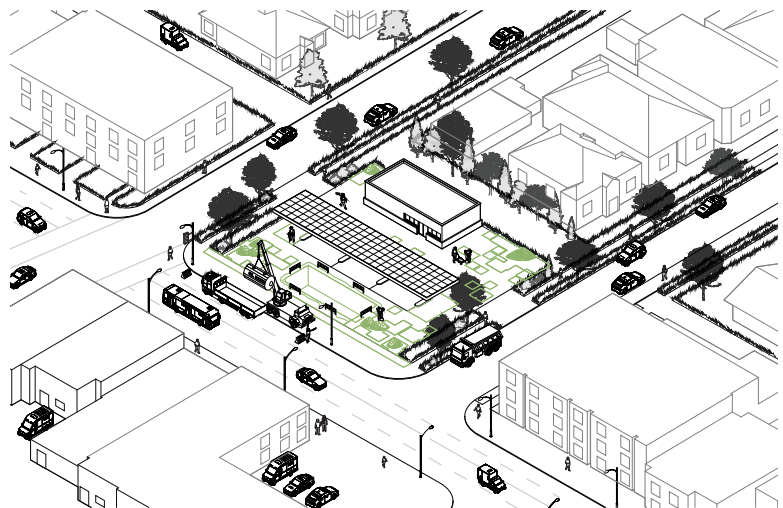

Site work stage and underground tank removal

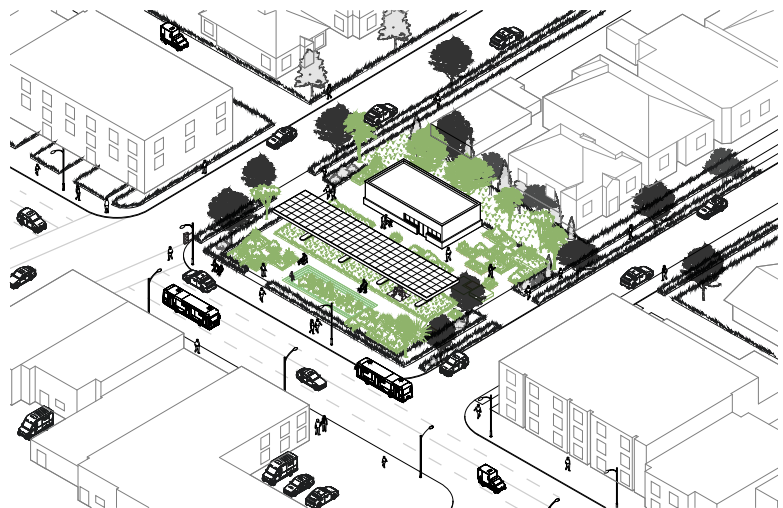

Remediation process

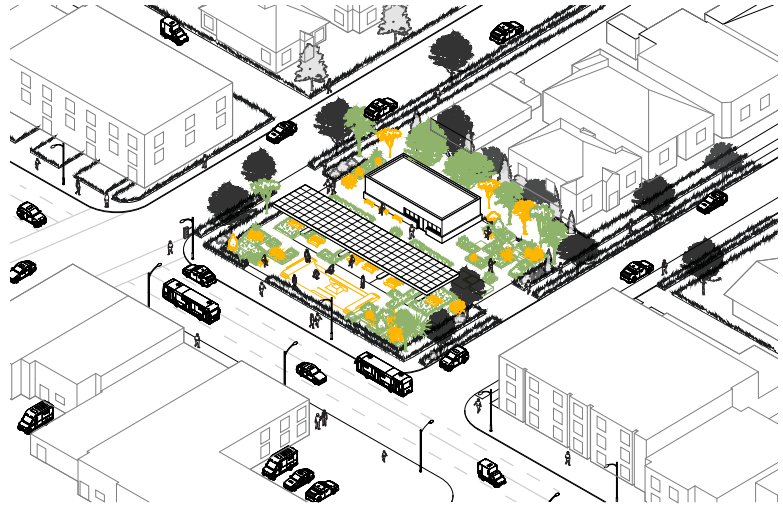

Urban park with skateboard ramp



Transporting the cargo on site



Community learning center with variety of workshops

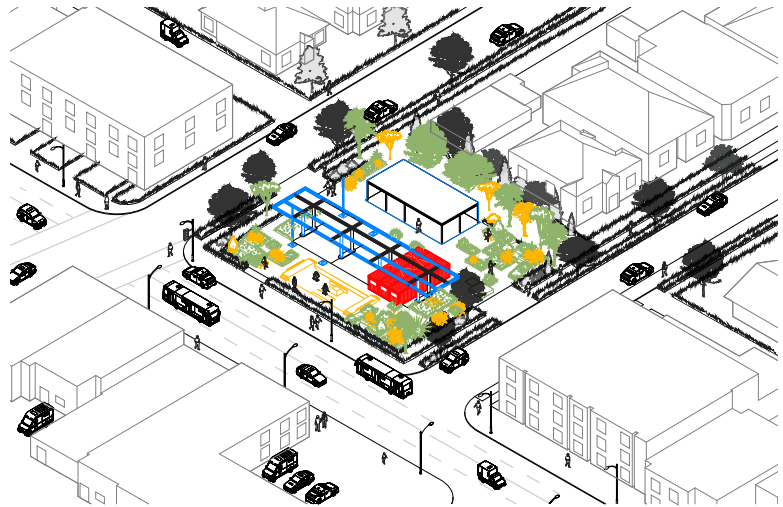

Foundation and structure reinforcing

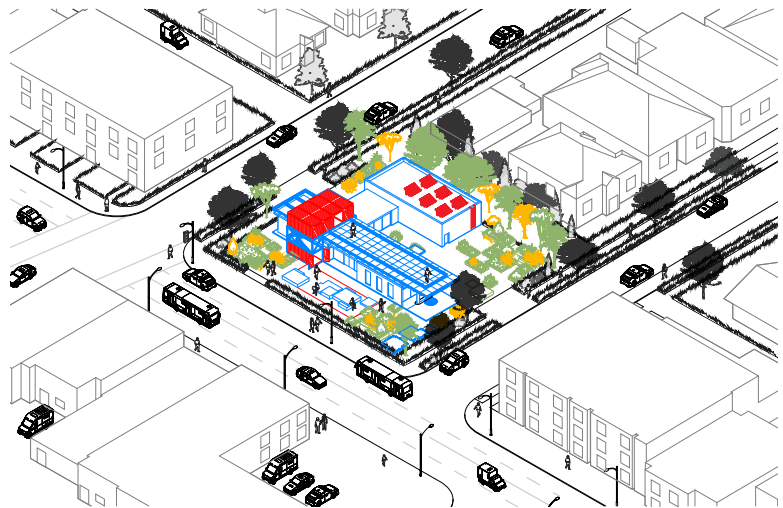

Proposed community health center in the future

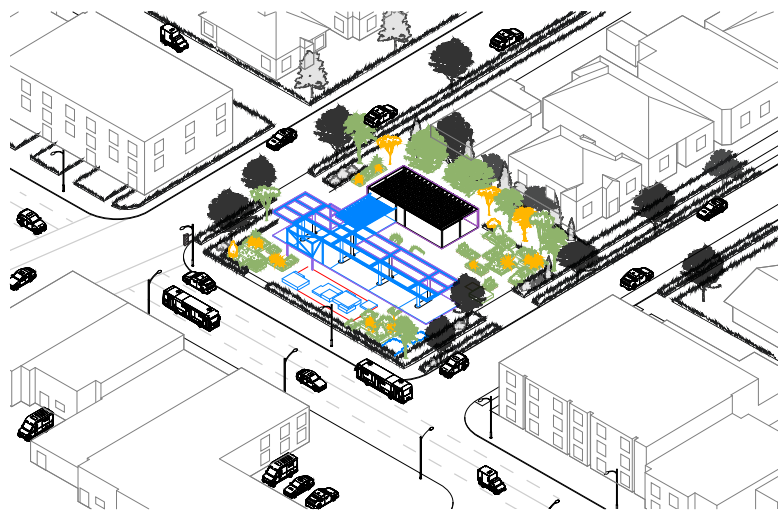

Future beyond

## Project Sequences in Sections

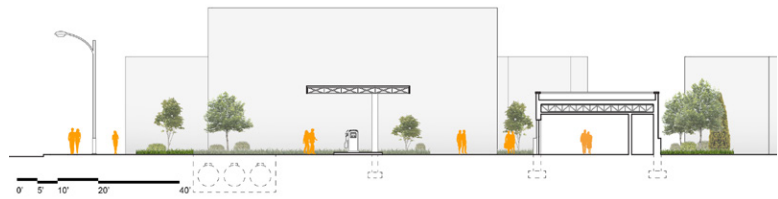

Existing gas station section



Phase 1 section



Phase 2 section

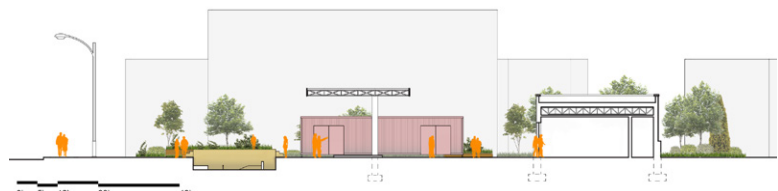

Phase 3 section



Phase 4 section

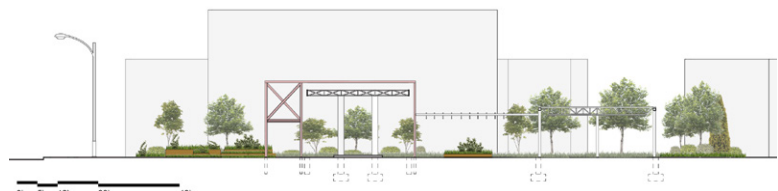

Phase 5 section

## Chapter 5: Conclusion

My initial motivation for this project was to identify the potential value of something from the past. Multiple factors drive social change, and each one moves according to its own cycle; at any moment, some are in an upward trend, and some are down . Some will interact with others, and the intersections will provide significant opportunities. Society needs to grow through innovations that replace outdated technology. However, we should try to give the remains of the past a second chance; rather than demolish, adaptive reuse can be the solution. In the context of this project, the declining trend is the number of gas stations , and the rising trend is the need for decentralized community service facilities. Therefore, for this project, I sought opportunities to convert decommissioned gas stations into community centers nationwide.

This approach is more feasible in larger cities, such as Toronto, Ottawa, and Vancouver, where the potential value of a future project is more than the sum cost of its remediation and redevelopment. However, as the nation's population increases, buildable land becomes increasingly scarce, and the increasing threat of climate change may drive innovations in remediation technology. Furthermore, it reduces the cost and complexity of remediation, so adaptive reuse decommissioned gas stations could be more economically viable in the country's small cities. Moreover, I learnt from my research that gas stations are efficient in their operations as a decentralized infrastructure system because they have existed and evolved in North America for over a century. We could learn from this decentralized model and apply it to our future urban design strategies.

Adaptive reuse should be the first choice when dealing with existing structures, and architects and designers should demolish existing structures only when there are no other options. However, adaptive reuse poses its own set of challenges, which I discovered during the development of this thesis project. For instance, designers and architects will face the duality of the existing and new structures, forcing them to make difficult decisions about what to keep, how much to keep, and how to let the existing structure coexist with the new one without losing the structure's architectural identity. Second, the classic architectural idea of Mies Van der Rohe, the clean grids, in which everything lined up with everything else, will probably not work in adaptive reuse architecture. Because architects do not have control over what was there before, designers can readapt only what was there, which could be anything.

For instance, my project's gas station's canopy is slightly off and does not align with the existing storefront. Additionally, according to the drawings provided by Chevron Oil and GIS data from the City of Vancouver, the dimensions of the existing structure are not whole numbers. Finally, because of the change in their programs and use, some spaces are not converted efficiently during adaptive reuse, which could influence their operational performances.

Overall, this project's success should be examined from two perspectives. The first perspective involves the program of architecture. In other words, how well the proposed program matches and mirrors communities' needs through analyzing data reflects their needs. Furthermore, this process of reflection and testing should occur periodically throughout the project to ensure the program always meets the communities' needs. Community input is also crucial to



the project's future development direction if it is undertaken in the real world. This could happen in several ways, such as through regular community meetings and surveys.

However, the project's architectural design should be examined to determine whether the intervention expands opportunities for architecture development or limits its potential to change. I learnt through working on this project that, as designers or architects, we would love to provide as much as possible to the inhabitants, but a more precisely designed space requires more consideration during the design process. The designer needs to think about how the architectural structure will be used today and, more important, how the space can be further adapted and reused in the future. It is a fine line to walk, and compromises may be needed.

Although this thesis explored only adaptive reuse in a gas station in Vancouver, the adaptive reuse approach could also apply to other sites during the initial development stage of the thesis. I have also considered watchtowers for monitoring forest fires. Because of technological innovations, forest departments started to use drones and satellites to observe forest fires, leading to traditional watchtowers' obsolescence. Thus, one could explore opportunities to convert watchtowers for other uses, such as protecting wildlife.

## References

- Archis. 2015. "Cedric Price: The Dynamics of Time." *Archis*. <https://archis.org/volume/cedric-price-the-dynamics-of-time/>.
- Asimov, Isaac. 2004. *Prelude to Foundation*. New York: Bantan Books.
- Asselt, Marjolein B. A. van, and Ellen Vos. 2006. "The Precautionary Principle and the Uncertainty Paradox." *Journal of Risk Research* 9 no. 4: 313–36. <https://doi.org/10.1080/13669870500175063>.
- Aureli, Pier Vittorio. 2011. "Labor and Architecture: Revisiting Cedric Price's Potteries Thinkbelt." *Log* 23: 97–118.
- Baan, Iwan. 2020. "Sky House by Kiyonori Kikutake: A Masterpiece of Japanese Modernism." *ArchEyes*. <https://archeyes.com/sky-house-kiyonori-kikutake/>.
- Brand, Stewart. 1995. *How Buildings Learn: What Happens after They're Built*. New York: Penguin Books.
- Brand, Stewart. 2015. *Pace Layer Thinkers: Stewart Brand and Paul Saffo's Conversation at The Interval*. Long Now Foundation. <https://longnow.org/ideas/pace-layers-stewart-brand-paul-saffos-conversations-at-the-interval/>.
- Brütting, Jan, Gennaro Senatore, and Corentin Fivet. 2021. "Design and Fabrication of a Reusable Kit of Parts for Diverse Structures." *Automation in Construction* 125 (May): 103614. <https://doi.org/10.1016/j.autcon.2021.103614>.
- Canadian Association of Petroleum Producers. 2020. Rep. *Statistical Handbook for Canada's Upstream Petroleum Industry* February 2020.
- Chan, Hugo. 2022. "Don't Treat Buildings Like Lifeless Objects." *Design Cost Data* 66, no. 5: 44–45.
- Cho, Hyunjung, and Chunghoon Shin. 2014. "Metabolism and Cold War Architecture." *The Journal of Architecture* 19, no. 5: 623–44. <https://doi.org/10.1080/13602365.2014.965186>.
- Conejos, Sheila, Craig Langston, and Jim Smith. 2014. "Designing for Better Building Adaptability: A Comparison of AdaptSTAR and ARP Models." *Habitat International* 41: 85–91. <https://doi.org/10.1016/j.habitatint.2013.07.002>.
- Crockett, Zachary. 2022. "Why Most Gas Stations Don't Make Money from Selling Gas." *The Hustle*. <https://thehustle.co/why-most-gas-stations-dont-make-money-from-selling-gas/>.

- DOMUS. 2022. "When Kisho Kurokawa's Nakagin Capsule Tower Premiered on Domus." *DOMUS*. <https://www.domusweb.it/en/from-the-archive/2010/12/21/kurokawa-s-capsules.html>.
- "Ecological Footprint". 2022. Global Footprint Network. <https://www.footprintnetwork.org/our-work/ecological-footprint/>.
- Fracalossi, Igor. 2019. "Architecture Classics: Amsterdam Orphanage / Aldo Van Eyck." *ArchDaily*. <https://www.archdaily.com/151566/ad-classics-amsterdam-orphanage-aldo-van-eyck>.
- Greene, Travis. 2020. "Intro to Post-Structuralist French Philosophy for Data Scientists (Part II)." *Medium*. <https://towardsdatascience.com/intro-to-post-structuralist-french-philosophy-for-data-scientists-part-ii-d00cd8194174>.
- Gross, Daniel. 2016. "America's Gas Stations Are Running Out of Time." *Slate Magazine*. June 10. <https://slate.com/business/2016/06/why-americas-gas-stations-are-running-out-of-time.html>.
- Heraclitus, and T. M. Robinson. 1991. *Heraclitus: Fragments*. Toronto: University of Toronto Press.
- Herdt, Tanja. 2021. "From Cybernetics to an Architecture of Ecology." *Footprint : Delft School of Design journal* 15, no. 1: 45-62
- Hertzberger, Herman. 2015. *Architecture and Structuralism: The Ordering of Space*. Rotterdam: nai010 Publ.
- Hidden Architecture. 2017. "Interaction Centre." *Hidden Architecture*. <https://hiddenarchitecture.net/interaction-centre/>.
- Hidden Architecture. 2021. "Potteries Thinkbelt Project." *Hidden Architecture*. <https://hiddenarchitecture.net/potteries-thinkbelt-project/>.
- Ikeda, Daisaku, René Simard, and Guy Bourgeault. 2001. *On Being Human: Where Medicine, Ethics and Spirituality Converge*. Montréal: Les Presses de l'Université de Montréal.
- Jansen, Emily, and Kathleen Flear. 2022. "Are Gas Stations as We Know Them a Dying Business". *GetJerry.com*. <https://getjerry.com/insights/are-gas-stations-dying-business#from-gas-station-to-charging-station>.
- Kennen, Kate, and Niall Kirkwood. 2015. *Phyto: Principles and Resources for Site Remediation and Landscape Design*. New York: Routledge.
- Koehler, Daniel. 2019. "Mereological Thinking: Figuring Realities within Urban Form." *Architectural Design* 89, no. 2: 30–37. <https://doi.org/10.1002/ad.2409>.

- Koolhaas, Rem. 2011. *Project Japan: Metabolism Talks*. Cologne: Taschen.
- Little, William. 2016. *Introduction to Sociology*. Victoria: BCcampus.
- Marianne, Flora. 2022. "The Role of Adaptive Reuse in the Cultural Preservation of a Building". *Rethinking The Future*. Blog. May 18, 2022. <https://www.re-thinkingthefuture.com/architectural-community/a6929-the-role-of-adaptive-reuse-in-the-cultural-preservation-of-a-building/>.
- Marsh, Rob. 2017. "Building Lifespan: Effect on the Environmental Impact of Building Components in a Danish Perspective." *Architectural Engineering and Design Management* 13, no. 2: 80–100. <https://doi.org/10.1080/17452007.2016.1205471>.
- McCurry, Justin. 2023. "Legacy of Japan's Nakagin Capsule Tower Lives on in Restored Pods." *The Guardian*, January 6, 2023, sec. <https://www.theguardian.com/world/2023/jan/06/legacy-japan-nagakin-capsule-tower-lives-on-restored-pods>.
- Menges, Achim, and Sean Ahlquist, eds. 2011. *Computational Design Thinking*. Chichester: Wiley.
- Moreton, Melissa. 2019. "Seeing the Invisible - Multispectral Imaging of Ancient and Medieval Manuscripts." *HMML*. <https://hmml.org/stories/seeing-invisible-multispectral-imaging-ancient-medieval-manuscripts/>.
- Muresan, Alex, Jan Brütting, Dario Redaelli, and Corentin Fivet. 2020. "Sustainability through Reuse: A Reconfigurable Structural System for Residential and Office Buildings." IOP Conference Series: *Earth and Environmental Science* 588 no. 4: 042066. <https://doi.org/10.1088/1755-1315/588/4/042066>.
- Nascimento, Denise Morado. 2012. "N. J. Habraken Explains the Potential of the Open Building Approach in Architectural Practice." *Open House International* 37, no. 4: 5–13.
- Pae, Hye K. 2020. *Script Effects as the Hidden Drive of the Mind, Cognition, and Culture*. Berlin: Springer International Publishing.
- Patterson, Ashleigh. 2009. "Canadian Gas Stations in Decline: Survey." *The Globe and Mail*, May 7, 2009. <https://www.theglobeandmail.com/report-on-business/canadian-gas-stations-in-decline-survey/article1197261/>.
- Pourebrahimi, Mohammad, Seyed Rahman Eghbali, and Ana Pereira Roders. 2020. "Identifying Building Obsolescence: Towards Increasing Buildings' Service Life." *International Journal of Building Pathology and Adaptation* 38, no. 5: 635–52. <https://doi.org/10.1108/IJBPA-08-2019-0068>.
- Price, Cedric, and Hans Ulrich Obrist. 2003. *Re CP*. Basel, Boston: Birkhauser.

- Rinke, Mario, and Robbe Pacquée. 2022. "Structures and Change – Tracing Adaptability Based on Structural Porosity in Converted Buildings." *Architecture, Structures and Construction* 2, no. 4: 699–710. <https://doi.org/10.1007/s44150-022-00054-9>.
- Salmon, Felix. 2022. "Gas Stations' Long Decline." *Axios*. <https://www.axios.com/2022/07/15/gas-stations-prices-closing>.
- Schmidt III, Robert, and Toru Eguchi. 2014. "Mediating Change: A Japanese Perspective on Adaptable Architecture." *Architectural Design* 84, no. 2: 74–79. <https://doi.org/10.1002/ad.1731>.
- Schneider, Henrique. 2019. "Wu-Wei: Acting without Desire." *1000-Word Philosophy: An Introductory Anthology*. Blog. June 3, 2019. <https://1000wordphilosophy.com/2019/06/03/wu-wei-acting-without-desire/>.
- Slegers, Frank, and Matthew Hisle. 2019. "Redesigning Abandoned Gas Stations Through Phytotechnologies." In *Phytoremediation*, 3–20. Cham: Springer International Publishing.
- Smith, Peter F. 2006. *Architecture in a Climate of Change: A Guide to Sustainable Design*. Oxford: Architectural Press.
- St Hill, Cate, ed. 2016. *This Is Temporary: How Transient Projects Are Redefining Architecture*. Newcastle upon Tyne: RIBA Publishing.
- Stigt, J. van. 1963. Eindkamp voor de Prix de Rome. *Forum voor Architectuur en Daarmee Verbonden Kunsten*, 17, no 1: 4-20.
- Swanson, Jason. 2021. "A Tool for Exploring Plausible, Probable, Possible and Preferred Futures." *Students at the Center*. KnowledgeWorks Foundation. February 24. <https://studentsatthecenterhub.org/resource/tool-exploring-plausible-probable-possible-preferred-futures/>.
- Tamari, Tomoko. 2014. "Metabolism: Utopian Urbanism and the Japanese Modern Architecture Movement." *Theory, Culture & Society* 31, no. 7–8: 201–25. <https://doi.org/10.1177/0263276414547777>.
- Torisson, Fredrik. 2023. "The Cybernetic Hypothesis and Architecture." *Histories of Post-war Architecture*. 1, no. 1: 54-68.
- Williams, Rhiona. 2018. "Cedric Price: Events in Time." *Cedric Price: Events in Time*. <https://rhionawilliams.com/2018/09/05/cedric-price-events-in-time/>.