

**Reducing CO₂ Emissions Through Natural Fibre: How Hemp can
Offset the Carbon Contribution from the Built Environment**

by

Mathew Rodrigues

Submitted in partial fulfilment of the requirements
for the degree of Master of Architecture

at

Dalhousie University
Halifax, Nova Scotia
March 2020

© Copyright by Mathew Rodrigues, 2020

Contents

List of Figures.....	v
Abstract	x
Acknowledgements	xi
Chapter 1: Introduction.....	1
Historical Use of Hemp Apart from Building Materials	1
Hemp as a Building Material.....	1
Why Growing Hemp is so Important.....	3
Growing Climate for Hemp	3
The Site	4
Connecting People to Hemp.....	6
Learning About Hemp Through Design	7
Chapter 2: Reducing CO ₂ Emissions by Natural Material	11
Why Embodied Carbon.....	11
High Impact Materials.....	13
Concrete	13
Steel.....	15
Wood	16
Insulation	19
Natural Alternatives in the Built Environment	20
Straw-bale.....	20
Bamboo	21
Hemp/Hempcrete.....	21
Chapter 3: Hemp Cultivation	23
Cannabis Varieties.....	23
History of Growing Hemp in Canada	24
Hemp Cultivation	25
Grow	25
Process.....	25
Farming Tools and Equipment.....	27
Social Impact.....	28

Chapter 4: Hempcrete Characteristics	30
Differences in the Hemp Hurd	32
Thermal Performance	33
Thermal Transmittance (U-value)	34
Sound Absorption	35
Hemp Acoustic Paneling.....	35
Vapour Permeability and Hygroscopicity	36
Strength	37
Cast-in-Place - Racking Strength	37
Block.....	38
Fire Resistance.....	39
Pests.....	41
Mould/Mildew	41
Binders	41
Applications for Hemp-Lime Mix.....	41
Lime Binder.....	42
Indoor Air Quality (Ventilation)	43
Cost	43
Material	43
Agricultural By-product	43
Labour.....	44
Problems with Hempcrete	44
Drawbacks to Exposing Hempcrete	45
Chapter 5: Hempcrete Construction.....	46
The Plinth	46
Pre-cast Hempcrete.....	48
Shuttering/ Formwork	50
Curved Walls	51
Details in Formwork.....	51
Spray-Applying	52
Blocks	52
Hemp Quilt.....	54

Wall.....	55
Wall Section	55
Wall-to-Roof	56
Floors.....	57
Tools and Equipment	59
Recommended Standard Toolkit.....	59
Framing and Shuttering Tools.....	59
Tools for Hempcrete Application	60
Tools for Plastering and Rendering	60
Chapter 6: Hempcrete Construction in Nova Scotia.....	62
Exterior Context and Material Palette	64
Hemps Cafe.....	64
Connect – The Haptic Nature of Hemp	64
Fitting Into the Existing Context.....	65
Fitting Into the Existing Site - Drainage	66
Acoustic Performance	68
Sharing Walls with Existing Buildings.....	69
The Workshop	71
Fire Resistance.....	72
Building Below Grade	73
Chapter 7: Conclusion	76
Appendix 1: Ground Floor Plan	77
Appendix 2: Second Floor Plan.....	78
Appendix 3: Material Investigation.....	79
Appendix 4: Final Defence Pin-Up	80
References	81

List of Figures

Figure 1: Hemp shivs in 33 lbs bag (Lincolnshire Lime 2020).....	2
Figure 2: Hempcrete block home under construction using structural blocks. (JustBio Fibre Structural Solutions 2017).....	2
Figure 3: Industrial hemp field approximately half way into its growing cycle. (Rodale Institute 2020).....	2
Figure 4: View of the rock gardens from the entrance area of the proposed Hemp Research Centre. The garden contains 450 tons of red granite. (Dalhousie University 2020)	4
Figure 5: This site plan is the proposed concept for the Hemp Research Centre located in the Agricultural Campus at Dalhousie University in Truro, Nova Scotia.	5
Figure 6: Site constraint.....	6
Figure 7: Social gathering.....	6
Figure 8: Site drainage	6
Figure 9: Site vegetation.....	6
Figure 10: HempWool insulation installed in a roof joist (Hempitecture 2020a).....	6
Figure 11: Training session for students and contractors to become qualified to install hempcrete. (Hempitecture 2020b).....	7
Figure 12: Wall assembly using 6” pre-cast hempcrete blocks with lime mortar, servicing conduit then filled with 8” hempcrete wall fill, vertical wood strapping, breathable building wrap, finished with horizontal wood cladding.	8
Figure 13: Hempcrete filled wall with 2x4 stud framing.	9
Figure 14: Carbon sequestration	11
Figure 15: Global domestic extraction in 2017, by material group. (Vienna 2019)....	12
Figure 16: Quarry and mining processes to collect the components that make up cement. (Lion Bulk Handling 2020)	13
Figure 17: Carbon impacts of concrete. The process involved in producing the necessary ingredients for concrete has several occurrences when CO ₂ is introduced into the environment (Architecture 2030 2019)	14
Figure 18: Carbon impacts of wood. Most wood products are disposed of at the end of the building’s life, at which point any stored CO ₂ is released through decomposition. Some wood members can be recycled or reused. (Architecture 2030 2018b) .	16
Figure 19: Carbon impacts of insulation. Comparing sustainable insulators to non-sustainable insulators in regards to carbon contribution into the atmosphere. (Architecture 2030 2020b)	18
Figure 20: Insulation comparisons for embodied carbon (King 2017).....	20

Figure 21: GHG emissions balance per m ² of hempcrete wall (Arrigoni et al. 2017)	21
Figure 22: Industrial hemp farm at the Hemptons farming village is Upstate New York.	23
Figure 23: There is clear evidence as to why Sativa is the favourable plant for Industrial hemp between the three species. (McPartland 2018)	23
Figure 24: Industrial hemp supply chain	26
Figure 25: The image on the left is of a farmer separating the fibre from the woody core of the hemp plant using a tool that breaks the wood keeping the fibre strands intact. (Astre 2018). The image on the right is the modern-day version called a decodification machine that separates the two parts and bundles them into bales for use later. (Hemp Inc 2015).	27
Figure 26: Hemp cultivation process from cradle-to-site	28
Figure 27: Average Canadian rain fall and temperature graph based on table (Current Results Publishing LTD 2017)	30
Figure 28: Graphic representation of the wall, roof and floor assemblies existing today. Recreated from (Evrard 2006)	31
Figure 29: Self conducted testing.	32
Figure 30: R-values for different thickness of walls from two different projects.	33
Comparison of density related to the wall thickness, showing how thermal value is effected depending on the density of the hempcrete mixture (Dhakal 2017).	33
Figure 31: Thermal mass study	34
Figure 32: Isotherms in the wall corner in the two cases of timber frame location: A) central, B) aligned with inner plane. Wall thickness 350 mm, hemp-lime conductivity: 0.080 W/(mK) (Grudzińska and Brzyski 2019, 384)	35
Figure 33: Hemp textiles to apply to the acoustic panels (unknown 2020).	35
Figure 34: HempWool Fibre dense fibre insulation (Hempitecture 2020)	36
Figure 35: Hemp husk acoustic paneling (Aotta 2018)	36
Figure 36: Hygroscopic properties - Absorption and movement of moisture. (Hempcrete Natural Building LTD. 2018)	37
Figure 38: JustBio Fibre Block - interlocking structural hempcrete block (JustBio Fibre 2017)	38
Figure 37: Strength (Hempcrete Natural Building LTD. 2020)	38
Figure 39: Hempcrete block home under construction using structural blocks. (JustBio Fibre Structural Solutions 2017)	39
Figure 40: JustBio Fibre Blocks used to create curved walls (JustBio Fibre Structural Solutions 2017)	39
Figure 41: Self conducted fire testing comparing the lime binder ratios.	40

Figure 42: Characteristics of natural lime (Stanwix and Sparrow 2014, 50).....	42
Figure 43: First hempcrete test resulting in mould spores due to moisture in the air and not removing the formwork at the appropriate time.	44
Figure 44: 1:1 Investigation - Hempcrete cast in place	47
Figure 45: This structural frame is set in the middle of the wall to give maximum coverage of 55mm around the frame. This as above the recommended minimum for protection of the structural frame.....	49
Figure 46: Diagram representing option using the cast-in-place method from the least effective to the most effective regarding thermal bridging.	50
Figure 47: Sketch of a hallway interacting with a curved hempcrete wall.	51
Figure 48: “hempcrete infill in a timber frame with the frame visible on both sides (a) Shuttering fixed prior to placing. (b) shuttering removed and hempcrete shaped back adjacent to main timbers. (c) Finishes applied, closed into main timbers.” (recreated from Stanwix and Sparrow 2014, 276)	51
Figure 49: Beveling at the window opening provides a finished look without trimming the window with another material	51
Figure 50: Instaling hempcrete via spray applied (Hempitecture 2019)	52
Figure 51: IsoHemp blocks used for insulation an subbase on the floor as well as the walls.	53
Figure 52: ISOHemp floor detail	54
Figure 53: HempWool (Hempitecture 2019).....	54
Figure 54: Closeup of the fibres in the hemp quilt product. Note the tight fit of the batts into the stud cavity.	55
Figure 55: Non masonry cladding details (recreated from Stanwix and Sparrow 2014, 332)	55
Figure 56: “(A)(B) This wall detail is not a good condition as it allows air leakage between the hempcrete and hemp-quilt insulation.(C) This detail provided adequate sealing between the hempcrete and roof sheathing by sandwiching hemp quilt before installing the sheathing board.” (Stanwix and Sparrow 2014)	56
Figure 57: The airtight junction at the eaves of a flat roof with a warm roof build-up. Exposed hempcrete wall finish and exposed structure. (Stanwix and Sparrow 2014, 326)	57
Figure 58: Three different types of floor finish. A) Limestone slabs, lime mortar bed with in-floor heating, lime-rich hempcrete slab, free drainage aggregate, undisturbed soil. B) Rough sawn wood planks, 2x4 embedded, lime-rich hempcrete slab, free drainage aggregate, undisturbed soil. C) Polished lime floor slab with in-floor heating, lime-rich hempcrete slab, free drainage aggregate, undisturbed soil.	58
Figure 59: A multi-tool is useful for carving and shaping hempcrete. (Stanwix and Sparrow 2014, 106)	59

Figure 60: A selection of tubs and buckets is essential throughout the build. (Stanwix and Sparrow 2014, 106)	60
Figure 61: Grid, sponge, and nail floats: used for finishing planter and shaping hempcrete (Stanwix and Sparrow 2014, 107)	60
Figure 62: A large pan mixer is ideal for mixing hempcrete. (Stanwix and Sparrow 2014, 105)	60
Figure 63: Hempcrete can be shaped with a nail or grid float after casting (Stanwix and Sparrow 2014, 188)	61
Figure 64: Inhabited Section: This is a section through the proposed Hemp Research Center at Dalhousie University in Truro, Nova Scotia. From left to right entering into the Hems Cafe, then on the main level is the auditorium, labs, and workshop. Upstairs in the student lounge, studio space and workshop mezzanine.....	63
Figure 65: The Hemp Cafe is a double-height space connecting the public Cafe and shop with the student lounge area.....	64
Figure 66: Student Lounge - a combination of exposed hempcrete and plastered walls create a space of warmth and comfort for relaxing and studying. The selection of walls or ceilings for exposed hempcrete is based on those with minimal risk of damage, balancing the overall space.	65
Figure 67: Site drainage section - grading the surrounding on the building to reduce the risk of moisture infiltration is critical for a hempcrete building. Especially on the north-face as it has less sun to promote drying.....	67
Figure 68: The textiles lab in the Hemp Research Centre is where textile testing, development and innovation would take place.	68
Figure 69: Combining ideas form concrete design by creating more elaborate form-work to create designs and patterns in the exposed hempcrete walls.	68
Figure 70: Fabrication of accoustic panels	69
Figure 71: Hempcrete application against existing or new brick. This method is used for the demising wall between the extention engineering and the Hemp Research Centre. (ISOHemp 2020).....	69
Figure 72: The shared demising wall between two buildings - In this section, the hemp textile lab shares a wall with an engineering lab. Offsetting the height of the new building allows sunlight to enter into the studio space.	70
Figure 73: Grass roof - Using recycled metal to produce standing seam roofs to get a substrate to install a grass roof. This helps the building fit into the existing agricultural campus context, contrasting against the rock garden.	71
Figure 74: Cross Section relationship between the workshop and the existing greenhouse. The profile of the roof allows the sun full access to the green house year around.	72

Figure 75: This illustration is proposing to fire rate columns using hempcrete similar to steel cast into concrete with the hopes of reducing the need for old-growth trees. Any laminated lumber would need to be fastened using galvanized fasteners to prevent rusting. 72

Figure 76: This section illustrates how to use hempcrete in an underground situation when moisture is a concern. The use of hemp block, among other reasons, is beneficial as it's installed with the moisture content already removed, reducing the risk of mould during its install/curing time. The use of the welded wire mesh and site gathered stone minimizes the use of concrete. 74

Abstract

Industrial hemp is grown from the plant Cannabis Sativa and is used in a variety of industrial and consumer products worldwide. It can grow very tall, very fast, with little to no fertilizers or pesticides. The design goal is to provide space where manufacturing, testing and experiencing can all take place — creating a feedback loop for new ideas—finding new ways to capitalize on the superior characteristics of hempcrete. This thesis looks at the components of hempcrete, whether for the wall, floor or roof. The higher the compaction, the lower the thermal value. The looser it is packed, the better the thermal value. Looking at these characteristics to help understand the value hemp can provide, proposing new hybrid wall assemblies that capitalize on these characteristics. The building intends to be a space where users can connect, learn, and build providing feedback for all things hemp.

Acknowledgements

I would first like to thank my thesis supervisor Dr. Ted Cavanagh of Dalhousie's School of Architecture. He was always available whenever I had a question about my research or writing. He consistently allowed this paper to be my own work but steered me in the right direction whenever he thought I needed it.

I would also like to thank my advisor, Professor Cristina Verissimo, who was involved in the validation of this research project. Without her passionate participation and input, the validation could not have been successful.

I would also like to acknowledge my sister Sara Rodrigues as the second reader of this thesis. I am gratefully indebted to her for her valuable comments and support.

Finally, I must express my very profound gratitude to my wife and my parents for providing me with unfailing support and continuous encouragement throughout my years of study and through the process of researching and writing this thesis. This accomplishment would not have been possible without them. Thank you.

Chapter 1: Introduction

Reducing CO₂ emission through the sequestration of carbon in natural fibre has been gaining traction as a suitable way to solve our global carbon crisis. Building materials currently use many suitable natural fibres; however, this thesis focuses on the fibres and by-product of the hemp plant. The hemp plant has many uses, with medical and recreational drug use being the most recognizable. This report focuses on the industrial hemp plant, Cannabis Sativa, and its use in the built environment. This type of hemp is a fast-growing erect yearly plant that produces few branches, generally at the top 1.5m. Typically Sativa grows to heights anywhere from 3m up to 7.5m with a stem diameter of approximately 13mm to 25mm. Hemp has been used worldwide for centuries to produce a variety of industrial and consumer products.

Historical Use of Hemp Apart from Building Materials

Cannabis Sativa is one of the earliest documented domestically grown plants, with evidence of its cultivation by people 12,000 years ago (Stanwix and Sparrow 2014, 16). It is found across the world and used for a range of essential goods used in a wide range of products including the seeds for foods, oils, and cosmetics; the fibre for rope, fabric, sailcloth, papers, and more recently, the hurd for animal bedding, fiberboard, and hempcrete.

Hemp as a Building Material

The hemp plant is made up of three parts, the seed, fibre, and hurd, or also known as the shiv. When we discuss using hemp as a building material, we are focusing on the hurd, which is the woody core of the plant. Other applications use



Figure 1: Hemp shivs in 33 lbs bag (Lincolnshire Lime 2020)

the fibre, and we will touch on that later in this report. The inner woody stem, the hurd or shiv, historically has been the least valued part of the plant typically being spread on the field or burned as a biomass fuel. This part of the plant is now being used more frequently for purposes such as animal bedding, packaging and Hempcrete. Figure 1 is a bag of hemp hurd one would purchase to combine with other ingredients to make hempcrete. Later on, in Chapter 3 there will be a full breakdown of the uses recorded worldwide today.



Figure 2: Hempcrete block home under construction using structural blocks. (JustBio Fibre Structural Solutions 2017)

Hempcrete is a common term for hemp-lime; this is a composite material created by mixing the hemp hurd with water and a lime-based binder. This combination gets cast into moulds, not unlike cast-in-place concrete or precast. As this material gains popularity, more methods are becoming available, with the most popular being loose-fill hempcrete, pre-made blocks, and pre-made panels. Each method has its own set of advantages and disadvantages. In Chapter 5, we will give a breakdown of each method and discuss how to appropriately apply them based on their characteristics.



Figure 3: Industrial hemp field approximately half way into its growing cycle. (Rodale Institute 2020)

Why Growing Hemp is so Important

Due to the rapid growth of hemp, it can sequester far more CO₂ than other building materials. The growing cycle of a hemp plant is short, taking only 3 to 4 months to mature. In comparison to the material from a cut down tree that can take an average of 50-100 years to grow, requires transportation to get to the mills, then fossil fuels to prepare, trim and process logs into usable building materials. Not only does hemp sequester more CO₂, but it can also be a dual crop, meaning, while a farmer may be growing hemp for seeds for the food industry, they can also process the leftover plant and separate the fibre from the hurd, selling both parts of the plant. Practically none of the plant goes to waste and, therefore, no sequestered CO₂ is released back into the atmosphere.

Growing Climate for Hemp

Hemp is grown all over the world; however, the focus of this report looks at the Canadian climate, specifically Truro, Nova Scotia, as a viable agricultural hub for hemp in Atlantic Canada. Truro is known for its agricultural development housing Dalhousie's Agricultural Campus since 2012, originally founded as the Nova Scotia Agricultural College within the NS Department of Agriculture.

Hemp requires a pH level of 6 or higher, which means it is able to grow in a high alkaline environment. Dalhousie has several suitable field plots that would make for ideal growing conditions, either on its own or seasonally paired with another plant. Paired growing can be done by growing an early spring plant, then once completed, plant hemp to finish off the season. This is only possible because of the short cultivation period. In some tropical climates, farmers

can grow as many as three cycles on the same plot for one year.

The Site

As briefly mentioned above, this selected site is part of the Agriculture campus, overlooking the rock gardens behind the central heating plant (refer to Figure 5). Currently, an access road runs between the back of the heating plant and the campus rock garden where the horticulture department exists. The Extension Engineering Building and Heating Plant initially housed all of the campus Engineering initiatives, including shops, a classroom, and offices. A wood chip boiler and chip storage bin was added in 1988 to the central heating plant (Dalhousie University n.d.). This area also contains the Collins Building, where the faculty and staff of the Environmental Sciences Department and the Environmental Horticulture program are located. There is also equipment and facilities for outdoor activities and grounds maintenance for the 'Friends of the Garden' group, who maintain the rock garden. The building received its name after Charles McKittrick Collins, who taught horticulture for

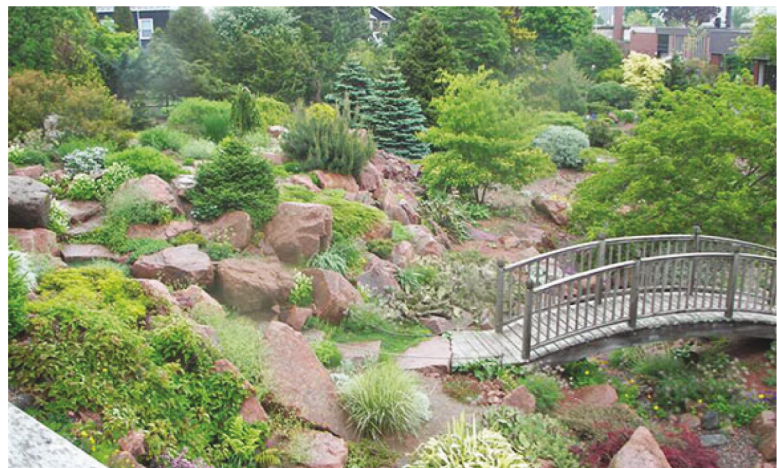

Figure 4: View of the rock gardens from the entrance area of the proposed Hemp Research Centre. The garden contains 450 tons of red granite. (Dalhousie University 2020)

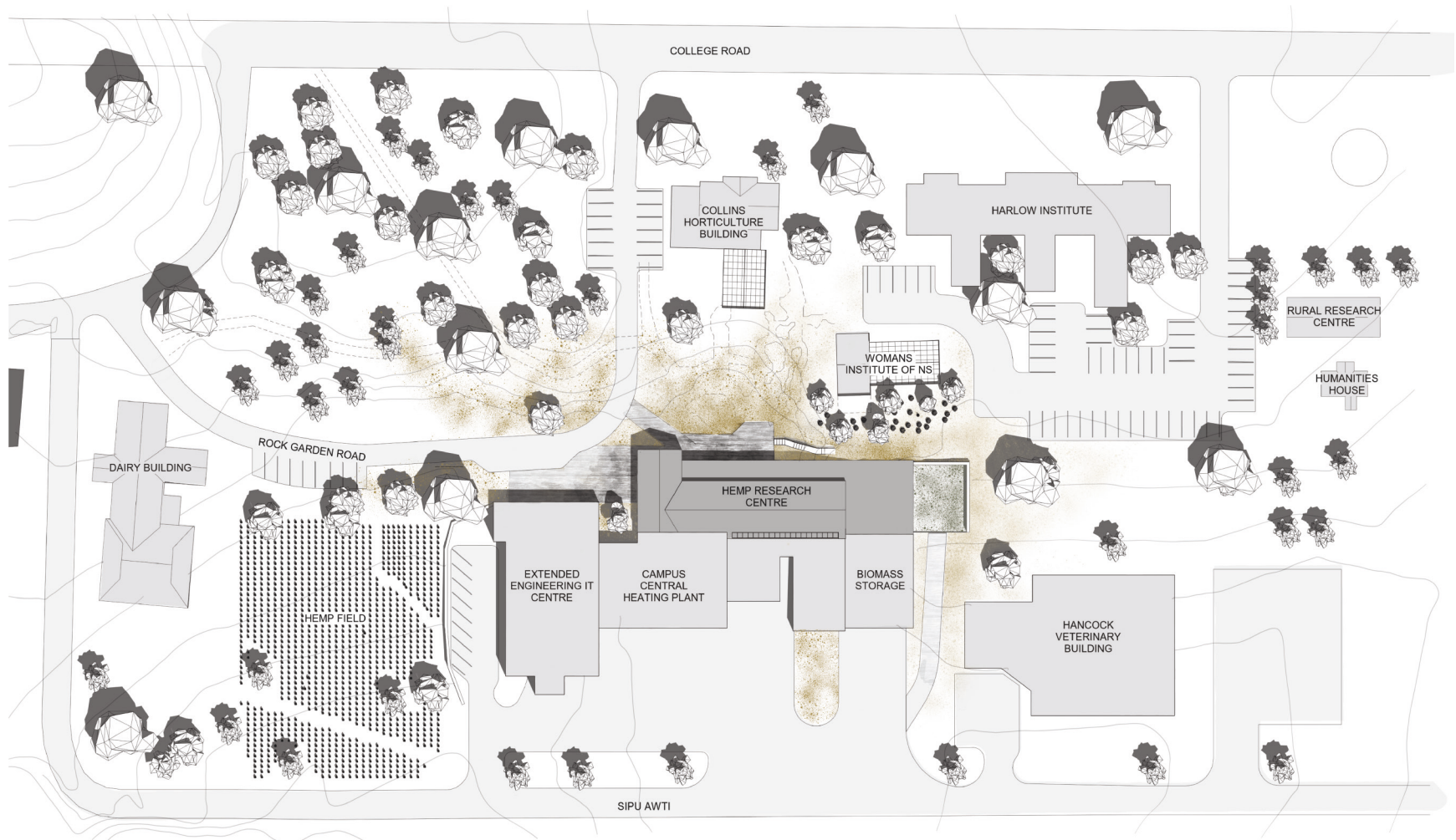

Figure 5: This site plan is the proposed concept for the Hemp Research Centre located in the Agricultural Campus at Dalhousie University in Truro, Nova Scotia.



Figure 6: Site constraint



Figure 7: Social gathering



Figure 8: Site drainage



Figure 9: Site vegetation

25 years at this school (Dalhousie University n.d.). The rock garden contains several paths and seating areas for students to enjoy between classes. However, the Heating Plant takes away from this enjoyable space.

Several considerations went into the decision when selecting this area. User accessibility, view and general location within the campus are inherent, but when considering hemp as a building material, drainage and site constraints are also an essential factor.

Connecting People to Hemp

This report intends to be a proof of concept for a design tailored explicitly to hemp. The proposal is for Dalhousie's first Hemp Research Centre situated in the heart of the Dalhousie agricultural campus. Allowing people to experience hemp firsthand is incredibly significant. Testing how we interact with hemp through the haptic qualities is paramount to understanding the advantages of hemp beyond its ability to keep us warm and safe. Touch- Light



Figure 10: HempWool insulation installed in a roof joist (Hempitecture 2020a)

– Comfort, are all words that come to mind when imagining how a hemp building can make us feel.

Students will be able to test the benefits of hemp in a judgment-free space. A space where they can relax, catch up with friends, enjoy snacks, study or find valuable information on hemp. A set of skilled and experienced Cannabarista's will be there to serve. The Hems Cafe will host a fully functioning greenhouse where one can sit and experience the horticultural aspects of the campus while lounging on the hemp made furniture, designed and made by students. Hemp food and drink or hemp boutique products would be available for purchase. The Hems Cafe aims to showcase materials and products developed on campus from the students, as well as other hemp products on the market today.

Learning About Hemp Through Design

There are various ways a student can learn about hemp throughout the design of the Hemp Research Centre. The acoustic experience in classrooms and the auditorium, or through the workshop and training centre giving students hands-on experience and resources. Alternatively, through the cafe and lounge where students can experience the final product, whether its the furniture, textured walls, or the food and drinks from the Hems Cafe.



Figure 11: Training session for students and contractors to become qualified to install hempcrete. (Hempitecture 2020b)

Experiencing Acoustics

Class auditoriums obtain excellent sound quality typically by changing the shape of the room or using sound absorption panels to help reduce the reverberation. The Hemp Research Centre will house a 70 person auditorium showcasing how hemp can improve a room's sound quality. The combination

of hempcrete and hemp fibre come together; the walls of porous hempcrete combined with hemp made sound panels hung from the ceiling to absorb the reverberation of sound during lectures or performances.

Building Hands-on Experience and Training

Working with hemp relies on the precision and quality of the worker. In order to achieve a quality finish, it is essential to

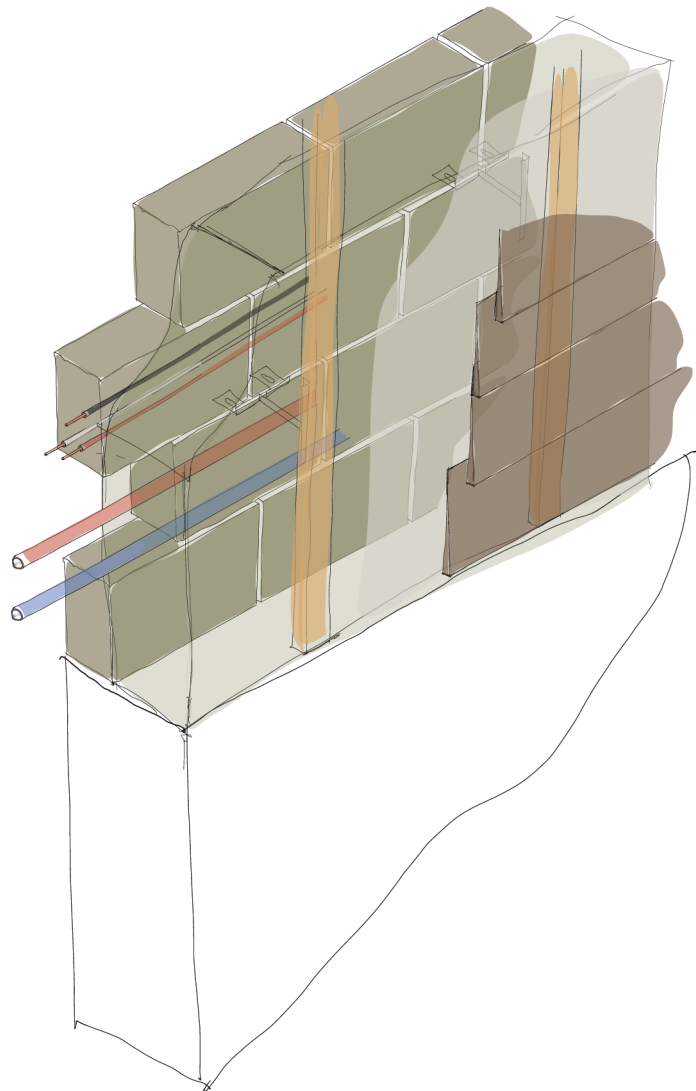

Figure 12: Wall assembly using 6" pre-cast hempcrete blocks with lime mortar, servicing conduit then filled with 8" hempcrete wall fill, vertical wood strapping, breathable building wrap, finished with horizontal wood cladding.

get hands-on with working with the material. It is essential to provide a space where students can test their ideas by building with the material firsthand. Using the hemp grown on campus to build full-scale walls and small builds is crucial. When designing a shop, specific consideration will improve the quality of the space. The workshop is an opportunity to showcase one of the many characteristics of hempcrete, including its ability to be fire-, pest- and mould-resistant. A workshop environment requires a specific fire rating typically higher than other areas of the building. It will also need to take the abuse of everyday work, with large-span space for assembly, as well as space for hanging tools and equipment. As mentioned before, the more we compress hemp, the less thermal value it has, but the stronger it will be. Cast-in-place hempcrete could be delicate to touch

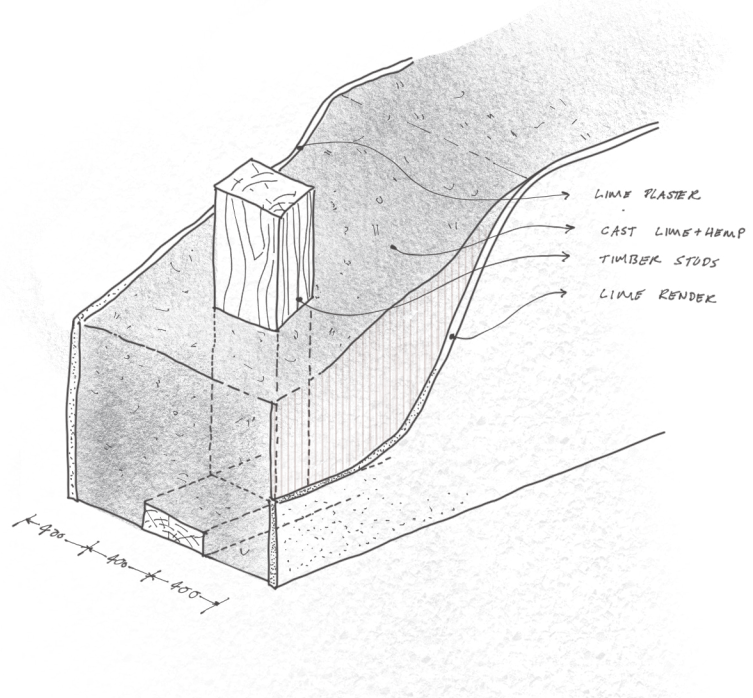

Figure 13: Hempcrete filled wall with 2x4 stud framing.

and would not be the right solution for a workshop unless finished with lime plaster. Increasing the density of hemp does not mean it becomes a load-bearing wall; however, using a hemp block and lime mortar as an interior finish will provide the robust needs of a shop wall while providing a cavity to run electrical and mechanical behind. In figure 12 above shows how we could combine the advantages of each method for a wall assemble that uses hemp block with an on-site cast hempcrete. The interior block wall would act as one side of the formwork for the loose-fill. The drawback to this wall assembly is that it requires a broader footprint as walls can get as thick as 400mm to 600mm depending on the foundation/ footing needs.

Chapter 2: Reducing CO₂ Emissions by Natural Material

The idea of building ‘natural buildings’ is an increasingly popular idea across Canada and the world. Regardless of new build, renovation or restoration, people are moving to this approach of sustainability. This report concentrates on the construction industry’s carbon emissions—specifically on high impact materials and how using hemp can be an alternative to these consequential materials.

Hemp is an excellent crop for carbon sequestration. Like other crops, it collects carbon during its growth cycle. As hemp has several uses, minimal amounts of the produced CO₂ enters back into the atmosphere. If the plant decomposes or burns, the carbon initially collected will enter back into the atmosphere, with some entering into the soil. The longer we can store the embodied carbon in these buildings, the better off our planet is.

Why Embodied Carbon

According to a report conducted for the province of Ontario, “buildings account for nearly one-quarter of Canadian greenhouse gas (GHG) emissions” (Zizzo Strategy 2017, 1), also identifying the reduction of GHGs from the construction sector as a critical component in the global fight against climate change. According to the Carbon Smart Material Palette, more recently, in an annual base, “embodied carbon is accountable for 11% of global GHG emissions and 28% of global building sector emissions” (Architecture 2030 2020a). There is a decrease in the overall carbon emitted into the environment; however, this shift is not happening fast enough. Using natural materials like hemp

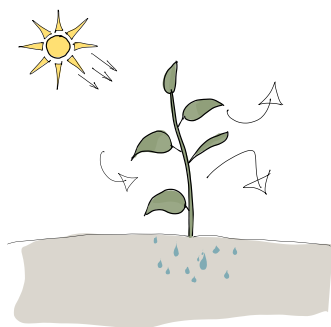

Figure 14: Carbon sequestration



Figure 15: Global domestic extraction in 2017, by material group. (Vienna 2019)

that take little energy to process will help our odds of getting there. One category that is not contributing to the fight to reduce emissions is in the mineral extraction category. This category includes sand gravel and crushed rock for construction, metal ores, and non-metallic minerals. Refer to Figure 15 for the total breakdown of material extracted in 2017. “The extraction of minerals used in the construction sector has increased during the 1900s and more in the early 2000s from 18.8 Gt/y in 2000 to 37.9 Gt/y in 2013”

(Arrigoni et al. 2017). This increase suggests that although we see improvement in some sectors, mineral extraction has doubled in quantity. These sectors are responsible for the use of materials like concrete and steel, which are considered high impact materials.

High Impact Materials

The building industry would benefit by taking steps towards reducing high impact materials. There are responsible ways to use materials like concrete and steel to reduce overall use. The continued use of sand and mineral will continue to deplete the earth's resources. These are resources that cannot be replenished, unlike the agricultural resource discussed later in this chapter.

Concrete

“Concrete is responsible for 6-10% of global anthropogenic carbon dioxide” (Architecture 2030 2019). These are the emissions associated with human activities, which “include the burning of fossil fuels, deforestation, land-use changes, livestock, and fertilization” (University of Calgary 2016). Portland cement is the main ingredient in concrete and is the major contributor to the overall carbon emissions of concrete. CO_2 is released into the atmosphere twice during cement production. In essence, roughly 40% of the CO_2 generated is from the burning of fossil fuels in the manufacturing process, and the remaining 60% is from naturally occurring chemical reactions during processing. (Architecture 2030 2019) Due to its high energy input, it drives the overall carbon emissions of concrete to an unsustainable level. By using less cement, the carbon footprint created by concrete would be significantly reduced.



Figure 16: Quarry and mining processes to collect the components that make up cement. (Lion Bulk Handling 2020)

We should be doing our best to reduce the overall amount of cement in the mixture. For example, using the maximum size aggregate and switching to non-fossil fuel cementitious materials. However, a better solution is not to use these minerals at all in the building sector. One of the main reasons cement is the standard practice is due to its 28-day strength time frame. Other binders exist; however, they require longer curing times, making them less suitable for standard construction methods. By adjusting our construction practices to other supplementary cementitious materials, we could reduce the amount of CO₂ created.

According to the team at Architecture 2030, “Some applications of concrete (e.g. slabs on grade) can be used without steel reinforcement as long as alternative

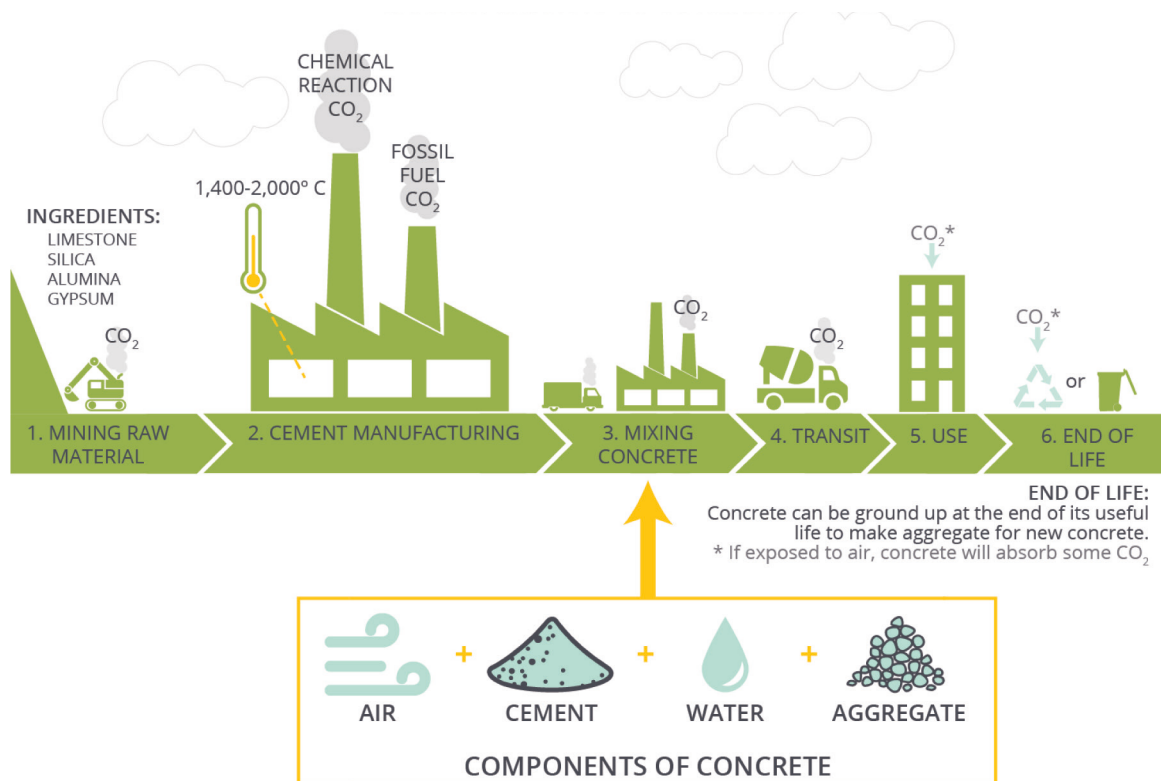

©2019 2030 Inc./Architecture 2030. All Rights Reserved

Figure 17: Carbon impacts of concrete. The process involved in producing the necessary ingredients for concrete has several occurrences when CO₂ is introduced into the environment (Architecture 2030 2019)

crack control measures exist” (Architecture 2030 2018a). Later this report depicts examples of floor systems using hemp and lime; these systems do not require any added reinforcements, which reduces the overall embodied carbon of a floor system. If using concrete is a must, there are alternatives we can add to help reduce the overall embodied carbon, such as “fly ash, slag, calcined clays, or even lower-strength concrete where feasible” (Strain 2017).

If we compare the end-of-life cycle of a concrete building vs. a hempcrete building, the waste is staggering. Not only does the process of breaking and removing concrete use a large amount of diesel, but it also typically ends up in our landfill. Hempcrete during its end-of-life cycle can be broken down and spread on fields to provide nutrients back into the soil, effectively leaving little to no trace behind.

Steel

There are two ways to create steel; basic oxygen furnace (BOF) vs. an electric arc furnace (EAF). BOFs burn coal or natural gas to melt iron-ore during the extraction phase and then mix the iron with recycled iron and steel to make new steel (Architecture 2030 2018a). Steel made using the BOF method is used for structural members. BOFs produce far more CO₂ than EAFs. EAFs only uses recycled content as it does not have the strength to heat up iron-ore the same way BOF's do. “Steel manufactured on EAFs has high levels of recycled content, up to 100%, with an average recycled content of 93% for hot-rolled shapes (Architecture 2030 2018a). The furnace that produces less carbon typically does not produce the steel needed for structural building solutions. Consider using alternatives to steel to hold up the building and use recycled steel to make building materials

such as cladding for walls and roofs. Adjusting how we use these resources will reduce the need for mineral extraction and reduce the overall impact on the environment.

Wood

Unlike the other high impact materials, wood begins by sequestering carbon. “For every kilogram of wood grown, 1.5 kg of CO₂ is removed from the atmosphere and stored” (Architecture 2030 2018b). With sustainable agriculture practices and well-managed forests, the carbon used to cut down the forests would not impact the environment compared to steel or concrete. When forests are not managed well or during global warming concerns, trees are then more at risk.

Moreover, when they have been growing for as long as they are, it is a big hit when a forest burns like ones we have seen in Australia, British Columbia or California every season in our recent history. “If the tree burns during a fire or decomposes from rot, the carbon sequestered in its lifetime

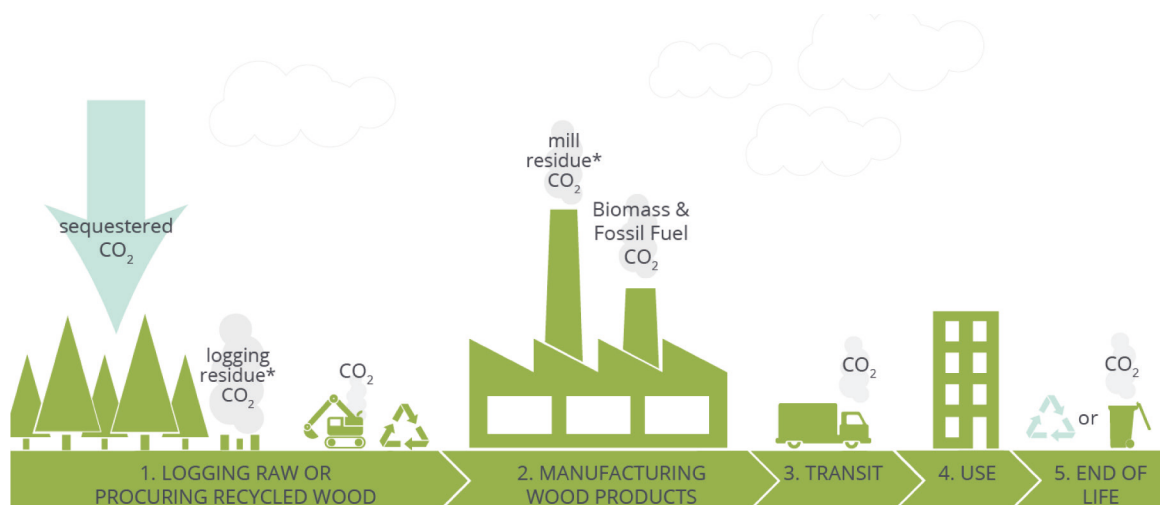

Figure 18: Carbon impacts of wood. Most wood products are disposed of at the end of the building's life, at which point any stored CO₂ is released through decomposition. Some wood members can be recycled or reused. (Architecture 2030 2018b)

enters back into the environment” (Architecture 2030 2018b). This is not ideal when we are trying to sequester and store as much carbon as possible.

With the change in our climate, there is an increasing number of forest fires worldwide, which can be detrimental in reducing our carbon footprint.

Fires blighting New South Wales and Queensland have emitted a combined 306 million tons of carbon dioxide since Aug. 1, which is more than half of Australia’s total greenhouse gas footprint last year, according to Niels Andela, an assistant research scientist at NASA’s Goddard Space Flight Center in Maryland and collaborator with the Global Fire Emissions Database. That compares with the Copernicus Atmosphere Monitoring Service’s estimate of 270 million tons in just over four months. (Lee 2019, 1)

One hectare of industrial hemp can absorb 22 tons of CO₂ (Vosper n.d.) and because it is possible to grow two cycles a year, we can double those numbers. It would be equivalent to growing and storing 6.9 million hectares of hemp to offset the fires’ 306 million tons of carbon. We may not be able to control the number of fires each year, but we can continue to manage the forest sustainably and do our best not to contribute to human started fires.

“About 20% of anthropogenic greenhouse gas emissions are due to deforestation and forest degradation” (Architecture 2030 2018b). Forests must be preserved for the building industry and not for manufacturing products like paper, toilet paper and other pulp-based products. “Global timber harvesting causes us to lose up to 32 million acres (13 million hectares) of forest each year or about 60 acres per minute” (Architecture 2030 2018b). If we save the wood for the building industry and pair it with natural fibre-based material such as hemp, we would sequester more carbon, reduce the use of non-sustainable materials and store the carbon

we are growing in the fields. The longer our building lasts, the longer the stored carbon stays out of our atmosphere. A good practice is to also “specify wood from sustainably managed forests to help ensure that the trees we harvest are replaced, so our forests maintain consistent carbon sequestration” (Architecture 2030 2018b).

Here are a few ways we can help reduce our footprint:

1. Use reclaimed, salvaged or recycled woods to prevent or prolong its carbon re-emissions. Salvaged wood is excellent for formwork and strapping.

2. Look at using fast-growing trees rather than slow-growing.

There are many ways to reduce CO₂ emissions when building with wood. It is impossible to eliminate the use of

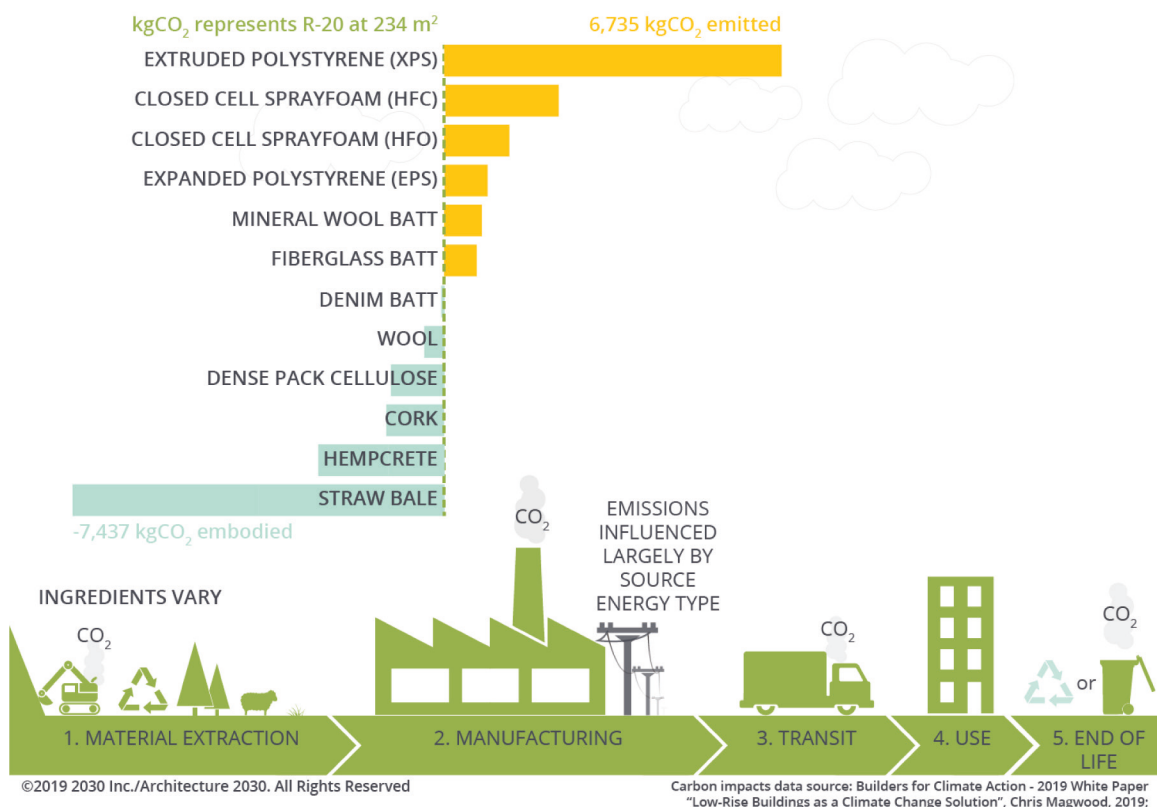

Figure 19: Carbon impacts of insulation. Comparing sustainable insulators to non-sustainable insulators in regards to carbon contribution into the atmosphere. (Architecture 2030 2020b)

CO₂ in the built environment, but we can choose materials and processes that will counterbalance the use of the CO₂ we are using by finding alternatives for the same application. For example, using oriented strand board (OSB) sheathing and plywood as they have comparable characteristics. However, OSB has about double the carbon footprint of plywood sheathing (Kestner, Goupil and Lorenz 2010). Engineered wood products such as Laminated Veneer Lumber (LVL) and Parallel Strand Lumber (PSL) have a more considerable embodied carbon impact than Sawn Lumber, even accounting for their higher strength (Kestner, Goupil and Lorenz 2010). It is essential to find ways to sequester carbon by storing it in materials permanently. Figure 19 demonstrates from left to right that the more energy we input, the more CO₂ the product uses. Using local woods and processing will help reduce CO₂ emissions and support local communities and the labour force.

Insulation

There is a comprehensive set of options for insulating a building, each intended to suit specific situations, whether it is to maximize thermal performance or to meet code while dealing with high moisture content. Two considerations when selecting the right insulation is the embodied carbon and operational carbon. As per Figure 19, extruded polystyrene (XPS) is on the top of the list regarding the amount of carbon it emits, and it is one of the most popular insulating material used in North America. Its popularity is primarily due to its performance when introduced to moisture. XPS is a petroleum-based product that requires a significant amount of energy to manufacture. The alternative low carbon options like hempcrete or straw will store more carbon than it emitted. These insulating options can achieve this because as the

Insulation Material	Embodied Carbon (by Weight) kgCO ₂ e/kg	Embodied carbon for 4x8-foot wall @ R-28 KgCo ₂ e	CO ₂ e sequestered (-) or emitted (+) for 4x8-foot wall @ R-28, kg per panel
Hempcrete	0.1442	45	-87
Straw bales	0.063	22	-78
Cork	0.019	13	-46
Dense pack Cellulose	0.63	41	-19
Denim batt	1.5	22	+2.6
Fiberglass batt	1.35	18	+18
Mineral wool batt	1.28	22	+22
Expanded polystyrene foam	3.29	37	+37
Extruded polystyrene foam	3.42	39	+39

Figure 20: Insulation comparisons for embodied carbon (King 2017).

fibre-based insulations are growing, they are collecting carbon and storing it inside the plant (some gets transferred into the soil). When it is time to manufacture these types of insulations, they take less energy and resources to process.

Avoiding the use of rigid insulations and spray foams where possible reduces carbon emissions, this is not possible in all climates. In some climates, rigid insulation is required for dew point (condensation) considerations. However, some recent projects in marine climates have successfully utilized mineral wool instead of rigid insulation. (Architecture 2030 2020c)

Natural Alternatives in the Built Environment

With smart design planning, we can eliminate the use of positive carbon materials in the built environment by using fibres like straw-bale, bamboo, or hemp.

Straw-bale

Straw-bale construction is a building method that typically uses straw from rice, wheat, rye and oats (Architecture 2030 2020d). Using the stalk or biomass of these grain crops as a construction material has many advantages. One of the most fundamental advantages is its ability to sequester

carbon. “Straw stores sixty times more carbon than it takes to grow, bale, and transport. It is approximately 40% carbon by weight” (Architecture 2030 2020d). These characteristics suggest that straw, similar to hemp, would make an excellent building material as the biomass of these grains is currently not being stored.

Bamboo

Bamboo, like hemp, is a rapidly renewable, and versatile building material. Several different products exist today using this tree-like woody grass plant. Its characteristics make it suitable for flooring, cladding, structural elements and the list goes on.

Unlike timber forests, only 20-25% of the stalk is harvested in sustainable bamboo forests each year (compared to 80-90% of trees harvested in sustainably managed timber forests), and the bamboo plants do not die after harvesting, ensuring no deforestation. (Architecture 2030 2020b)

Hemp/Hempcrete

Hemp is one of the most versatile crops in the world. Hempcrete can adapt to different situations by merely adjusting the binder and ratio of the mix. For example, when combining with lime in a wood frame wall, hemp gets encapsulated by the lime protecting it from moisture, fire and pest issues, as long as the wall can dry out. Hempcrete

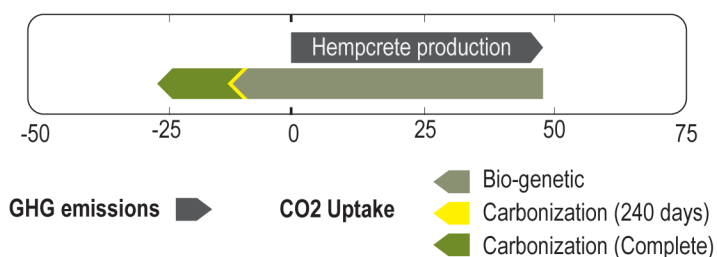

Figure 21: GHG emissions balance per m² of hempcrete wall (Arrigoni et al. 2017)

can also be used in an attic space; in some cases, water is omitted as it is not required. This method is most similar to blown-in insulation. With the right sub-base of drainage, hempcrete can also be used as an insulator and base for a slab on grade, eliminating the need for concrete. This method requires a different application than standard construction practice. Hemp relies on being able to air dry, meaning all these systems mentions must be breathable. Refer to Chapter 5: Hempcrete Construction for more information.

Chapter 3: Hemp Cultivation

Cannabis Varieties



Figure 22: Industrial hemp farm at the Hemptons farming village is Upstate New York.

There are three varieties of the cannabis plant that exist today: Cannabis Sativa, Cannabis Indica, and Cannabis Ruderalis (Stanwix and Sparrow 2014, 15). Both Sativa and Indica have their similarity with Ruderalis being different and much less known. The Sativa and Indica plant rely on the annual season for growth and the Ruderalis plant flowers after a predetermined number of days (Stanwix and Sparrow 2014, 15). The Indica strain grows short and horizontal, which results in a bushy plant, unlike its sister plant. Sativa is the plant this report focuses on, as it is used worldwide as what is known as Industrial Hemp.

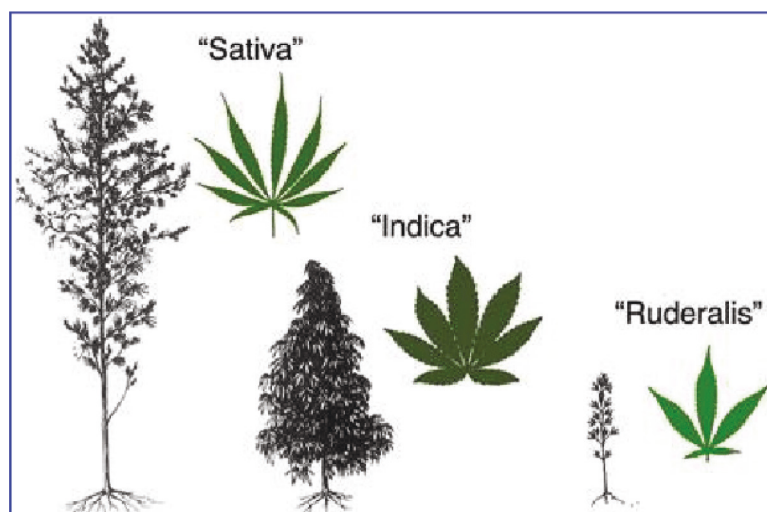

Figure 23: There is clear evidence as to why Sativa is the favourable plant for Industrial hemp between the three species. (McPartland 2018)

Industrial Hemp is any cannabis plant (typically Sativa) that has less than the legal limit of Tetrahydrocannabinol (THC). In Canada, that limit is 3%. Although there are also Sativa plants with more than 3% THC, those fall under the drug regulations for cannabis use and would be illegal to

grow as Industrial Hemp in Canada. Hemp does not require very much to flourish. With a pH of 6, hemp can be paired with many other plants. Locating research and educational facility in the Dalhousie agricultural campus made a good fit; the support of a larger institution is critical for the success and growth of this topic in Canada. Dalhousie has several departments related to horticulture and is continuously exploring agriculture, however, hemp is not currently being studied. One of the interests here is to look at dual crop farming and paired farming with some of the other crops Dalhousie is already growing every year. Currently, there are 9 zones in the Truro area that Dalhousie manages. Of the 9 fielded areas, 6 have suitable pH levels to grow hemp successfully.

History of Growing Hemp in Canada

Hemp in Canada has had a long history; however, only in the last 20 years has it been legal to grow, export and sell industrial hemp. “Industrial Hemp has been permitted in Canada since 1998 and is currently regulated by Health Canada under the cannabis act” (Government of Canada 2019).

Not just anyone can start growing hemp in their back yard. It requires significant regulation, especially around the type of seeds and where those seeds originated. Because of these restriction, only a handful of farmers take this on. According to Health Canada, in 2019, there were only 52 approved cultivars for the industrial hemp variety for commercial production. “A holder of a license that authorizes cultivation, other than as a plant breeder, must only sow the seed of pedigreed status that is of an approved cultivar” (Government

of Canada 2020, 11). Of the 52 approved cultivars, only 32 of them operate in Canada.

Hemp Cultivation

Grow

Hemp can be grown on a small or large scale. The focus of this report is on a small scale cultivation process. Hemp is best grown at a high density, approximately 400,000 plants per acre, and we do not need massive farms to make a dent in the efforts to sequester carbon. If anything, small scale local farming practices are far more sustainable and better for the economy, then industrial size farming practice. In this case, we would be better off spreading out smaller farms across Canada to reduce the transportation cost on the finish side. If hemp required a mass amount of processing equipment, this might not have been the case. However, because cultivating uses traditional farming equipment, it is straightforward to adopt. There is an opportunity to grow other crops either before or after the same season. Hemp grown from seed only takes about 3-4 months to fully mature and go through its dew retting process. 80-85% of the stalk is the hurd while the remaining 15-20% makes up the fibre. This amounts to 6000 lbs of fibre per acre with best practices (Lancaster 2020). Farms like the Hemptons farming village in Upstate New York, dedicate their time to carbon farming to educate and encourage others to farm to sequester carbon.

Process

Once the crop is fully grown, it is ready to be processed, either by hand or by using farm equipment. Farmers separate the flower from the stalk. The stalk will remain on the field

for dew retting. This process encourages a microbial separation of the fibre from the hurd (Lancaster 2020). Retting is a process where the plant starts its decomposing

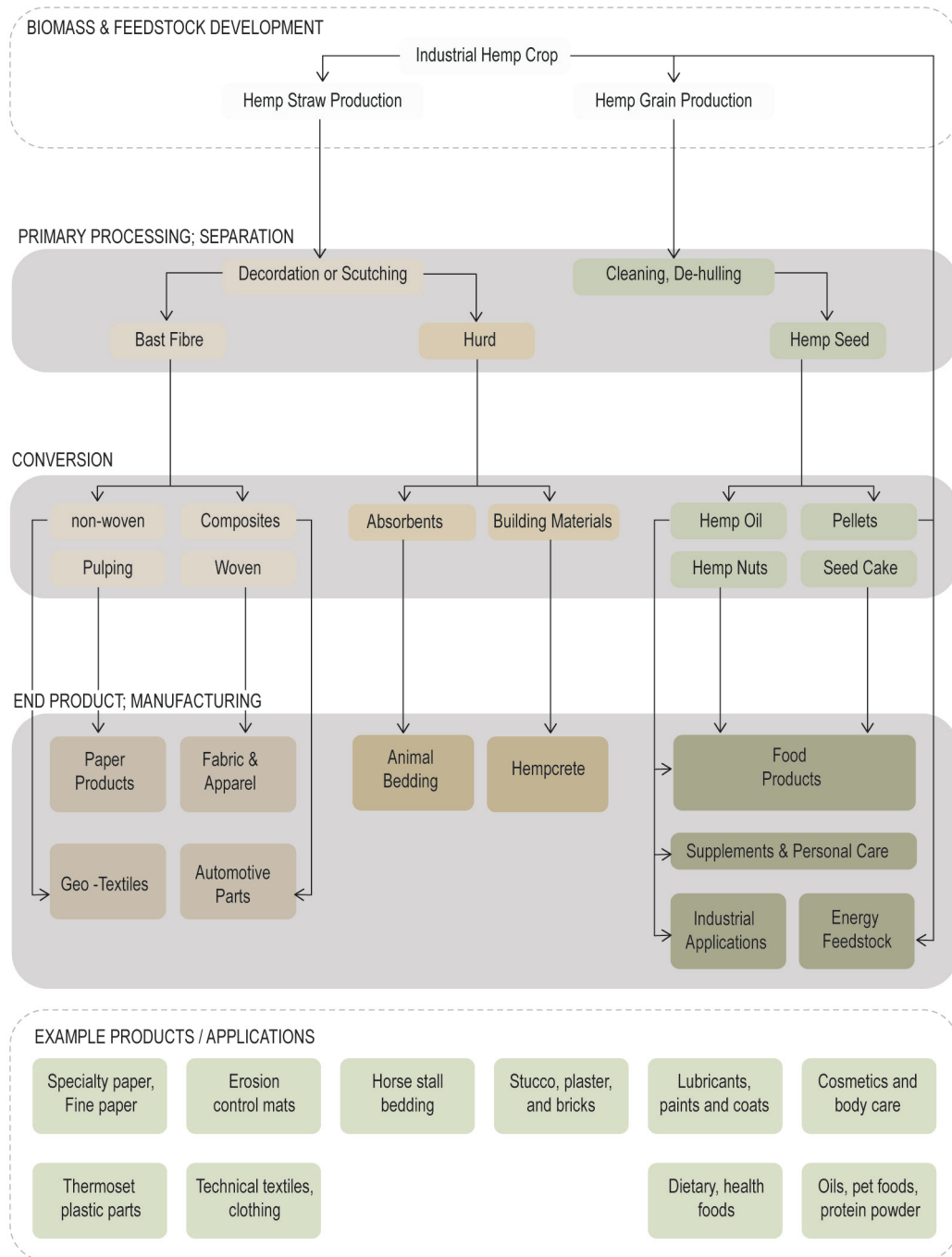

Figure 24: Industrial hemp supply chain

stage only enough to separate the fibre from the woody core, allowing the fibre to separate easily, allowing the fibre strands to be as long as 5 meters. Traditionally farmers would use handmade equipment to crush the woody core leaving behind the fibre fully intact, but as modernization develops, equipment has been designed to detach the two. Decordification equipment, similar to image figure 25 below, allows this process to take place.



Figure 25: The image on the left is of a farmer separating the fibre from the woody core of the hemp plant using a tool that breaks the wood keeping the fibre strands intact. (Astre 2018). The image on the right is the modern-day version called a decordification machine that separates the two parts and bundles them into bales for use later. (Hemp Inc 2015).

Hemp is responsible for several different products. Depending on its intended product, the plant can be grown for its seed, hurd or fibre. For farms growing many acres at a time, larger equipment would be beneficial. Decordification facilities (machine to separate hemp into its components) is a series of rollers in a line double-stacked that spin at different speeds. This process separates the fibre and leaves behind the already mulched hurd.

Farming Tools and Equipment

Cutting and gathering industrially in the fields uses a similar system to straw or flax. In most cases, farmers are using the same equipment, but, in some cases, when the volume

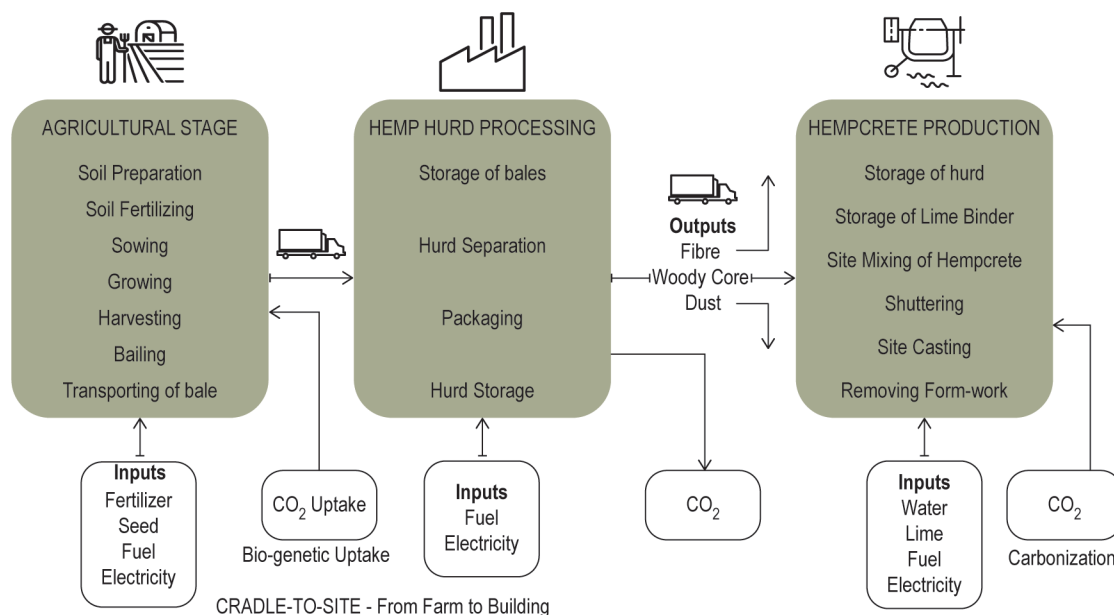

Figure 26: Hemp cultivation process from cradle-to-site

is high, farmers are investing in hemp specific equipment. Typically, farmers tailored to cannabidiol (CBD) harvesting as it requires specific attention. As the industry gains popularity, larger company's like John Deere are launching equipment like the John Deere T660i Double Cutter. As mentioned before, the hemp stalk grows approximately 5.5-7.5 meters tall. This harvester cuts and separates the top 2 meters which contains the flower and seed. Then during the same pass, it cuts the stock and lays it down in the fields to start its retting process. In most cases, industrial hemp is grown for the purpose of food, CBD oils, etc. and is not typically grown for the sole purpose of the hurd. Hurd is often the biomass or leftover of the plant with a low value associated.

Social Impact

The social impact of growing, manufacturing, and production in a small scale allows for a close relationship between the farmer and contractor working with hempcrete. Due to the

fast nature of the hemp growing cycle, it is possible to design a building while the hemp is growing, and build using that hemp within the same year. It brings a new meaning to the idea of design-build. Companies like Hempitecture based out of Idaho United States specialize in hemp construction, design and training. Teams like these allow communities to change the way the building industry looks at materials. This suggestion would only be feasible in a small-scale application where community involvement would be necessary—engaging the community to encourage building with hemp as a way to provide structure for those who may not be able to afford it otherwise. “Where hemp meets hospitality” as a carbon focused farming village can provide farming tours and education. While also producing hemp cosmetics as a way to use some of their growing plants (Villanova and Eckhart 2019).

Chapter 4: Hempcrete Characteristics

Hempcrete can have a wide range of traits due to the nature of the material. I've selected a specific project and company to compare the climatic responses of their buildings as they relate to Truro, Nova Scotia. Hempcrete Natural Building LTD. is a company based out of Bowen Island British Columbia that specializes in modular hempcrete homes and cottages. The company currently has a few buildings situated on Bowen Island and also ships modular homes to other parts of Canada. Climatically Truro, Nova scotia

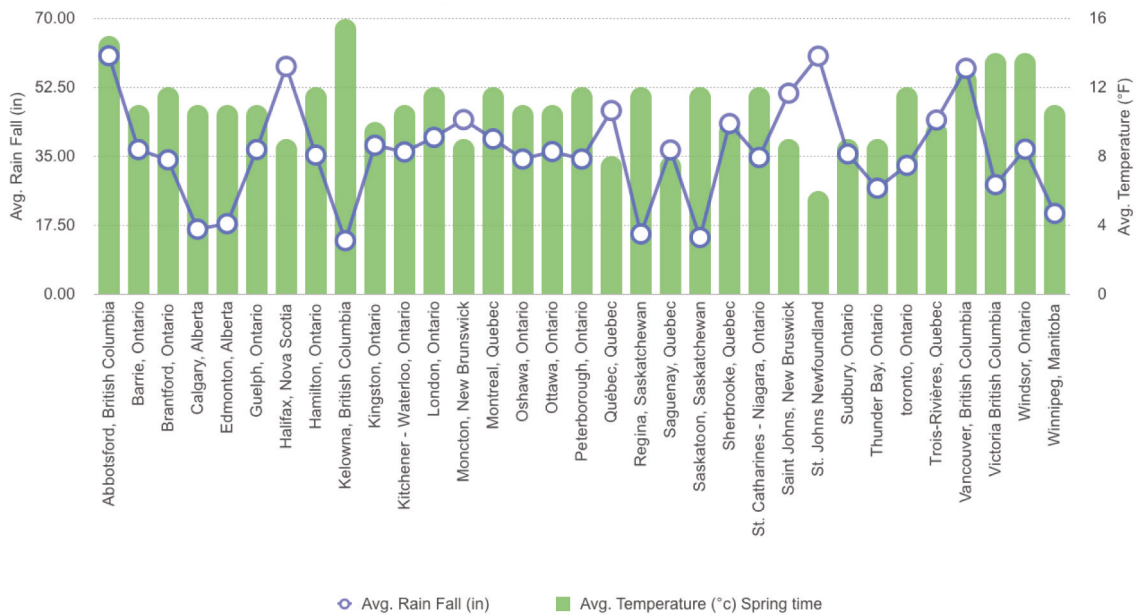

Figure 27: Average Canadian rain fall and temperature graph based on table (Current Results Publishing LTD 2017)

compares closely to Bowen Island, based on weather data collected from Current Results.

For this comparison, the data selected from figure 27 is from Vancouver and Halifax. The average rainfall in Vancouver is 57.30in compared to Halifax’s 57.80in, which is the nearest

weather station to Truro. Average temperature during the springtime is 13 degrees Celsius in Vancouver compared to 9 degrees Celsius in Halifax, and the number of rain days yearly is 168 in Vancouver compared to 162 days. This data set is essential when we look at how viable hempcrete is as a building material in an Atlantic climate.

Hempcrete has distinct characteristics that allow it to serve different areas of a building. The diagram below represents the several forms hempcrete can take in a building. Chapter

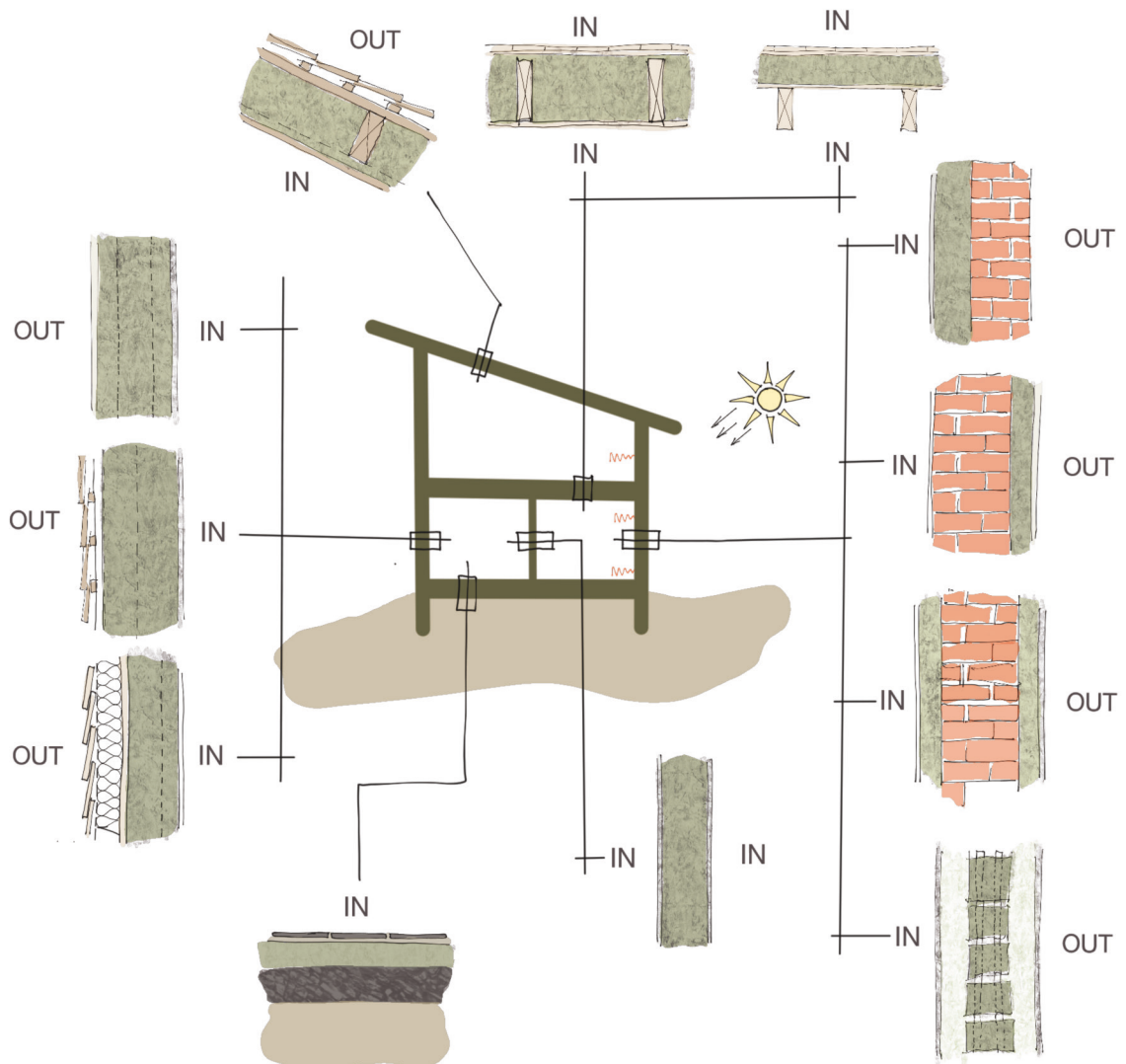

Figure 28: Graphic representation of the wall, roof and floor assemblies existing today. Recreated from (Evrard 2006)

5 includes a breakdown of how specifically each area of the building would get addressed with the focus on stick-frame buildings. Simplified building construction is essential as part of the reason for the report to emphasize how the building industry can grow further while maintaining standard construction practices to promote accessibility and access to the community.

Differences in the Hemp Hurd

Research shows that different amounts of hurd to fibre ratios can affect the overall performance of the hempcrete. Six tests were completed using different fibre-based plants with Hydrated lime to demonstrate the effectiveness of fibre for a strength additive in the mix. Hemp hurd can have a variety of mix in it. UK author William Stanwix recommends the “hemp hurd should be about 10-25mm long and may contain a certain number of fines, but as far as possible



Figure 29: Self conducted testing.

should not contain any dust” (Stanwix and Sparrow 2014). Dust is said to affect the binding process of the lime.

After studying the results in figure 29, the block with 90% fibre and 10% hurd resulted in the strongest. However,

further testing is required to understand the PSI rating and thermal performance.

Thermal Performance

Thermal properties of hempcrete are well-characterized with an increase of studies in recent years publishing performance outcomes for a variety of binder types, densities, moisture contents, and compaction. The numbers can vary a lot in some cases, mainly due to the broad range of construction and application methods. Typically

Wall Thickness (mm)	(Alembic Studio, LLC, 2013)		(Stanwix & Sparrow, 2014)	
	U-Value (W/m2K)	R-Value (m2K/W)	U-Value (W/m2K)	R-Value (m2K/W)
250			0.23	4.35 (R25)
300	0.23	4.35 (25)	0.20	5.00 (R28)
350			0.17	5.88 (R33)
400	0.18	5.56 (R33)	0.15	6.67 (R38)
500	0.14	7.14 (R50)		

(Ahlberg et al,2014)			
Density (kg.m3)	Wall Thickness (mm)	U-Value (W/m2K)	R-Value (m2K/W)
220 kg/m3	300 mm	0.167	6.00 (R34)
	350 mm	0.143	7.00 (R40)
275 kg/m3	300 mm	0.20	5.00 (R28)
	350 mm	0.171	5.85 (R33)
330 kg/m3	300 mm	0.23	4.35 (R25)
	350 mm	0.197	5.08 (R29)

Figure 30: R-values for different thickness of walls from two different projects. Comparison of density related to the wall thickness, showing how thermal value is effected depending on the density of the hempcrete mixture (Dhakal 2017).

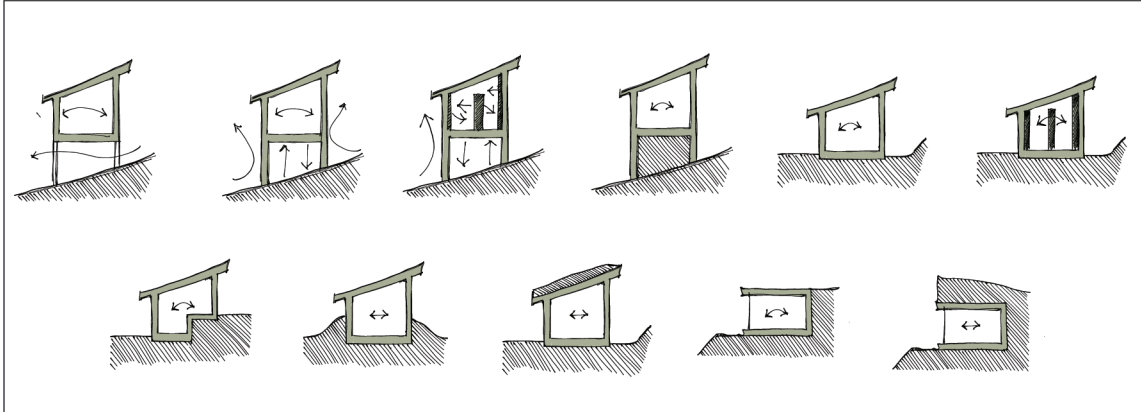

Figure 31: Thermal mass study

hempcrete is unrepresentative of the actual performance when testing for either R or U values, commonly across all studies researched for this report.

According to Hempcrete Natural Building LTD., Hempcrete can range between R2.4 - R4.8 per inch; however, it typically outperforms the stated R-value for a few reasons.

1. Thermal mass – which is its ability to store energy. Modelling and calculating this can pose challenges.
2. Reduced thermal bridging – a standard method of construction is to encapsulate the framing material within the Hempcrete to reduce the number of thermal bridging points.

Thermal Transmittance (U-value)

The Monolithic wall system, by nature, increases the effectiveness of a thermal mass. At a high level, the simple answer is to create formwork that allows the hempcrete to cover the frame. There are challenges to achieving this around the connection points at the floor-to-wall and wall-to-roof conditions. Chapter 5 includes examples how others have achieved this. Figure 32 is a thermal mass study relating to the relationship of hempcrete to ground.

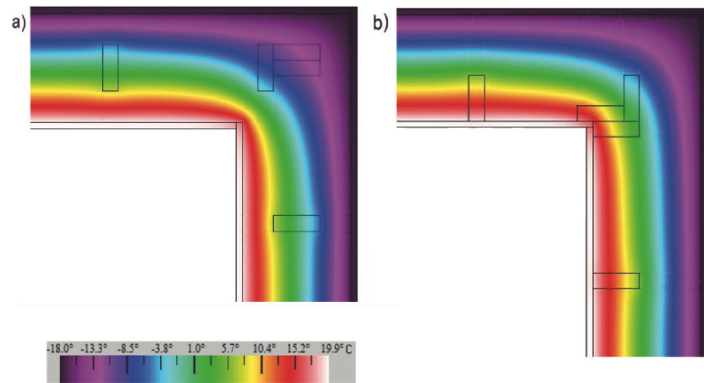

Figure 32: Isotherms in the wall corner in the two cases of timber frame location: A) central, B) aligned with inner plane. Wall thickness 350 mm, hemp-lime conductivity: 0.080 W/(mK) (Grudzińska and Brzyski 2019, 384)



Figure 33: Hemp textiles to apply to the acoustic panels (unknown 2020).

A study conducted by the Lublin University of Technology shows the results of wood framing on the interior on the wall versus the middle. This test is showing how thermal bridging can affect the performance of the wall assembly (Grudzińska and Brzyski 2019).

Sound Absorption

Hemp Acoustic Paneling

Not only can we achieve quality sound from the hempcrete mix, but we can also look at how to use hemp fibre to produce absorption panels. Hemp textiles have been used all over the world from sails to clothing and are considered a durable cloth material. Hemp quilt is a fibre mat material that is reasonably dense and could provide the support for a hemp textile to be wrapped, making acoustic panels. These panels, like others on the market, would be hung in the auditorium or mounted on walls to increase sound quality. The only difference is its made entirely out of hemp, contributing to more long-term carbon sequestration. Other innovative products exist in the market today, like the hemp



Figure 34: HempWool
Fibre dense fibre insulation
(Hempitecture 2020)

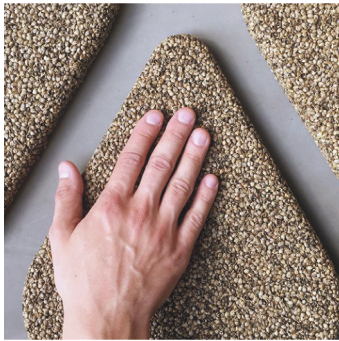

Figure 35: Hemp husk
acoustic paneling (Aotta
2018)

husk sound panels; this consists of using the seed husks after removing the seed for food. Non-toxic glue binds the shells together in moulds to create the desired shape.

Acoustic Environment

The thermal characteristics are the same for acoustic performance. The porosity of the wall allows sound to adsorb into the wall deadening the noise in the space. If we adjust the density of the hemp hurd increasing or decrease the porosity of the wall, we can change the area's sound characteristics. For example, in an auditorium for 70+ people, the acoustic quality is essential. I would recommend exposing the hempcrete on the ceiling instead of keeping the floor structure exposed. This application may make the mixture vulnerable to damage; however, access to it is limited. An added advantage of exposing the hempcrete is the fire rating provided by the lime in the mixture.

Vapour Permeability and Hygroscopicity

Hemp hurd is a naturally vapour-permeable substance, meaning that it allows water vapour to travel through it. "This is due to its porous nature, and its microscopic structure of tiny capillaries created by the cell walls, oriented in the direction of the plant's stem" (Stanwix and Sparrow 2014, 93). Its ability to attract and hold moisture from the surrounding atmosphere, rereleasing it in response to changes in the humidity, allowing a space to feel balanced at all times. Depending on the choice of binder used, the vapour permeability and hygroscopicity will perform differently. "Binders rich in calcium allow a greater degree of vapour permeability and hygroscopicity while those containing hydraulic limes or higher proportions of Portland cement allow less" (Stanwix and Sparrow 2014, 94).

A report presented by Arnaud Evard focusing on the influence of mixing, implementation and water input using a dynamic sorption testing showed how material properties could help in indoor air quality on the recent Nordtest project (Evrard 2006). The report concluded the thermal conductivity experiment demonstrated good performances in both dry and wet states.

Vapor permeability:	3.4 x 10 ⁻⁵ PSI.
Moisture Buffer Value	2 g/(m ² .%RH)
Porosity	80% in volume

Figure 36: Hygroscopic properties - Absorption and movement of moisture. (Hempcrete Natural Building LTD. 2018)

Strength

Cast-in-Place - Racking Strength

Hempcrete's monolithic structure provides not only insulation and a substrate for plaster and cladding but also a great deal of additional rigidity to the structural frame (Stanwick and Sparrow 2014). Traditional wood frame construction typically relies on the sheathing material or diagonal bracing to prevent racking in the building. As hempcrete cures, it solidifies naturally, producing a stone-like result. These results provide the overall wall assembly with additional strength, replacing the need for the plywood or Oriented Strand Board (OSB) sheathing. Data is limited in this area and can be difficult to prove to build officials. Ideally, a building could simply forget about the sheathing and cast the hemp as normal. However, this is not the case. Since hempcrete has a slow cure time, if a builder chooses to continue framing the floors above or roof to stay on schedule,

additional cross-bracing or temporary framing must be installed to prevent movement while the mix is setting. This challenge can increase the complexity of the framing and often increase the timeline. After reviewing several projects, builders tend to approach these challenges in a variety of ways. Depending on the structural requirements, horizontal strapping was installed on the inside of the wall. In other cases, it was mounted on the exterior. Cross-bracing, blocking and metal straps are also used; each of which can effect thermal bridging, sound performance, cost, etc. Depending on the wall's overall goal, there are advantages too, for example, strapping the interior if it's intended to have a wall protection board.

Compressive strength ranges, depending on the casting process;	116 to 145 pounds per square inch (PSI) 29=>1006.56 (0.2 to 6.94 MPa)
Tensile	Composites made of 20% hemp fiber were found to display a tensile strength and modulus of 35 MPa and 4.4 GPa, respectively.
Flexural strength:	44 to 58 PSI Flexural strength: 44 to 58 PSI

Figure 37: Strength (Hempcrete Natural Building LTD. 2020)

Similarly, for the exterior, if the cladding is used, strapping can provide a nailing surface. However, this will increase the thermal bridging and effectively reduce performance. The best solution, although it will add to the cost, is to provide strapping against the main structural studs then encapsulate the entirety of the frame to prevent all thermal bridging points.



Figure 38: JustBio Fibre Block - interlocking structural hempcrete block (JustBio Fibre 2017)

Block

Block Vs. Cast-in-Place

A disadvantage to cast-in-place hempcrete is the time frame at which a project can take. Depending on the workforce



Figure 39: Hempcrete block home under construction using structural blocks. (JustBio Fibre Structural Solutions 2017)



Figure 40: JustBio Fibre Blocks used to create curved walls (JustBio Fibre Structural Solutions 2017)

available, one consideration is to switch to precast blocks. This method could improve the timeline as it eliminates the wait time. Hempcrete blocks are non-load bearing, so the main structure is still required. One possibility is to use the blocks as part of the thermal insulator and as the exterior substrate. This method would get the building weather tight while adding cast-in-place hempcrete to the interior of the assembly to increase the R-value. More on this in Chapter 5: Hempcrete Construction.

JustBio Fibre Block

Load bearing hempcrete block do exist. A Canadian company JustBioFibre has developed a composite hempcrete block. The structural components rely on the internal structure that exists in the hempcrete form. An advantage to products such as this is the approvals that come with it. For example, testing on this product has established a 2-hour fire rating (ASTM E119, CAN/ULC S101 - Fire-Resistance Rating), and tested CAN/ULC-S102 – Flame Spread and Smoke Development with an index equal to 0 (JustBioFibre 2018). These products also claim to have approved load-bearing capacities.

Fire Resistance

The high level of alkaline in the lime binder coats the organic material and provides the fire-resistant. Even the wood frame gets covered in the binder, reducing the risk of burning. Although many jurisdictions have not yet approved this as a viable fireproof product, recent tests show its opportunity. The possibility of this becoming a solution for fire rating on interior partitions, ceiling and roofs depends on a few factors. Like the JustBio Fibre Block, this as a testing product developed to meet specific certifications. As stated

above, this product fits a 2-hour rating. However, according to the British Standards, institution 2020, a one-hour fire rating is confirmed based on The Limecrete Company LTD mixtures used in the UK (Abbott 2014). The challenge of getting approval for hempcrete, in a general sense, is the reliance on the combination to provide the stated rating. Figure 41 demonstrates the reliance of the lime binder to ensure the fire rating. Test 1 is a hempcrete block with half the required lime mixture. The second test is the ideal hemp to lime ratios for walls. In the first test, when the torch begins to burn, the material flakes start immediately falling away. Although the block isn't catching fire, the hole is expanding faster than expected. In the second test, the torch has little effect on the block, charring the surface, but no flakes fall away.

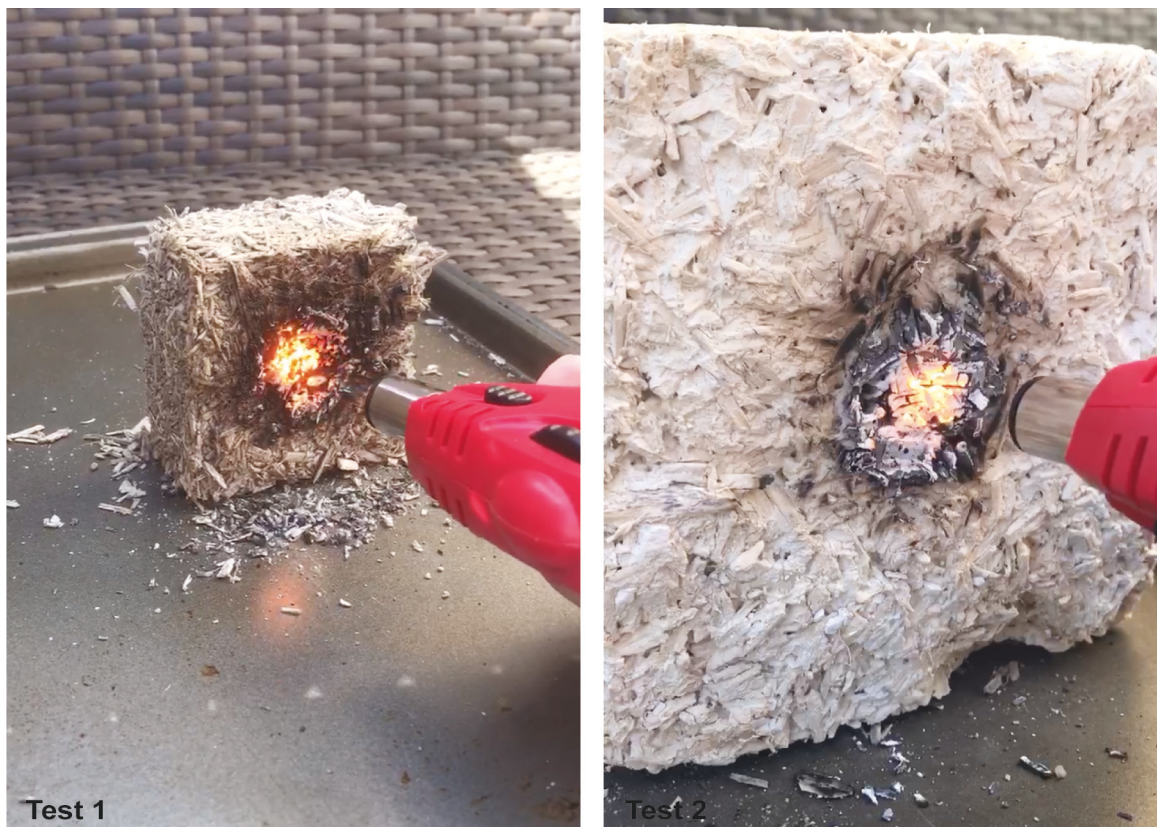

Figure 41: Self conducted fire testing comparing the lime binder ratios.

Pests

Like the fire-resistant characteristic, insects and pests do not like the high alkaline content in the mix, which keep them away.

Mould/Mildew

Hempcrete is resistant to fungus and has anti-microbial properties, which means that hempcrete can resist mould formation in even highly humid conditions. As long as an air gap is provided to dry out the material, no mould will grow in the hemp. In general, finding the right combination of building materials is a bigger problem in the building industry. The increase of synthetic building materials that are “vapour barriers” intended to keep moisture out of the buildings is creating more issues due to improper use. According to several reports, these materials are not performing as designed for the length of time intended. Hempcrete is a breathable thermal mass, resistant to mould and mildew, that promotes the longevity of the envelope that requires a permeable assembly.

Binders

Applications for Hemp-Lime Mix

The binder in the hempcrete mix is responsible for specific characteristics. For example, different ratios of water, lime and hurd can be used depending if the hempcrete is used in the floor, wall or roof.

“The hempcrete binder needs to provide the initial set to the hempcrete with enough strength to support the weight of the drying hempcrete wall (hydraulic set)” (Stanwix and Sparrow 2014, 80). It also needs to allow the water to

continue to dry out of the hemp hurd after the initial set; this requires the wall assembly to be vapour permeable. Lastly, the binder needs long-term structural strength. According to Stanwix and Sparrow, to achieve a successful wall, each of these factors must be met. When it comes to the packing of the mix, the looser the fill is packed, the higher the thermal value will be. By compressing the mix more densely, the thermal value will reduce; however, the structural strength will increase.

Lime Binder

Two types of natural limes found in hempcrete as the binder (Stanwix and Sparrow 2014, 50):

1. Hydraulic lime $\text{Ca}(\text{OH})_2$ (Hydrated Lime or Calcium Hydroxide + Calcium Silicate + Calcium Aluminates): Hydraulic or water exposure set (from hydration), fast-set, high strength and low vapour permeability.
2. Hydrated (Air or putty) lime $\text{Ca}(\text{OH})_2$ (Calcium Hydroxide): Air exposure set (from carbonation), slow set, low strength and high vapour permeability and hygroscopicity.

TYPE	EXAMPLE	SETTING PROCESS	SPEED OF SET	STRUCTURAL INTEGRITY	VAPOUR PERMEABILITY	STRENGTH
AIR LIME / CALCIUM LIME (CL)	PUTTY LIME	CARBONIZATION	SLOW	SOFT	MORE	LOW
NATURAL HYDRAULIC LIME (NHL)	FEEBLY HYDRAULIC (NHL 1-2)	MOSTLY CARBONATION	↑	↑	↑	↑
	MODERATELY HYDRAULIC	MIXTURE OF CARBONATION & HYDRAULIC SET				
	EMINENTLY HYDRAULIC	MOSTLY HYDRAULIC SET				
	NATURAL CEMENTS EX. PROMPT NATURAL CEMENT	HYDRAULIC SET	FAST	HARD	LESS	HIGH

Figure 42: Characteristics of natural lime (Stanwix and Sparrow 2014, 50)

Indoor Air Quality (Ventilation)

Synthetic insulation contains toxic chemicals or volatile organic compounds. (VOCs) these are known to give off harmful gasses into the indoor atmosphere (Stanwix and Sparrow 2014, 55). These VOC's, combined with airtightness of a building, cause poor indoor air quality. The response to this issue has been adding mechanical equipment to help change the air faster to counterbalance the lack of fresh air. Enhanced mechanical systems increase the building's operational cost and emissions over its lifetime.

Using hemp-based material means there are no VOCs in the space. "Low risk of off-gassing or toxicity during the in-use phase of a building, or at end-of-life demolition" (Dhakal 2017) and because hemp requires the wall system to be breathable, no added mechanical systems are needed to increase the air exchanges, keeping the operational cost minimal.

Cost

Material

On average hempcrete, costs are higher than others, however, this is mainly due to the irregularity and difficulty of getting the content. With more popularity and familiarity, they may drastically reduce in time.

Agricultural By-product

Hempcrete uses material from the farming industry as a by-product of other consumer goods. There's an opportunity to reduce the overall cost of hempcrete if the current farmers are growing hemp see a demand for hemp hurd for this purpose.

Labour

Labour cost tends to increase because of the specificity of the process. Contractors familiar with the process would have specialized equipment and be able to achieve a better product and typically faster. Those not familiar with the process run the risk of failure and replacement.

Problems with Hempcrete

As hempcrete gains in popularity, there is also an increase in cases where hempcrete has failed. There are several reasons why one may have issues with this method of construction. One issue arises from a contractor error, “insufficient thought given to the time of year, weather conditions, drying times and management of drying once



Figure 43: First hempcrete test resulting in mould spores due to moisture in the air and not removing the formwork at the appropriate time.

the material has been cast” (Stanwix and Sparrow 2014, 74).

Another issue can arise when the formwork is not removed at the right time. As per Figure 43, mould spores are observed. The use of incorrect volumes of water can also be a common problem. When too much water is added, the dry time is compromised, resulting in mould, flaking and staining on the walls.

Drawbacks to Exposing Hempcrete

Exposing the hempcrete in the interior of a building can add tremendous visual appeal. However, there are a few drawbacks to doing this. Firstly, the cleanability of the walls becomes more difficult, and this can be a concern in a public space. Secondly, the durability of the wall would be a concern; in a higher traffic area, hempcrete walls should be protected, so they don't get damaged. Protection could be done with a wall protection board only in the regions with-in a hitting zone, i.e. chair rails, or with a slatted wall finish, further discussed in Chapter 6: Design.

There are many reasons why it's crucial to pick the right application for the situation. The lower the density of the mix, the weaker it will be; however, it will be more insulative and less expensive. The higher the density of the blend, the stronger it will be, however, less insulative and more costly. In keeping with this, it's essential to determine the desired or wanted outcomes in order to ensure a balance of characteristics. For example, a floor slab requires more compressive strength, where an attic requires very little strength and would benefit from the additional insulation.

Chapter 5: Hempcrete Construction

A mis-conception about hempcrete is the shortage of potential exterior finishes available. In the construction industry traditionally hempcrete would be rendered with plaster and painted using a breathable paint. With the use of rain screen systems, far more options exist, providing that the system maintains breathability. As mentioned in earlier chapters, hempcrete is gaining in popularity, especially in the UK, parts of the United States and Australia. These parts of the world are taking hempcrete to the next level by progressively building, training and testing hemp buildings.

A hempcrete wall is built with natural materials and provides a very high thermal and acoustic insulation. Furthermore, it is 'breathable,' so it provides moisture buffering - passive regulation of humidity, which is beneficial both for human health, because it improves indoor air quality, and the fabric of the building. (Stanwix and Sparrow 2014, 131)

The Plinth

One fundamental exercise when working with hempcrete is to prevent standing water from penetrating it as well as "splashback as rain hits the ground" (Stanwix and Sparrow 2014, 151). When protecting a wall from contact with water, a plinth is used to elevate the hempcrete portion of the wall. The plinth is very similar to the foundation wall but is a separate component. Some consider it to be apart of the main wall; others describe it as part of the foundation. In any case, this party wall is intended to separate the organic material from potential water. If a concrete foundation wall is installed in a project, the concrete can simply extrude approximately 250mm above the finished grade. A damp-proof membrane should be installed on the top of the plinth

to prevent any moisture from wicking up into the hempcrete wall.

In the case of the 1:1 investigation (see figure 44), standard dimension, local brick and cement mortar was used to build up the plinth. This gave a solid base for the sill plate to be bolted to. In this case, 2x4 framing at 400mm (16in) on centre is cast into an 200mm thick hempcrete wall, sitting on top of a 200mm tall plinth.



Figure 44: 1:1 Investigation - Hempcrete cast in place

Depending on the thickness of the hempcrete wall, attention should be given to address the cladding when it meets this point, especially if the foundation or plinth is stepping. Strapping may be needed if one wants to conceal the plinth. However, there may be other requirements to satisfy the specification of the cladding used.

When a project is striving for little to no concrete, alternatives for foundations can be limited due to the availability of labour to construct masonry or stone foundations. Another consideration is to use gabion walls to build a foundation, which is paired with maximizing onsite stone to reduce the carbon emission for transporting stone off-site. This has been used as a footing and foundation to an on-grade building. (Stanwix and Sparrow 2014, 149)

Pre-cast Hempcrete

Pre-cast hempcrete is by far the most familiar of the methods. This method, the basis of this report, is the most effective way to reduce carbon emissions and support the local economy. It is cast-on-site, labour-intensive and requires a lengthy construction time frame. Due to the use of lime binders, the dry time of hempcrete is prolonged. Typically, once the hempcrete is installed, the job site will shut down for up to 4-6 weeks to dry out the material adequately. This time frame is based on rendering the hempcrete as a finish, which requires a low moisture content. However, using a rain-screen method on the exterior and keeping the interior exposed for as long as possible would make it suitable to continue working after 1-2 weeks; however, extra care would need to take place not to damage the soft walls.

Coverage

Some key aspects of applying hempcrete to a design that would relate to a few categories below are ensuring the structural frame (wood studs) encapsulates the hempcrete. It is recommended that there is at least 50mm coverage on the exterior when rendering with lime plaster (Stanwix and Sparrow 2014, 291) This is to help reduce the possibility of moisture reaching the frame. Secondly, the benefits of hempcrete depend on the consistency of the application; during the mixing of the material and the installation.



Figure 45: This structural frame is set in the middle of the wall to give maximum coverage of 55mm around the frame. This is above the recommended minimum for protection of the structural frame.

Shuttering/ Formwork

There are several ways to apply formwork to a wood-framed wall. Figure 46 indicates a few possible options, each with its advantages. This formwork process installs similarly to concrete formwork. However, as it is hand placed and does not create pressure like concrete, the formwork can be made of reclaimed plywood.

In some cases, special plastic formwork is used by companies when doing this work fulltime, as it can be costly to purchase. Traditionally when the structural elements stay exposed, small strips of wood are installed on the insides of the beams to provide nailing flanges for the shutter boards. This technique is illustrated in figure 48. This method helps prevent damage to the finish of the exposed wood.

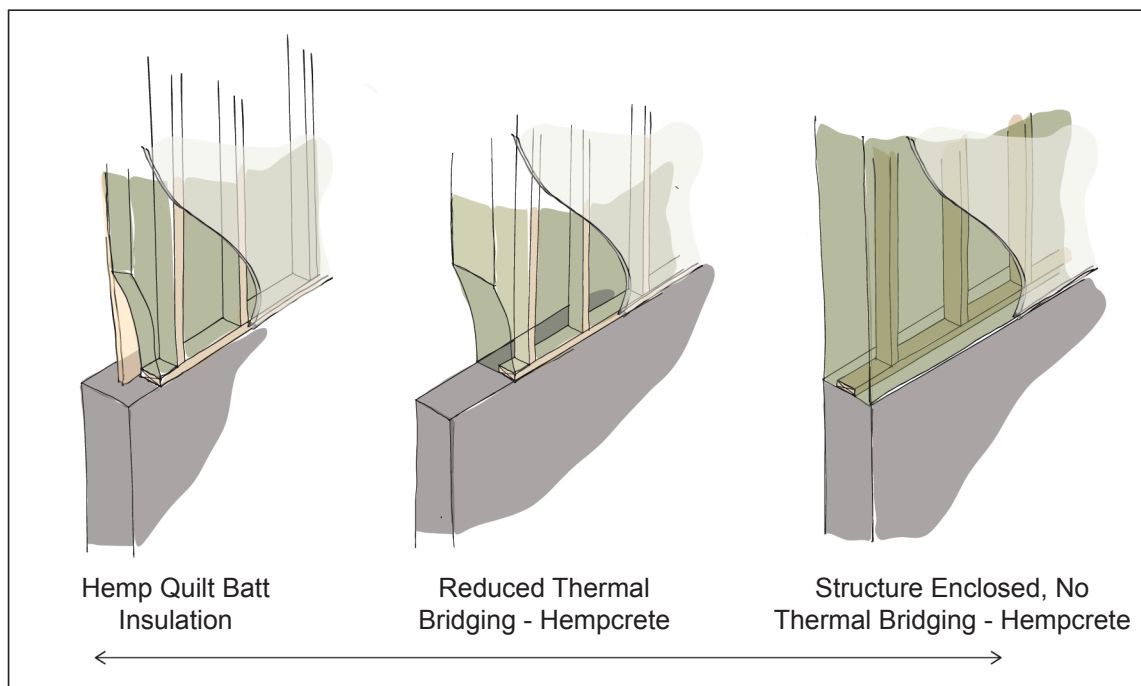

Figure 46: Diagram representing option using the cast-in-place method from the least effective to the most effective regarding thermal bridging.

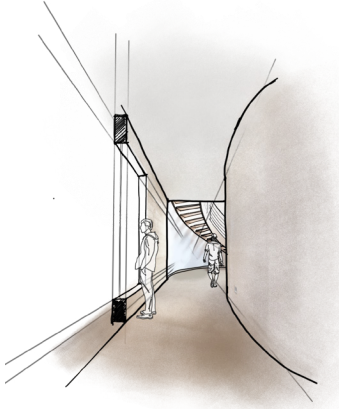

Figure 47: Sketch of a hallway interacting with a curved hempcrete wall.

Curved Walls

When hempcrete is ready to be packed into the wall, the mix can be tested by forming a softball size ball; if it stays together, the mix is ready. Hempcrete has the ability to take on any form, therefore, by using bendable material to create a formwork will allow to create fluid-like structures such as curved walls.

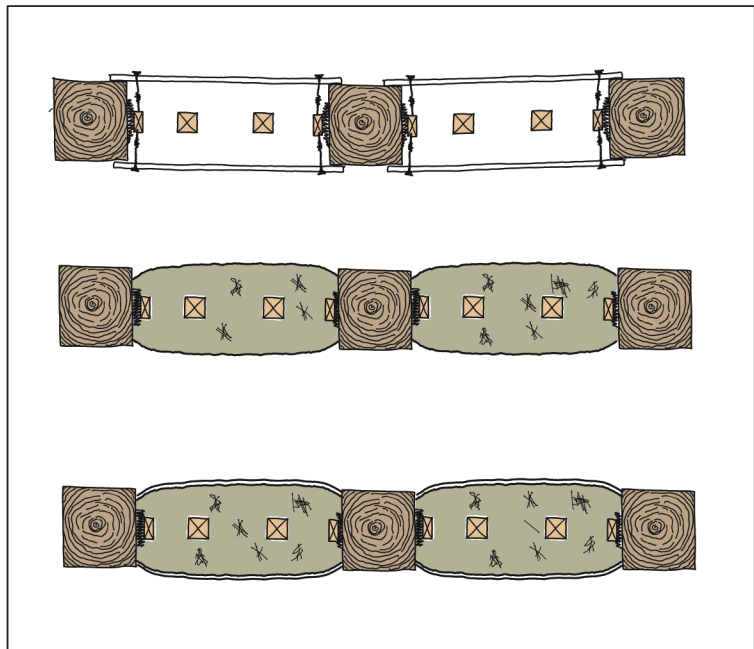

Figure 48: “hempcrete infill in a timber frame with the frame visible on both sides (a) Shuttering fixed prior to placing. (b) shuttering removed and hempcrete shaped back adjacent to main timbers. (c) Finishes applied, closed into main timbers.” (recreated from Stanwix and Sparrow 2014, 276)

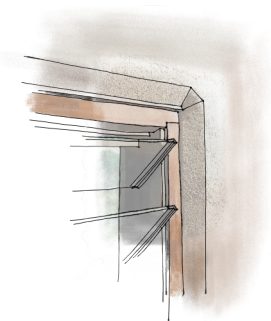

Figure 49: Beveling at the window opening provides a finished look without trimming the window with another material

Details in Formwork

A significant advantage to formwork is the level of detail one can achieve by providing beveling and reveals within the formwork. This adds to the level of detail and the aesthetic profile of the wall.



Figure 50: Instalng hemcrete via spray applied (Hempitecture 2019)

Spray-Applying

Spray applied hemcrete originated in France and has become more popular in the UK since 2012 (Stanwix and Sparrow 2014, 29). Similarly, in the United States, company Hempitecture has expanded to contract work, training and selling equipment to others.

Like other techniques, there are some advantages and disadvantages to this method. This application would result in the most similar to the cast in place version in regards to the framing. However, there are other difficult framing challenges the may arise. For example, it is common to set the structural frame to the inside on the wall and use permanent shutter boards (formwork) to get a surface to spray against (Stanwix and Sparrow 2014, 30). This may result in thermal bridging, as described in Chapter 4. The equipment can become expensive to obtain and is often reserved for contractors doing this regularly. The advantage to this is the speed at which it can be installed, so a small project in scale cast-in-place will more than likely be less expensive; however, as the project grows, the value of the spray-applied increase will increase.

Blocks

Blocks provided a set of advantages that may be favourable depending on the type of project underway. This installation process uses a bed of hydraulic lime and sand, very similar to a traditional masons process when laying brick. Several companies around the world produce hemcrete blocks and all the necessary binders to go with it. Purchasing the block and binder from the same company can have advantages if the builders are new to the products, as all the thinking has been taken care of. IsoHemp Natural Building is a company

based out of Belgium that provides a solution for the entire building. Specifically, their blocks provide a solution for walls but also for the floor. This can improve the time frame of a project as all the blocks have completed the curing process. One disadvantage to point out is the thermal bridging in both the wall system and floor system; however, with a combination of block and cast-in-place, this issue can be solved, refer to Chapter 6 for more information.

The IsoHemp hemp block is a non-load-bearing glued masonry product designed to produce healthy and natural insulating envelopes, partition walls and counter-partitions. It is very versatile; it is highly appreciated by professionals for new construction and renovations, whether they are single-family, collective or tertiary projects. (ISOHemp Natural Building 2020)



Figure 51: IsoHemp blocks used for insulation an subbase on the floor as well as the walls.

IsoHemp Floor System:

Excellent compressive strength (15 T/m²)

Fast installation and efficiency over time that appeals to many architects/designers

High technical flexibility like the option of underfloor heating, insertion of ducts in the screed.

Easy and fast cutting

Laying insulation for an entire building in just a few hours. Simply lay the blocks in staggered rows on the floor and add a layer of reinforced screed (minimum 6 cm thick). Result?

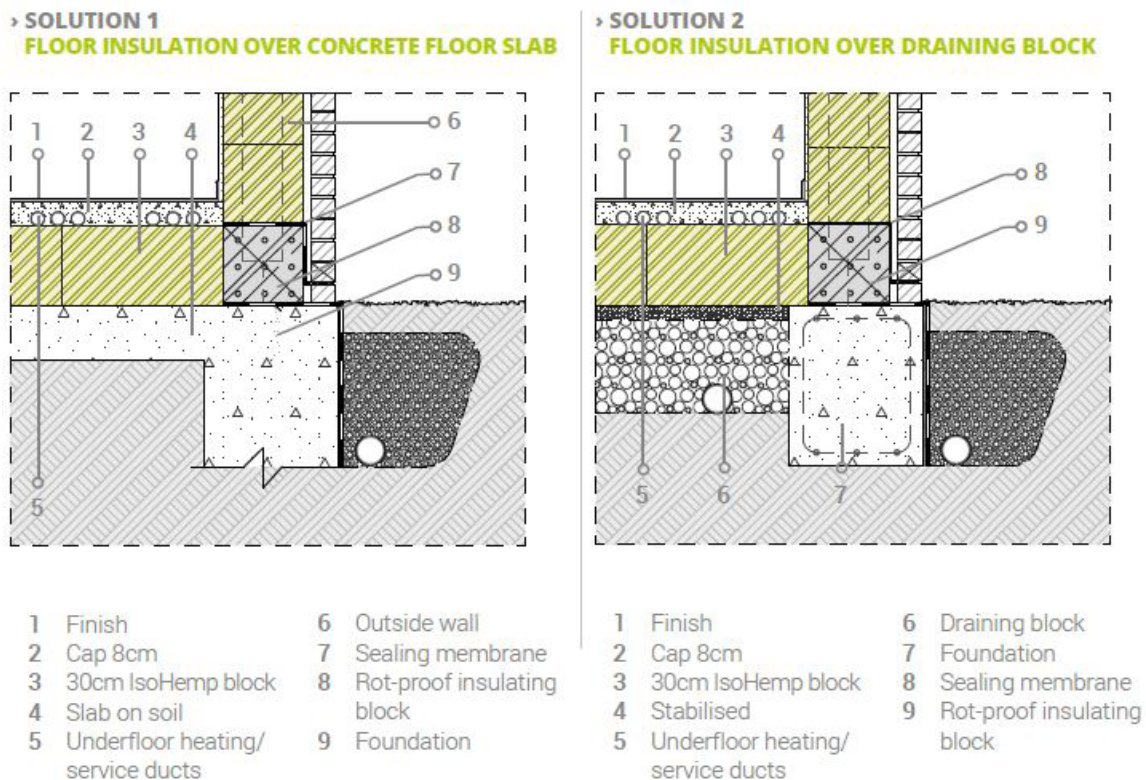

Figure 52: ISOHemp floor detail

Floor insulation without any settling over time and with a real insulating adhesive/screed!

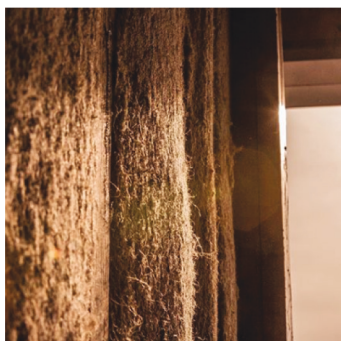

Figure 53: HempWool (Hempitecture 2019)

Hemp Quilt

Hemp quilt is a fibre-based material often used as an underlayment or an insulator; it can also be named hemp mat. It is often made up of mostly hemp fibre but will also contain parts of the woody core. In more recent years, companies have been developing products like the HempWool batt insulation. It uses the tremendous thermal characteristics of the fibre to create an alternative to fibreglass or Rockwool insulation, both with high embodied carbon.

Our HempWool hemp fibre insulation product is non-toxic, carbon-negative insulation made from 92% industrial hemp fibre. Thicknesses range from 2 - 7.5 inches and the R-value is 3.7 per inch, identical to fibreglass insulation. (Hempitecture 2020)



Figure 54: Closeup of the fibres in the hemp quilt product. Note the tight fit of the batts into the stud cavity.

Products like this allow builders to use a sustainable material with standard stud wall construction when hempcrete is not a suitable option. Another consideration is installing the batt insulation into an open stud wall cavity that is going to be used to run electrical services after the cast-in-place wall is formed and complete. This application could be used if staggering construction is essential. For example, to complete the envelope before running conduit for the services.

Wall

Wall Section

The reduction of concrete is one of the most effective ways to reduce our carbon emission. During construction of any new building starts with excavation and typically results in transportation of site stone and rock found under the

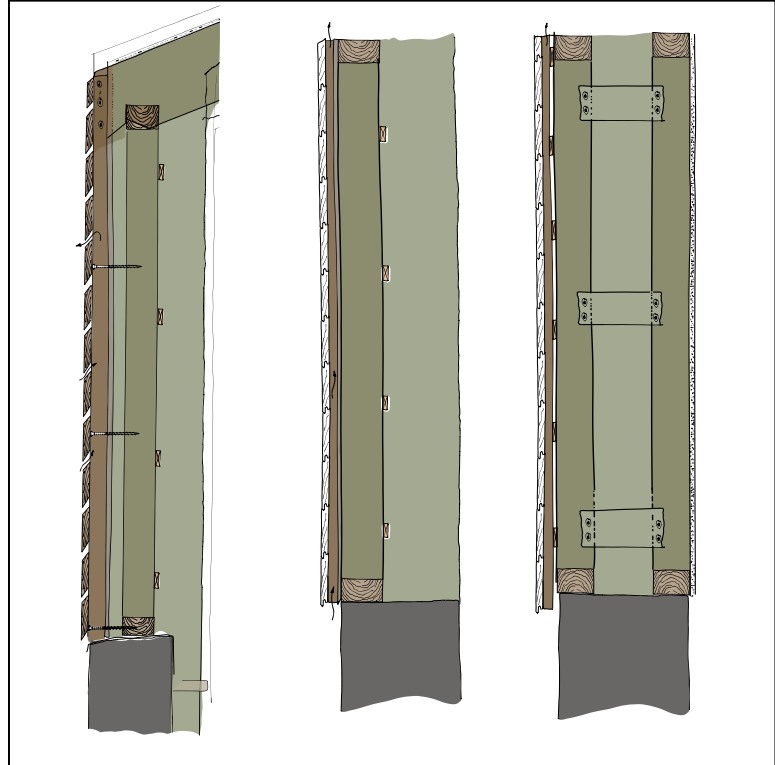

Figure 55: Non masonry cladding details (recreated from Stanwix and Sparrow 2014, 332)

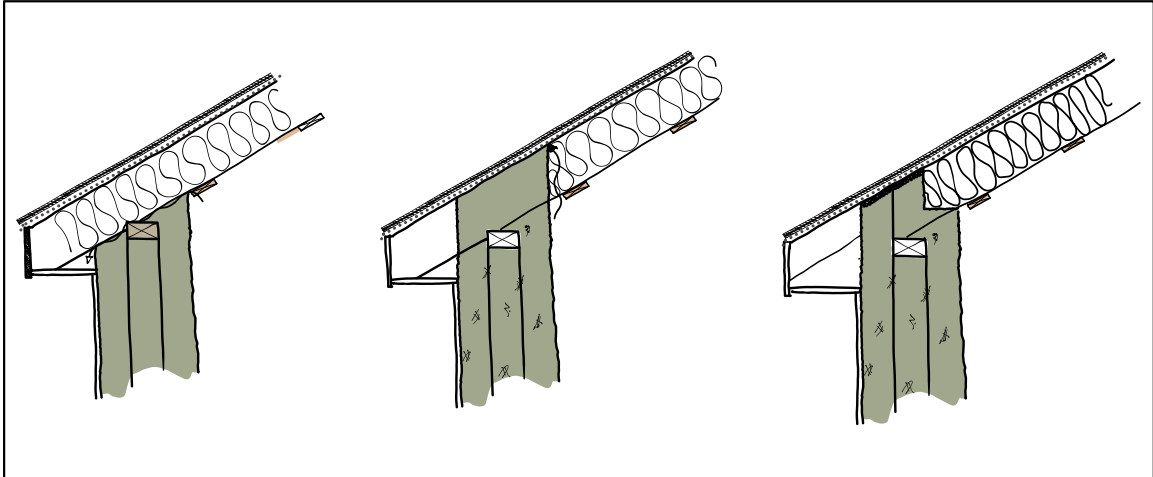

Figure 56: “(A)(B) This wall detail is not a good condition as it allows air leakage between the hempcrete and hemp-quilt insulation.(C) This detail provided adequate sealing between the hempcrete and roof sheathing by sandwiching hemp quilt before installing the sheathing board.” (Stanwix and Sparrow 2014)

surface. One consideration is to use the site stone in gabion walls as a foundation for our building, reducing the amount of concrete needed. This wall section below is an illustration of the proposed research center using the rock found during excavation as the plinth for a smaller portion of concrete towards the surface. This will reduce the transportation cost, but it will also reduce the environmental impacts or relocation of these stones.

Wall-to-Roof

Although hempcrete is a breathable system, the goal is still to reduce air leakage and draft. In Figure 56 there are two ways in which air leakage will cause issues and Figure 56(C) that would be more suitable and prevent leakage, simply by changing the formwork and order of applied materials. This detail is recommended by UK builder William Stanwix.

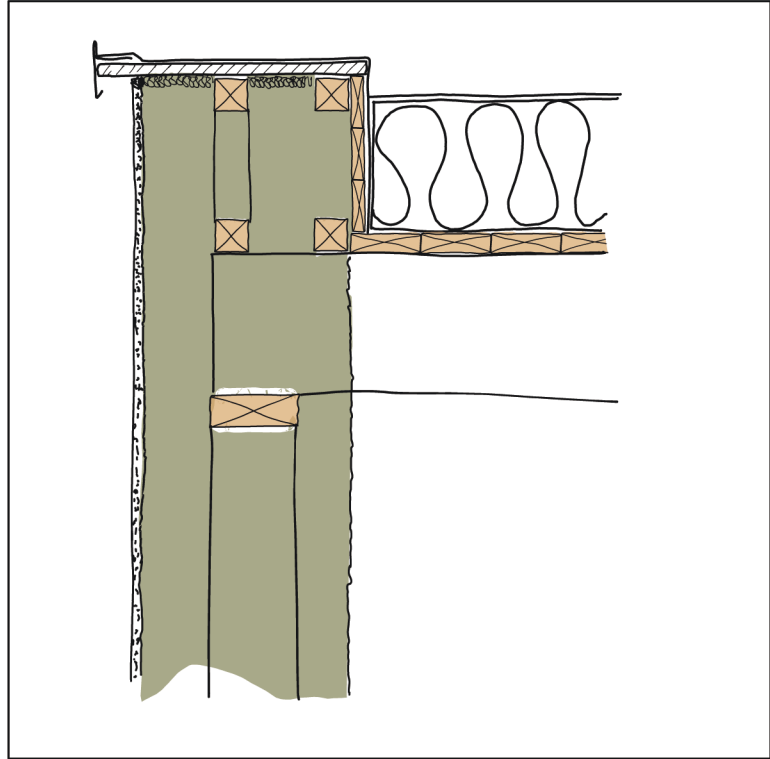

Figure 57: The airtight junction at the eaves of a flat roof with a warm roof build-up. Exposed hemcrete wall finish and exposed structure. (Stanwix and Sparrow 2014, 326)

Floors

Floor Slabs at Grade

According to Stanwix and Sparrow, if a “free-draining, insulating sub-base layer is used, this will replace the use of a DPM (plastic damp-proof membrane), as it provides a layer through which water can only drain down, not rise” (Stanwix and Sparrow 2014, 222). Examples of this type of material that is available include expanded clay aggregate or recycled glass foam aggregate. There are others on the market; however, these are not as sustainable.

Reducing the thickness of the floor hemcrete will allow it to dry faster as there is only one open side with the ability to dry. The size of a slab is typically between 120mm and 200mm, depending on the overall footprint and brand of

binder used (Stanwix and Sparrow 2014, 222). The floor mix, as mentioned before, is often made using a binder rich mixture. This allows the floor to harden more thoroughly, providing a better surface for the floor finish.

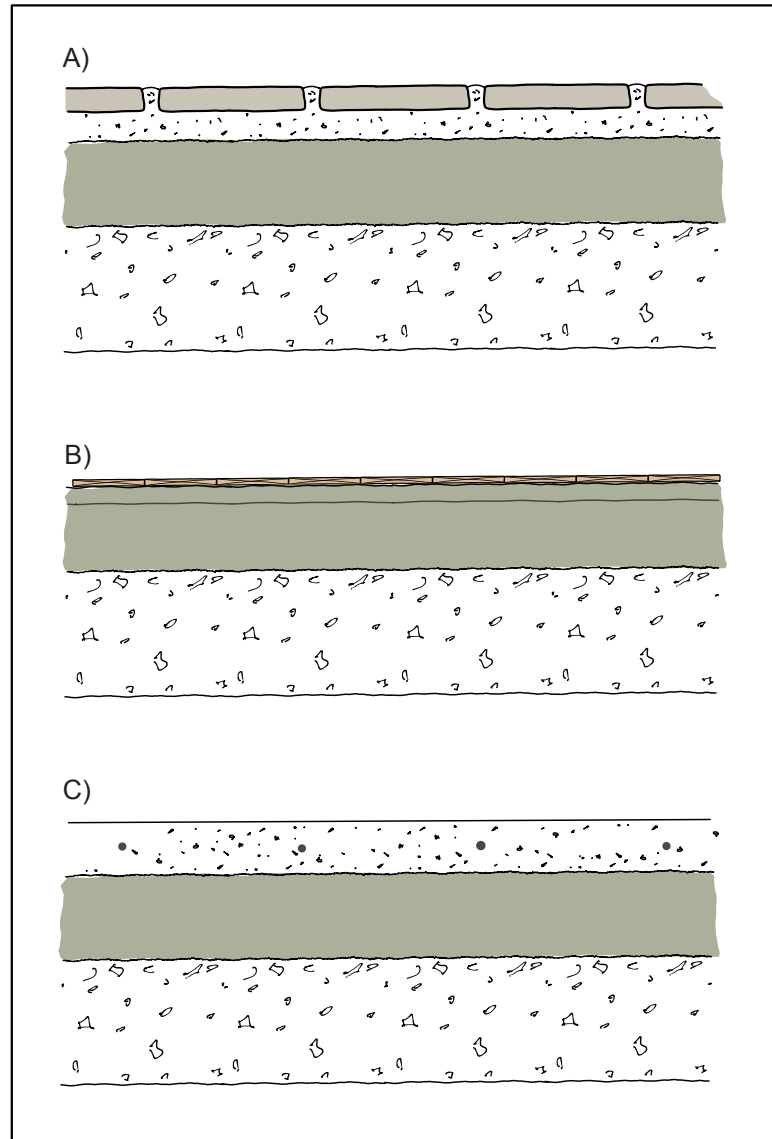

Figure 58: Three different types of floor finish. A) Limestone slabs, lime mortar bed with in-floor heating, lime-rich hempcrete slab, free drainage aggregate, undisturbed soil. B) Rough sawn wood planks, 2x4 embedded, lime-rich hempcrete slab, free drainage aggregate, undisturbed soil. C) Polished lime floor slab with in-floor heating, lime-rich hempcrete slab, free drainage aggregate, undisturbed soil.

Products have been developed to be used for floors and should be followed as suppliers intend. “All Available Binders in the UK - Tradical, Batichanvre and Prompt Natural Cement - can be used to create insulating floor slabs, but Prompt has the advantage that you can walk on it after 20-30 minutes” (Stanwix and Sparrow 2014, 223).

A common risk of using hempcrete as a slab on grade is related to the building’s lifetime. This method requires the floor system to maintain a breathable surface, including the floor finish for its lifetime. Proper maintenance is essential, and documentation of this system is necessary so that a new owner understands the limitation of this system. Otherwise, there is a risk of moisture trapping in the hempcrete, causing mould and failure.

Floor Joist Install

There are a few ways one can use hempcrete in a floor system. Whether the building design intends for the structure to be exposed or to have hempcrete encapsulate the floor system for fire rating, there are many ways a builder can approach this.



Figure 59: A multi-tool is useful for carving and shaping hempcrete. (Stanwix and Sparrow 2014, 106)

Tools and Equipment

Recommended Standard Toolkit

This list of recommended tools is obtained from the book, ‘The Hempcrete Book’ by author and builder William Stanwix:

Framing and Shuttering Tools

- Slide mitre saw
- Circular saw
- Hand saw



Figure 60: A selection of tubs and buckets is essential throughout the build. (Stanwix and Sparrow 2014, 106)



Figure 61: Grid, sponge, and nail floats: used for finishing planter and shaping hempcrete (Stanwix and Sparrow 2014, 107)



Figure 62: A large pan mixer is ideal for mixing hempcrete. (Stanwix and Sparrow 2014, 105)

- 8v jigsaw
- 18v impact driver and 18v drill
- Nail gun
- A basic set of wood drill bits and impact-grade driver bits
- Good quality levels
- Large set square
- Tape measures, pencil, markers pen and chalk line
- Small pry bar
- Small disk grinder
- Buckets

Tools for Hempcrete Application

- First aid kit, including eye station with mirror
- Large 800 litre Mixer
- Long hose
- Gorilla tubs
- Block, pulley and rope
- Protective clothing and equipment
- Olfa knife or similar
- Broom and shovel
- Nail float, rough saw and powered multi-tool
- Dehumidifiers

Tools for Plastering and Rendering

- Paddle mixer (bell mixer)

- Long water hose
- Powered plasters whisk
- Gorilla tubs or buckets
- Plaster's bath or wheelbarrow
- Hawk and trowel
- Floats
- Straight edge
- Bucket trowel
- Sheeting
- Masking tape
- Electric heaters
- Latex gloves and goggles



Figure 63: Hempcrete can be shaped with a nail or grid float after casting (Stanwix and Sparrow 2014, 188)

This list is a basic set of tools one would need to do a cast-in-place hempcrete wall, but do not include any tools related to foundation or plinth work.

Materials and Workmanship

As discussed earlier in this chapter, there is an important note about the technique and quality of the craft. Because of the specificity of the mix and ratio for different applications, it is crucial to have a high degree of accuracy to ensure the attribute you get are the ones you want. At this time, there are no governing standards in Canada for hempcrete, that is not to say it is not allowed to be a building material. It requires approvals from the local jurisdiction before use.

Chapter 6: Hempcrete Construction in Nova Scotia

This chapter explains my discoveries and how, from my exploration and experience in wood frame construction, would approach hempcrete construction in Nova Scotia. We have learned from previous chapters in this report that hempcrete requires a critical eye when accounting for moisture, climate, and installation. On one hand, it has an incredible ability to manage moisture, acoustics, and resistance. On the other, moisture can cause catastrophic failures in a hempcrete building, especially when installed incorrectly. First and foremost, it is always recommended to consult with the manufacturer regarding specific details regarding their product. Whenever possible, use the products together as recommended. They are supported in the specifications as binders are finely designed to work best with the size and ratio of a specific hurd.

The intent here is to push the innovation of how hemp has been used in the past and at present. One of the fundamental considerations has been to combine different application process components to develop more comprehensive wall assemblies; to leverage the advantages and try to minimize the disadvantages while making each application best suit its situation. The Hemps Cafe, Auditorium and the Workshop are three different spaces within the overall building that test different scenarios (see figure 64).



Figure 64: Inhabited Section: This is a section through the proposed Hemp Research Center at Dalhousie University in Truro, Nova Scotia. From left to right entering into the Hemps Cafe, then on the main level is the auditorium, labs, and workshop. Upstairs in the student lounge, studio space and workshop mezzanine.

Exterior Context and Material Palette

An important consideration when designing this building was to preserve the material palette seen on the campus currently. The cladding palette consists of vertical and horizontal wood cladding, red brick, cedar shingles, metal roofing and glass panels. All these materials are inherent to the surrounding architecture and suitable for working with hemp. Each element requires a different approach to detailing the wall assemblies. The specific materials studied are brick, horizontal wood cladding and metal and how each of these materials would best apply to hemp.

Hemps Cafe

Connect – The Haptic Nature of Hemp

The Hems Cafe is all about experiencing hemp, to help people understand its opportunity. Using brick on the exterior reminds us of the monolithic nature of hempcrete as you enter into the building. The wall on the interior is exposed, allowing people to feel the roughness and textures of the hemp material mixed with lime. Hempcrete will provide thermal value and comfort in a space where many people come and go, rest and socialize.

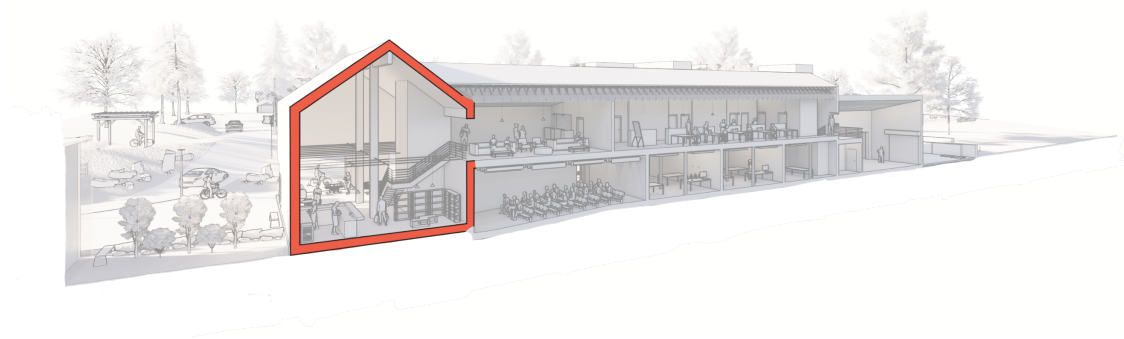

Figure 65: The Hemp Cafe is a double-height space connecting the public Cafe and shop with the student lounge area.



Figure 66: Student Lounge - a combination of exposed hempcrete and plastered walls create a space of warmth and comfort for relaxing and studying. The selection of walls or ceilings for exposed hempcrete is based on those with minimal risk of damage, balancing the overall space.

Connecting people to the textures of this material is valuable. To fully appreciate this material, we need to experience it first-hand. By testing hempcrete in environments where people can experience the texture, lighting, materiality and comfort of hemp through architectural language is how we will check this. The haptic quality of a café is an excellent program where users will experience “all things hemp” in a café showcasing hemp in its versatility of products, including but not limited to food, furniture and textiles.

Fitting Into the Existing Context

Brick is a common building material used in Nova Scotia and can easily be used with hemp as the insulator. Typically this assembly would then get finished with plaster on the interior; however, in this case, the intent is to keep it exposed as mentions above. In order to do this, the wood frame construction is installed then laterally supported. Following this is the brick cladding using the wood framing

as a substruction to tie back. The brick acts as one side of the formwork for the hempcrete.

It's essential to pre-run any mechanical and electrical at this point, as we will not want to interrupt the hempcrete after installation. This will disrupt the finish as we are keeping this area exposed. Alternatively, all the central servicing can be installed below the 1m markers as there will be a wall protection board installed to prevent damage to the walls from regular wear and tear in public space.

Fitting Into the Existing Site - Drainage

It is essential to consider where a building is placed within the site to minimize the risk of moisture damage. It is important to reduce the interruption to the existing rock garden while adjusting the grade to eliminate groundwater and run off to come into contact with the building.

As described in figure 67, the topography in the front area of the building allows natural drainage and collection of water to distribute into the soil naturally. During heavy rain, the basin will fill, allowing the gardeners to use the water for irrigation while the use of rocks helps promote natural drainage. Pathways against the building are sloped at a minimum of 2% to reduce the amount of water the perimeter drainage needs to handle. It's a good idea to elevate the building to reduce the amount of excavation and bring the floor plate above the ground plane.

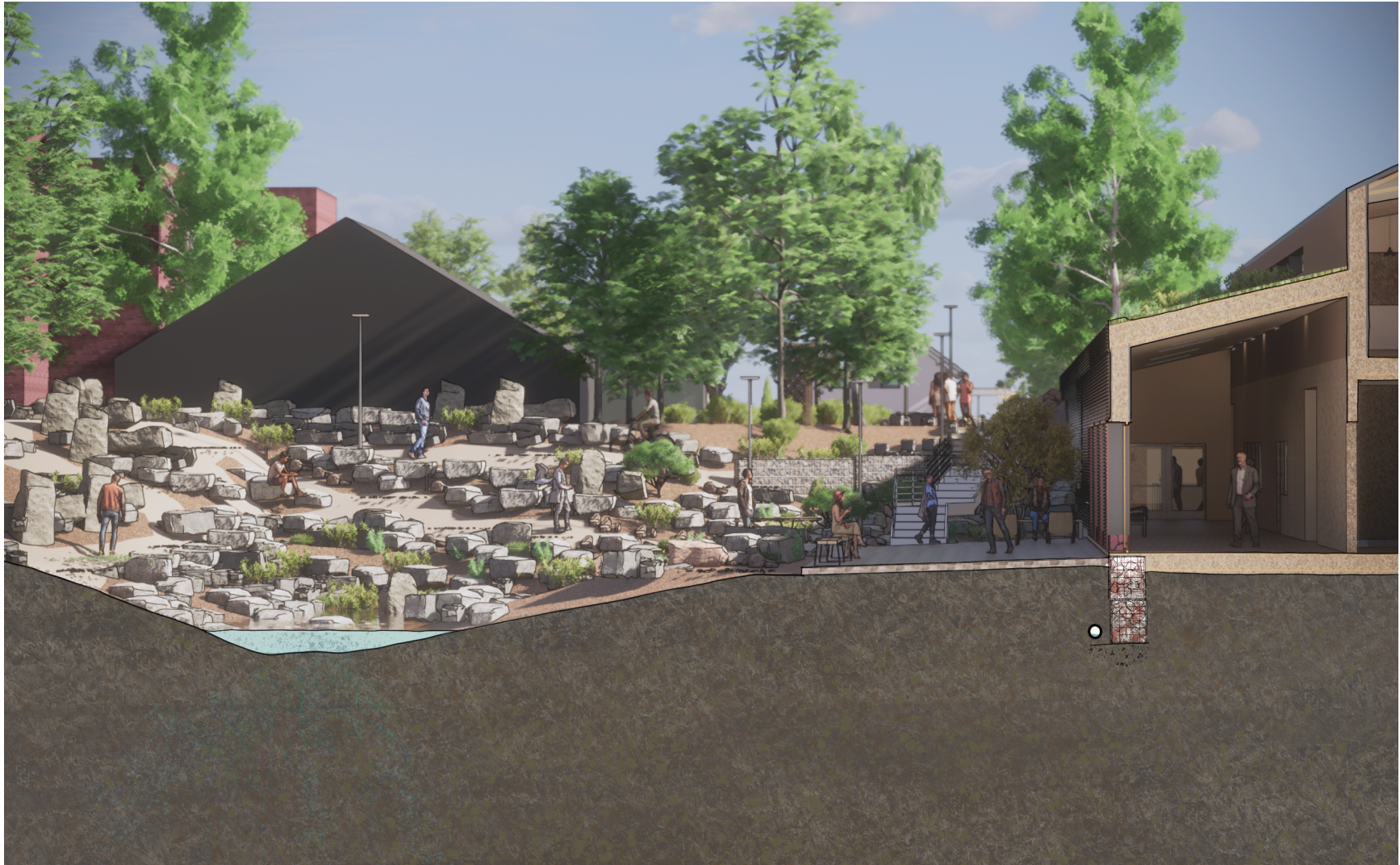

Figure 67: Site drainage section - grading the surrounding on the building to reduce the risk of moisture infiltration is critical for a hempcrete building. Especially on the north-face as it has less sun to promote drying.

Acoustic Performance

Absorbing Sound Into the Wall

Due to hempcretes natural ability to take any shape, it can be formed into more complicated volumes. This technique is used in the exhibition space to promote the diffusion of sound by creating levels in the formwork to create multiple surfaces.

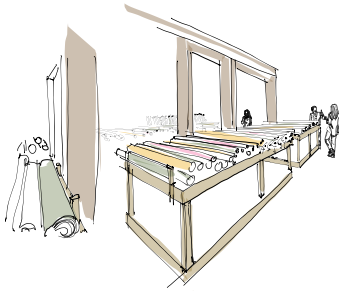

Figure 68: The textiles lab in the Hemp Research Centre is where textile testing, development and innovation would take place.

Fabrication for Acoustic Panels

Often Hemp fibre board is used in furniture as an alternative to OSB. In this case, it can become an excellent backing board to provide rigidity for the acoustic panels. Applying the dense fibre quilt to the board is then wrapped in a hemp textile to use as a hanging acoustic panel.

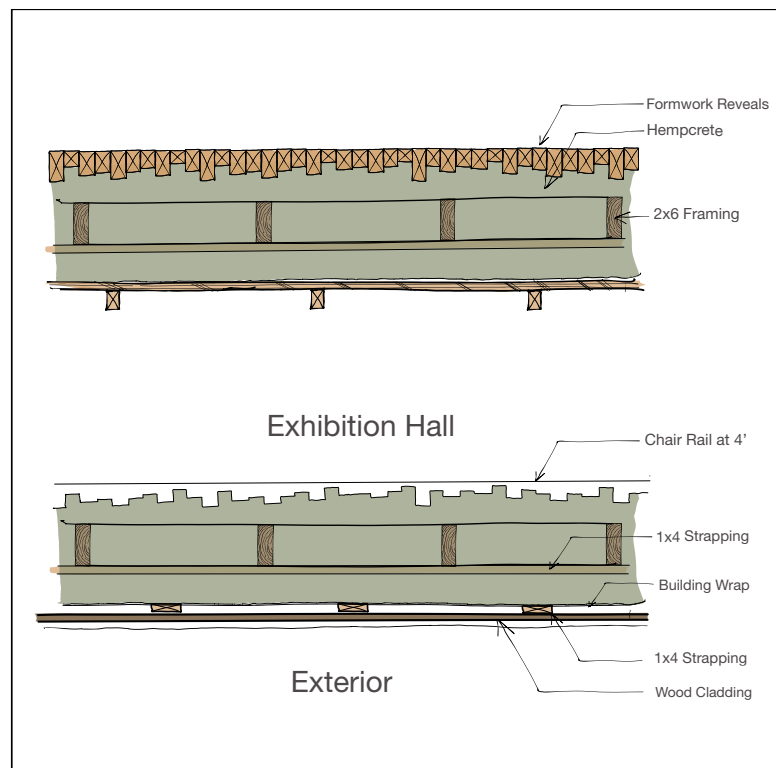

Figure 69: Combining ideas from concrete design by creating more elaborate formwork to create designs and patterns in the exposed hempcrete walls.

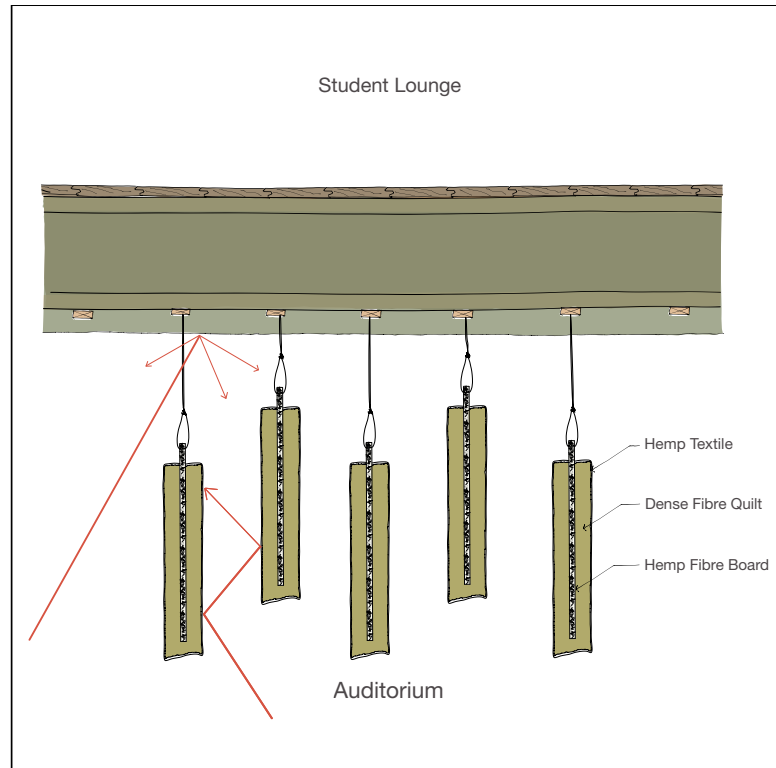

Figure 70: Fabrication of acoustic panels

Sharing Walls with Existing Buildings

The Hemp Research Centre is situated next to the existing engineering building, sharing the existing brick facade demising wall. The section in figure 72 demonstrates that hempcrete can be a suitable insulator and substrate against a current condition. In this case, formwork only needs to be installed on one side, and the brick makes up the other. Brick is removed where the structure needs to connect into the existing building, and added structure runs vertically to provide the floor and roof above the necessary support. Lateral support is taken up by the existing building.



Figure 71: Hempcrete application against existing or new brick. This method is used for the demising wall between the extension engineering and the Hemp Research Centre. (ISOHemp 2020)

Acoustically the hemp provides excellent sound separation from the adjacent program in the existing building. As for the fire rating, the existing brick will provide the requirements;



Figure 72: The shared demising wall between two buildings - In this section, the hemp textile lab shares a wall with an engineering lab. Offsetting the height of the new building allows sunlight to enter into the studio space.

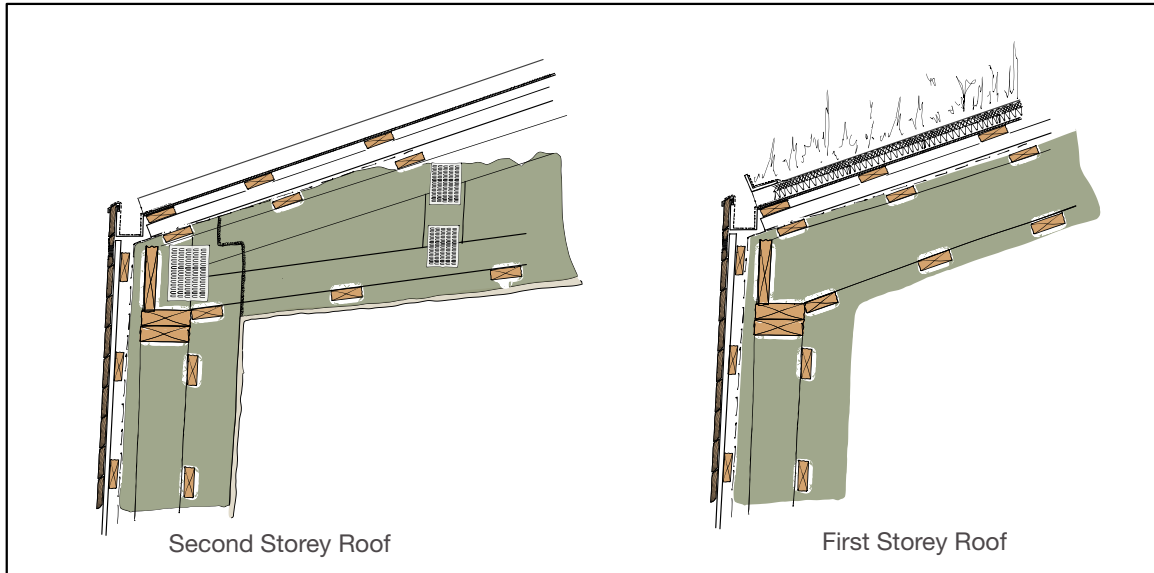

Figure 73: Grass roof - Using recycled metal to produce standing seam roofs to get a substrate to install a grass roof. This helps the building fit into the existing agricultural campus context, contrasting against the rock garden.

however, the added hemp will increase the rating and provide solutions to the areas that the brick is being removed.

Concealing Gutter System

Although this topic is not directly related to acoustic performance, its important to discuss how we can expose the interior of the wall and how water is dealt with, knowing that the wall assembly is required to be breathable to prevent rot. This is achieved by separating air space with adequate ventilation to allow any moisture against the hemp to dry out.

The Workshop

Durability

Hempcrete can be a highly suitable material for areas that require durability if appropriated the right way. In this case, we have a workshop dedicated to the development of hempcrete. The workshop framing consists of supporting exterior walls and a mid-span supporting wall. These walls



Figure 74: Cross Section relationship between the workshop and the existing greenhouse. The profile of the roof allows the sun full access to the green house year around.

are supporting a green roof above. The walls are made up using two main methods of construction, the hempcrete blocks and cast in place. These methods allow us to utilize the characteristics of hempcrete for its fire resistance, pest resistance, and mould and mildew.

Fire Resistance

Columns

Some consideration when using hempcrete for its fire-resistant properties can save money on a project. If we take what we've learned in the previous chapters, we can apply

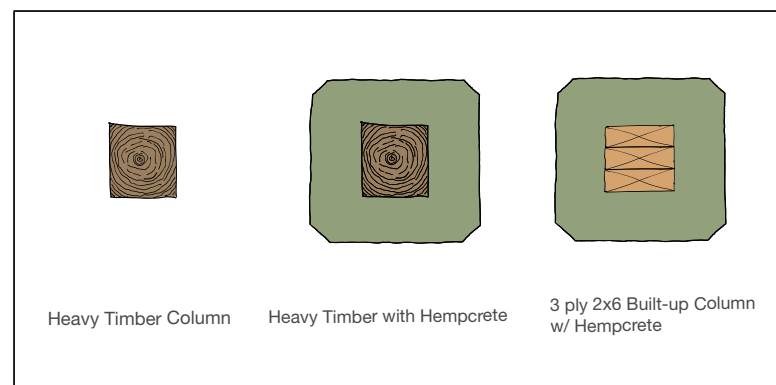

Figure 75: This illustration is proposing to fire rate columns using hempcrete similar to steel cast into concrete with the hopes of reducing the need for old-growth trees. Any laminated lumber would need to be fastened using galvanized fasteners to prevent rusting.

it to other aspects of construction. For example, instead of using a heavy timber post to meet the requirements of fire rating, we use nominal lumber and cast it in hempcrete. This not only creates a visual pleasing esthetic but also satisfy necessary requirements. This also reduces the need for old-growth trees.

Building Below Grade

A. Sloping grade - Sloping grade away from the building to reduce the amount of water that makes its way to the foundation

B. Creating a daylight perimeter drain acts to eliminate the water surrounding the building and create an interest in the landscape along the path around the building.

C. Vapour/Moisture Barrier - If water makes its way towards the gabion wall foundation, there is a vapour barrier preventing moisture from travelling into the stone gabion wall. Typically the use of vapour barriers would not be suitable with hempcrete. However, the use of the air gap allows for this.

D. Foundation - To reduce the use of concrete welded wire mesh with site collected stone to provide the structural requirements necessary to retain the earth. The wall slopes back towards the earth to offset the horizontal loads against the wall.

E. Air Gap - The air gap provides the necessary space for the hempcrete to dry if in the even moisture gets into contact. The air gap is connected from under the slab, through the wall and up to the roof. Effectively creating two separate envelopes—the interior contains the hempcrete

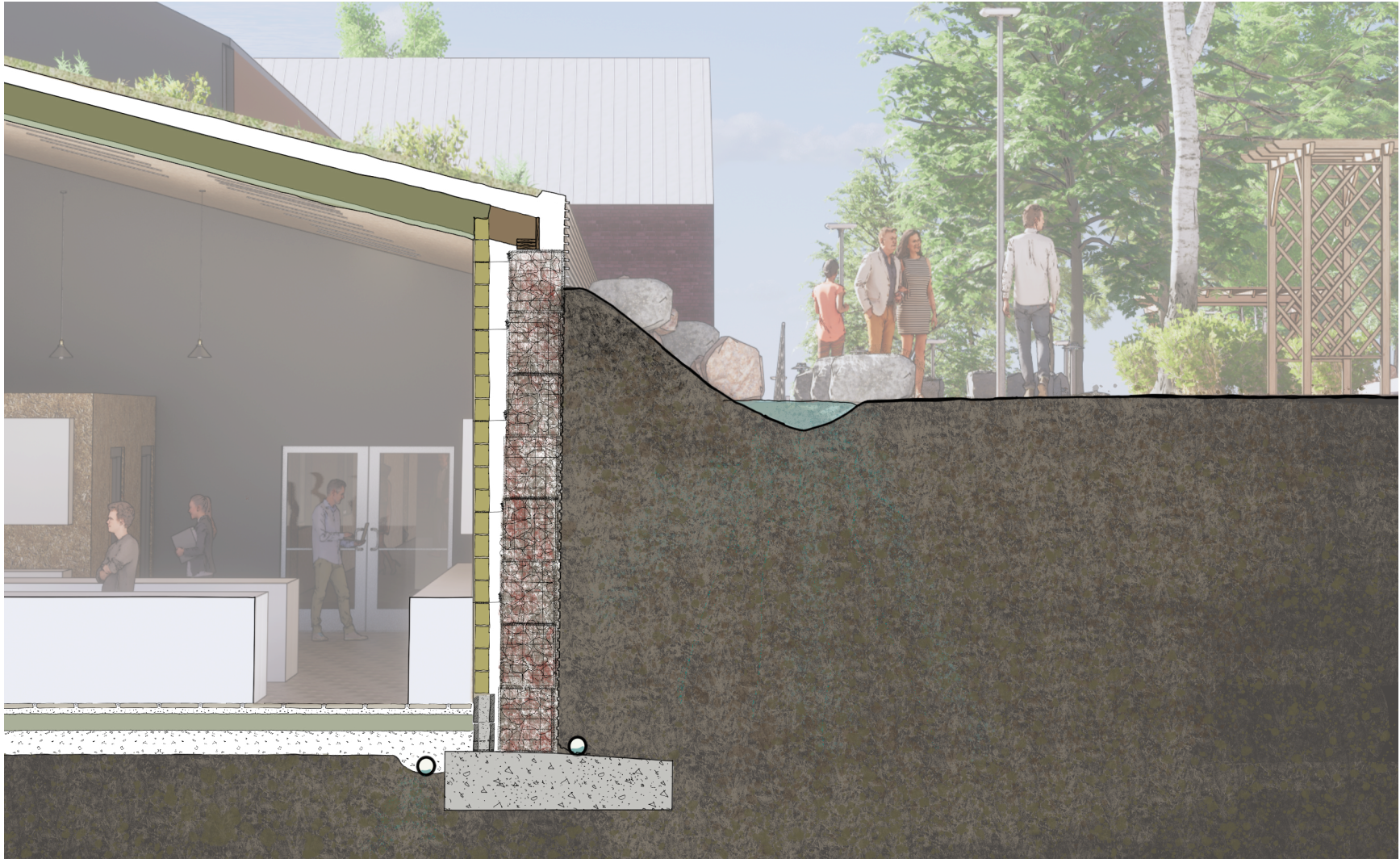

Figure 76: This section illustrates how to use hempcrete in an underground situation when moisture is a concern. The use of hemp block, among other reasons, is beneficial as it's installed with the moisture content already removed, reducing the risk of mould during its install/curing time. The use of the welded wire mesh and site gathered stone minimizes the use of concrete.

insulation and the exterior providing the moisture protection and structural needs.

F. Perimeter drains - If any water makes its way towards the footings, it will be picked up by either the exterior or interior footing drain. Both provide moisture protection around the entire building with them daylighting at each end.

G. Tiebacks - Tiebacks are used for the hempcrete block wall system to provide lateral support. Ties are fastened into the gabion wall and embedded into the lime mortar as the wall is assembled.

H. Green roof assembly - see figure 73

I. Limestone/Hempcrete floor assembly - see figure 58 for detail.

The three key elements discussed in this chapter are only a start of what's possible for hempcrete in Nova scotia and Canada at large. The intent with the content above is to discover and outlines the possible arrangements one could use when working with hemp without deviating too far from standard construction practice. The hope is that these ideas backed with this research would inspire people to believe in hemp as a viable building material.

Chapter 7: Conclusion

This thesis only scratches the surface of how hemp-lime composites can reduce carbon emission in the built environment. Hemp has many valuable characteristics that can make it a usable resource in modern day building. Its use is not limited to special cases or heritage buildings, but in fact could replace some of the non-sustainable standard practices currently used in construction in Canadian climate.

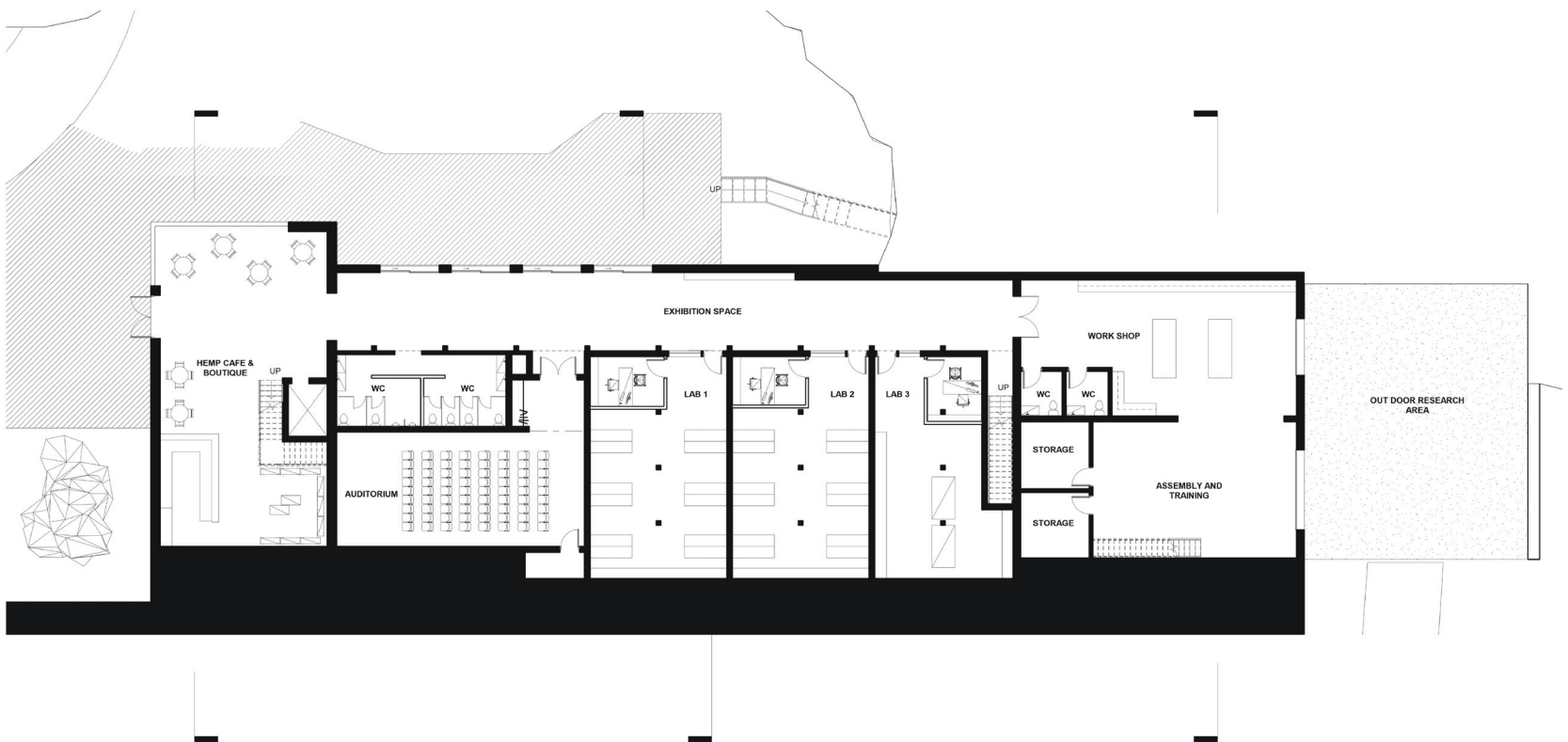

Appendix 1: Ground Floor Plan

Appendix 2: Second Floor Plan



Appendix 3: Material Investigation





Appendix 4: Final Defence Pin-Up

References

- Abbott, Tom. 2014. "Hempcrete Factsheet." The Limecrete Company LTD Sustainable Construction. <http://limecrete.co.uk/hempcrete-factsheet/>.
- Allin, Steve. 2019. "Why to Build With Hemp?". Video, 1:41. <https://www.facebook.com/HempToday/videos/1064309493741782/>.
- Aotta. 2018. *Eco-Friendly Sound-Absorbing Panels Made of Hemp Husks, by Aotta*. Design Boom. <https://www.designboom.com/design/aotta-sound-absorbing-hemp-husks-panels-10-01-2018/>.
- Architecture 2030. 2018a. *Steel*. Carbon Smart Materials Palette. <https://materialspalette.org/steel/>.
- Architecture 2030. 2018b. *Wood*. Carbon Smart Material Palette. <https://materialspalette.org/wood/>.
- Architecture 2030. 2019. *Concrete*. Carbon Smart Material Palette. <https://materialspalette.org/concrete/>.
- Architecture 2030. 2020a. *Actions for Reducing Embodied Carbon at Your Fingertips*. Carbon Smart Material Palette. <https://materialspalette.org>.
- Architecture 2030. 2020b. *Bamboo*. Carbon Smart Material Palette. <https://materialspalette.org/bamboo/>.
- Architecture 2030. 2020c. *Insulation*. Carbon Smart Material Palette. <https://materialspalette.org/insulation/>.
- Architecture 2030. 2020d. *Straw-Bale*. Carbon Smart Material Palette. <https://materialspalette.org/straw-bale/>.
- Arrigoni, Alessandro., Renato Pelosato, Paco Melia, Gianluca Ruggieri, Sergio Sabbadini, Giovanni Dotelli. 2017. "Life Cycle Assessment of Natural Building Materials: The Role of Carbonation, Mixture Components and Transport in The Environmental Impacts of Hempcrete Blocks." *Journal of Cleaner Production*. no. 149 (February). 1051-1061.
- Astre, K. 2018. "Digging up Hemp's Dark Roots." Hemp. <https://thehempmag.com/2018/02/digging-up-hemp-dark-roots/>.
- Baggs, David. n.d. "Thermal Mass & its Role in Building Comfort and Energy Efficiency." EcoSpecifier Global. <http://www.ecospecifier.com.au/knowledge-green/technical-guides/technical-guide-4-thermal-mass-its-role-in-building-comfort-and-energy-efficiency.aspx>.

- Current Results Publishing LTD. 2017. *Average Temperature and Precipitation by City*. Current Results. <https://www.currentresults.com/Weather/Canada/Cities/temperature-april.php> <https://www.currentresults.com/Weather/Canada/Cities/precipitation-annual-average.php>.
- Dalhousie University . n.d.a. *Extension Engineering*. Dalhousie University - Campus Map. <https://www.dal.ca/campus-maps/building-directory/agricultural-campus/extension-engineering.html>.
- Dalhousie University. n.d.b. *Collins Building*. Dalhousie University - Campus Maps. <https://www.dal.ca/campus-maps/building-directory/agricultural-campus/collins-building.html>.
- Dalhousie University. 2020. *Rock Garden*. Dalhousie University. <https://www.dal.ca/about-dal/agricultural-campus/about/gardens/rock-garden.html>.
- Dhakal, Ujwal. 2017. "Hygrothermal Performance of Hempcrete for Ontario (Canada) Buildings." *Journal of Cleaner Production*. no. 142 (January). 3655-3664.
- Evrard, Arnaud. 2006. "Sorption Behaviour of Lime-Hemp Concrete and its Relation to Indoor Comfort and Energy Demand." In *23rd International Conference on Passive and Low Energy Architecture*. 1553-1557. Geneva Switzerland: University of Geneva.
- Government of Canada. 2019. *Regulations of Industrial Hemp Seed*. Government of Canada. <https://www.inspection.gc.ca/plant-health/cannabis/industrial-hemp-seed/eng/1532125745804/1532125788650>.
- Government of Canada. 2020. *Industrial Hemp Regulations (SOR/2018-145)*. Minister of Justice. <https://laws-lois.justice.gc.ca/PDF/SOR-2018-145.pdf>.
- Grudzińska, M., Brzyski Przemysław. 2019. "The Occurrence of Thermal Bridges in Hemp-lime Construction Junctions." *Periodica Polytechnica Civil Engineering*. 377-387.
- Hemp Inc. 2015. *Set to Manufacture Industrial Hemp Products*. Retrieved from Hemp Inc. <https://www.hempinc.com/the-reassembly-of-the-decortication-plant-to-manufacture-industrial-hemp/>.
- Hempcrete Natural Building Ltd. 2018. *Compilation of relevant research*. Hempcrete Natural Building Ltd.
- Hempitecture. 2019. Photograph of spray-applied hempcrete. Instagram. https://www.instagram.com/p/Bz_LQRRBYW7/?igshid=178zjv6gzza0.
- Hempitecture. 2020a. Photograph of Hempwool insulation. Instagram. <https://www.instagram.com/p/B7R1FREBi0z/?igshid=uw5dkm5rdf29>.
- Hempitecture. 2020b. Photograph of Hempcrete training session. Instagram. <https://www.instagram.com/p/B8MGHHVHjGr/?igshid=1lutelnvxhq5b>.

- Hempitecture. 2020c. Photograph of Hempwool. Instagram. https://www.instagram.com/p/B8Rm_aJBGpF/?igshid=dje5xhc93ro6.
- ISOHemp Natural Building. 2020. *Hemp Blocks: The Answer to Many Technical Challenges*. ISOHemp Natural Building. <https://www.iso hemp.com/en/hemp-blocks-naturally-efficient-masonry>.
- Johnson, Renee. 2018. "Hemp as an Agricultural Commodity." Congressional Research Service. <https://fas.org/sgp/crs/misc/RL32725.pdf>.
- JustBio Fibre Structural Solutions. 2017. *JustBio Fibre Structural Solutions*. Harmless Home: <http://justbiofiber.ca/projects/>.
- JustBio Fibre Structural Solutions. 2018. *Certification*. <http://justbiofiber.ca/products/certifications/>.
- Kander, Ron. 2019. The Smart Way to Integrate Hemp into Consumer and Industrial Products. Itunes. (E. Harlock, Interviewer) Lancaster Farming Industrial Hemp Podcast.
- Kestner, Dirk M., Jennifer Goupil and Emily Lorenz. 2010. *Sustainability Guidelines for the Structural Engineer*. American Society of Civil Engineers. Reston, Virginia.
- King, Bruce. 2017. *The New Carbon Architecture: Building to Cool the Climate*. California. New Society Publishers.
- Lee, H. 2019. *Bushfires Release Over Half Australia's Annual Carbon Emissions*. Time. Last modified December 23, 2019. <https://time.com/5754990/australia-carbon-emissions-fires/>.
- Lincolnshire Lime. 2020. *Hemp Lime Plaster*. Lincolnshire Lime. <https://www.lincolnshire-lime.co.uk/hemp-straw-chopped-and-cleaned-for-hemp-plaster---fine-626-p.asp>.
- Lion Bulk Handling. 2018. *Cement Manufacturing Process Explained*. Lion Bulk Handling. <http://www.lionbulkhandling.com/2018/11/02/cement-manufacturing-process-explained/>.
- McIntosh, Cameron. 2020. Fiber Side Chat with Cameron McIntosh. Itunes. (E. Harlock, Interviewer). Allentown, Pennsylvania, United States.
- McPartland, John. 2018. "Cannabis Systematics at the Levels of Family, Genus, and Species." *Cannabis and Cannabinoid Research*. 203-212.
- Przemysław B., Barnat-Hunek, Suchorab, Zbigniew, and Kagod, Grzegorz. 2017. "Composite Materials Based on Hemp and Flax for Low-Energy Buildings." *MDPI*. Volume 10. Issue 5. 1-23.
- Rodale Institute. 2020. *Industrial Hemp Trial*. Rodale Institute. <https://rodaleinstitute.org/>

- science/industrial-hemp-trial/.
- Sayigh, Ali. 2014. *Sustainability, Energy and Architecture*. Case Studies in Realizing Green Buildings (First ed.). Oxford, UK: Academic Press.
- Stanwix, W., and Alex Sparrow. 2014. *The Hempcrete Book*. Cambridge: Green Books.
- Strain, Larry. 2017. "10 Steps to Reducing Embodied Carbon." The American Institute of Architects. March 29, 2017. <https://www.aia.org/articles/70446-ten-steps-to-reducing-embodied-carbon>.
- University of Calgary. 2016. "Anthropogenic carbon emissions". Energy Education. https://energyeducation.ca/encyclopedia/Anthropogenic_carbon_emissions#cite_ref-IPCC_SREX_2-0.
- Unknown. 2020. *2019-20 Australian bushfire season*. Global Fire Emissions Database: <https://globalfiredata.org/pages/2020/01/03/2019-20-australian-bushfires/>.
- Unknown. 2020. Photograph of natural hemp fabric. Pinterest. <https://www.pinterest.ca/pin/425379127300887498/>.
- Vienna, Wu. 2019. *Matflow 2.0*. Material Flow - The Material Flow Analysis Portal. <http://www.materialflows.net/visualisation-centre/data>.
- Villanova, V., and Suzie Eckhart. 2019. The Hemptons: Where Hemp Meets Hospitality in Upstate New York. (E. Harlock, Interviewer).
- Vosper, James. n.d. "The Role of Industrial Hemp in Carbon Farming." *GoodEarth Resources PTY. Ltd*. <https://hemp-copenhagen.com/images/Hemp-cph-Carbon-sink.pdf>.
- Zampori, Luca, Giovanni Dotelli, Valeria Vernelli. 2013. "Life Cycle Assessment of Hemp Cultivation and Use of Hemp-Based Thermal Insulator Materials in Buildings." *Environmental Science and Technology*. 47,13, 7413-7420.
- Zizzo Strategy. 2017. "Embodied Carbon in Construction." *The Atmospheric Fund*. Accessed March 20, 2020. <http://taf.ca/wp-content/uploads/2018/04/Embodied-Carbon-in-Construction.primer-final.pdf>.