

Towards adaptive management of mooring systems to reduce the threats of yachting
tourism in marine protected areas.

By

Monica Lynn Reed

Submitted in partial fulfillment of the requirements for the degree
of
Master of Marine Management

at

Dalhousie University
Halifax, Nova Scotia

December 2016

© *Monica Lynn Reed, 2016*

Table of Contents

List of Tables	vi
List of Figures	vii
List of Abbreviations and Symbols Used	x
Abstract	xi
Acknowledgements	xii
Chapter 1: Introduction	1
1.1 Background to the Management Problem	1
1.2 Project Rationale, Output and Objectives	3
Chapter 2: Literature Review	5
2.1 The DPSIR Conceptual Framework	5
2.2 Adaptive Management	7
2.3 Threats of Yachts to MPAs	9
2.3.1 Carrying Capacity of Yachting Tourism	9
2.3.2 Threats of Anchoring	10
2.3.3 Threats of Improper Sewage Disposal	11
2.4 Yachting Tourism in the Grenadine Islands	12
2.5 Mooring Systems	13
2.5.1 Importance of Mooring Systems	13
2.5.2 Yacht Mooring Systems	14
Chapter 3: Site Descriptions	17
3.1 Tobago Cays Marine Park	17
3.1.1 Park Description	17
3.1.2 Management of the TCMP	18
3.2 Sandy Island Oyster Bed Marine Protected Area	18
3.2.1 MPA Description	18
3.2.2 Management of the SIOBMPA	20
Chapter 4: Research Strategy	21
4.1 Threat Assessment of Yachts to the TCMP and SIOBMPA	21

4.2 Management Review	22
4.2.1 Management Review of the TCMP	22
4.2.2 Management Review of SIOBMPA	22
4.3 Field Surveys	23
4.4 Visitation Data	23
4.5 Site Selection for New Mooring Installations.....	24
4.5.1 Siting Moorings in the TCMP:	24
4.5.2 Siting New Moorings in SIOBMPA	25
Chapter 5: Results	27
5.1 Identified threats of Yachts to the TCMP and SIOBMPA	27
5.2 DPSIR Framework for Yachting Tourism Management.....	28
5.3 Management Review	30
5.3.1 Policies Supporting Mooring Management in TCMP	30
5.3.2 TCMP Mooring Management Operations	31
5.3.3 Policies Supporting Mooring Management in SIOBMPA	32
5.3.4 History of Moorings at SIOBMPA	33
5.3.5 SIOBMPA Mooring Management Operations	34
5.4 Field Surveys	34
5.4.1 Field Survey Results of Moorings in the TCMP	34
5.4.2 Field Survey Results of Moorings in SIOBMPA	36
5.5 MPA Visitation and Mooring Fee Records	38
5.5.1 TCMP Visitation and Mooring Fee Records	38
5.5.2 SIOBMPA Visitation and Mooring Fee Records	39
5.6 Potential Sites for New Mooring Installations.....	41
5.6.1 Yacht Moorings in the TCMP.....	41
5.6.2 Small Boat Moorings in the TCMP	43
5.6.3 Zones for Superyacht Mooring Systems in the TCMP	44
5.6.4 Yacht Moorings near Sandy Island, SIOBMPA	45
5.6.5 Dive Moorings in SIOBMPA	47
5.6.6 SIOBMPA Boundary Demarcation Moorings.....	49

Chapter 6: Recommendations	50
6.1 Recommended Mooring Specifications	50
6.2 Mooring Maintenance	52
6.2.1 Importance of Mooring Maintenance	52
6.2.2 Mooring Maintenance in the TCMP and SIOBMPA	52
6.3 Mooring Fees	53
6.3.1 Mooring Fee Collection Procedure	53
6.4.2 Mooring Fee Costs	53
6.4 Sewage Waste Management Options	56
6.4.1 Sewage at Sea	56
6.4.2 National and International Regulations on Sewage Disposal at Sea	58
6.4.3 Regulating Holding Tanks in the TCMP and SIOBMPA	59
6.4.4 Sewage Waste Collection	61
6.4.5 Sewage Waste Treatment	62
6.5 Education and Awareness	63
6.5.1 Promoting Mooring Systems	63
6.6 Carrying Capacity	65
Chapter 7: Conclusion	67
References	69
List of Referenced Personal Communication	75
Appendices	76
Appendix A: Recommended Mooring Systems' Specifications	76
Appendix B: Photographs of Mooring Systems	80
Appendix C: Mooring Systems Management Materials	85
Appendix C.1 The Halas Mooring System	85
Appendix C.2 Mooring Maintenance Schedule	88
Appendix C.3 Log Sheet for Mooring Inspection or Repair	89
Appendix C.4 Mooring Incident Report Log Sheet	90
Appendix C.5 Mooring Management Binder Contents	90
Appendix C.6 Mooring Fee Collection Checklist	90

Appendix C.7 Summary of Standard Operating Procedures for Mooring
Maintenance..... 91

Appendix C.8 Standard Operating Procedures for Mooring Maintenance..... 92

Appendix C.9 Recommended Colour Coding for Mooring Systems 94

Appendix D: Details on Biogas-Biofertilizer Plants..... 95

List of Tables

Table 1. Table showing potential threats associated with yachts in the TCMP and SIOBMPA..... 27

Table 2. Number, location, depth and recommended mooring system components of potential new yacht mooring systems northeast of Jamesby Cay, TCMP..... 76

Table 3. Number, location, depth and bottom type of potential new yacht mooring systems south of Sandy Island, SIOBMPA. 77

Table 4. Number, location, depth and bottom type of potential new yacht mooring systems north of Paradise Beach, SIOBMPA..... 78

Table 5. List of Standard Operating Procedures for Mooring Maintenance (Harvey, 2013). 93

List of Figures

Figure 1. The Grenadine Islands of the Grenada Bank, Caribbean.	2
Figure 2. The DPSIR framework as a cycle and system in the environment (Atkins et al., 2011).	6
Figure 3. Typical Halas style mooring system design (Fairhead and Baldwin, 2015).	15
Figure 4. Manta and pin mooring system (Breda and Gjerde, 1996).	16
Figure 5. Manta anchor securement stages in seafloor (Breda and Gjerde, 1996).	16
Figure 6. Map of the Tobago Cays Marine Park with boundaries (red) and labeled islands, cays and reefs (Google Earth, 2016).....	17
Figure 7. Map showing the MPA boundary (red) of the SIOBMPA, Carriacou, Grenada (Google Earth, 2016).	19
Figure 10. Tobago Cays Marine Park map showing anchorage zones, mooring fields, park boundaries, reef areas and wildlife reserves (TCMP.org).	31
Figure 11. Map showing locations of existing yacht moorings (black and white rings) near Baradal (top right), between Petit Bateau and Petit Rameau (top left) and east of Jamesby (bottom left), TCMP (Google Earth, 2016).	35
Figure 12. Map showing locations of existing yacht moorings (black and white rings) within Salt Whistle Bay off of Mayreau, TCMP (Google Earth, 2016).	36
Figure 13 Current overnight yacht moorings located south of Sandy Island, SIOBMPA (Google Earth, 2016).	37
Figure 14 Current overnight yacht moorings (black and white rings) and small boat moorings (white diamonds) off of Paradise Beach, L’Esterre Bay, SIOBMPA, Carriacou (Google Earth, 2016).....	37
Figure 15 Graph showing the number of yachts and passengers that visited the TCMP from 2009 to 2015.....	38
Figure 16. Graph showing number of boats that overnighted in SIOBMPA for each month in 2014, except for June-September when the patrol boat was out of service (red line).....	40
Figure 17. Graph showing number of boats that overnighted in SIOBMPA each month in 2015.	40

Figure 18. Zones with potential for new mooring installations (pink polygons) and current yacht mooring sites (black and white rings; GoogleEarth, 2016).	41
Figure 19. Map showing locations of current yacht moorings (black and white rings) and the potential sites for new yacht moorings (white rings) northeast of Jamesby, TCMP. MarSIS habitat layers show areas dominated by sand in yellow, seagrass in green and coral in pink (GoogleEarth, 2016).....	42
Figure 20. Map showing current yacht moorings (black and white rings) and sites for small boat moorings near beaches of Petit Bateau and Petit Rameau (Google Earth, 2016).	44
Figure 21. Suggested zones (red polygon) for superyacht mooring systems, west of Jamesby and southwest of Petit Bateau, TCMP. MarSIS habitat layers show areas dominated by sand in yellow, seagrass in green and coral in pink (Google Earth, 2016).	45
Figure 22. Map showing locations of current yacht moorings (black and white circles) and the potential sites for new moorings (white rings indicate yacht moorings; white square indicates small boat moorings) at Sandy Island, SIOBMPA, Grenada. MarSIS habitat layers show areas dominated by sand in yellow, seagrass in green and coral in pink (Google Earth, 2016).	46
Figure 23. Map showing current dive mooring sites (red flags) near Mabouya (left) and Sandy Island (right), as well the anchorage zone south of Sandy Island, SIOBMPA, 2016.....	48
Figure 24. Map showing current dive mooring sites (red flags) and dive sites requiring mooring systems (orange) near Sister Rocks (top left) and around Cistern Point, SIOBMPA (Google Earth, 2016).....	48
Figure 25. Map of SIOBMPA with suggested boundary demarcation mooring sites (purple flags; Google Earth, 2016).	49
Figure 26. Epoxy embedded pin mooring system for small boats (Moir, 2009).	51
Figure 28. Image of the Halas mooring system with a pick-up line, buoy, through line, down line, float and concrete block anchor in the TCMP (Reed, 2016).	80
Figure 29. Image of manta and pin anchor with two pins, TCMP (Reed, 2016).....	80
Figure 30. Image of downline with moderate fouling, TCMP (Reed, 2016).....	81

Figure 31. Image of downline with significant fouling, TCMP (Reed, 2016).....	81
Figure 32. Image of the standard pick-up line with steel timble spliced into the looped rope to prevent abrasion, TCMP (Reed, 2016).....	81
Figure 33. Image of the standard pick-up line with spliced rope loop reinforced with plastic piping to reduce abrasion from vessel lines (Reed, 2016).....	82
Figure 34. Image showing a single manta pin anchor with downline attached, surrounded by seagrass and green algae (Reed, 2016).....	82
Figure 35. Image showing scouring of seagrass from anchor chain without a float, Salt Whistle Bay, TCMP (Reed, 2016).....	83
Figure 36. Image showing concrete block anchor with chain and float that is preventing scouring of the surrounding seabed, TCMP (Reed, 2016).....	83
Figure 37. Image showing a yacht anchor and chain that is damaging a seagrass bed, TCMP(Reed, 2016).....	83
Figure 38. Image showing chain from yacht anchor lying on top of a seagrass meadow next to a conch, TCMP (Reed, 2016).....	84
Figure 39. Image of a pickup line being made with spliced rope and a loop reinforced with steel, TCMP office, Union Island, SVG (Reed, 2016).....	84
Figure 39. Diagram of a biogas-biofertilizer plant showing inlet chamber, digester, biogas outlet pipe and outlet chamber (CEHI, 2004).....	95

List of Abbreviations and Symbols Used

AMMP	Adaptive Mooring Management Plan
CCI	Caribbean Challenge Initiative
GMPA	Grenada Marine Protected Area Program
MarSIS	The Grenadines Marine Resource Space-use Information System
MPA	Marine Protected Area
PSR	Pressure-State-Response
SusGren	Sustainable Grenadines Inc.
SIOBMPA	Sandy Island/ Oyster Bay Marine Protected Area
SVG	Saint Vincent and the Grenadines
TCMP	Tobago Cays Marine Park

Reed, M., 2016. Towards adaptive management of mooring systems to reduce the threats of yachting tourism in marine protected areas.

Abstract

Marine protected areas (MPAs) are often popular tourism destinations, and therefore, must be managed to accommodate tourism while protecting marine ecosystem health. This project explored the potential for adaptive management of mooring systems to reduce the threats of yachts in MPAs, specifically The Tobago Cays Marine Park (TCMP), St. Vincent and the Grenadines, and the Sandy Island/Oyster Bed Marine Protected Area (SIOBMPA), Grenada. Linkages between processes and yachting pressures operating within the MPAs were assessed with the DPSIR conceptual framework. In-water assessments of the current mooring systems were conducted to create mooring databases. Google Earth was used to map the current locations and identify sites for the new mooring systems. Visitation data from the MPAs were analyzed to provide insight on park usage (number of yachts, people per boat, time spent in MPA, size of boats, regulatory violations). A review of literature and management documents allowed for the identification of mooring management best practices, as well as the threats associated with yachts mooring within MPAs. The research informed adaptive mooring management plans (AMMPs) for both MPAs. The AMMPs aim to maximize the benefits of mooring systems and mitigate the threats of yachts to MPAs. Indicators have been selected for monitoring with the intent of informing management adaptations and providing data to enhance the understanding of the MPAs' carrying capacities. This study contributes to the need for mechanisms to ensure that yachting tourism in MPAs does not compromise biodiversity or the delivery of ecosystem goods and services.

Keywords: marine protected areas, mooring systems, tourism carrying capacity, adaptive management

Acknowledgements

This project was implemented through the Caribbean Marine Biodiversity Program overseen by The Nature Conservancy (TNC) with financial support from USAID.

Thanks to Tobago Cays Marine Park staff and affiliates for their collaboration on this project. In particular, special thanks to Kenneth Williamson, Benjamin Wilson, Albert Hansen and Lesroy Noel.

Thanks to Sandy Island Oyster Bed Marine Protected Area staff and affiliates for their collaboration on this project. In particular, special thanks to Junior McDonald, Davon Baker, Senator Norland Cox, Aaron Bartholomew, and Anique Coy.

Much appreciation is extended to Newton Eristhree and Aden Forteau for their ongoing support. Thanks to the interviewed parties that shall remain nameless to maintain confidentiality and to all others that offered professional opinions (refer to reference list of personal communications).

Special thanks to Sustainable Grenadines Inc. for making this project possible. In particular, special thanks to Orisha Joseph, Sonia Jind, Alba Garcia Rodriguez, Krisma McDonald, Kristie Shortte and James Lord for their professional support and encouragement.

Thank you to the Queen Elizabeth II Diamond Jubilee Scholars Program for the training and financial support that allowed me to work on this project. Much appreciation is extended to Becky Field, Dr. Lucia Fanning and Dr. Claudio Aporta for their ongoing support.

Thank you to Danielle Ince for being the Second Reader for this graduate project. I am grateful to have your insight and support.

Finally, thank you to Orlando Harvey, my academic supervisor, for committing expertise and valuable time to the betterment of this project. Your guidance is greatly appreciated. It has been a pleasure.

Chapter 1: Introduction

1.1 Background to the Management Problem

In an effort to manage the multitude of pressures threatening marine ecosystems (i.e. climate change, overfishing, coastal development, etc.), marine protected areas (MPAs) are being established across the globe (Watson et al., 2015). The IUCN has defined an MPA as “Any area of intertidal or subtidal terrain, together with its overlying water and associated flora, fauna, historical and cultural features, which has been reserved by law or other effective means to protect part or all of the enclosed environment” (Resolution 17.38 of the IUCN General Assembly, 1988, reaffirmed in Resolution 19.46 (1994).

Although MPAs are intended to safeguard marine ecosystem health, the areas must be managed effectively in order to meet conservation goals and promote the provision of ecosystem goods and services (Watson et al., 2015). It is becoming increasingly apparent that successful management of MPAs requires an understanding of their biological and physical processes, as well as their associated social and economic aspects (Thur, 2008). A number of methodologies have been developed to allow for the assessment of complex linkages between processes and pressures operating within MPAs, such as the drivers-pressures-state change-impact-response (DPSIR) conceptual framework (GEP, 1993; Ojeda-Martinez et al., 2008). Such tools can facilitate the selection of indicators that can be monitored to evaluate management effectiveness and inform adaptations to the applied strategies (Vandermeulen, 1998). Adaptive management approaches have emerged from the recognition of the importance of evaluating and adjusting approaches in order to ensure efforts are effective, efficient and appropriate given the current socio-ecological context (Ban et al., 2011).

The Grenadine Islands are a volcanic island chain located atop the Grenada Bank in the Caribbean Sea (Figure 1; Grenadines MarSIS, 2015). The northern islands are governed by St. Vincent and the Grenadines (SVG), while the southern islands belong to Grenada.

The Grenada Bank supports the most extensive coral reef and related habitat in the southeastern Caribbean (CCA 1991a, CCA 1991b). Seagrass meadows, lagoons, mangroves, and a variety of patch, fringing and bank barrier reefs provide habitat for commercially important species (e.g. conch, lobster, reef fish), as well as ecosystem goods and services for coastal communities (Baldwin, 2012). Fishing, tourism and marine transport are the foundation of the economies and livelihoods of the region (Baldwin et al., 2006). The marine-based tourism sector includes charter yachts and cruise ships, onshore accommodation and restaurants (resorts, hotels, guesthouses, rental villas), and recreational water-based activities (e.g. SCUBA diving, snorkeling, sportfishing, day boat charters; Baldwin et al., 2006). It is well recognized that coastal and marine tourism often contribute to the decline of coastal ecosystems such as coral reefs, seagrass beds and mangroves (Davenport and Davenport, 2006). It is therefore essential that marine management includes the identification and mitigation of threats associated with coastal and marine tourism in the Grenadines.

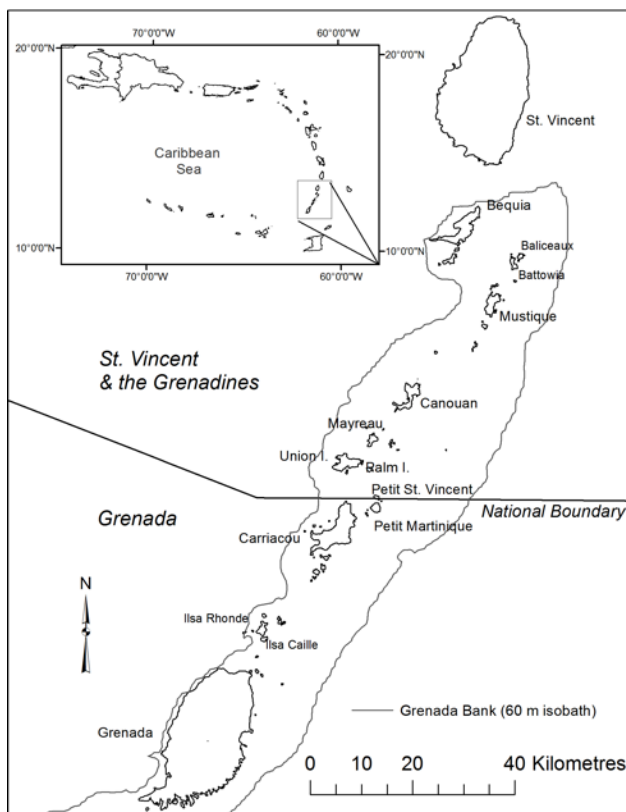

Figure 1. The Grenadine Islands of the Grenada Bank, Caribbean.

In response to the need for enhanced conservation efforts of coastal resources, both Grenada, and SVG have pledged to protect twenty-five and twenty percent, respectively, of the Grenada Bank by 2020 as part of the Caribbean Challenge Initiative (CCI). To ensure protected areas are more than just ‘paper parks’ created to meet percentage targets, marine managers must work to effectively manage the MPAs to meet specific, measurable objectives (Watson et al., 2015). In 2011, the Grenadines Network of MPAs was established to promote trans boundary coordination and collaboration amongst MPAs in Grenada and SVG. The network aims to enhance management capacity in the region through meetings, training sessions, learning exchanges, and monitoring expeditions (SusGren, 2016).

Given the significance of tourism in the region, the MPAs must be managed to protect marine ecosystems while also supporting tourism activities. The marine-based tourism sector includes charter yachts and small cruise ships, onshore accommodation and restaurants, and recreational water-based activities (e.g. SCUBA diving, snorkeling, sportfishing, day boat charters; Baldwin et al., 2006). It is well recognized that coastal and marine tourism often contribute to the decline of coastal ecosystems such as coral reefs, seagrass beds and mangroves (Davenport and Davenport, 2006). It is therefore essential that marine management efforts involve the identification and mitigation of threats associated with marine tourism in the Grenadines.

1.2 Project Rationale, Output and Objectives

Despite its popularity, yachting tourism in the Grenadines has received little research attention. Considering the region’s marine ecosystems provide essential ecosystem goods and services, many of which encourage yachting tourism, strategies to reduce the threats of yachts would contribute to conservation goals and promote the long-term viability of yachting tourism.

The MPAs of the Grenada Bank are a main attraction for yachters, and thus the MPAs are positioned to receive economic gains from the sector, but are also subject to the threats associated with yachting activities (e.g. anchoring, sewage disposal). Management

strategies are needed to ensure that the profits of yachting tourism are attained without compromising the conservation objectives or tourism appeal of the MPAs. The limits on resources available for management and monitoring activities necessitate strategic approaches that evaluated and adapted to promote efficiency.

The adaptive management of mooring systems was identified as a strategy with potential to address the need for better management of yachting tourism within MPAs in the Grenadines. Two core conservation sites of The Caribbean Marine Biodiversity Program – The Tobago Cays Marine Park (TCMP) and Sandy Island/Oyster Bed MPA (SIOBMPA)- are therefore receiving resources to support the installation of additional fixed mooring systems. This research study supported the development of Adaptive Mooring Management Plans (AMMP) for both MPAs. The plans are intended to guide the installation and management of new mooring systems and recommend approaches to monitor and mitigate the impacts of yachts to the MPAs. The following research objectives helped to inform the design of the AMMPs.

- Evaluate threats associated with yachting in MPAs and identify mitigation methods for each threat
- Determine strategic sites and designs for new mooring systems in order to maximize their benefits and minimize associated threats
- Clarify responsibilities and logistics associated with mooring system monitoring and maintenance
- Identify appropriate mechanisms to promote the use of the mooring systems to MPA users and raise awareness on the potential impacts of yachts to MPAs
- Select indicators to monitor that could inform future management adaptations and help establish a yachting carrying capacity for each MPA

Drawing on the principles of adaptive management, this project intends to explore the potential for mooring systems to reduce the threats of yachting tourism in MPAs. The following research question has been identified:

'How can the adaptive management of mooring systems within the TCMP and SIOBMPA reduce the threats of yachts?'

Chapter 2: Literature Review

2.1 The DPSIR Conceptual Framework

The DPSIR framework is a systems-based approach that illustrates key relationships between society and the environment (Atkins et al. 2011). The DPSIR framework was developed from the Pressure-State-Response (PSR) approach, which is based on the notion that anthropogenic activities impact the environment and that adverse environmental impacts drive humans to control the pressures (GEP, 1993). The DPSIR framework is an extension of the PSR approach, incorporating 'Drivers' associated with societal behaviour and economic pressures, and 'Impacts' relating to human welfare and environmental quality (Ojeda-Martinez et al., 2008). In essence, the Drivers are the key demands that create Pressures that lead to State Changes in the system and Impacts on society, which then require a Response (Atkins et al., 2011; Figure 2). Depending on the context, the response can include governance mechanisms, economic controls or demands to insert adaptation, mitigation or compensation measures aimed at reducing the 'Pressures' (Borja et al., 2010).

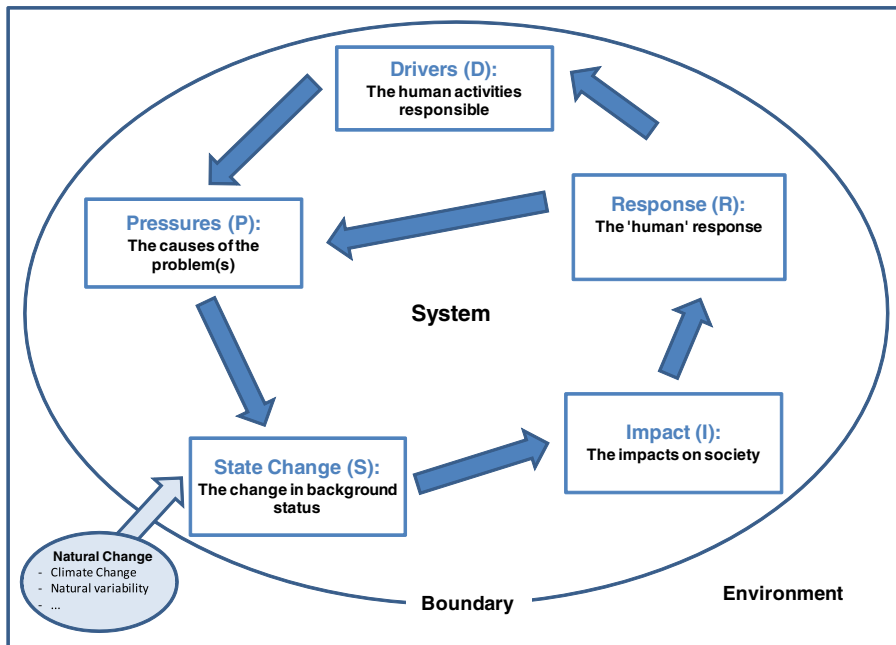

Figure 2. The DPSIR framework as a cycle and system in the environment (Atkins et al., 2011).

The systemic DPSIR framework is considered a philosophy for structuring and communicating policy-relevant research about the environment (Atkins *et al.* 2011) and can allow for a better understanding of the effects of management actions on the different system components (Ojeda-Martinez et al., 2008). Initially, applications of the approach were expert-driven and evidence-focused, however, the DPSIR framework is now also being applied as a heuristic device to promote engagement, communication and understanding between different stakeholders (Atkins et al., 2011).

Marine managers can use the DPSIR framework to improve the understanding of the complex linkages and feedbacks between the causes and effects within environmental issues in MPAs (Ojeda-Martinez et al., 2008). The development of a DPSIR conceptual framework for a specific management objective can help highlight management gaps and identify variables as potential indicators (Mangi et al., 2007; Ojeda-Martinez et al., 2008).

Indicators are used to characterize status, providing an objective system of information and evaluation (Mangi et al., 2007). The “story” told by an indicator can be a useful tool

in communicating the state changes and impacts resulting from pressures, and in informing decision-making processes (Vandermeulen, 1998). Indicators can be used to assess the effectiveness of implemented actions and policies by measuring progress towards environmental targets (GEP, 1993). In an assessment of the reef fishing activities in Kenya using the DPSIR framework, Mangi et al., (2007) ascertain that the need in reef fisheries management to link the science of the causes of change in the status of reefs to the social, economic and legal responses can be best demonstrated using indicators. The study concludes that the DPSIR framework is effective in simplifying the complexity of reef fisheries management and promotes the relevance of indicators to monitor changes to policy makers, scientists and the general public (Mangi et al., 2007).

An analysis of methodological approaches performed by an expert panel of marine scientists selected the DPSIR framework as the most suitable methodology to better understand the effects of management actions on different system components associated with MPAs (Ojeda-Martinez et al., 2008). The expert panel developed a general conceptual framework to analyze the socioeconomic issues, environmental changes and policy responses of MPAs, however, the study highlights the suitability of the DPSIR methodology to also assess specific programs of MPAs (Ojeda-Martinez et al., 2008). This study applies the DPSIR framework to analyze the linkages between yachting tourism, its socio-economic and environmental implications, and management responses.

2.2 Adaptive Management

MPAs are one of many marine management tools that are being applied in an effort to conserve marine biodiversity and promote sustainable use of marine resources. The ability of MPAs to counteract loss of biodiversity and ecosystems goods and services varies with the effectiveness of management measures (Watson et al., 2015). Adaptive management approaches have emerged from the recognition of the importance of evaluating and adjusting approaches in order to ensure efficiency given the changing biophysical, socio-economic and governance context (Ban et al., 2011). Walters and Hilborn (1978) define adaptive management as an iterative process of decision making in the face of uncertainty, whereby objectives and methods change in response to new

information and challenges. Both active and passive adaptive management approaches have been applied in the context of MPA management (Ban et al., 2011).

Active adaptive management is an iterative approach wherein deliberate experimentation and carefully designed monitoring aims to inform decisions that improve management effectiveness (Ban et al., 2011; Evans et al., 2011). A number of iterative assessment methods have been developed to evaluate the costs, benefits, and problems associated with conservation initiatives to help inform management action prioritization and adaptation (Evans et al., 2011; Murdoch et al., 2007; Nicholas, 2012). A vital part of prioritizing investments is to understand how target species or the environment will respond to the management action (Walsh et al., 2012). The evaluation of existing data should inform prioritization, however, actions may be prescribed without evidence of producing a beneficial outcome where data is limited (Walsh et al., 2012). Such actions should then be evaluated to determine their effectiveness and whether the action is worth continued investment or the approach should be adapted (Murdoch et al., 2007).

Passive adaptive management implies learning from past successes and failures to improve management effectiveness (Ban et al., 2011). This approach to adaptive management is more feasible in contexts where management capacity limits the accessibility of data available for evaluation. Similarly, an approach where decisions made on qualitative anecdotal information or past management practices is suitable when urgency necessitates decision-making without a scientific basis. Ban et al., (2011) highlights the trend in applying adaptive management and planning to respond to climate change impacts within MPAs. The approach of simultaneously managing and learning is particularly useful given the uncertainties associated climate change.

Given the plurality of threats and uncertainties facing MPAs in the Grenadines, adaptive management approaches could be applied to improve management effectiveness via adjusting with changing biophysical and socio-ecological contexts. Passive adaptive management would be most appropriate, as data and resources for assessments and monitoring are limited. This research explores how adaptive management concepts can

be incorporated into mooring management in MPAs to improve the effectiveness and efficiency.

2.3 Threats of Yachts to MPAs

2.3.1 Carrying Capacity of Yachting Tourism

Yachting is a popular tourism activity, particularly in tropical waters like the Caribbean Sea. Yachting tourism involves staying and sailing on motor yachts or sailing ships. Since MPAs are often hotspots for yachting, management strategies are needed to ensure yachting does not compromise ecosystem health. Yachts can have negative impacts on marine health, as the use of anchors can cause physical damage to benthic communities (Backhurst and Cole, 2000; Lloret et al., 2008). In addition, pollution from yachts, notably sewage disposal, can negatively impact marine ecosystem health (Lloret et al., 2008). At the same time, MPAs can employ strategies to gain benefits from tourism, such as implementing a user fee system (Thur, 2008). User fees can be a sustainable financing mechanism and also provides records of park usage patterns and rates that can be helpful in assessing the impacts of visitation (Thur, 2008). By monitoring the impacts of visitation, managers can establish a tourism carrying capacity for the area, which is the level of tourism activity that causes an acceptable amount of impact (Bell et al., 2011). Overcrowding of an MPA can reduce its tourism appeal and decrease safety; therefore, in addition to the environmental impacts of yachts, overcrowding should be considered when establishing the yachting carrying capacity of an MPA (Ashton and Chubb, 1972; Bell et al., 2011; Diedrich et al., 2011; Tseng et al., 2009; Lewis 1998).

Considering its popularity, yachting tourism in the TCMP has not received much research attention, leaving the need for research on the environmental, economic and social impacts of the industry (Heeney, 2015). There was, however, a yachting survey conducted in 1994 that determined the carrying capacity of the TCMP lagoon was 50 boats, but the rationale for this estimate is unknown (Hoggarth, 2007). Access has not been restricted and more than 100 yachts can be found within the park during high season (MEDO, 2003). As such, overcrowding of boats has been one of the most commonly

reported problems within the TCMP (MEDO, 2003). To-date, there has not been research to support the establishment of a carrying capacity for SIOBMPA.

2.3.2 Threats of Anchoring

As the popularity of water-based recreation continues to rise, the impacts associated with anchoring are increasingly threatening coastal habitats (Schlöder et al. 2013). Research has shown that coral reef ecosystems are highly susceptible to degradation from anchoring activities (Carilli et al. 2009; Dinsdale and Harriott 2004; Fava et al. 2009; Flynn, 2015; Glynn 1994; Goenaga 1991; Maynard et al. 2010; Rogers and Garrison 2001; Schlöder et al. 2013). Physical damage from boat anchors and their attached chains can dislodge, overturn and crush corals (Goenaga 1991; Glynn 1994; Dinsdale and Harriott 2004; Fava et al. 2009). Anchor damage to corals can cause shifts in community assemblage, leading to reef ecosystems dominated by non-coral taxa, commonly macroalgae (Carilli et al. 2009, Rogers and Garrison 2001, Schlöder et al. 2013, Maynard et al. 2010). When anchoring flattens areas of reef there is a loss of refugia, decreasing the availability and quality of reef habitat (Fava et al. 2009). For instance, Flynn (2015) found that highly anchored areas showed reduced cover of hard corals and sea fans, as well as lower species richness and fish densities compared to rarely anchored sites. Similarly, Lewis (1998) determined that anchor damage to coral reef patches led to the disappearance of coral-associated fishes. Carilli et al. (2009) suggested that chronic stress from anchoring reduces coral resilience to global climate change.

Boat anchoring also negatively impacts seagrass ecosystems (Creed et al., 2008; Milazzo et al., 2003; Montefalcone et al., 2008). Anchoring is one of the many anthropogenic activities contributing to the worldwide loss of seagrass ecosystems (Short and Wyllie-Ech- everria, 1996; Hemminga and Duarte, 2000), and is of particular concern in marine parks where tourism leads to the frequent use of anchors (Creed et al., 2008). The negative effects caused by physical anchor damage have been recorded at the individual plant level, as well as the population level (structure of the seagrass meadow; Montefalcone et al., 2008). The shoot density and rhizome baring of the seagrass were observed to be strongly impacted by anchors, especially in areas where the cover of the

meadow was low (Montefalcone et al., 2008). Similarly, research on the effects of anchor damage on an algal dominated seagrass bed indicated anchor use has created scars that fuse together and reduce seagrass cover and alter community composition (Creed et al., 2008). It is thought that the loss of seagrass structural complexity can have indirect detrimental effects on associated faunal assemblages (Garcia-Charton et al., 1993). Furthermore, anchoring can act as a vector for the invasive seagrass *Halophila stipulacea*, which is impacting native seagrass and associated fish and epibiota communities in the Eastern Caribbean (Willette and Ambrose, 2009; Willette and Ambrose, 2014; Willette et al., 2014). These findings highlight the imperative necessity to regulate anchoring activities in MPAs.

2.3.3 Threats of Improper Sewage Disposal

The impacts of sewage from yachts depend on boater practices, such as holding tank usage, and on the flushing characteristics of the location (Hoggarth, 2007). Discharge of nutrient-containing wastewaters, such as sewage from yachts, can result in high nutrient levels and low oxygen levels in the ambient water. The effects of nutrients are related to the capacity of the receiving water to accept, dilute and disperse discharges (Hawker and Connell, 1989). Nitrogen and phosphorus levels are the major water quality parameters affected by sewage discharge (Hawker and Connell, 1989).

The primary stresses on a coral reef community associated with nutrient enrichment (eutrophication) are connected to increased attached algal growth, localized dissolved oxygen depletion and, in some instances, elevated concentrations of plankton in the water column (Hawker and Connell, 1989). Coral morbidity and mortality associated with sewage inputs are typically a result of competition with algae for space and light (Marszalek, 1981). Increases in inorganic nutrients and turbidity levels resulting from sewage disposal have been found to cause substantial ecological shifts in coral reef ecosystems (Hawker and Connell, 1989; Reopanichkul et al., 2009). For instance, increased inorganic nutrients and turbidity levels associated with wastewater disposal have been tied to substantial ecological shifts in the form of (i) increased macroalgal

density and species richness, (ii) lower cover of hard corals, and (iii) significant declines in fish abundance (Reopanichkul et al., 2009). Similarly, Hawker and Connell (1989) found water nutrient enrichment in coral reef systems resulted in the loss of corals and a dominance of filter and detrital feeders such as sponges, sea cucumber, oysters and clams.

Since hypoxia, meaning low oxygen levels, narrows the thermal tolerance an organism by reducing its metabolic scope, reductions in oxygen availability can have detrimental impacts on marine ecosystems (Hawker and Connell, 1989).

Eutrophication via waste disposal can also lead to sporadic phytoplankton blooms. Phytoplankton outbreaks can deplete oxygen and, in some cases, release toxins that cause filter feeders (e.g. mussels, clams, etc.) to be deadly to humans if consumed. These blooms, commonly known as ‘red tides’ have detrimental impacts on marine ecosystems and often negatively impact local fisheries and marine-based recreational activities.

2.4 Yachting Tourism in the Grenadine Islands

The Grenadine Islands’ picturesque volcanic islands and turquoise waters have been attracting yachters for decades. Yachters either sail private vessels or charter a yacht for their trip and typically visit from December through to April (Baldwin et al., 2006). In 2006, six charter yacht companies were operating 519 boats in the Grenadines. It was reported that about 73% of the chartered yachts are rented ‘bareboat’, meaning no crew is provided (Baldwin et al., 2006). Given that tourists are responsible for operating the vessels rather than professional boat captains, it is likely that bareboat yachts pose more of a threat, both in terms of boater safety (e.g. risk of collision) and environmental impacts (e.g. risk of grounding events).

The yachting sector provides economic benefits to charter yacht companies, marinas and other vessel services, water-based recreational operators and onshore tourist restaurants, shops and services. Although the region has experienced economic benefits from

yachting tourism, the industry has had significant impacts on the marine ecosystem health (*i.e.* reduced water clarity and quality leading to loss of corals, enrichment of water, leading to increased algal growth, reduce bathing water quality which can lead to infections; Joachim, 2008). Baldwin *et al.*,(2006) found that tourists perceived yachting activities to pose the following threats:

- Illegal activities of French (*i.e.* Martinique & Guadeloupe based) charter yachts (anchoring on reefs, illegal fishing and clearance procedures)
- Theft and harassment of guests
- Damage to the coral reefs (*i.e.* groundings and snorkeler impact)
- Lack of moorings at popular yacht anchorages
- Poor quality, maintenance and management of existing moorings

Various efforts have been made to address these threats associated with yachting in the Grenadines, particularly within MPAs.

2.5 Mooring Systems

2.5.1 Importance of Mooring Systems

Well-maintained mooring systems within an MPA can offer a range of benefits that contribute to management success, both in terms of conservation objectives and visitor satisfaction (Fairhead and Baldwin, 2015). Moorings can reduce the use of anchors, lessening the threat of anchor damage to benthic species and habitat, notably seagrass and coral reefs (Marbà *et al.*, 2002). Reliable mooring systems can provide more assurance than anchors because anchors can drag across the seafloor, which can lead to collisions in addition to damaging the benthic communities. A study looking at the effectiveness of management measures conserve seagrass meadows in Spain's Cabrera National Park found that mooring systems can offer opportunity for seagrass meadows to recover from anchoring damage (Marbà *et al.*, 2002).

Moorings can also serve to reduce overcrowding, promote the efficient use of space, and increase boater safety and wellbeing (Diedrich *et al.*, 2013). Dive moorings can offer a

method of restricting the level of activity at popular sites. If park regulations require SCUBA divers to be accompanied by a dive master from a local dive operator, as is the case for the TCMP and SIOBMPA, dive moorings can support this regulation by reserving access for local dive operators. In areas with strong currents, dive moorings may serve to assist SCUBA divers ascents or descents by providing a guideline from the surface buoy to depth. Revenue generated from mooring fees can be managed to sustainably finance MPA expenditures, such as mooring maintenance costs or patrol vessel expenses (Hoggarth, 2007). The mooring systems may also provide opportunities to monitor and control park access (Diedrich et al., 2013). For instance, if monitoring were to indicate that the MPA's carrying capacity is being exceeded, yacht moorings could be disassembled to decrease the number of sites available for yachts to berth.

2.5.2 Yacht Mooring Systems

Mooring systems consist of three primary components, (1) a permanent fixture on the seafloor, (2) a floating buoy at the surface, and (3) a series of lines attaching the bottom fixture to the surface buoy (Breda and Gjerde, 1996). The Halas principle of mooring design, which involves an anchor and a three part rope and buoy system (Figure 2), is widely used in marine parks due to its simple construction methods and practical maintenance costs (Fairhead and Baldwin, 2015).

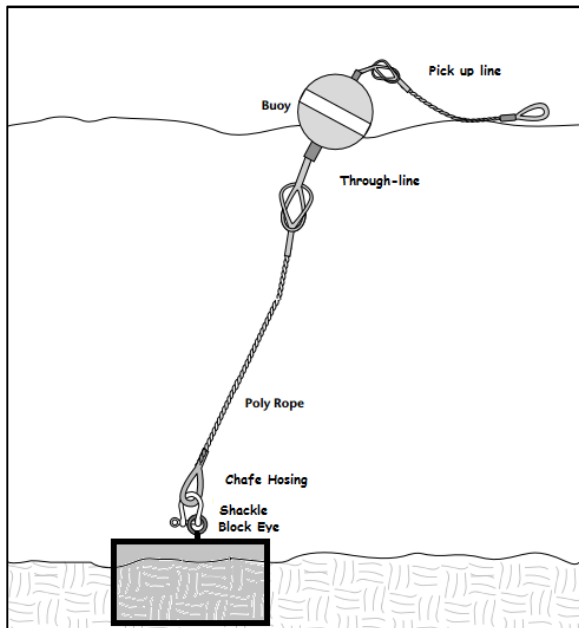

Figure 3. Typical Halas style mooring system design (Fairhead and Baldwin, 2015).

The type of mooring system anchor deployed in an area is dictated by the seafloor characteristics (Breda and Gjerde, 1996). Block-type mooring systems are best suited for areas with shallow mud, sand, or gravel and are not recommended for areas with corals or seagrass (Breda and Gjerde, 1996). Block-type mooring systems typically consist of a heavy block anchor (e.g. concrete or engine block) with an attachment chain and floating buoy (Figure 2). The block anchor is not permanently fixed to the bottom so the system should be deployed on a level bottom to avoid shifting (Breda and Gjerde, 1996). Block-type moorings are often used because other types are more expensive and require more specific materials, equipment and expertise. One of the drawbacks associated with using block-type anchors is that once the block is deployed it is difficult to move or remove. Block-type moorings also change the clearance available for boats to pass overhead so if a block is in a shallow area and not embedded in the sediment, collisions may occur (S. Carey, personal communication, July 24, 2016).

Manta and pin mooring systems utilize ‘manta ray’ embedment anchors to secure the system in areas of sand, coral rubble, or a combination of bottom-types (Figure 4). A utility anchor is driven into the seafloor (Figure 5) using a hydraulic underwater hammer.

SCUBA divers then attach the down line to a thimble eye nut that is screwed to the anchor. The thimble eye nut should be welded to the anchor to keep the system from unscrewing. Manta systems can be deployed in approximately 30 minutes or less so labour costs are minimal (Breda and Gjerde, 1996). A disadvantage of this design is that once the anchor is positioned within the substrate, it can be tremendously difficult to reposition (O. Harvey. personal communication, November 11, 2016).

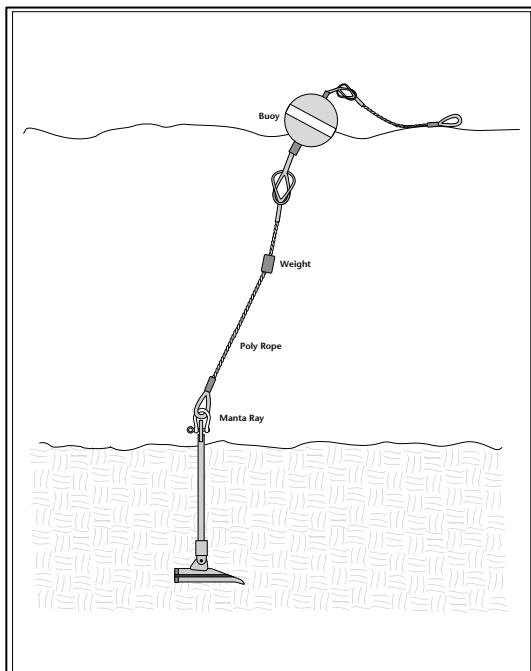

Figure 4. Manta and pin mooring system (Breda and Gjerde, 1996).

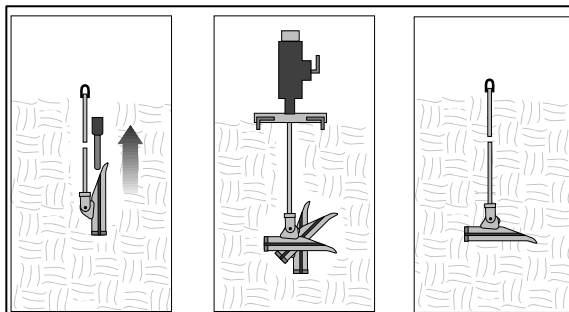

Figure 5. Manta anchor securement stages in seafloor (Breda and Gjerde, 1996).

Chapter 3: Site Descriptions

3.1 Tobago Cays Marine Park

3.1.1 Park Description

The Tobago Cays Marine Park (TCMP) encompasses approximately 66 km² of the southernmost waters of SVG. Four cays – Petit Rameau, Petit Bateau, Jamesby and Baradal – are protected by Horseshoe Reef (Figure 5). Petit Tabac, the fifth cay, is located east of the main group. The cays themselves are uninhabited, but the park boundaries encompass the island of Mayreau, which is home to 271 people (SVG, 2012). Union Island and Canouan are populated islands near to the TCMP. The Egg Reef, World's End Reef and the Mayreau Gardens are series of reefs located offshore of the islands within the TCMP.

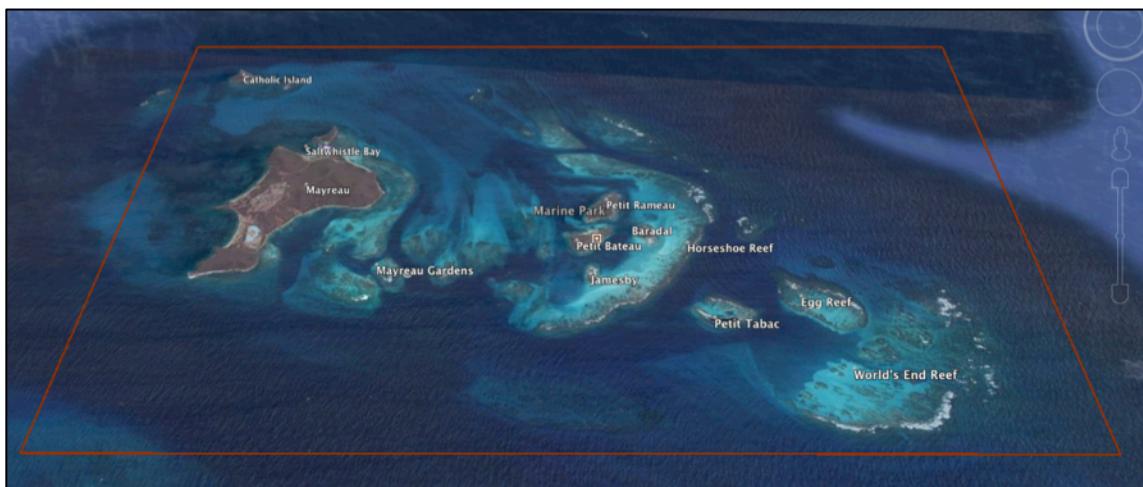

Figure 6. Map of the Tobago Cays Marine Park with boundaries (red) and labeled islands, cays and reefs (Google Earth, 2016)

The Tobago Cays are of great cultural, social, ecological and economic value to the Grenadines. The area was a designated fisheries conservation site under the 1987 Fisheries Regulations, and became the TCMP in 1997. The Tobago Cays Marine Park (TCMP) is listed as a protected area under the Specially Protected Areas and Wildlife (SPA) protocol because of its ecological and socio-economic value, including populations of threatened marine and terrestrial species and important habitats (UN, 2014). With fringing and bank-barrier coral reefs, seagrass beds that support threatened

and critically endangered turtles (i.e. Green and Hawksbill turtles), and patches of endangered mangrove ecosystem, the TCMP's significant biodiversity makes it a conservation priority (UN, 2014). Not surprisingly, the TCMP has long been a tourism hotspot (Hoggarth, 2007); thus, the area has been subject to stresses of tourism uses including yachting, SCUBA diving, water taxi and cruise transportation. Around 50,000 people visit the TCMP annually, and over 80% of yachts that visit the Grenadines visit the TCMP (UN, 2014). Management must focus on minimizing the impact of tourism on the marine resources that are the key to the park's value.

3.1.2 Management of the TCMP

The TCMP is managed under the National Parks, Rivers, and Beaches Authority of SVG in a management arrangement between the Fisheries and Forestry Divisions, and the Marine Parks Board (Hoggarth, 2007). Co-management systems are in place for certain sites or park features, giving a share of the park's management responsibilities to NGOs, such as Sustainable Grenadines Inc. (Hoggarth, 2007).

The Marine Park Authority is made up of approximately ten staff including a manager, administrative and rangers that work out of the TCMP Visitors Centre, located on Union Island. The Marine Park Authority does not rely on government subventions, but is self-financed, gaining income from visitation and mooring fees. In 2014, the estimated annual income and expenditure for the TCMP was \$630, 000 East Caribbean Dollars (XCD; UN, 2014). Approximately half of the expenditure was spent on staff salaries, while the remainder was spent on expenses including fuel and maintenance (UN, 2014).

3.2 Sandy Island Oyster Bed Marine Protected Area

3.2.1 MPA Description

The Sandy Island/Oyster Bed Marine Protected Area (SIOBMPA) is located on the southwest coast of Carriacou (12° 27.878'N, 61° 29.573'W), the largest of the Grenadine islands in Grenada (Figure 5). Approximately 8,000 residents inhabit the volcanic island. The majority of local livelihoods rely on the tourism or fisheries sectors. The primary

activities that occur within the SIOBMPA are spear fishing, pot fishing, seine fishing, SCUBA diving, recreational use, water taxi use and charter craft usage (MCMPPA, 2015). The SIOBMPA boundaries encompass the mangroves of Lauriston Pt. in Hillsborough Bay, the shoreline through L'Esterre Bay, Pt. Cistern, and the north end of Tyrrel Bay (Figure 5). Islands within the MPA include Sandy Island, Mabouya Island, and the Sister Rocks (Figure 5).

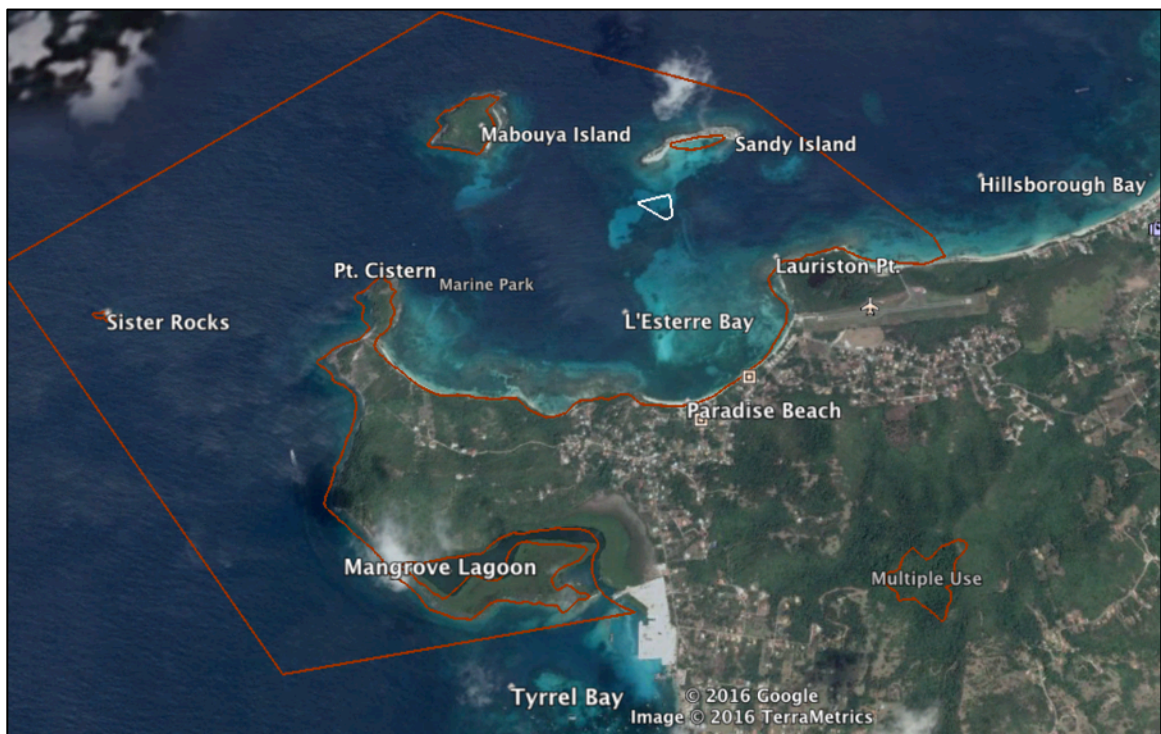

Figure 7. Map showing the MPA boundary (red) of the SIOBMPA, Carriacou, Grenada (Google Earth, 2016).

The SIOBMPA is the largest and most biologically diverse MPA in the state of Grenada (MCMPPA, 2015). Covering 6.59 km², the MPA has extensive reef development, mangroves, and seagrass beds. Several coral reef systems provide habitat for numerous species, offer coastal protection from high-energy waves and currents, and attract SCUBA dive and snorkel tourism to the MPA. With its postcard-ready white sandy beaches and turquoise waters, Sandy Island is a significant site that attracts locals and tourists to the MPA. Tourists SCUBA diving and snorkelling frequent coral reef systems off of Sister Rocks and Mabouya Island. The mangroves within the MPA are also

significant, contributing a number of ecosystem goods and services including land-based sediment filtration, coastal protection and breeding grounds and nurseries for fish and shellfish (Moore, 2014). Along the north side of Tyrrel Bay, a dominant stand of Red Mangroves (*Rhizophora mangle*) serve as habitat for the Mangrove Oyster (*Crassostrea rhizophorae*), the Flat Tree Oyster (*Isognomon alatas*) and the Grenadian Bank Tree Boas (*Corallus grenadensis*; Moore, 2014). The tree boas are endemic to Grenada Bank (TNC GFD, 2007). A lagoon within the mangroves offers a safe haven for boats during tropical storms (TNC GFD, 2007).

3.2.2 Management of the SIOBMPA

The Nature Conservancy (TNC) developed a Draft Management Plan for the SIOBMPA in 2007. The management plan was developed in a participatory process that included a wide range of stakeholders (i.e. community members, government representatives, scientists) (Harvey and Baldeo, 2013). TNC and the government of Grenada have a Memorandum of Understanding to work towards the implementation of the Programme of Work on protected areas in Grenada, hence TNC's ongoing support of the SIOBMPA. After the signing of a co-management agreement, the MPA was officially launched in July 2010. Co-management of the MPA was identified as the most appropriate management mechanism since the stakeholders and government agencies 'on the ground' were considered to have a better understanding of the context of the area (Harvey and Baldeo, 2013). It was anticipated that co-management could improve responsiveness and adaptability of the management interventions to evolving social and ecological conditions. Educational activities aimed at increasing local awareness regarding the intentions and associated opportunities of the MPA have been ongoing within the communities of Carriacou for over a decade.

The Fisheries Division of the Ministry of Agriculture, Lands, Forestry and Fisheries through the Grenada Marine Protected Area (GMPA) Program is the main government agency responsible for the management of the SIOBMPA, as well as all other MPAs in

Grenada. Under the auspices of the National MPA Committee and MPA Coordinator, a Stakeholders Board co-manages the SIOBMPA (Whyte, 2012).

The Ministry of Carriacou and Petite Martinique Affairs (MCPM) play a clearinghouse role, employing four park wardens, two of which are trainees, and supporting patrol boat services and maintenance (Whyte, 2012). Currently, there is not an MPA manager for the SIOBMPA. A fisheries officer has been responsible for the MPA's managerial tasks in the interim between MPA managers.

The 2007 SIOBMPA Draft Management Plan was revised in 2015 through collaboration between The Ministry of Carriacou and Petite Martinique Affairs, The Gulf and Caribbean Fisheries Institute (GCFO), TNC, and the SIOBMPA Management Committee. The revised plan calls for better integrated management and operational planning.

The SIOBMPA is a founding member of the Grenadines Network of MPAs, which was established in 2011 to promote coordination and collaboration amongst MPAs in Grenada and SVG. Along with other member MPAs, the SIOBMPA has been involved in meetings, training, learning exchanges and monitoring expeditions that are coordinated by Sustainable Grenadines Inc. (SusGren).

Chapter 4: Research Strategy

4.1 Threat Assessment of Yachts to the TCMP and SIOBMPA

In order to determine the potential threats posed by yachts that the AMMP should address, information was drawn from the management plans of each MPA, the management staff, and in-water observations made during the field surveys. A summary table was created to present the main findings. Based on this information and a literature review, a DPSIR framework was created to outline the aspects associated with managing yachting threats within the MPAs via mooring management. The DPSIR framework

aimed to highlight the linkages and feedbacks between the causes and effects of impacts of yachting activities on MPAs, with a specific focus on the potential for a mooring management strategy to better understand and mitigate the impacts. Through the application of the DPSIR methodology, indicators that could facilitate effectiveness monitoring were identified. The evaluation of these indicators could inform decision-making and instigate adaptations to management actions to promote efficiency.

4.2 Management Review

4.2.1 Management Review of the TCMP

The TCMP management plan was assessed to determine what conservation objectives and supporting activities were relevant to consider within this management plan. Discussions with park management staff provided insight on the current mooring management practices and suggestions for future mooring management.

4.2.2 Management Review of SIOBMPA

The SIOBMPA management plans, both the original and the version revised in 2015, were assessed to identify relevant conservation objectives and supporting activities. Discussions with park management staff provided insight on the current mooring management practices and suggestions for future mooring management. In 2007, Moor Seacure International Ltd. developed a Mooring Feasibility Report for SIOBMPA (Moir, 2007). The report was examined for technical advice, including mooring system and site recommendations. A report on the installation of the yacht and demarcation buoy moorings for the SIOBMPA provided information on site characteristics and installation procedures (Laflamme, 2010).

Grenada's legislation was reviewed in order to identify relevant policies and determine the capacity for MPA regulations to be legally enforced. Relevant international agreements that Grenada has committed to were reviewed to reveal opportunities for recommended management measures to support such commitments.

4.3 Field Surveys

Field assessments of the existing mooring systems in SIOBMPA and the TCMP were conducted to gather baseline data to inform the proposed management recommendations. Yacht moorings and small boat moorings were included in the field survey. Dive moorings were not included in the field survey because their current condition and GPS locations were known. In addition, an inspection of the dive moorings would have required the inspector to SCUBA dive, which would have increased project costs. A snorkeler inspected all of the yacht and small boat mooring systems within the MPAs' boundaries. MPA rangers/wardens in the MPA patrol boats assisted the snorkeler. Once a mooring system was located, the snorkeler free dove to check all of the mooring system's components. The depth was measured with a measuring tape that the snorkeler unwound until the weighted end reached the seafloor next to the mooring anchor. The observations were called out to one of the wardens, who recorded the data in a field notebook. The warden also used a GPS to determine the mooring systems' locations. The snorkeler took photographs to document standard and abnormal features of the mooring systems and seafloor.

The recorded data were transcribed into an excel worksheet, creating a mooring systems database for each MPA. Google Earth was used to map the locations of the surveyed moorings.

4.4 Visitation Data

The park management staff provided available visitation and mooring data. The data requested included the following:

- Number of yachts that visit the park
- Number of people aboard the yachts
- How many yachts have used the available moorings
- Number of days spent on the mooring

- How many yachts have been charged for breaking park regulations, specially anchoring in no-anchoring areas and flushing holding tanks

Visitation data for the TCMP were obtained for the years 2009-2015. The average number of persons per yacht was calculated. Mooring fee records were available for the past two years. These records were transcribed into an Excel spreadsheet, providing the figures on the number of moorings used and the number of days spent on each mooring. The average number of days spent on a mooring was calculated for the two years of data. A warden transcribed the SIOBMPA mooring fee records into an Excel spreadsheet, providing the figures on the number of moorings used and the number of days spent on each mooring. Mooring fee records were only available for 2014 and 2015. Since the mooring fees are higher for boats over 50 feet in length, it was possible to determine the percent of boats that overnighted in SIOBMPA that were over 50 feet in length.

4.5 Site Selection for New Mooring Installations

4.5.1 Siting Moorings in the TCMP:

There was a need to strategically site the locations of additional mooring fields. The rangers responsible for mooring system management in the park were asked to identify zones where new moorings could be installed. Within these zones, mooring sites were identified based on a number of factors.

The mooring sites were selected to ensure the environmental impacts of the mooring activities are as minimal as possible. Characteristics of potential sites were assessed, including bottom type, proximity to key habitats, depth and prevailing current direction. The Grenadines Marine Resource Space-use Information System (MarSIS) data layers were uploaded to Google Earth in order to visualize the locations of shallow water habitats. Habitat layers from the CaribNode database were also downloaded and visualized in Google Earth (<http://www.caribnode.org/layers/>). Nautical charts

(<https://webapp.navionics.com/#@12&key=stblAdiouJ>) were used to gather data on the depths and prevailing currents of the identified zones.

When selecting locations for additional moorings, boat safety and user satisfaction must also be considered. Overcrowding has been reported to decrease safety and user satisfaction, and thus, adequate spacing of moorings and a set capacity within anchoring zones are very important aims to achieve. Literature was reviewed to determine the recommended spacing of mooring systems within a mooring field, which depends on the size of the boat. A distance of 130 feet was deemed appropriate because if boats up to 65 feet use the moorings, there is at least double the length of the boat between moorings to allow for swing room. Using the Google Earth map with the current yacht, small boat and dive moorings marked, the ruler tool was used to identify yacht mooring sites at least 130 feet from any moorings or other obstructions. The same spacing protocol was used for small boat moorings, with at least 50 feet between each site.

The proximity to MPA features of interest was considered. For instance, the turtle watching reserve surrounding Baradal is one of the key tourist attractions of the MPA, and therefore, moorings located nearby would likely entice boaters more than moorings elsewhere. It is important to take user desirability into account in order to encourage boats to berth, and thus pay mooring fees, within the MPA instead of at nearby locations outside of the MPA boundaries.

4.5.2 Siting New Moorings in SIOBMPA

The locations for new yacht mooring sites within SIOBMPA were selected following the same methods as were used for the TCMP. Additionally, the Mooring Feasibility Report developed for the SIOBMPA by Moor Seacure International Ltd. was used to gain information on the seafloor suitability of the sites identified as potential locations for the installation of additional mooring systems (Moir, 2007).

The proximity to MPA features of interest was also considered when determining where to site new yacht and small boat moorings. The features of interest considered included Sandy Island, Paradise Beach and the mangrove lagoon off of Tyrrell Bay, which are key tourist sites within the MPA.

New sites for dive boat moorings were selected based on recommendations made by the three dive operators that use the MPA. GPS coordinates were provided for the suggested sites (R. Laflamme, personal communication, July 6, 2016).

Chapter 5: Results

5.1 Identified threats of Yachts to the TCMP and SIOBMPA

The potential threats posed by yachts that the AMMP should address were identified (Table 1). Based on multiple sources, it was determined that anchoring poses significant threats to the TCMP and SIOBMPA. Sewage pollution was also identified as one of the most significant threat of yachts, as improper holding tank disposal or a lack of a holding tank leads to untreated sewage being directly discharged into the MPAs' waters.

Table 1. Table showing potential threats associated with yachts in the TCMP and SIOBMPA.

Threat	MPA	Identified in Management Plans	Highlighted by Management Staff	Observed During Field Survey
Improper sewage waste disposal	SIOBMPA	<input checked="" type="checkbox"/>	<input checked="" type="checkbox"/>	<input checked="" type="checkbox"/> *green algal bloom off of Paradise Beach suggesting nutrient pollution (Appendix B, Figure 34)
	TCMP	<input checked="" type="checkbox"/>	<input checked="" type="checkbox"/>	
Anchoring	SIOBMPA	<input checked="" type="checkbox"/>	<input checked="" type="checkbox"/>	-
	TCMP	<input checked="" type="checkbox"/>	<input checked="" type="checkbox"/>	<input checked="" type="checkbox"/> *anchor in seagrass, uprooting and breaking stems (Appendix B, Figure 37,38)
Mooring lines without floats	SIOBMPA	-	<input checked="" type="checkbox"/>	<input checked="" type="checkbox"/> *no scouring of seagrass observed but lack of floats suggests risk
	TCMP	-	<input checked="" type="checkbox"/>	<input checked="" type="checkbox"/> *line on seabed with scoured seagrass surrounding mooring anchor (Appendix B, Figure 35)
Coral damage by snorkelers/divers	SIOBMPA	<input checked="" type="checkbox"/>	-	-
	TCMP	<input checked="" type="checkbox"/>	-	-
Overcrowding	SIOBMPA	<input checked="" type="checkbox"/>	-	-
	TCMP	<input checked="" type="checkbox"/>	-	-

5.2 DPSIR Framework for Yachting Tourism Management

The development of a DPSIR framework allowed for the assessment of the linkages between yachting tourism, its socio-economic and environmental implications, and management responses within the MPAs (Figure 8).

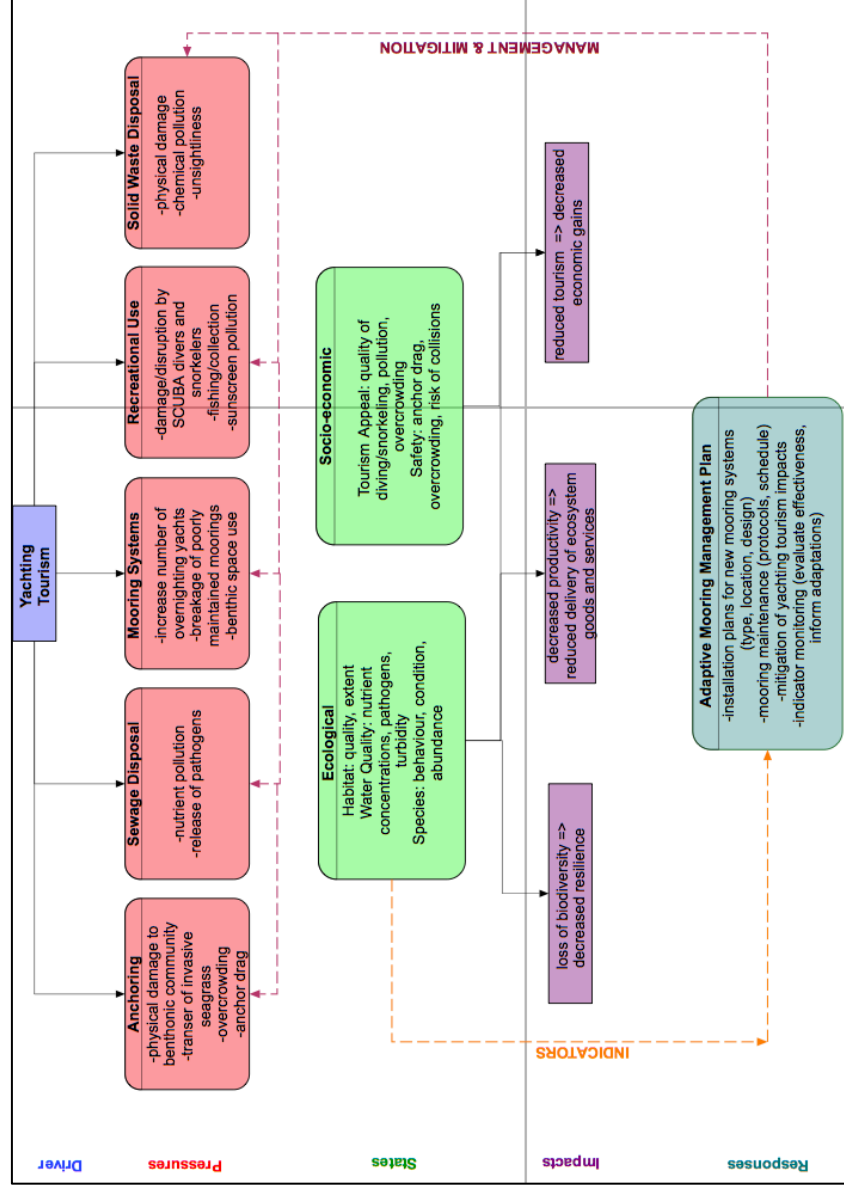

Figure 8. Diagram showing a DPSIR framework that defines aspects of yachting tourism impact management in MPA

Driver:

Yachting tourism was identified as the driver of focus for the DPSIR framework. The yachting tourism sector provides significant economic benefits to the region, providing employment and generating revenue (Baldwin et al., 2016). Yachting tourism is significant to the MPAs because the visitation and mooring fees generate revenue that is used to pay MPA staff, maintain park infrastructure (e.g. mooring systems), and support management actions (Hoggarth, 2007; TNC GFD, 2007). The responses recommended to mitigate the pressures, therefore, were designed with consideration as to how they will impact the yachting tourism's economic benefits to the MPAs, and more broadly, to the region. Management actions that aim to minimize the threats associated with yachts can help ensure that the tourism appeal of the MPAs is not compromised by the tourism use. At the same time, mitigation strategies have the potential to deter yachting tourism if increased costs or restrictions are not well met. It is therefore critical to ensure that awareness is generated regarding the importance of regulations or restrictions to protecting the marine ecosystems that are attracting the tourism and its associated benefits to the region.

Pressures:

Anchoring and improper sewage waste disposal are the primary pressures of yachting tourism to the MPAs and are thus the main focus of the management and mitigation efforts detailed in the AMMPs. Still warranting consideration are the pressures associated with a more extensive system of moorings; recreational use of the MPA; and solid waste pollution.

State Changes:

The state changes that could occur as a result of these pressures were determined to be both ecological and socio-economic. Benthic habitat degradation and reduced water quality. The impacts of these state changes were predicted to be a decrease in ecosystem goods and services provided by the MPA, and a loss of biodiversity that could decrease the resilience of the ecosystems within the MPA.

Responses:

The appropriate response to mitigate the identified pressures was deemed to be the application of an adaptive management plan specific to each MPA. The installation of new mooring systems will aim to reduce the pressures of anchoring to the MPAs. Chapter 6 details the recommendations on the management and maintenance of the moorings, as well as strategies to mitigate the identified pressures of yachting tourism to MPAs.

Indicators and Management Adaptations:

Indicators focused on monitoring the state changes will assist in evaluating the effectiveness of the implemented management and mitigation strategies. If indicator-monitoring results demonstrate that the prescribed mooring management measures are not effectively mitigating the pressures associated with yachting, the management actions must be adapted in an effort to increase efficiency. It was determined that, given the limited resources of the MPAs, water quality would be the most feasible state change to monitor. Water quality could therefore be used as an indicator of the effectiveness of the waste mitigation strategies, informing management adaptations if necessary. Visitation records including data on vessel size, number of passengers, length of stay, whether they moored or anchored, and the presence and dimensions of holding tanks should be kept and used as an indicator. These records would provide data on the levels of yachting pressures, as well as highlight any changes in visitation that may be associated with altered tourism appeal.

5.3 Management Review

5.3.1 Policies Supporting Mooring Management in TCMP

The TCMP 2007-2009 Management Plan stipulates that anchoring is prohibited unless the boat is within a designated anchorage zone (Figure 10; Hoggarth, 2007). In practice, this regulation is not enforced (K. Williams, personal communication, May 27, 2016). In fact, anchoring and moorings within the TCMP have historically been controversial subjects (Hoggarth, 2007). Moorings can limit access and raise revenue, but some argue that the park should be left as natural a state as possible and do not recognize the threats

associated with anchoring (K. Williams, personal communication, May 27, 2016). In addition, some sailors prefer to anchor instead of tie to mooring systems because of a lack of confidence in the condition and reliability of moorings (B. Wilson, personal communication, July 11, 2016). Small cruise ships and yachts too large to safely use the moorings are meant to anchor in the designated anchoring zone (Hoggarth, 2007). The management plan also stipulates that maintenance costs of the moorings should be covered by profits gained from mooring fees (Hoggarth, 2007).

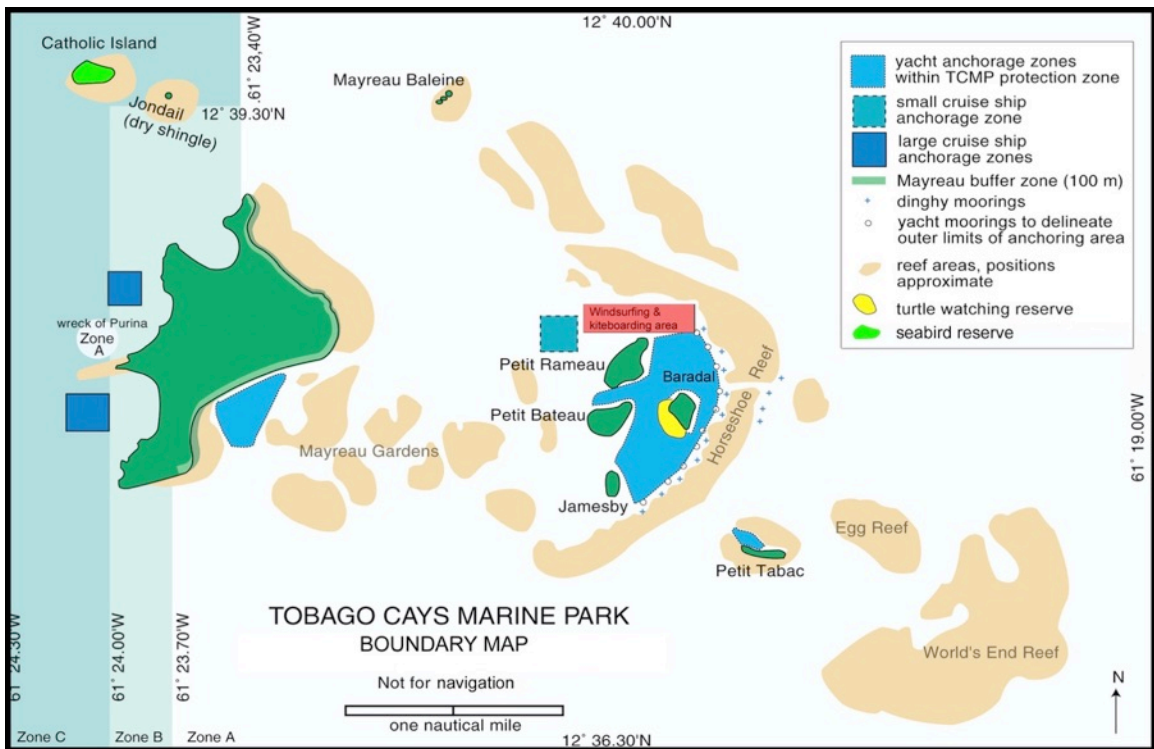

Figure 8. Tobago Cays Marine Park map showing anchorage zones, mooring fields, park boundaries, reef areas and wildlife reserves (TCMP.org).

5.3.2 TCMP Mooring Management Operations

Park Rangers collect mooring fees during daily patrols. Yachters pay mooring fees (45 East Caribbean Dollars/ 24 hours) for the use of yacht moorings in addition to park visitation fees (10 XCD/day/person). Yachters that stay more than three nights in the park receive the fourth night for free (B. Wilson, personal communication, July 11, 2016). The 2007-2009 Management Plan proposes that yachts should not be charged an anchorage fee if they anchor within the designated anchorage zone. The mooring fee records suggest

that yachts that anchor are not charged the mooring fee. It is thought that rangers have not been collecting mooring fees from anchored yachts, even if they are outside of the anchorage zone. TCMP staff and Sustainable Grenadines Inc. have been trying to gain approval to raise the park entry fees, as well as the mooring fees. It is planned that, with guidance from this management plan, more moorings systems (20-25) will be installed after the Atlantic hurricane season finishes. Existing mooring systems are a combination of manta and pin type moorings and concrete block-type moorings. A TCMP Ranger reported that the manta and pin type moorings have been unscrewing as sand shifts, and the concrete blocks are proving more appropriate for the dynamic substrate (B.Wilson, personal communication, May 27, 2016). The moorings being installed are therefore, concrete block-type moorings.

5.3.3 Policies Supporting Mooring Management in SIOBMPA

Grenada's national MPA legislation (The Grenada 2001 Fisheries (MPA) Regulations) prohibits anchoring within MPA boundaries unless there is a designated anchoring zone. Mooring systems are therefore required to provide boats with berthing options within the SIOBMPA, which only has a small anchorage zone. Prohibiting the use of anchors within the MPA, besides within the anchoring zone, aims to eliminate the threat of anchors causing damage to coral reefs and seagrass beds. The health of these key ecosystems is essential if the biodiversity of the area is to be conserved. In fact, stakeholders involved in developing the MPA's original management plan identified seagrass beds and coral reef ecosystems as two of the seven key resources that the SIOBMPA should serve to protect (TNC GFD, 2007). Damaging anchoring practices could indirectly impact sea turtles and livelihood security, which were also deemed key resources by MPA stakeholders. For instance, damage to coral reefs or seagrass beds could decrease the quality of habitat available to support commercially fished species, lessening the benefits of the MPA to the region's fishers. Since green turtles rely on seagrass beds for nutrition, a reduction in seagrass cover or quality could negatively impact green turtles, which are the most frequently observed species of sea turtles in the region, are culturally significant, and are an important tourism draw.

Mooring systems were also considered as an approach to reduce pressures on mangroves

during storm events wherein boaters seek shelter in the mangrove lagoon and tie their lines.

A number of the MPA objectives that are included in the original management plan for the SIOBMPA are relevant to this study (TNC GIF, 2007). Objective 7 is “to eliminate boat anchoring in seagrass beds, mangroves and coral reefs in the Park within one year” (TNC GFD, 2007). Objective 9 – “to regulate the number of vessels visiting Sandy Island at one time, based on carrying capacity within one year” – will be supported by the Strategic Actions of Objective 7. The strategic actions are as follows:

- Develop a mooring buoy program within the MPA that targets seagrass beds, mangroves and coral reefs using public consultation.
- Implement mooring buoy program within the Park.
- Establish regulations for anchoring within mangrove areas in the Park during emergencies.
- Develop and implement a public awareness campaign for the general public and targeted groups (fishermen, schools, beach vendors, boaters, etc.)

The revised management plan, which was submitted for MPA board approval in June 2016, highlights high priority and low priority actions that have not been achieved. One of the identified high priority actions was to “maintain mooring buoys” through the implementation of adaptive management techniques. It was suggested that patrol guidelines be developed and that rangers be granted authority to issue tickets, notably for improper sewage disposal. Lower priority actions included the establishment a park monitoring protocol before operation of MPA (re. sewage disposal); the implementation of national legislation (re. sewage disposal); and establish regulations for anchoring within mangrove areas in the Park during emergencies.

5.3.4 History of Moorings at SIOBMPA

In 2009, Moor Seacure International completed onsite visits and underwater inspections together with seabed probes in order to determine the type and suitability of the seabed and make recommendations for the appropriate design of moorings for each area (Moir,

2009). The recommended sites do not currently have moorings and are too close to existing moorings to use as sites for additional installations. In 2010, a mooring systems installation project saw 25 yacht moorings of the manta ray type installed near Sandy Island. This brought the park closer to achieving Objective 7, as described above. Many of the moorings, however, were eventually removed or redone because of insufficient spacing, improper splicing, and incorrect lengths of pickup lines. The current moorings were installed in 2015 through a CARIBSAVE project. This history of mooring installations emphasizes the need to follow a well-informed plan for new mooring installations.

5.3.5 SIOBMPA Mooring Management Operations

Yachts up to 50 tons are permitted to use the existing moorings. When the wind reaches over 16 knots, however, yachts must be under 40 tons to use the moorings. If the yacht is too large to safely use the mooring system, the yacht must use an anchor within the anchorage zone. From Sunday to Friday, a park patrol boat collects moorings fees in the morning. Yachts under 50 feet in length pay 27 Eastern Caribbean Dollars (XCD) or \$10 USD for 24 hours. Yachts over 50 feet pay 50 XCD or \$20 USD for 24 hours. The same fees apply to yachts anchoring within the designated anchoring zone. Charter yacht boats are also charged a snorkeling fee of \$1 USD per person. Park wardens do not work on Saturdays so mooring or snorkeling fees are not collected. Water taxi operators (WTO) are not currently charged mooring fees. Dive operators using the moorings within the MPA do not pay mooring fee but \$2 USD per diver; the potential for an annual user fee has been discussed, but never tabled.

5.4 Field Surveys

5.4.1 Field Survey Results of Moorings in the TCMF

The snorkeler assessed all of the mooring systems within the TCMF, which included 53 yacht mooring systems. Eight mooring systems had manta and pin anchors, while the other 45 mooring systems had concrete-block anchors. Nine of the moorings were missing buoys or other components that rendered them unusable; three of these mooring systems had manta and pin anchors and were purposefully not maintained for use because

the rangers did not trust the anchors due to shifts in position within the sandy bottom. Photographs taken to document standard and abnormal features of the mooring systems and seafloor are included in Appendix B. The existing yacht mooring sites surrounding the cays are shown in Figure 11. The existing yacht mooring sites within Salt Whistle Bay of Mayreau are displayed in Figure 12.



Figure 9. Map showing locations of existing yacht moorings (black and white rings) near Baradal (top right), between Petit Bateau and Petit Rameau (top left) and east of Jamesby (bottom left), RCMP (Google Earth, 2016).

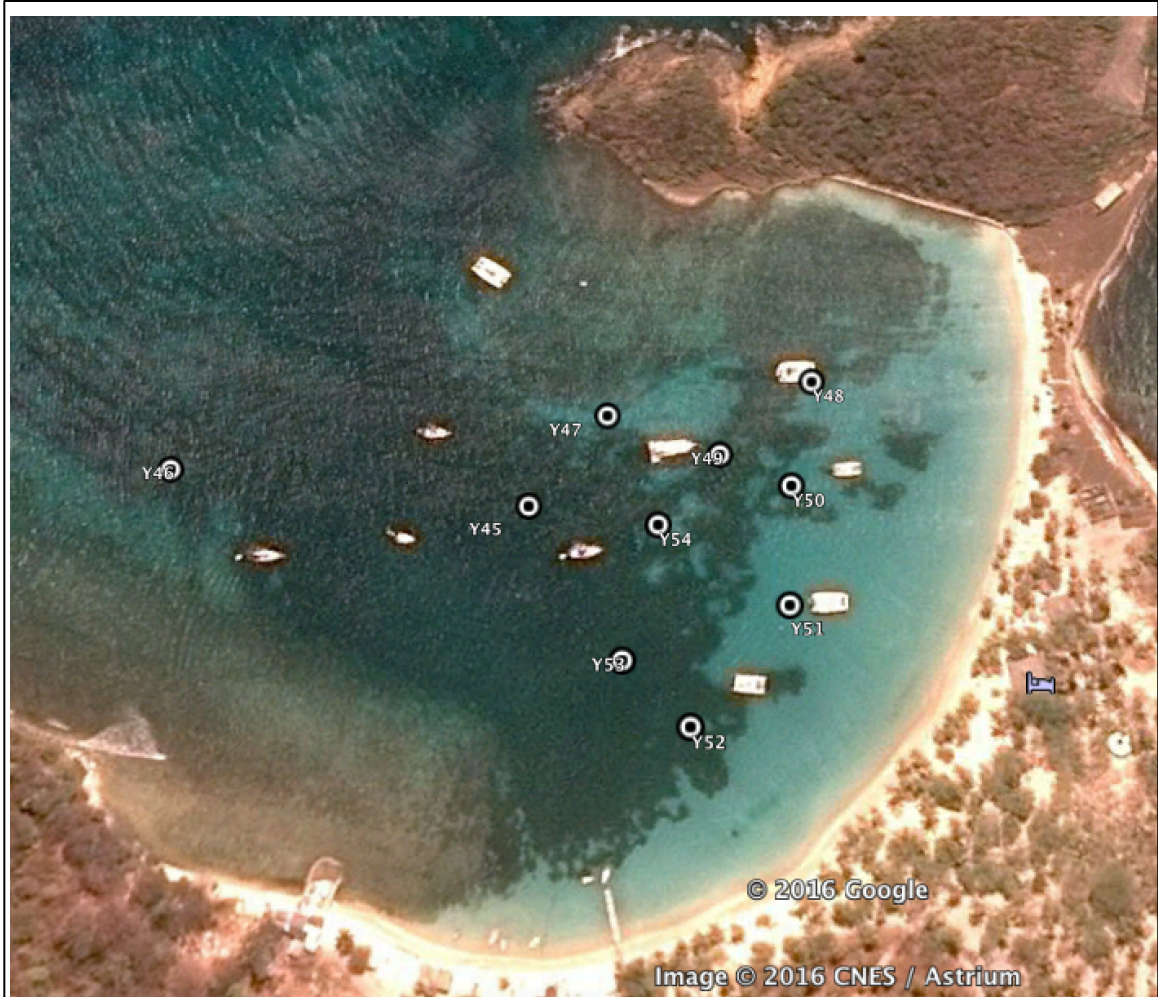

Figure 10. Map showing locations of existing yacht moorings (black and white rings) within Salt Whistle Bay off of Mayreau, TCMP (Google Earth, 2016).

5.4.2 Field Survey Results of Moorings in SIOBMPA

The snorkeler assessed a total of 17 yacht mooring systems within SIOBMPA, covering all of the existing mooring systems or partial mooring systems (i.e. anchors missing lines). Two of the moorings were missing buoys or other components that rendered them unusable. Twelve yacht moorings south of Sandy Island were examined and mapped (Figure 13). Five yacht moorings and six small boat moorings were assessed near Paradise Beach in L’Esterre Bay (Figure 14). The yacht moorings have manta and pin style anchors and are in sandy patches amongst seagrass and corals. Photographs taken to document standard and abnormal features of the mooring systems and seafloor are included in Appendix B to clarify observations noted during the assessments.



Figure 11 Current overnight yacht moorings located south of Sandy Island, SIOBMPA (Google Earth, 2016).

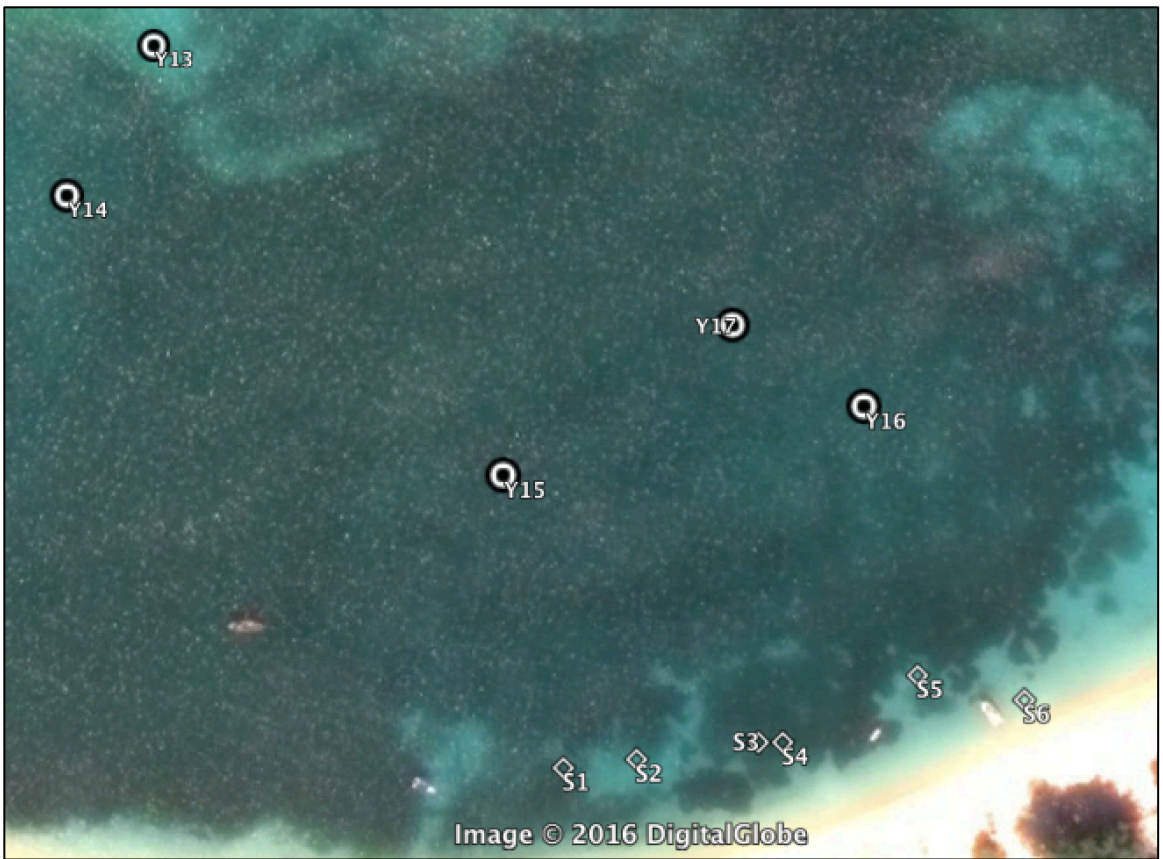

Figure 12 Current overnight yacht moorings (black and white rings) and small boat moorings (white diamonds) off of Paradise Beach, L'Esterre Bay, SIOBMPA, Carriacou (Google Earth, 2016).

5.5 MPA Visitation and Mooring Fee Records

5.5.1 TCMP Visitation and Mooring Fee Records

Available mooring fee records were assessed to look at the number of boats overnighing in the park, both in 2014 and in 2015. The park records indicate that the number of yachts that visited the TCMP each year from 2009 to 2015 ranged from 7,773 to 8,636 (Figure 15). The number of passengers aboard these yachts ranged from 42,644 to 50,076 (Figure 15). The average number of passengers per yacht was calculated to be 5.55.

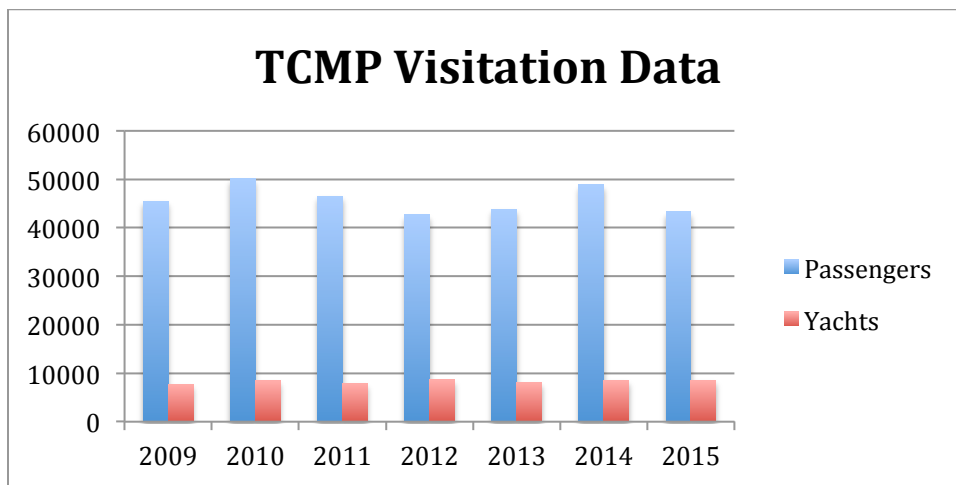

Figure 13 Graph showing the number of yachts and passengers that visited the TCMP from 2009 to 2015.

Mooring fee records indicated that 2,001 and 2,196 yachts used moorings in 2014 and 2015 respectively. Comparing this to the number of yachts recorded in the visitation records, it was determined that only about 1/4 of the yachts paid mooring fees. It is important to note the there is no record of the number of moorings available for each year, which may have impacted the amount of boats overnighing in the MPA.

In these two years, only 263 yachts stayed for 2 nights, 8 stayed for 3 nights and 1 stayed for 4 nights. These results indicate that 93.53% of yachts mooring in the TCMP spend only one night.

There were no records of any fines issued for breaking the no-anchoring regulation that applies to everywhere within park boundaries except for designated anchoring zones. The

TCMP manager confirmed that there has never been a charge pressed for breaking the no-anchoring regulation (K. Williams, personal communications, May 27, 2016).

5.5.2 SIOBMPA Visitation and Mooring Fee Records

The mooring fee records were assessed to determine the number of boats overnighing in the park each month. Since mooring fees for SIOBMPA are collected whether the boats anchor or use the mooring, data from mooring receipts indicates how many boats overnighed in the MPA. The data does not indicate whether the boats moored or anchored. Receipts were available to indicate the number of boats that overnighed each month of 2014, except for June through September (Figure 16), and each month of 2015 (Figure 17). There is no data available for these months because the MPA patrol boat was not operating, and thus, mooring fees were not collected. Records from the eight months of 2014 in which fees were being collected indicate a total of 619 boats overnighed in the SIOBMPA. January and February were the busiest months of 2014, with 120 and 134 boats per month respectively. March and December were the busiest months of 2015, with 140 and 133 boaters per month respectively. Comparing the eight months of data from 2014 with the data from the same eight months of 2015 shows an 18.70% increase in the number of boats overnighing in the MPA.

Since there is a higher fee for boats greater than 50 feet in length, the data showed the size class of the boats. The mooring fee records for 2014 indicate that 91.76% of the boats that paid the mooring fee were less than 50 feet in length. In 2015, mooring fee records indicate that 89.99% of the boats that paid the mooring fee were less than 50 feet in length.

It is important to note the there is no record of the number of moorings available for each month, which may have impacted the amount of boats overnighing in the MPA. There is also no indication of the number of days the wardens collected mooring fees so the unit effort is not accounted for in these results.

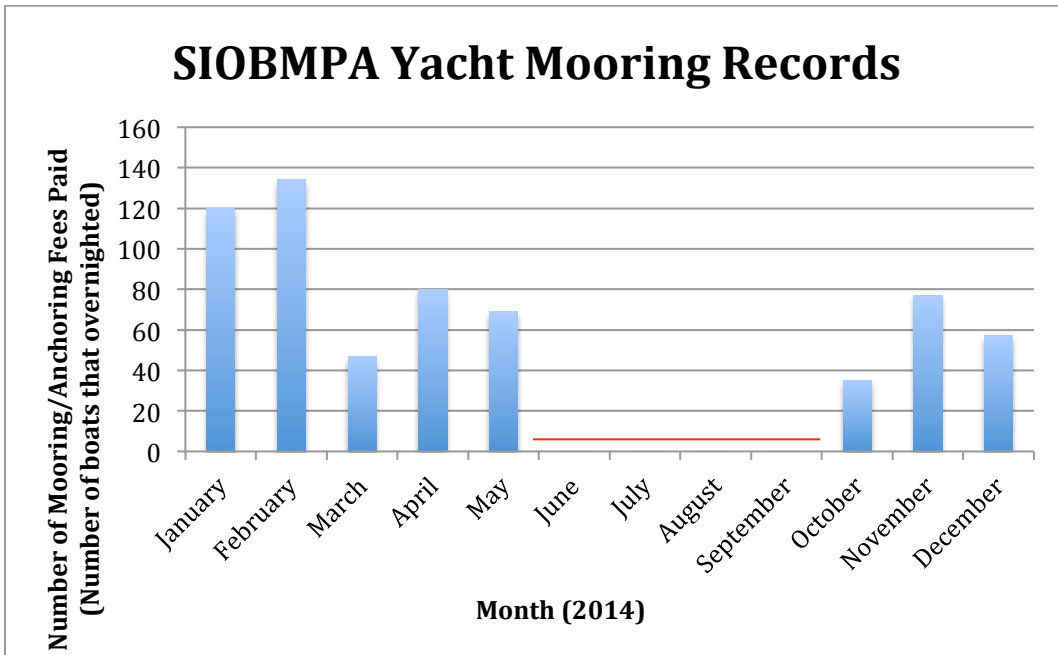

Figure 14. Graph showing number of boats that overnights in SIOBMPA for each month in 2014, except for June-September when the patrol boat was out of service (red line).

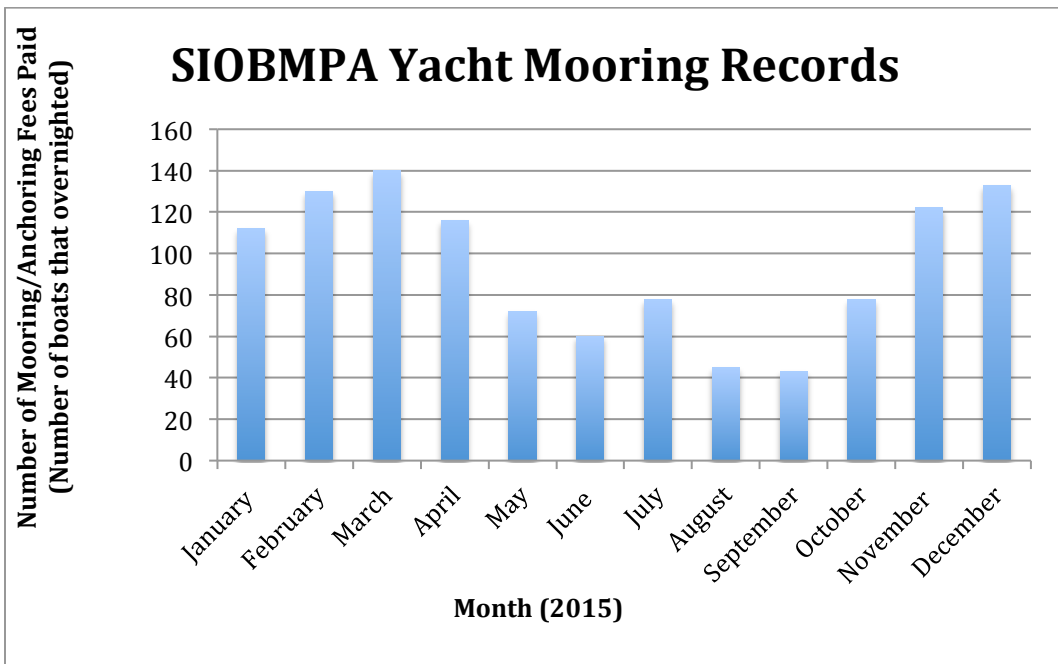

Figure 15. Graph showing number of boats that overnights in SIOBMPA each month in 2015.

5.6 Potential Sites for New Mooring Installations

5.6.1 Yacht Moorings in the TCMP

The TCMP rangers currently responsible for mooring system management in the park identified zones where there is potential for new moorings to be installed, as shown in Figure 18.



Figure 16. Zones with potential for new mooring installations (pink polygons) and current yacht mooring sites (black and white rings; GoogleEarth, 2016).

Within the identified zones, twenty-two sites have been identified as potentially suitable for the addition of new yacht mooring systems. These sites do not conflict with the current mooring systems as they are a minimum of 130 feet from any existing mooring system and so can accommodate yachts up to 65 feet. Figure 19 displays their locations as well as the existing mooring systems near the cays (See Appendix A for a summary of the recommended mooring sites' features).

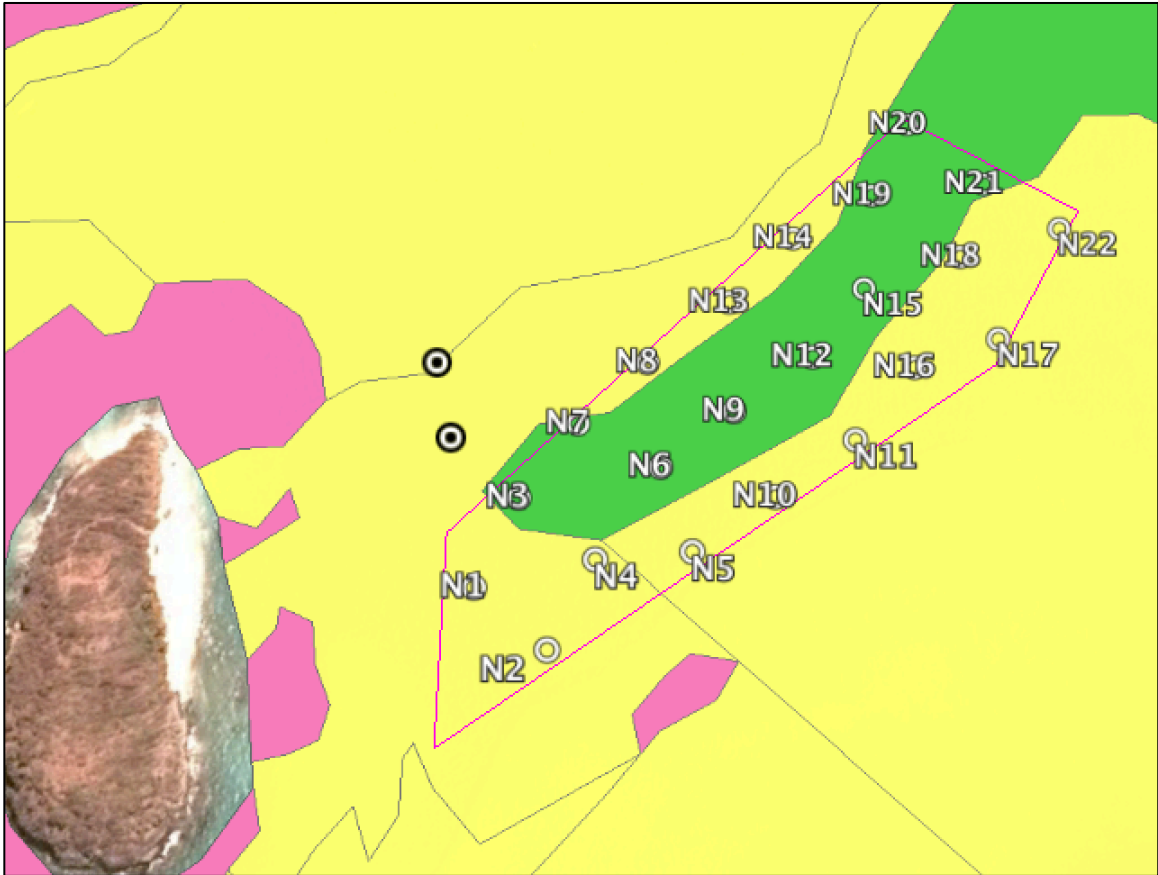

Figure 17. Map showing locations of current yacht moorings (black and white rings) and the potential sites for new yacht moorings (white rings) northeast of Jamesby, TCMF. MarSIS habitat layers show areas dominated by sand in yellow, seagrass in green and coral in pink (GoogleEarth, 2016).

Note that the MarSIS habitat data layers indicate the presence of seagrass within the zone recommended for new yacht mooring systems (Figure 19). Based on in-water observations, it was concluded that the seagrass occurs in patches on the sandy bottom and thus, the mooring systems can be deployed in sandy areas so as not to damage seagrass meadows. The surrounding areas wherein the MarSIS habitat layer indicates a large expanse of sand were not selected for new moorings because of inappropriate depths and slopes. The dynamic conditions of the sand were also taken into account, as sand drifts accumulate in some areas between the cays at heights that could cover the mooring anchors and affect their maintenance and condition. The presence of seagrass suggests that shifting sand is not drifting and accumulating in the zone identified for new yacht moorings.

It is recommended that no yacht moorings be installed in the zone north of Petit Tabac. A number of reasons influenced this decision. Firstly, the water depth is relatively shallow and patches of reef surround much of the island so not many yachts could be accommodated. Installing yacht moorings would likely increase the amount of yacht traffic in the area, which could lead to more incidences of boats colliding with the reef. Additionally, the waters surrounding Petit Tabac can become too rough to safely moor overnight when the wind is strong. Petit Tabac is also isolated from the other cays, so water quality monitoring results from this site can be compared to the results from sites where yachts overnight to gain a better understanding of the yachts' impact on water quality.

5.6.2 Small Boat Moorings in the TCMP

Currently, small boats anchor, drive back and forth between yachts and islands or reefs, or are grounded and tied to trees. Small boat anchors can cause damage to benthic habitat and species via anchoring. Dinghies driving back and forth between boats and the islands or reefs release engine emissions and increase traffic within the marine park. If small boats tie to trees to secure their position on the beach, the trees are at risk of breaking. Small boat moorings capable of accommodating dinghies and water taxis should, thus, be installed to reduce their impact within the TCMP.

It is recommended that new small boat moorings be installed around Horseshoe Reef, which will decrease the likelihood of dinghies anchoring on the coral reef. It will also increase the safety of snorkeling to have the dinghies secured near to the snorkelers as opposed to people's dinghies returning to the yacht after dropping people in the water. The TCMP rangers responsible for the installation of moorings have confirmed their knowledge of the locations of previous small boat moorings along Horseshoe Reef and have agreed that the new mooring systems can be installed at these locations.

Park management staff also identified the need for small boat moorings near beaches of Petit Bateau and Petit Rameau, and thus, it is recommended that twelve small boat moorings be installed (Figure 20).



Figure 18. Map showing current yacht moorings (black and white rings) and sites for small boat moorings near beaches of Petit Bateau and Petit Rameau (Google Earth, 2016).

5.6.3 Zones for Superyacht Mooring Systems in the TCMP

Currently, yachts that are too large for the moorings are meant to be anchoring within designated anchorage zones. These large yachts, commonly called ‘power boats’ or ‘super yachts’ can range from 65 feet to 300 feet in length. Recommended zones wherein a professional mooring systems company should assess sites for super yacht mooring systems are shown in Figure 21.

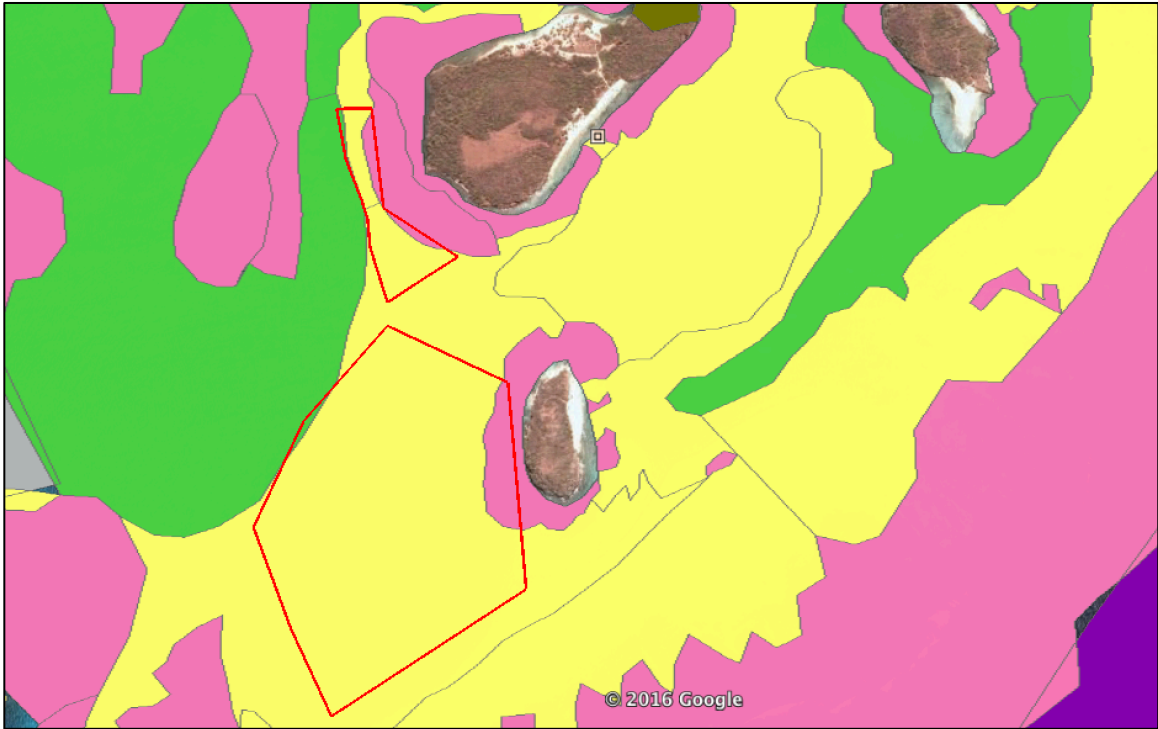

Figure 19. Suggested zones (red polygon) for superyacht mooring systems, west of Jamesby and southwest of Petit Bateau, TCMP. MarSIS habitat layers show areas dominated by sand in yellow, seagrass in green and coral in pink (Google Earth, 2016).

4.7.1 Yacht Moorings near Sandy Island, SIOBMPA

Thirteen potential new yacht mooring sites were identified south of Sandy Island (Figure 22). Twelve small boat moorings were sited, as depicted by the white squares. It is suggested that some small boat moorings be reserved for local use, while others be designated for dinghies.

The recommended sites include yacht mooring sites identified in 2010 that do not conflict with current mooring sites (i.e. at least 130 feet from any mooring system accommodating yachts up to 65 feet). The 2009 study found suitable rocks for drilling and installing epoxied eyebolt mooring systems, which could accommodate dingy and small boats (e.g. water taxis). Figure 11 displays the locations of the recommended and existing mooring systems near Sandy Island (See Appendix A for a summary of the recommended mooring locations).

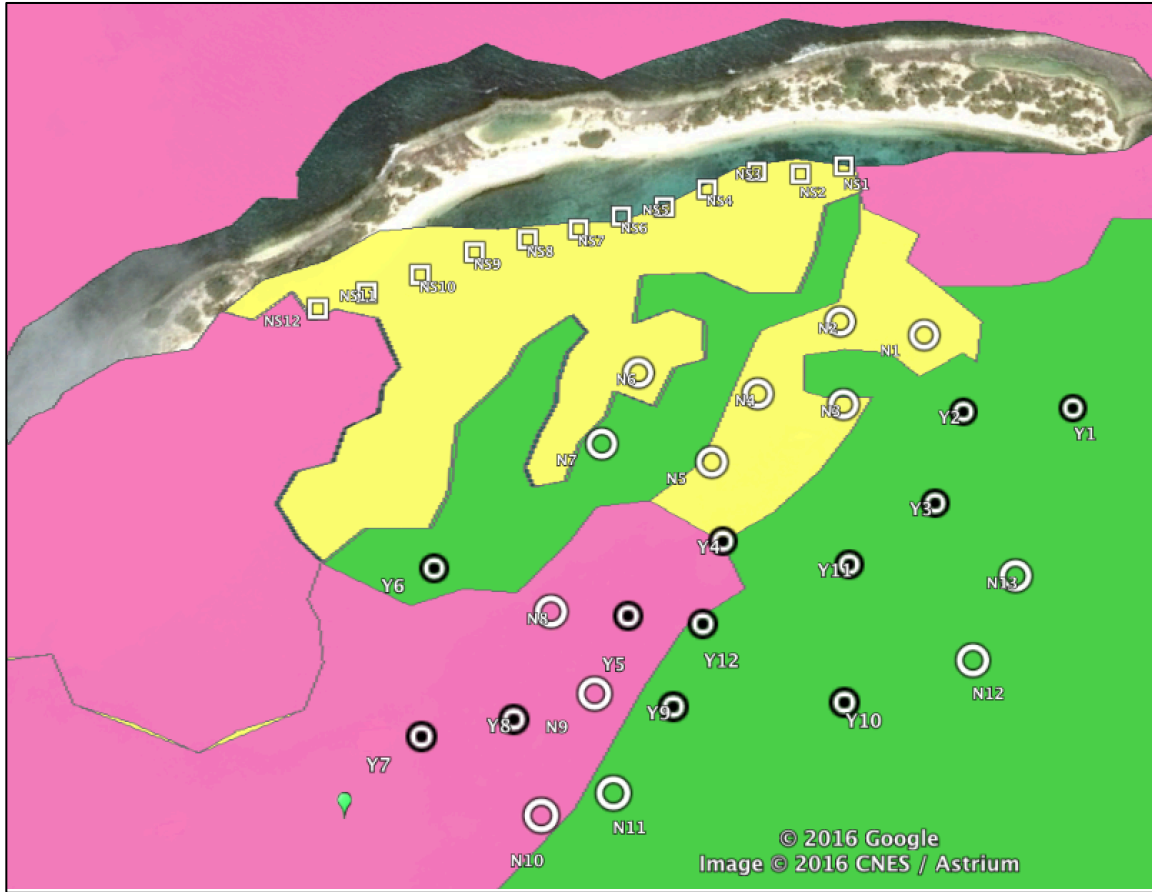

Figure 20. Map showing locations of current yacht moorings (black and white circles) and the potential sites for new moorings (white rings indicate yacht moorings; white square indicates small boat moorings) at Sandy Island, SIOBMPA, Grenada. MarSIS habitat layers show areas dominated by sand in yellow, seagrass in green and coral in pink (Google Earth, 2016).

5.6.4 Yacht Moorings near Paradise Beach, L’Esterre Bay, SIOBMPA

The seabed probe and site inspection conducted by Moor Seacure in 2009 determined that hydraulic embedment anchors were not suitable for use near Paradise Beach, L’Esterre Bay. There were also no suitable rocks for Epoxied pin systems. The in-water inspection of the current moorings near Paradise Beach found that manta and pin moorings have been utilized for overnight yacht moorings and a variety of ‘home-made’ anchors are securing the small boat moorings. This assessment recommends that a combination of concrete block type anchors and manta and pin type anchors be used for future yacht mooring installations near Paradise Beach so their success can be compared. It is suggested that additional small boat moorings be installed and properly maintained, as was recommended by interviewed dive shop operators who stated that this would increase access to Paradise Beach services (e.g. restaurants, shops). Additionally, small

boat moorings will decrease the threat of anchor damage close to shore, as well as reduce the incidence of boats tying to trees near the beach, which can cause breakage.

Seven potential sites for new yacht moorings and eleven small boat moorings have been identified in L’Esterre Bay off of Paradise Beach (Figure 23; (Appendix A for a summary of the recommended mooring locations). These locations are spaced with a minimum 130 feet between yacht moorings to accommodate vessels up to 65 feet in length. Prior to installation, an in-water inspection of these sites should identify an exact location where there is minimal seagrass coverage (i.e. the closest sand patch), and the exact depth of that location so the mooring system can be prepared with the appropriate length of downline (10 feet longer than depth at high tide; Fairhead and Baldwin, 2015).

5.6.5 Dive Moorings in SIOBMPA

The dive moorings within the SIOBMPA are monitored and maintained by the dive operators that use them (R. Laflamme, personal communication, July 6, 2016). The stakeholder workshop wherein the draft AMMP will be presented will include the three dive shops operating in the SIOBMPA. The dive shop representatives and MPA management staff will need to establish an arrangement regarding dive mooring management that is agreeable to all parties.

Dive mooring GPS coordinates were provided by Richard of Lumba Dive. Red dive flags indicate current moorings, while the orange dive flags indicate sites requiring dive moorings (Figure 23, 24). The current anchorage zone is the area within the green placemarkers shown in Figure 23. This sandy area is where boats anchor that exceed the size limit of the mooring systems.

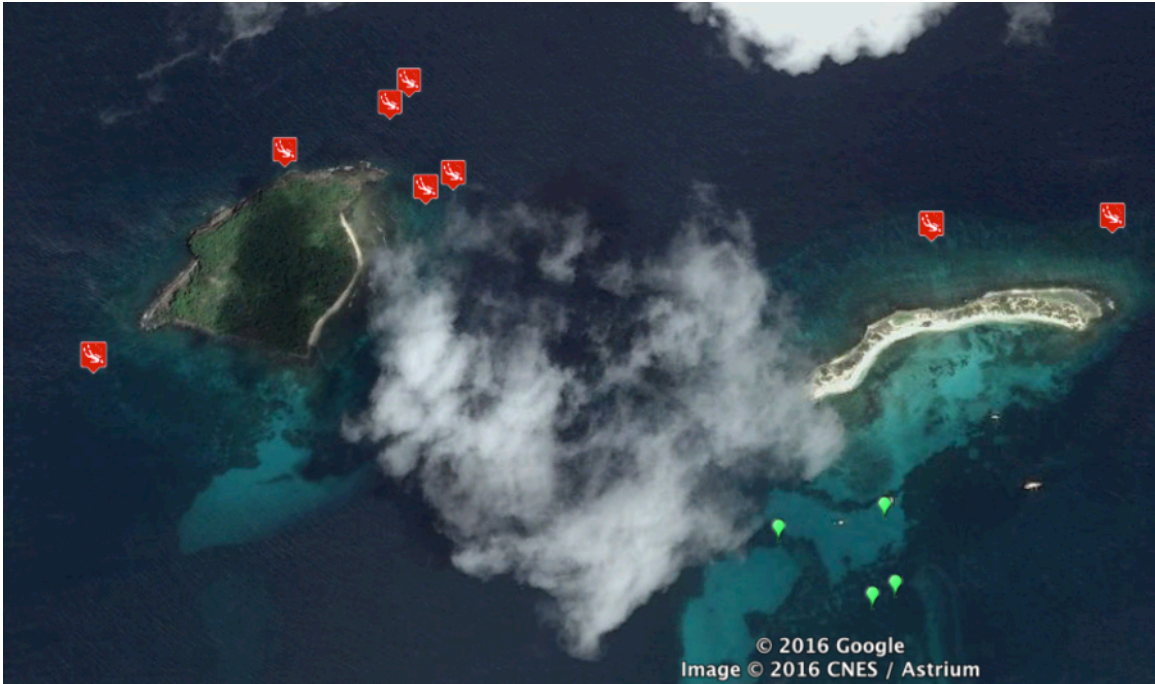

Figure 21. Map showing current dive mooring sites (red flags) near Mabouya (left) and Sandy Island (right), as well the anchorage zone south of Sandy Island, SIOBMPA, 2016.



Figure 22. Map showing current dive mooring sites (red flags) and dive sites requiring mooring systems (orange) near Sister Rocks (top left) and around Cistern Point, SIOBMPA (Google Earth, 2016).

5.6.6 SIOBMPA Boundary Demarcation Moorings

From Lumba Dive’s records of past mooring system locations, five key sites requiring mooring systems for boundary demarcation buoys were identified (Figure 25). These sites were identified based on the record’s notes that indicated SIOBMPA staff had requested the removal of other demarcation buoys and the upkeep of the moorings at these five sites. SIOBMPA has demarcation buoys, which can be redeployed once the mooring systems have been installed at the five sites.



Figure 23. Map of SIOBMPA with suggested boundary demarcation mooring sites (purple flags; Google Earth, 2016).

Chapter 6: Recommendations

6.1 Recommended Mooring Specifications

The Halas principle of mooring design should be used for new installations in the TCMP and SIOBMPA, as was recommended for the South Coast Marine Managed Area (Fairhead and Baldwin, 2015). A detailed description of the Halas mooring system design and directions for assembly is provided in Appendix C.1. Three-ton concrete anchor blocks are the recommended anchor type for yacht moorings in the TCMP since the manta and pin type anchors require specialized equipment for installation, and have proven less suitable to dynamic sandy bottom conditions (B. Wilson, personal communication, May 24, 2016). The existing manta and pin mooring systems within the SIOBMPA are performing well, however, most are only one year old. Since the SIOBMPA have the specialized equipment and skills necessary to install the manta and pin anchors, it is recommended that manta and pin anchors be used for the new yacht mooring systems near to Sandy Island. In their assessment of mooring site suitability, Moor Seacure recommended that embedment anchors (i.e. manta and pin) should not be used in L'Esterre Bay (Moir, 2007). Therefore, concrete block anchors should be utilized for the new moorings in L'Esterre Bay. Since the existing yacht moorings in L'Esterre Bay have manta and pin anchors, condition assessments should pay particular attention to the position of the anchor pins and could allow for a performance comparison between the two mooring anchor types.

In both MPAs, epoxy embedded pins can be used for small boat moorings where there are rocks suitable for secure the pin (Figure 26; Moir, 2009). Benefits of the Halas system are that it is user friendly, durable and easily maintained and repaired with locally available materials and resources. Mooring fabrication requires basic measuring and splicing skills.

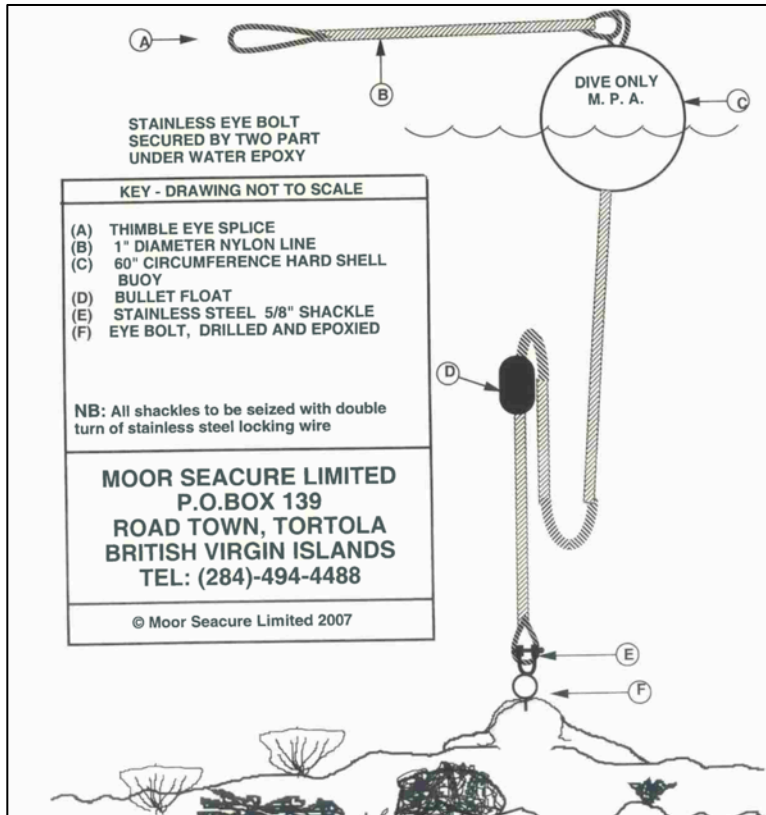

Figure 24. Epoxy embedded pin mooring system for small boats (Moir, 2009).

These larger boats can cause significant anchoring damage, and therefore, moorings should be provided instead of creating an additional anchoring zone or utilizing the existing anchoring zone. A mooring system appropriate for such large boats will be more costly, but the potential for mooring fees is also much greater for superyachts and small cruise ships. It is recommended that a professional mooring company, such as Moore Seacure International, be hired to install the mooring systems for superyachts and small cruise ships.

An inventory of mooring system components for yacht moorings and small boat moorings can be found in Appendix A. It is recommended that mooring buoys be colour-coded to communicate their intended use. Since the British Virgin Islands (BVI) is a popular yachting destination known for easy sailing conditions, many yachters visit the BVI prior to sailing in the Grenadines. It has therefore been suggested that the TCMP and SIOBMPA use the same colour-coding for mooring buoys that is used in the BVI (Appendix C.9).

6.2 Mooring Maintenance

6.2.1 Importance of Mooring Maintenance

Ensuring the mooring systems are properly maintained should be a principal priority of MPA management staff. Proper mooring maintenance promotes user safety, environmental protection and revenue generation (Diedrich et al., 2013). Poorly maintained mooring systems can lead to boater mistrust, which encourages anchoring and its associated threats. Poor mooring maintenance may also lead to breakages that can result in a yacht being set adrift, vulnerable to collisions with other yachts or groundings that can damage the boat and degrade benthic habitat (e.g. coral reef, sea grass beds). Furthermore, it is likely that visitors will be more accepting of increased fees if the mooring systems are well maintained and reliable.

6.2.2 Mooring Maintenance in the TCMP and SIOBMPA

The proposed mooring maintenance plans for MPAs draw from the ‘Standard Operating Procedures for Mooring Maintenance’ (SOPMM), which was prepared as an output of the Grenada Bank MPA Network Learning Exchange to Mustique (Harvey, 2013). The report was developed to assist the MPAs within the Grenada Marine Protected Area (GMPA) system with maintenance of their fixed mooring systems. All staff working on mooring maintenance should be familiar with the SOPMM.

The supervision of maintenance should be assigned to one individual. This person will be responsible for designating responsibilities and ensuring a mooring maintenance schedule is kept (see Appendix C.2 for a schedule form) and records are up-to-date. The schedule has been designed to be flexible so that the maintenance plan can adapt as local conditions and patterns of use change over time. The schedule has been added to the Grenada Bank MPA Network monitoring calendar in an effort to encourage all MPAs to perform mooring assessments and maintenance methodically.

As described in the SOPMM, mooring systems require maintenance to ensure that moorings are safe, reliable, and in an acceptable condition. The maintenance cycle and 15

standard operating procedures (SOPs) identified by Harvey (2013) can be found in Appendix C.8.

To facilitate the SOPs, this study recommends that a ‘Mooring Management Binder’ should be taken to the field daily to ensure all maintenance activities and mooring related incidents are recorded. The binder should contain mooring maintenance log sheets, a space for incident and public reports, and maps of the mooring fields (Appendix C.5). A mooring management pamphlet summarizing the SOPMM (Harvey, 2013) and the Moorings Plan for South Coast Marine Managed Area, SVG (Baldwin and Fairhead, 2015) was created as reference material (Appendix C.6).

6.3 Mooring Fees

6.3.1 Mooring Fee Collection Procedure

The collection of moorings fees occurs on a daily basis within the MPAs. It provides the opportunity for park rangers to greet and brief the visitors, collect the appropriate fees and ensure boats are properly secured to the appropriate mooring system. If boats need to anchor (e.g. if they are too large for the moorings), then the rangers should ensure the yacht anchors within the anchorage zone. It is recommended that this interaction between rangers and visitors be used to ensure that the boats are adhering to the holding tank regulations of the MPA. One of the rangers should board the boat and check that the holding tank is closed. Information on the boat and its stay should be recorded since it is an ideal opportunity to collect data that will be useful in terms of managing the mooring systems and in assessing the park’s carrying capacity. A checklist will be included in the Mooring Management Binder in order to ensure the rangers do not overlook any aspects of the recommended procedures (Appendix C.6)

6.4.2 Mooring Fee Costs

Well-managed mooring systems can be a successful sustainable financing mechanism, particularly in MPAs that are popular yachting destinations. An analysis of the spending

patterns of yachters in the Grenadines indicated that in 2012, only 2% of the expenditures were on government fees, which includes MPA visitation and mooring fees (Henry, 2013). Considering the marine ecosystem's beauty and productivity greatly contribute to the yachting tourism appeal of the region, it can be argued that a greater portion of the money being spent by yachters should contribute to marine conservation and management costs. Out of an analysis of the economic opportunities of the yachting industry, Henry (2013) identified five recommendations that would promote the economic success of the industry; one of the recommendations was to strengthen management of Marine Protected Areas. These findings should be considered when making decisions regarding the costs of the MPAs' mooring fees. This study's results indicate that the potential profits from mooring fees are not being maximized at either MPA.

Mooring fee records from SIOBMPA indicate that fees were not collected June-September in 2014 because the patrol boat was not operating at this time. In addition to a lack of enforcement, the absence of the patrol boat meant mooring fee profits were lost. It was suggested that better management of mooring fee profits could ensure that patrol boat costs do not deter its operation (anonymous personal communication, July 8, 2016). A comparison of the number of yachts recorded in the TCMP's visitation records with the mooring fee records indicated that only $\frac{1}{4}$ of the yachts paid mooring fees during the two years in which mooring records were kept. These results highlight the need to enforce no-anchoring regulations and suggest that the current anchoring practices are likely having negative impacts on the health of benthic ecosystem components. In SIOBMPA, boats pay mooring fees even if they need to anchor within the designated anchorage zone. This practice should be adopted in the TCMP in order to ensure that boaters are not anchoring to avoid mooring fees. Based on this study's results, introducing an anchoring fee equal to the mooring fee would quadruple revenue from yachts (not counting entrance fees per person), adding 270,000 XCD/year to park revenue (6,000 yachts/year x 45 XCD/yacht). This is assuming that the mooring or anchoring fees would not reduce visitation. Given that a typical yacht charter in the Grenadines costs US\$4,000 to \$13,000 for a seven day

trip, and that the TCMP is one of the premier attractions, it seems unlikely that a mooring or anchorage fee would deter tourists from visiting the MPA.

It was suggested that a higher mooring fee could be implemented without issue as long as the moorings were high quality and well maintained (anonymous personal communication, June 14, 2016). If the fees were to increase, the amount of overnighting yachts in the MPA might decrease, but the same amount of money could be generated as long as the decrease in users was not significantly reduced. For instance, in order to make \$1,000 EC on mooring fees in one night, the park could accommodate 22 yachts paying 45 EC or 13 yachts paying 75 EC. There would need to be 9 yachts unwilling to pay the higher fee in order for less money to be generated.

Some stakeholders may be concerned that increasing mooring fees would negatively impact visitation rates and decrease the amount of tourism dollars being spent in the region. Although this concern is valid, experience from the Mustique Marine Conservation Area (MMCA) suggests that increased mooring fees will not deter tourism; MPA managers working at Mustique reported that visitation has not decreased since the new mooring fees were set at 185 USD for three nights (B. Little, personal communication, June 8, 2016). It is important to note that the MMCA surrounds the privately owned island of Mustique, SVG, and receives high-end tourism.

If moorings for large boats (i.e. super yachts or small cruise ships) are installed within the TCMP and SIOBMPA, as recommended by this study, the cost of overnighting on the mooring will need to be established. It is suggested that consideration be given to the average number of people aboard these large boats and the high costs of chartering superyachts. The marina development at Glossy Bay is anticipated to increase the amount of high-end superyachts in the region, which suggests there will be an increased profit potential for superyacht moorings, particularly at the TCMP due to its popularity and relatively close proximity.

At the very least, the set price should ensure the mooring fee profits are enough to fund the mooring systems' maintenance costs and the fee-collection patrols. Stakeholder input on appropriate costs will be gathered at the multi-stakeholder meetings that this study has recommended. Ultimately, the mooring fee costs agreed upon by the TCMP and SIOBMPA management boards will need government approval in order to be adopted.

6.4 Sewage Waste Management Options

6.4.1 Sewage at Sea

Any boat with bathroom facilities on board requires a waste management system. Black water refers to toilet waste, while grey water is the term for wastewater from sinks and showers. Typically, grey water is flushed overboard without treatment. Many countries have adopted regulations that prohibit the direct discharge of black water into coastal or freshwater areas because of the threats of nutrient pollution, harmful pathogens, and reduced aesthetic appeal. The need to manage black water on board yachts can be addressed in a variety of ways, including the use of marine sanitation devices (MSDs), or recirculating, composting and incinerating toilets.

MSDs are systems that treat black water to reduce the amount of bacteria entering the sea upon waste disposal. Type 1 MSD involves the processing of sewage using chlorination or maceration. Type 2 relies on the bacteria present within the sewage to facilitate aerobic digestion. Type 3 refers to the storage of waste in containers, known as holding tanks, and the subsequent disposal of the collected waste.

Cruise ships commonly use MSDs, but their effectiveness varies and depends on the type of MSD used. A study conducted by the Alaska Department of Environmental Conservation found that 55% of black water treated by MSDs, mainly Type 2, on cruise ships contained fecal coliform above the federal standard of 200 fecal coliform per 100 milliliter (EDEC, 2000). As such, the TCMP and SIOBMPA should adopt a regulation to prohibit the release of MSD treated black water within the MPAs' boundaries.

Almost all new yachts are built with holding tanks (T. Second, personal communication, July 18, 2016). Also termed ‘black water tanks’, holding tanks are storage containers that connect to toilets on yachts and other vehicles (Figure 16-18).

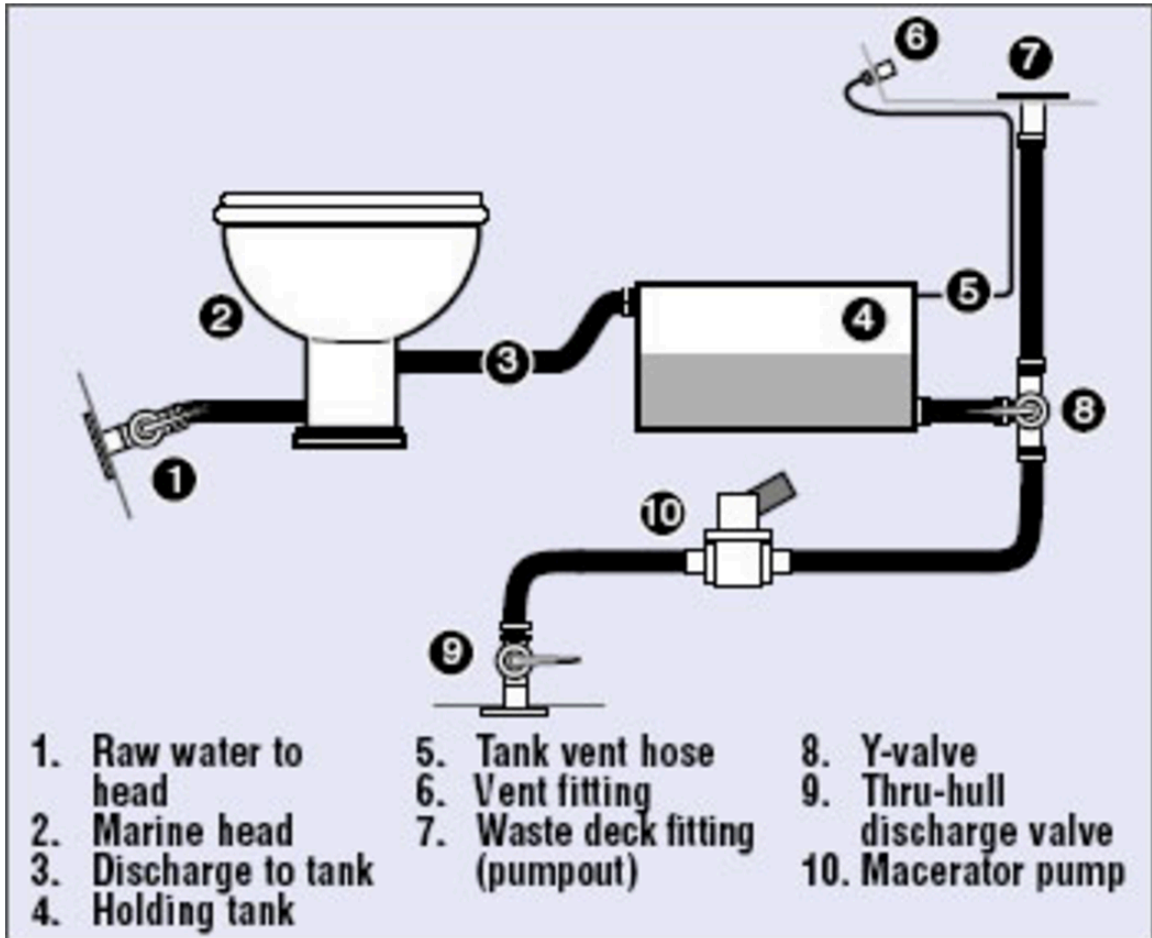

Figure 16. Diagram showing a holding tank system with multiple discharge options (Burden, 2016).

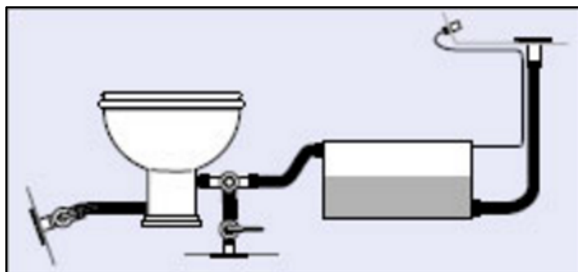

Figure 17. Holding tank with optional overboard discharge (Burden, 2016).

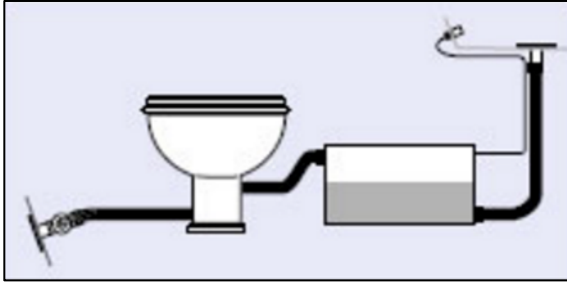

Figure 18. Holding tank without self discharge option (Burden, 2016).

Some designs are built with an optional overboard discharge mechanism (see Figure 16-17), while others do not give the boater the option to discharge the sewage directly into the sea (Figure 18). It has been reported that many of the charter yachts operating within the MPAs position the Y valve to facilitate the direct disposal of black water into the sea (anonymous personal communication, July 2016). This practice is done to avoid the risk of the Y valve seizing shut, which apparently occurs frequently in older holding tank systems and causes unpleasant issues that can detract from the guests' experience (anonymous personal communication, July 2016).

6.4.2 National and International Regulations on Sewage Disposal at Sea

The International Convention for the Prevention of Pollution from Ships (MARPOL) provides a global set of protocols relating to ship pollution, including regulations regarding the discharge of sewage from ships (Annex IV). The regulations address the ships' equipment and systems for the control of sewage discharge, the provision of port reception facilities for sewage, and requirements for survey and certification. Annex IV, which was revised in 2004 and adopted in 2005, apply to ships certified to carry 15 or more passengers, or that exceed 400 gross tonnages. Regulations prohibit the discharge of sewage into the sea within a specified distance from the nearest land. Ships may discharge comminuted and disinfected sewage at a distance of more than three nautical miles, while sewage that is not comminuted or disinfected may be discharged at a distance of more than 12 nautical miles from the nearest land. Governments committed to MARPOL are required to ensure the provision of adequate reception facilities at ports and terminals for the reception of sewage.

SVG's National Maritime Administration is working towards adopting MARPOL protocol. The administration is in the process of drafting a shipping and marine pollution bill that will provide a legal framework to regulate holding tank practices within SVG's territorial waters (D. Robin, personal communication, May 16, 2016). This bill will give effect to some MARPOL regulations, but it is unknown whether the bill will contain regulations for pleasure crafts that carry less than 15 passengers. There is no international convention that requires pleasure crafts to be fit with holding tanks or regulates holding tank disposal practices, so SVGs' Maritime Administration must determine a set of regulations that is appropriate for their territorial waters. Although the Tobago Cays Marine Park has the authority to adopt regulations specific to the park, national legislation is required to provide supporting legal framework that will allow for fines to be issued if regulations are broken. Similarly, Grenada subscribes to MARPOL, however, supporting national legislation is lacking (Jeco Caribbean, 2011).

Ideally, all boats entering an MPA should be required to have functioning holding tanks to ensure no black water is flushed into the marine environment. Many countries now have national legislation that prohibits the discharge of untreated sewage anywhere within 12 nautical miles of land (i.e. their territorial waters). Countries such as Finland, Greece, Turkey and the Netherlands have adopted this regulation, making holding tanks or on-board marine sanitation devices (MSDs) mandatory. Other countries have this regulation, but have defined characteristics of boats that qualify their exception from the regulation. For instance, Denmark allows boats built prior to January 1980 to discharge sewage when two nautical miles from the shore; boats built between 1980 and January 2000 that are either less than 10.5m LOA or have a maximum beam of less than 2.8m do not require a holding tank and can discharge sewage when two nautical miles from the shore; and boats built after January 2000 must have a holding tank that can be emptied via a deck fitting.

6.4.3 Regulating Holding Tanks in the TCMP and SIOBMPA

Regulations that encourage the proper use of holding tanks within the MPAs are required. Yachts without holding tanks or that empty their contents within the MPA pose threats,

including nutrient pollution, the release of harmful bacteria and a decrease in tourism appeal.

There may be resistance to adopting regulations that prohibits all boats without functioning holding tanks from overnighting in the TCMP because it could be perceived as a deterrent to visitation. Given the importance of tourism to the region's economy, the fear that stricter regulations will decrease tourism is understandable. It is vital, however, to consider the risk visitation poses to the tourism industry if visitors cause detrimental impacts that decrease the tourism appeal of the MPA. It is the author's opinion that if conservation of the marine ecosystems within the TCMP and SIOBMPA is held as the top priority, the park will be capable of sustaining tourism over the long-term. Regulations that help to ensure the MPA remains rich in life and encourages stakeholders to view the park (e.g. mooring systems) as well managed, will increase the tourism appeal and thus, revenue potential of the MPA.

To ensure that regulations are supported, implemented and enforced, awareness of the intent and importance of the regulations must be promoted, and the feasibility of the regulations must be considered. It is therefore recommended that the initial regulations relating to sewage-pollution do not completely ban boats without functioning holding tanks from the park, but rather encourage boat owners to consider upgrading their sewage facilities. As an incentive, boats that do have functioning holding tanks should receive a discounted mooring fee. This will incentivise charter yacht companies and pleasure craft owners to install or upgrade holding tanks. If water quality monitoring indicates that sewage waste pollution is occurring at a level that could compromise the health of the marine ecosystems or recreational users, the regulation can be modified to restrict access to boats without functioning holding tank facilities.

Furthermore, it is recommended that boats without functioning holding tanks should overnight at specific moorings. A flow study would be required in order to identify which mooring locations would be the most appropriate to designate for boats without holding tanks. Sites should be selected if the water flow indicates that disposed sewage would be

dispersed via currents into deeper waters away from the shallow coral reef and seagrass ecosystems.

Fluorescent dye tablets can also be used to discourage improper waste disposal by placing tablets in vessel holding tanks so the water will be coloured if the holding tank is emptied. The colour degrades via solar radiation in a matter of days. Marinas use this technique to ensure vessels are not releasing sewage waste within the harbour (Geosyntec, 2016). Tablets could be placed in holding tanks when mooring fees are collected. It is recommended that two tablets be used per holding tank (Ben Meadows, 2016). The cost of dye tablets will limit the frequency at which this method could be applied, as the cost of 200 tablets is around 45.00 USD (Ben Meadows, 2016). Given the expense, it is recommended that the tablets be used on vessels that have large holding tanks because they pose a greater threat than holding tanks that contain small volumes of waste.

6.4.4 Sewage Waste Collection

One of the two most important factors in preventing sewage pollution from vessels is to ensure that sewage pump-out facilities are adequate and reasonably available (Geosyntec, 2016). The other significant aspect of preventing improper sewage disposal at sea is boater education, specifically promoting awareness about no-discharge zones and the rationale behind their designation (Geosyntec, 2016).

In order to encourage the proper use of holding tanks, there must be sewage pump-out facilities available near to the MPA. It must be convenient for boaters to have their holding tanks emptied in order to incite boaters to choose to use a pump-out facility instead of disposing the waste into the sea. The creation of a pump-out facility could be an alternative livelihood project associated with MPAs. Funding support would be needed to purchase the equipment and provide training, but pump-out fees would be collected to generate income over the long-term.

Since Union Island is the closest tourist port to the TCMP and is often visited prior to the TCMP, it is recommended that holding tank pump-out facilities be developed. Such a project would also benefit the Clifton Harbour, which is an area threatened by nutrient pollution from yachts that overnight and improperly dispose of waste (Homer and Collins, 2008). The Strategic Action Plan for Clifton Harbour, highlights strategies of SVG's National Environmental Strategy Action Plan (NEMS) that are relevant to Clifton Harbour and, more broadly, Union Island and the surrounding region (Homer and Shim, 2004). The initiation of sewage pump-out facilities for yachts would align with Strategy 31 of the NEMS: Adopt and implement appropriate measures to adequately manage solid and liquid waste, including hazardous waste, and atmospheric pollutants. Furthermore, the development of sewage pump-out facilities would address the call to ensure that untreated effluent is not disposed into the marine environment, a need highlighted in the tourism sector policy 'The National Physical Development Plan (2002-2022).

A pump-out facility to service the yachts visiting the SIOBMPA should be located in one of the bordering communities of Carriacou, Grenada. It is unknown whether the Tyrell Bay Marina will have sewage pump-out facilities, or when the marina will be operational as deadlines continue to be pushed back (anonymous personal communication, July 2016). If pump-out facilities are not going to be available at the marina, there could be an opportunity for a sustainable livelihood project to support the creation of a pump-out facility for the MPA's visitors.

6.4.5 Sewage Waste Treatment

It is crucial to consider what will happen to the waste once it is collected. The treatment and strategic disposal of the collected sewage is required in order for the effort of collecting the sewage to be worthwhile. If the collected sewage is pumped untreated into the coastal zone, it will likely cause more adverse impacts than if it had been disposed of while the vessel was at sea where dispersion is more significant. Since there are no municipal sewage treatment facilities on Union Island or Carriacou, it is recommended that the potential of anaerobic digestion waste treatment facilities be further explored.

6.5 Education and Awareness

6.5.1 Promoting Mooring Systems

Various strategies have been implemented to reduce the impacts of anchors on seagrass and coral reef ecosystems including anchoring bans, limitations on the size and number of boats, and the provision of boat moorings (Milazzo et al., 2003). In order for mooring systems to be an effective management measure, moorings must be available and boat operators must be willing to use the mooring buoy and pay the associated fees. Given the limited legal capacity and resources of many MPAs, however, enforcing anchoring bans and providing well-maintained moorings can be challenging. In such situations, the self-regulatory approach based on educating and informing boaters on anchoring threats may be more effective in terms of mitigating anchor damage (Antonini and Sidman, 1994). For instance, Diedrich et al., (2013) investigated how the attitudes and beliefs of boat operators influences their willingness to use mooring buoys as opposed to anchors. The study showed a positive relationship between attitudes associated with perceptions of safety, space, and minimizing impacts on sensitive habitat, and boaters' willingness to use buoys and pay mooring fees. Awareness regarding the need to minimize negative impacts on sensitive habitat, in this case seagrass (*Posidonia oceanica*), positively influenced boaters' perceptions regarding mooring buoys, while crowding in the study site had a very minor influence. Antonini and Sidman (1994) found a similar positive relationship between boater perception and the use of moorings. A field-tested guidebook with large-scale maps (illustrating sensitive habitats and shore features and services) was found to influence more than 50% of boaters' decisions on where to anchor, indicating the potential of informed voluntary decisions to reduce anchoring threats (Antonini and Sidman, 1994).

Adopting the self-regulatory approach necessitates the development and distribution of site-specific educational materials. In the cases of the TCMP and SIOBMPA, informative materials are needed to ensure that sailors are aware of the opportunities to use the moorings, the best-practices for mooring use, the mooring fees and payment methods, and the MPA regulations (e.g. no-anchoring unless in anchoring zone, no waste/holding tank disposal). There are already brochures for both MPAs, which could be updated to

include the aforementioned topics, and printed and distributed. The information could also be featured in Doyle's Sailing Guide, a publication that is standard on the majority of charter yachts utilizing the area. Charter yacht companies could ensure each yacht has a laminated version and could review it during their safety briefs. Having laminated copies would cut down on printing resources. Tourism bureaus, customs offices, dive shops and hotels could have copies of the brochure available. Publications targeted at sailors, such as Caribbean Compass should also provide this information. This information, as well as maps with the mooring fields, anchoring zones and park boundaries, should also be available on the MPAs' website. Additionally, it is recommended that navigational companies be approached to include MPA regulations, updated anchoring zone and mooring field locations and information on waste pump-out facilities. It has been emphasized that there is a need to have all educational information available in multiple languages, notably English and French.

To encourage the use of the moorings, there must also be evidence regarding the moorings' maintenance available for interested visitors. It is recommended that the Mooring Management Binder be taken on all fee-collection patrols so that the mooring maintenance records and incident reports can be used to promote a positive perception of the moorings.

6.5.2 Awareness-raising to Mitigate Yachting Impacts

In addition to providing the aforementioned information to promote the use of moorings, the suggested site-specific educational materials should contain information about waste disposal regulations and available pump-out facilities. Making this information prevalent will not only promote regulatory compliance, but it is likely to improve the tourism appeal of the MPAs.

Sailors that travel on their own boat, commonly called 'yachties', are a stakeholder group that will require attention when promoting awareness regarding waste disposal. Outreach may be more challenging relative to park visitors sailing in charter yachts because there is not the opportunity of briefing visitors prior to the beginning of their trip. If navigational applications agree to provide information on MPAs, information on waste disposal

protocol and pump-out facility locations could also be included. The information should also be available online and at the Customs Office so people entering the country can be informed prior to visiting the MPA.

The charter yacht industry could be a key force in shifting the yachting sector towards more eco-friendly operations. It is recommended that a fact-sheet on eco-friendly yacht practices and products should be electronically distributed to the charter yacht companies operating in the Grenadines and posted online. For instance, it can be recommended that vinegar replace the potentially toxic chemicals that are often used to clean holding tanks. Additionally, there is a microbe-based antifouling agent that is more eco-friendly and cheaper than conventional antifouling agents because it lacks heavy metals (S. Carey, personal communication, July 24, 2016).

6.6 Carrying Capacity

The determination and subsequent enforcement of a yachting carrying capacity for each MPA could help to achieve a healthy balance between tourism use and conservation. This study was not able to determine the carrying capacity of yachting tourism within these MPAs due to a lack of data. Neither MPA has had the means to support research to monitor the ecological impacts of yachts, nor to gauge the tourism appeal and perceived safety.

There was, however, a study conducted in 2003, that highlighted overcrowding of boats was one of the most commonly reported problems within the TCMP, which can have more than 100 yachts within the park during high season (MEDO, 2003). If no-anchoring regulations are enforced as this management plan strongly recommends, the issue of overcrowding should be addressed because the mooring systems are spaced to provide swing room and privacy. Future assessments of MPA carrying capacities considering the pressure of overcrowding could attain qualitative information on the state of tourism appeal and perceived safety of each MPA from charter yacht companies, as they gather feedback from their clientele.

The AMMPs informed by this research prescribe WQM be conducted to ensure the level of pollution is adequately controlled by the proposed waste mitigation methods. If water quality data indicates that waste pollution from yachts is having deleterious impacts, access to moorings could be restricted to lessen the ecological pressure, or alternative waste management options could be pursued.

The AMMPs specify that records of moorings should include the mooring buoy identification number and whether or not the yacht has a functioning holding tank. Future analysis of these records will reveal usage patterns that could provide insight into the level of the pressures placed on specific areas within the MPAs. Subsequently, this knowledge could be used to inform access restrictions and limit the number of yachts overnighting in the areas where WQM indicates pollution is significant.

Chapter 7: Conclusion

This research has determined that a more extensive, well-managed and maintained mooring system could contribute to the TCMP and SIOBMPA as follows:

- Decrease the threats of anchoring to seagrass and coral reef ecosystems
- Ensure that the spacing between vessels is adequate to prevent collisions and overcrowding
- Generate profits from mooring fees that can be used to cover maintenance costs and patrol boat expenses, as well as to support conservation activities
- Provide an opportunity for data collection of yacht characteristics and use patterns
- Promote awareness amongst visitors via briefings during mooring fee collection

In order to maximize on the benefits of mooring systems and mitigate the threats of yachts beyond anchoring, the study put forth a number of management recommendations for the two MPAs of focus. It was recommended that the costs of mooring fees be increased; that sewage-waste mitigation measures be adopted; that sewage collection and treatment options be further explored; and that educational material be developed and distributed. It was determined that as management strategies are applied and evaluated, monitoring data is collected and interpreted, and policies or regulations are implemented, aspects of the management approach will need to be adapted. Water quality monitoring has been recommended as a method of monitoring the severity of improper waste disposal from yachts, and in combination with visitation and yacht characteristic data, is intended to enhance the understanding of the MPAs' yachting carrying capacity. This will be crucial in achieving a level of tourism that does not compromise the MPAs' ecosystem health or reduce the tourism appeal.

Although the approaches have been tailored to the context of each MPA, the strategies that prove effective could be adopted throughout the Grenadines Network of MPAs. The implementation of this study's recommendations would provide data that could lead to a

better understanding of the yachting sector's impacts at a regional scale. In addition, the proposed outreach and stakeholder engagement strategies could lead to an increased awareness of the threats of yachts and associated mitigation methods, which could promote more sustainable yachting practices across the Grenada Bank. Furthermore, this research has highlighted the need for enforceable regulations within MPAs, particularly with regards to anchoring bans and waste disposal, which could influence national-scale policies. Ultimately, this study highlights the opportunities for adaptive management to address the challenges of MPAs wherein the pressures of economic drivers are compromising the success of conservation objectives.

References

- Antonini, G., Zabler, L., Sheftall, W., Stevely, J., & Sidman, C. (1994). *Feasibility of a non-regulatory approach to bay water storage management for sustainable recreational use.*
- Ashton, P. G., & Chubb, M. (1972). *a preliminary study for evaluating the capacity of waters for recreational boating*. *JAWRA Journal of the American Water Resources Association*, 8(3), 571-577. doi:10.1111/j.1752-1688.1972.tb05179.x
- Atkins, J. P., Burdon, D., Elliott, M., & Gregory, A. J. (2011). *Management of the marine environment: Integrating ecosystem services and societal benefits with the DPSIR framework in a systems approach.* *Marine Pollution Bulletin*, 62(2), 215-226.
- Backhurst, M., & Cole, R. (2000). *Biological impacts of boating at kawau island, north-eastern new zealand.* *Journal of Environmental Management*, 60(3), 239-251.
- Baldwin, K., D. Gill, A. Cooke, T. Staskiewicz, D. Lizama, R. Mahon, P. McConney and H.A. Oxenford. 2006. *A socio-economic and space-use profile of Grenadine marine resource users.* Centre for Resource Management and Environmental Studies (CERMES) technical report. University of the West Indies, Cave Hill Campus, Barbados. 116 pp.
- Ban, N. C., Adams, V. M., Almany, G. R., Ban, S., Cinner, J. E., Mccook, L. J., . . . White, A. (2011). *Designing, implementing and managing marine protected areas: Emerging trends and opportunities for coral reef nations.* *Journal of Experimental Marine Biology and Ecology*, 408(1), 21-31. doi:10.1016/j.jembe.2011.07.023
- Ban, N. C., Cinner, J. E., Adams, V. M., Mills, M., Almany, G. R., Ban, S. S., . . . White, A. (2012). *Recasting shortfalls of marine protected areas as opportunities through adaptive management.* *Aquatic Conservation: Marine and Freshwater Ecosystems*, 22(2), 262-271. doi:10.1002/aqc.2224
- Bell, C., Needham, M., & Szuster, B. (2011). *Congruence among encounters, norms, crowding, and management in a marine protected area.* *Environmental Management*, 48(3), 499-513. doi:10.1007/s00267-011-9709-1
- Ben Meadows. (2016). *BRIGHT DYES Biodegradable Dye Tracers.* Retrieved from http://www.benmeadows.com/bright-dyes-biodegradable-dye-tracers_36816829/
- Borja, Á., Elliott, M., Carstensen, J., Heiskanen, A., & van de Bund, W. (2010). *Marine management—Towards an integrated implementation of the european marine strategy framework and the water framework directives.* *Marine Pollution Bulletin*, 12(60), 2175-2186.
- Breda, A., & Gjerde, K. (1996). *Types of Mooring Buoy Systems.* PADI Mooring Buoy Guide. PADI Project Aware, USA. 92 pp.

Burden, T. (2016). *Selecting a Sanitation System*. Retrieved from <http://www.westmarine.com/WestAdvisor/Selecting-a-Sanitation-System>

Caribbean Conservation Association. (CCA;1991a). *Grenada: Country environmental profile*. Grenada: Country environmental profile.

Caribbean Conservation Association. (CCA;1991b). *St. Vincent and the Grenadines: Country environmental profile*. St. Vincent and the Grenadines: Country environmental profile.

Caribbean Environmental Health Institute (CEHI; 2004). *A Directory of Environmentally Sound Technologies for the Integrated Management of Solid, Liquid, and Hazardous Waste or SIDS in the Caribbean Region*. Retrieved from <http://bit.ly/2egAx5E>

Carilli, J. E., Norris, R. D., Black, B. A., Walsh, S. M., & McField, M. (2009). *Local stressors reduce coral resilience to bleaching*. *Plos One*, 4(7), e6324.

Creed, J. C., & Amado Filho, G.,M. (1999). *Disturbance and recovery of the macroflora of a seagrass (Halodule wrightii Ascherson) meadow in the Abrolhos Marine National Park, Brazil: An experimental evaluation of anchor damage*. *Journal of Experimental Marine Biology and Ecology*, 235(2), 285-306. doi:10.1016/S0022-0981(98)00188-9

Davenport, J., and Davenport, J. L. 2006. *The impact of tourism and personal leisure transport on coastal environments: A review*. *Estuarine, Coastal and Shelf Science*, 67(1), 280-292.

Diedrich, A., Balaguer Huguet, P., & Tintoré Subirana, J. (2011). *Methodology for applying the limits of acceptable change process to the management of recreational boating in the Balearic Islands, Spain (Western Mediterranean)*. *Ocean and Coastal Management*, 54(4), 341-351. doi:10.1016/j.ocecoaman.2010.12.009

Diedrich, A., Terrados, J., Arroyo, N. L., & Balaguer, P. (2013). *Modeling the influence of attitudes and beliefs on recreational boaters' use of buoys in the Balearic Islands*. *Ocean & Coastal Management; Modeling the Influence of Attitudes and Beliefs on Recreational Boaters' use of Buoys in the Balearic Islands*, 78, 112-120.

Dinsdale, E. A., & Harriott, V. J. (2004). *Assessing anchor damage on coral reefs: A case study in selection of environmental indicators*. *Environmental Management*, 33(1), 126-139.

Evans, M. C., Possingham, H. P., & Wilson, K. A. (2011). *What to do in the face of multiple threats? Incorporating dependencies within a return on investment framework for conservation*. *Diversity and Distributions*, 17(3), 437-450.

Fairhead, B. & Baldwin, K. (2015). *Moorings plan for the South Coast Marine Park, St. Vincent. Prepared for the CATS 2 Project. 1-35.*

Fava, F., Ponti, M., Scinto, A., Calcinai, B., & Cerrano, C. (2009). *Possible effects of human impacts on epibenthic communities and coral rubble features in the marine park of bunaken (indonesia). Estuarine, Coastal and Shelf Science, 85(1), 151-156.*

Flynn, R. L. (2015). *Boat anchoring contributes to coral reef degradation in the british virgin islands.*

García-Charton, J. A., Bayle-Sempere, J. T., Sánchez-Lizaso, J. L., Chiesa, P., Llaurodo, F., Pérez, C., & Djian, H. (1993). *Respuesta de la pradera de posidonia oceanica y su ictiofauna asociada al anclaje de embarcaciones en el parque nacional de port-cros (francia).*

Gelcich, S. (2013). *Financing marine protected areas through visitor fees: Insights from tourists willingness to pay in chile. Ambio, 42(8), 975-984. doi:10.1007/s13280-013-0453-z*

Geosyntec. (2016). *Massachusetts Nonpoint Source Pollution Management. Sewage Pumpout Facilities Fact Sheet. Retrieved from <http://bit.ly/2egzpz1>*

Glynn, P. W. (1994). *State of coral reefs in the galápagos islands: Natural vs anthropogenic impacts. Marine Pollution Bulletin, 29(1), 131-140.*

Group on Environmental Performance. (GEP; 1993). *OECD core set of indicators for environmental performance reviews Organisation for Economic Co-operation and Development.*

Harvey, O. 2013. *Standard Operating Procedures for Mooring Maintenance.*

Harvey, O., & Baldeo, R. 2013. *Stakeholder Led Co-management Governance Regimes: The New Paradigm for Marine Protected Areas in Grenada, West Indies. Grenada Fisheries Department, Melville Street, St. George 's, Grenada.*

Hawker, D., & Connell, D. (1989). *An evaluation of the tolerance of corals to nutrients and related water quality characteristics. International Journal of Environmental Studies, 34(3), 179-188. doi:10.1080/00207238908710526*

Heeney, E. (2015). *Connection and understanding: The basis of a positive mutual gaze between residents of a small island developing state and a community of multinational ocean cruisers. World Leisure Journal, 57(2), 118-130. doi:10.1080/16078055.2015.1034342*

Hemminga, M. A., & Duarte, C. M. (2000). *Seagrass ecology Cambridge University Press.*

Henry, A., V. (2013). *The Marine and Yachting Sector in Grenada Economic Impact Assessment Final Report. Ideas to Business Limited, Trinidad and Tobago. Grant No. GA 38/GRN*

Hoggarth, D. (2007). *Tobago Cays Marine Park 2007-2009 Management Plan. Prepared for: Organization of Eastern Caribbean States (OECS) Environment and Sustainable Development Unit (ESDU), St. Lucia. 100 p.p*

Homer, F. and D. Shim. 2004. *St. Vincent and the Grenadines Environmental Management Strategy and Action Plan, 2004-2006. April 16th 2004. 50 pp.*

Jenkins, J., C. (1999). *The Humanure Handbook: A guide to composting human manure. Chelsea Green Publishing, Grove City, PA 16127.*

Joachim and Associates Ltd. (2008). *Socioeconomic Value and Cost Benefit Analysis of Alternative Livelihoods Sub-Projects in the Tobago Cays Marine Park. TCMP Contract No: 09 2008*

Lewis, A. R. (1998). *Effects of experimental coral disturbance on the population dynamics of fishes on large patch reefs. Journal of Experimental Marine Biology and Ecology, 230(1), 91-110.*

Laflamme, R. (2010). *Installation of a Mooring and Demarcation Buoy System for the SIOBMPA. Presented to The Nature Conservancy and the National Fish and Wildlife Foundation. Project number FY10-C-NFWF-VI-LUMBADIVE.*

Lloret, J., Zaragoza, N., Caballero, D., & Riera, V. (2008). *Impacts of recreational boating on the marine environment of cap de creus (mediterranean sea). Ocean and Coastal Management, 51(11), 749-754. doi:10.1016/j.ocecoaman.2008.07.001*

Mangi, S. C., Roberts, C. M., & Rodwell, L. D. (2007). *Reef fisheries management in kenya: Preliminary approach using the driver–pressure–state–impacts–response (DPSIR) scheme of indicators. Ocean & Coastal Management, 50(5), 463-480.*

Marszalek, D., S., (1981). *Effects of sewage effluents on reel corals. 4th International Coral Reef Symposium Manila. Vol. 2, 15-20.*

Mayreau Environmental Development Organization (MEDO; 2003). *A Management Proposal for the Tobago Cays Marine Park, St. Vincent and the Grenadines.*

MDDNR. 1991. *A Guidebook for Marina Owners and Operators on the Installation and Operation of Sewage Pumpout Stations. Maryland Department of Natural Resources, Boating Administration, Annapolis, MD.*

Milazzo, M., Badalamenti, F., Ceccherelli, G., & Chemello, R. (2004). Boat anchoring on *Posidonia oceanica* beds in a marine protected area (Italy, western Mediterranean): Effect of anchor types in different anchoring stages. *Journal of Experimental Marine Biology and Ecology*, 299(1), 51-62.

Ministry of Carriacou and Petite Martinique Affairs. (MCMPPA; 2015). Sandy Island/Oyster Bed Marine Protected Area Management Plan 2015-2025.

Moir, D., J. (2007). Mooring Feasibility Report Sandy Island Oyster Bay Marine Protected Area, Carriacou, Grenada. Provided by Moor Seacure International Ltd. Commissioned by The Nature Conservancy. Contract number EC-041707007.

Montefalcone, M., Chiantore, M., Lanzone, A., Morri, C., Albertelli, G., & Bianchi, C. N. (2008). BACI design reveals the decline of the seagrass *Posidonia oceanica* induced by anchoring. *Marine Pollution Bulletin*, 56(9), 1637-1645.

Murdoch, W., Polasky, S., Wilson, K. A., Possingham, H. P., Kareiva, P., & Shaw, R. (2007). Maximizing return on investment in conservation. *Biological Conservation*, 139(3), 375-388.

Nichols, J. (2012). Evidence, models, conservation programs and limits to management. *Animal Conservation*, 15(4), 331-333.

Ojeda-Martínez, C., Casalduero, F. G., Bayle-Sempere, J. T., Cebrian, C. B., Valle, C., Sanchez-Lizaso, J. L., . . . Falcón, J. M. (2009). A conceptual framework for the integral management of marine protected areas. *Ocean & Coastal Management*, 52(2), 89-101.

Reopanichkul, P., Schlacher, T. A., Carter, R. W., & Worachananant, S. (2009). Sewage impacts coral reefs at multiple levels of ecological organization. *Marine Pollution Bulletin*, 58(9), 1356-1362. doi:10.1016/j.marpolbul.2009.04.024

Rogers, C. S., & Garrison, V. H. (2001). Ten years after the crime: Lasting effects of damage from a cruise ship anchor on a coral reef in St. John, US Virgin Islands. *Bulletin of Marine Science*, 69(2), 793-803.

Schlöder, C., O'Dea, A., & Guzman, H. M. (2013). Benthic community recovery from small-scale damage on marginal Caribbean reefs: An example from Panama. *Bulletin of Marine Science*, 89(4), 1003-1013.

Short, F. T., & Wyllie-Echeverria, S. (1996). Natural and human-induced disturbance of seagrasses. *Environmental Conservation*, 23(01), 17-27.

State of Alaska Department of Environmental Conservation. (2000). Cordell Bank National Marine Sanctuary, Management Plan. Retrieved from <http://bit.ly/2dLnYfR>

The Nature Conservancy and Grenada Fisheries Division (TNC GFD; 2007). Sandy Island/Oyster Bed Marine Protected Area, Management Plan, USVI

Thur, S. M. (2010). *User fees as sustainable financing mechanisms for marine protected areas: An application to the bonaire national marine park. Marine Policy, 34(1), 63-69. doi:10.1016/j.marpol.2009.04.008*

Tobago Cays Marine Park (TCMP; 2014). Sea Turtle Monitoring Presentation 2014.

Tseng, Y., Kyle, G., Shafer, C., Graefe, A., Bradle, T., & Schuett, M. (2009). *Exploring the crowding– satisfaction relationship in recreational boating. Environmental Management, 43(3), 496-507. doi:10.1007/s00267-008-9249-5*

Caribbean Environmental Health Institute (CEHI; 2004). A Directory of environmentally sound technologies for the integrated management of solid, liquid and hazardous waste for SIDS in the Caribbean Region. United Nations Environment Programme (UNEP). Retrieved from <http://bit.ly/2e6aWNa>

Walsh, J. C., Wilson, K. A., Benshemesh, J., & Possingham, H. P. (2012). *Integrating research, monitoring and management into an adaptive management framework to achieve effective conservation outcomes. Animal Conservation, 15(4), 334-336. doi:10.1111/j.1469-1795.2012.00579.x*

Walters, C. J., & Hilborn, R. (1978). *Ecological optimization and adaptive management doi:10.1146/annurev.es.09.110178.001105*

Whyte, B. 2012. *Grenada SIOBMPA Business Plan. Gulf of Caribbean Fisheries Institute.*

United Nations. (UN; 2014). *Proposed areas for inclusion in the SPAW list. Annotated format for presentation report for: Tobago Cays Marine Park, Saint Vincent and the Grenadines (United Nations Environment Program) (p. 38).*

Willette, D. A., Chalifour, J., Debrot, A. O., Engel, M. S., Miller, J., Oxenford, H. A., . . . Vedio, F. (2014). *Continued expansion of the trans- atlantic invasive marine angiosperm halophila stipulacea in the eastern caribbean. Aquatic Botany, 112, 98-102.*

Willette, D. A., & Ambrose, R. F. (2009). *The distribution and expansion of the invasive seagrass halophila stipulacea in dominica, west indies, with a preliminary report from st. lucia. Aquatic Botany, 91(3), 137-142. doi:10.1016/j.aquabot.2009.04.001*

List of Referenced Personal Communication

Aaron Bartholomew: Park Ranger, Sandy Island Oyster Bay MPA

Simon Carey: Former director of Tui Marine

Emma Doyle: Gulf and Caribbean Fisheries Institute

Marina Fastigi: Carriacou coordinator for KIDO Nesting Sea Turtle Monitoring, affiliated with WIDECAST

Berris Little: Mustique Marine Conservation Area

David Robin: Director of Maritime Administration, St. Vincent and the Grenadines

George Schmitt: Owner and operator of Arawak Dive, Tyrell Bay, Carriacou

Richard Laflamme: Owner and operator of Lumba Dive, Tyrell Bay, Carriacou

Theirry Segond: Mechanical Engineer, Techniservicemarine

Benjamin Wilson: Park Ranger, Tobago Cays Marine Park

Kenneth Williams: Park Manager, Tobago Cays Marine Park

Appendices

Appendix A: Recommended Mooring Systems' Specifications

The recommended mooring system identification, location depth and recommended mooring components for new yacht moorings in the TCMP and SIOBMPA are specified in Table 2-4.

Table 2. Number, location, depth and recommended mooring system components of potential new yacht mooring systems northeast of Jamesby Cay, TCMP.

Mooring ID	Coordinate (Degrees Decimal Minutes)	Coordinate (Degrees Decimal Minutes)	Depth (ft)	Components
N1	12° 37.727'N	61° 21.543'W	>8	Halas with concrete block
N2	12° 37.710'N	61° 21.526'W	>8	Halas with concrete block
N3	12° 37.748'N	61° 21.531'W	>8	Halas with concrete block
N4	12° 37.731'N	61° 21.513'W	>8	Halas with concrete block
N5	12° 37.731'N	61° 21.489'W	>8	Halas with concrete block
N6	12° 37.753'N	61° 21.495'W	>8	Halas with concrete block
N7	12° 37.766'N	61° 21.515'W	>8	Halas with concrete block
N8	12° 37.781'N	61° 21.496'W	>8	Halas with concrete block
N9	12° 37.766'N	61° 21.475'W	>8	Halas with concrete block
N10	12° 37.743'N	61° 21.467'W	>8	Halas with concrete block
N11	12° 37.756'N	61° 21.445'W	>8	Halas with concrete block
N12	12° 37.779'N	61° 21.453'W	>8	Halas with concrete block
N13	12° 37.796'N	61° 21.473'W	>8	Halas with concrete block
N14	12° 37.813'N	61° 21.454'W	>8	Halas with concrete block
N15	12° 37.797'N	61° 21.437'W	>8	Halas with concrete block
N16	12° 37.774'N	61° 21.427'W	>8	Halas with concrete block
N17	12° 37.780'N	61° 21.404'W	>8	Halas with concrete block
N18	12° 37.804'N	61° 21.410'W	>8	Halas with

N19	12° 37.824'N	61° 21.431'W	>8	concrete block Halas with concrete block
N20	12° 37.845'N	61° 21.418'W	>8	Halas with concrete block
N21	12° 37.825'N	61° 21.400'W	>8	Halas with concrete block
N22	12° 37.810'N	61° 21.382'W	>8	Halas with concrete block

Table 3. Number, location, depth and bottom type of potential new yacht mooring systems south of Sandy Island, SIOBMPA.

N (yacht) NS (small boat)	N (Degrees Decimal Minutes)	W (Degrees Decimal Minutes)	Depth (ft)	Bottom Type	Components
N1	12° 29.066'N	61° 28.861'W	15	Sand Patch	Halas with concrete block
N2	12° 29.070'N	61° 28.883'W	13	Sand Patch	Halas with concrete block
N3	12° 29.046'N	61° 28.882'W	17	Sand Patch	Halas with concrete block
N4	12° 29.049'N	61° 28.904'W	10	Sand Patch	Halas with concrete block
N5	12° 29.030'N	61° 28.915'W	20	Sand Patch	Halas with concrete block
N6	12° 29.055'N	61° 28.935'W	28	Sand Patch	Halas with concrete block
N7	12° 29.035'N	61° 28.943'W	14	Sand Patch	Halas with concrete block
N8	12° 28.991'N	61° 28.952'W	25	Sand Patch	Halas with concrete block
N9	12° 28.967'N	61° 28.940'W	25	Sand Patch	Halas with concrete block
N10	12° 28.943'N	61° 28.950'W	25	Sand Patch	Halas with concrete block
N11	12° 28.948'N	61° 28.934'W	33	Sand Patch	Halas with concrete block
N12	12° 28.979'N	61° 28.851'W	45	Sand Patch	Halas with concrete block
N13	12° 29.000'N	61° 28.840'W	35	Sand Patch	Halas with concrete block
NS1	12° 29.120'N	61° 28.882'W	-	Rock/sand	Halas with epoxy embedded pin or small concrete block
NS2	12° 29.117'N	61° 28.894'W	-	Rock/sand	Halas with epoxy embedded pin or small concrete block
NS3	12° 29.118'N	61° 28.906'W	-	Rock/sand	Halas with epoxy embedded pin or small concrete block
NS4	12° 29.112'N	61° 28.920'W	-	Rock/sand	Halas with epoxy embedded pin or small concrete block
NS5	12° 29.107'N	61° 28.931'W	-	Rock/sand	Halas with epoxy embedded pin or small concrete block
NS6	12° 29.104'N	61° 28.943'W	-	Rock/sand	Halas with epoxy embedded pin or small concrete block
NS7	12° 29.099'N	61° 28.954'W	-	Rock/sand	Halas with epoxy embedded pin or small concrete block
NS8	12° 29.096'N	61° 28.968'W	-	Rock/sand	Halas with epoxy embedded pin or small concrete block
NS9	12° 29.092'N	61° 28.981'W	-	Rock/sand	Halas with epoxy embedded pin or small concrete block
NS10	12° 29.085'N	61° 28.995'W	-	Rock/sand	Halas with epoxy embedded pin or small concrete block
NS11	12° 29.080'N	61° 29.009'W	-	Rock/sand	Halas with epoxy embedded pin or small concrete block
NS12	12° 29.075'N	61° 29.021'W	-	Rock/sand	Halas with epoxy embedded pin or small concrete block

Table 4. Number, location, depth and bottom type of potential new yacht mooring systems north of Paradise Beach, SIOBMPA.

N (New yacht) NS (New small Boat)	Coordinate (Degrees Decimal Minutes)	Coordinate (Degrees Decimal Minutes)	Depth (ft)	Bottom Type	Components
N14	12° 28.408'N	61° 28.986'W	>8	Sand Patch	Halas with concrete block or manta and pin
N15	12° 28.431'N	61° 28.980'W	>8	Sand Patch	Halas with concrete block or manta and pin
N16	12° 28.413'N	61° 28.961'W	>8	Sand Patch	Halas with concrete block or manta and pin
N17	12° 28.438'N	61° 28.958'W	>8	Sand Patch	Halas with concrete block or manta and pin
N18	12° 28.420'N	61° 28.937'W	>8	Sand Patch	Halas with concrete block or manta and pin
N19	12° 28.380'N	61° 29.029'W	>8	Sand Patch	Halas with concrete block or manta and pin
N20	12° 28.385'N	61° 29.002'W	>8	Sand Patch	Halas with concrete block or manta and pin
N21	12° 28.388'N	61° 28.972'W	>8	Sand Patch	Halas with small concrete block or manta and pin
N22	12° 28.393'N	61° 28.946'W	>8	Sand Patch	Halas with small concrete block or manta and pin
N23	12° 28.407'N	61° 28.905'W	>8	Sand Patch	Halas with small concrete block or manta and pin
N24	12° 28.392'N	61° 28.887'W	>8	Sand Patch	Halas with small concrete block or manta and pin
N25	12° 28.455'N	61° 28.932'W	>8	Sand Patch	Halas with small concrete block or manta and pin
N26	12° 28.434'N	61° 28.917'W	>8	Sand Patch	Halas with small concrete block or manta and pin
N27	12° 28.466'N	61° 28.908'W	>8	Sand Patch	Halas with small concrete block or manta and pin
N28	12° 28.440'N	61° 28.894'W	>8	Sand Patch	Halas with small concrete block or manta and pin
N29	12° 28.418'N	61° 28.881'W	>8	Sand Patch	Halas with small concrete block or manta and pin

NS0	12° 28.404'N	61° 28.858'W	>8	Sand Patch	Halas with small concrete block or manta and pin
NS13	12° 28.329'N	61° 28.964'W	>8	Rock/sand	Halas with small concrete block
NS14	12° 28.328'N	61° 28.953'W	>8	Rock/sand	Halas with small concrete block
NS15	12° 28.336'N	61° 28.929'W	>8	Rock/sand	Halas with small concrete block
NS16	12° 28.340'N	61° 28.909'W	>8	Rock/sand	Halas with small concrete block
NS17	12° 28.349'N	61° 28.881'W	>8	Rock/sand	Halas with small concrete block
NS18	12° 28.355'N	61° 28.871'W	>8	Rock/sand	Halas with small concrete block
NS19	12° 28.361'N	61° 28.861'W	>8	Rock/sand	Halas with small concrete block
NS20	12° 28.365'N	61° 28.851'W	>8	Rock/sand	Halas with small concrete block
NS21	12° 28.370'N	61° 28.841'W	>8	Rock/sand	Halas with small concrete block
NS22	12° 28.377'N	61° 28.832'W	>8	Rock/sand	Halas with small concrete block
NS23	12° 28.385'N	61° 28.823'W	>8	Rock/sand	Halas with small concrete block

Appendix B: Photographs of Mooring Systems

Photographs were taken during the in-field assessment of the mooring systems within the TCMP and SIOBMPA. The following photos display typical and notable features and conditions of the mooring system components (Figure 28-37).

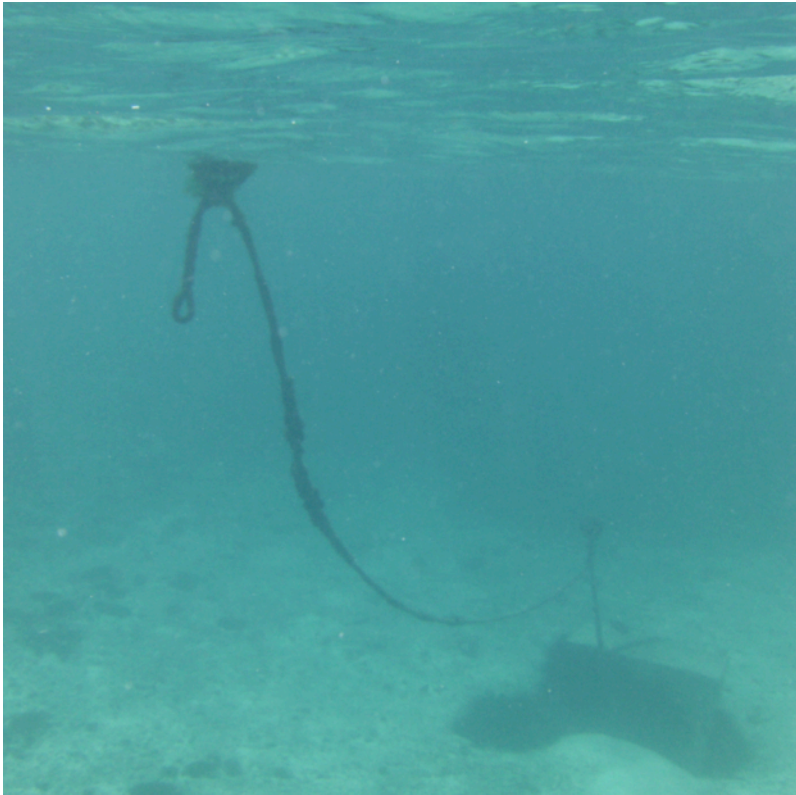

Figure 25. Image of the Halas mooring system with a pick-up line, buoy, through line, down line, float and concrete block anchor in the TCMP (Reed, 2016).



Figure 26. Image of manta and pin anchor with two pins, TCMP (Reed, 2016).



Figure 27. Image of downline with moderate fouling, TCMP (Reed, 2016).

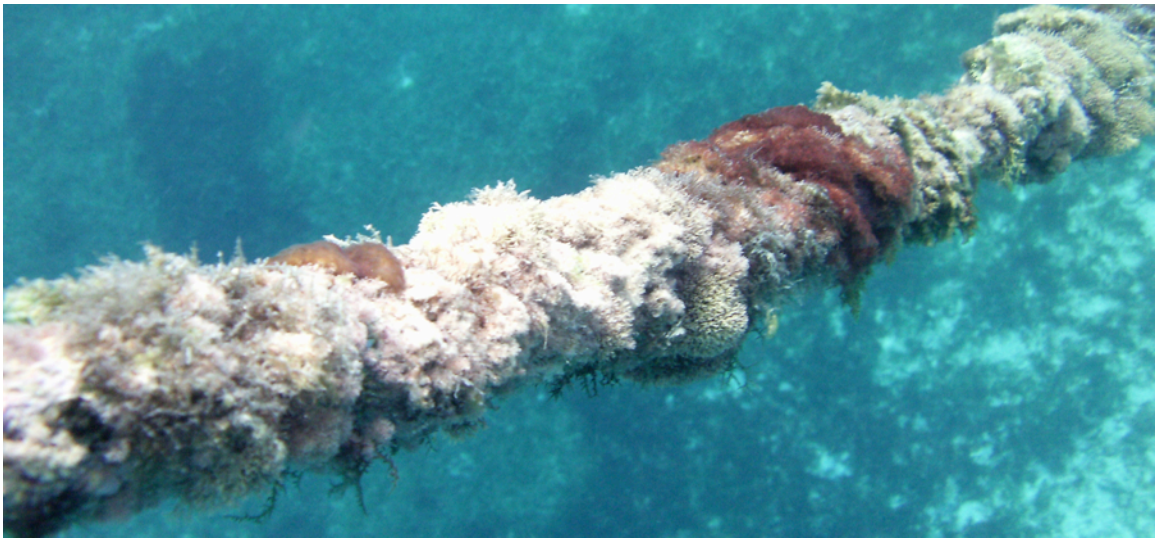

Figure 28. Image of downline with significant fouling, TCMP (Reed, 2016).



Figure 29. Image of the standard pick-up line with steel timble spliced into the looped rope to prevent abrasion, TCMP (Reed, 2016).



Figure 30. Image of the standard pick-up line with spliced rope loop reinforced with plastic piping to reduce abrasion from vessel lines (Reed, 2016).



Figure 31. Image showing a single manta pin anchor with downline attached, surrounded by seagrass and green algae (Reed, 2016).

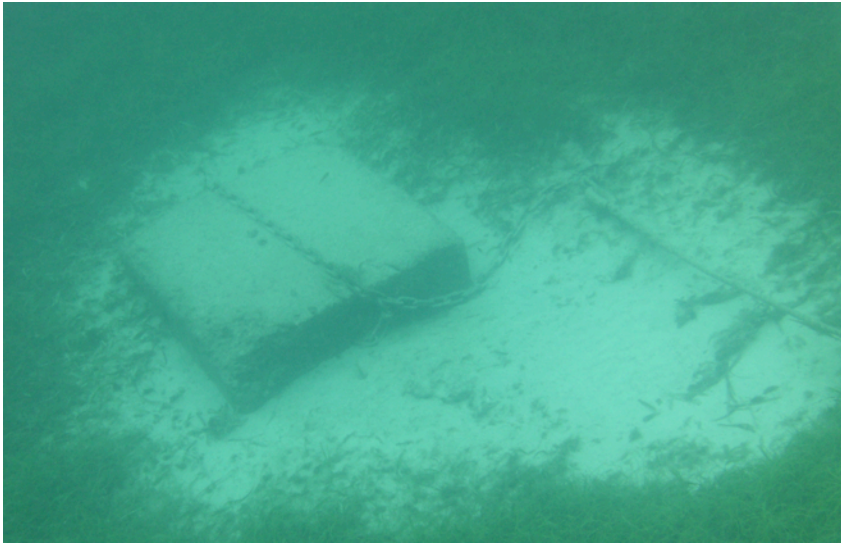

Figure 32. Image showing scouring of seagrass from anchor chain without a float, Salt Whistle Bay, TCMP (Reed, 2016).



Figure 33. Image (left) showing concrete block anchor with chain and float that is preventing scouring of the surrounding seabed, TCMP (Reed, 2016).

Figure 34. Image (right) showing a yacht anchor and chain that is damaging a seagrass bed, TCMP(Reed, 2016).



Figure 35. Image showing chain from yacht anchor lying on top of a seagrass meadow next to a conch (Reed, 2016)



x

Figure 36. Image of a pickup line being made with spliced rope and a loop reinforced with steel, TCMP office, Union Island, SVG (Reed, 2016).

Appendix C: Mooring Systems Management Materials

Appendix C.1 The Halas Mooring System

Excerpt from Fairhead and Baldwin, 2015

The Halas system of mooring design (Figure 1) has become very popular worldwide in marine parks areas due to its simple construction methods and practical maintenance costs. The Halas system generally uses a commercial 18-inch diameter buoy constructed from polyethylene plastic filled with polyurethane foam and treated with UV inhibitors. Embedded in the buoy is a PVC pipe through which a 3/4-inch buoy through-line can pass.

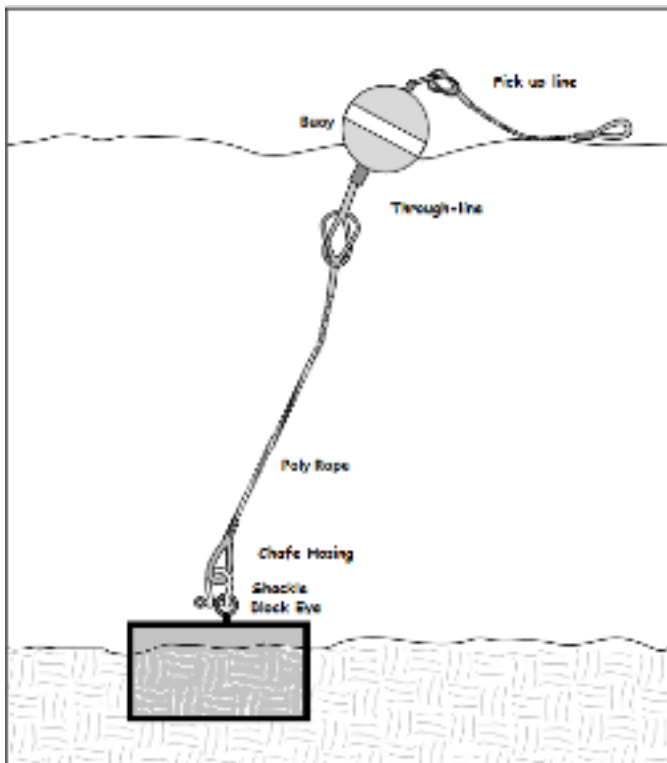

Figure 1. Typical "Halas" style mooring setup

Most of the materials used are easily sourced, simple to work with and local operators can become experienced enough to engage in regular and effective maintenance and repairs with very little training. Although the moveable mooring components generally remain the same for moorings using the Halas design, the anchoring system varies

considerably, depending on the nature of the seabed and intended use of the mooring (maximum vessel size limits etc.). Anchoring systems would typically be comprised of large concrete anchoring blocks in areas of sand and mud (silt), square shaft single or multi-helix sand screws in areas of deep sand, “Manta Ray” anchors in areas of sand or areas with a fairly hard composition and finally eye bolts that are drilled and epoxied into areas of hard coral or rock.

The Halas system is unique in that it uses a three-part rope system (Figure 2) instead of one continuous rope. One line leads from the anchoring system’s eye at the bottom to the buoy at the surface. A second line runs through the buoy and is attached with a loop to the anchor line at one end, and at the other end is attached with a loop to the third “pickup” line. This three-part rope system eliminates the need for shackles and thus decreases maintenance time and cost of the system. Maintenance is made easier because sections of the system can be replaced or repaired as needed without detaching the entire down line.

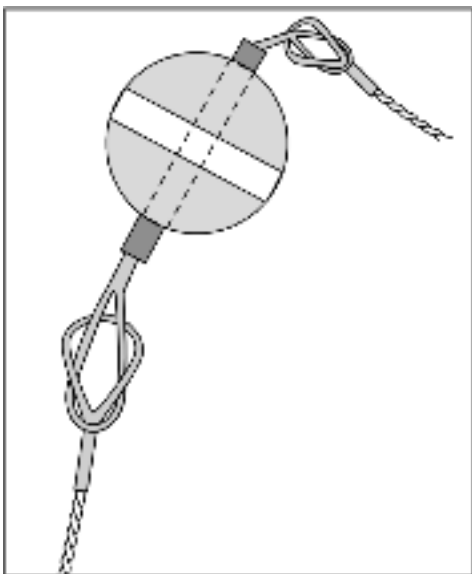

Figure 2. “Halas” 3-part system illustration

UV-treated polypropylene rope as well as 3-strand nylon “combo” rope is used for the three-part rope system. 3/4-inch rope is typically used for the down line and pickup line and 7/8-inch rope for the buoy through line, but vessel size limits would generally dictate the rope sizes required. A 3/4-inch nylon line, approximately 10 feet longer than the depth of the water at high tide serves as the down line. The length of the down line would

be adjusted for water depth and local tide conditions. At the bottom of the line a nylon reinforced hose or galvanized thimble is spliced into the loop to prevent abrasion and chafing from the bottom. This loop attaches with a shackle to the anchoring system's eye. The pin of the shackle is softer than the eye bolt so that the shackle wears out before the anchor's eye. An eye splice at the upper end interlocks with the eye splice of the buoy through-line. In some places tides and currents can twist the line and cause wrapping. This can be avoided by adding swivels to the bottom of the line.

The buoy through-line allows the buoy to be removed for repair without removing the entire down line. Twelve feet of 7/8-inch line is passed through the one-inch PVC buoy pipe. One loop is spliced into each end of the line; at the bottom end a 24-inch diameter loop large enough for the buoy to pass through, and at the top end, a small 6-inch diameter loop for attaching the pickup line. The splices should be as tight as possible to the buoy to prevent excess movement and wear on the line.

The 3/4-inch pickup line should only be long enough for a vessel to pick up and attach an additional line to it, approximately 15 feet of line for a 65-foot vessel. Additional line adds scope and resiliency to the system and, therefore, direct attachment of the pickup line to the boat should be discouraged. In other words, users should pass their own mooring line through the eye and pay out sufficient scope.

A galvanized shackle is used to connect the down line (and thus entire mooring system) to the anchoring system. Once attached, shackles should be properly tightened and seized. As mentioned above, various options are available for anchoring the mooring system to the bottom and these are generally determined by the nature of the seabed at the specific mooring site.

It is important to note that modifications to this system are acceptable and personal preference regarding the use of thimbles instead of the nylon re-enforced hosing, using a higher diameter line and eliminating the need for a pick-up line should be accounted for when setting standards for stakeholders to comply with.

Appendix C.2 Mooring Maintenance Schedule

The following maintenance schedule was recommended by Fairhead and Baldwin (2015) in the mooring management plan for the South Coast Marine Managed Area, St. Vincent and the Grenadines, which is a fellow member of the Grenadines MPA Network.

Weekly:

- Visual inspection of surface components of the moorings must be made during all regular patrols, at least weekly, or in response to public reports regarding moorings.

Monthly:

- Inspect all buoys and pick up lines.
- Clean pick-up lines of growth or replace if necessary.
- Clean, wax and polish buoys, check for cracks and replace where needed.
- Inspect and clean exposed portions of buoy through-line and replace if needed.

Quarterly:

- Inspect mooring down lines and chafe hosing for wear/damage and replace if needed.
- Inspect shackles for wear and damage, especially the contact area on the block's eye.

Bi-annually:

- Replace buoy through-lines.
- Replace mooring pick-up lines.
- Check for signs of anchor system movement/positional shifting.

Annually:

- Replace shackle pin.

Every 2 years:

- Replace entire down line if necessary.

Appendix C.3 Log Sheet for Mooring Inspection or Repair

The following is a template of the log sheet recommended for use to document the results of each inspection or repair of a mooring system within an MPA (Harvey, 2013).

Mooring Log Sheet

Inspection _____ Repair _____

Please use the following initial in the boxes provided to indicate the conditions of components and the work done on the specific date:

Good Condition (G) Needs Attention Soon (N) Replaced (R)

Date	Mooring No.	Pick-up Line	Buoy	Down Line	Shackle	Lock Wire	Anchor	Remarks

Note: Use the “Remarks” box to document any anomalies observed or document if and why a mooring was removed/abandoned.

Personnel Involved:

 Officer in Charge

Appendix C.4 Mooring Incident Report Log Sheet

It is recommended that the following log sheet be used to document incident reports.

Date	Reported To (Name)	Reported By (Name)	Mooring ID	Reported Incident or Issue	Signature of Mooring Supervisor

Appendix C.5 Mooring Management Binder Contents

It is recommended that the MPA patrol boats take a mooring management binder with the following contents on their rounds.

Mooring Binder Contents:

- ✓ Maintenance report log sheets (Appendix C.3)
- ✓ Map of moorings including ID numbers
- ✓ Maintenance procedures summary (Appendix C.7)
- ✓ Incident report log sheets (Appendix C.4)
- ✓ Mooring Fee Collection Checklist (Appendix C.6)

Appendix C.6 Mooring Fee Collection Checklist

- ✓ Boat name, size (gross tonnage and length), number of passengers, date, length of stay, mooring number and if the boat has a holding tank have been recorded
- ✓ Money has been collected and the amount recorded
- ✓ Mooring surface components have been checked
- ✓ Boat's connection to the mooring has been checked
- ✓ Boat's holding tank has been checked to ensure it is closed
- ✓ Visitors have been welcomed and briefed on park regulations and services
 - no-anchoring

- holding tank must remain closed
- speed limit
- proper garbage disposal
- no-touching or taking anything from the reef
- no fishing
- reef-friendly sunscreen
- contact information to report incidences (request that any issues with the moorings be reported; request that observations of other visitors breaking regulations be reported; offer assistance if anyone is harassing the visitor or theft occurs)

Appendix C.7 Summary of Standard Operating Procedures for Mooring Maintenance

The following summary was developed with the intent that it be included in the Mooring Management Binder to provide a reference material that can guide maintenance and promote consistency. The Standard Operating Procedures for Mooring Maintenance (Harvey, 2013) and the Moorings Plan for South Coast Marine Managed Area, St. Vincent and the Grenadines (Baldwin and Fairhead, 2015) were used to inform this summary.

Mooring maintenance involves a three stage cycle that ensures moorings are safe, reliable and in satisfactory condition. The main requirements of each stage are highlighted below.

Stage 1: Mooring Inspection

- ✓ Vessel is secured properly to mooring
 - boat's bow line should run through pick-up line and both ends of bow line should be cleated to the bow of the boat
 - pick-up line should not be tied directly to the boat
 - line should be lengthened on rougher days or if the buoy is pulled underwater and the line is horizontal
 - add an extra line during rougher conditions

- ✓ Vessel does not exceed the size or weight limit of the mooring system
 - small boat moorings accommodate dinghies and small boats under 25 feet
 - overnight yacht moorings accommodate yachts under 65 feet and less than 30 gross tons
- ✓ Mooring system surface components are in good condition and ID number is attached
 - weekly inspection of every mooring
 - check for fraying, breakage or other issues and remove biofouling
- ✓ In-water inspections are conducted by specially trained personnel only, in pairs if SCUBA diving
 - twice per month in high season
 - once per month in low season
 - clean ropes of biofouling, which could be masking damage
 - check for fraying, breakage, corrosion >20% on metal components (chains, shackles)
- ✓ Inspection Log Sheet is filled out and submitted to mooring supervisor
- ✓ A formal report is completed with each round of inspections and approved by Mooring Management Supervisor

Stage 2: Mooring Repair

- ✓ Repairs are conducted by specially trained personnel
- ✓ Repair activities are documented on a log sheet
- ✓ Changes to mooring supply inventory are recorded to ensure supplies used are restocked and funds are appropriately managed

Appendix C.8 Standard Operating Procedures for Mooring Maintenance

To implement the mooring maintenance cycle, it is recommended that the 15 Standard Operating Procedures (SOP) from the SOPMM be adopted (Table 5; Harvey, 2013).

Table 5. List of Standard Operating Procedures for Mooring Maintenance (Harvey, 2013).

SOP 1	All personnel working within the MPA must be familiar with the location and type of mooring infrastructure found in the MPA.
SOP 2	Each mooring must have a clearly marked unique identification number on the mooring buoy, which must be recorded on the official receipts.
SOP 3	All MPA personnel must be familiar with the size limitations of the MPA's moorings.
SOP 4	All MPA personnel must be familiar with proper mooring techniques.
SOP 5	Maintenance of moorings must be carried out under the supervision of the MPA manager or other qualified expert appointed by the MPA Board.
SOP 6	Inspections of underwater moorings components using SCUBA must be carried out by buddy pairs.
SOP 7	Personnel who are required to use specialist tools for mooring inspection and maintenance must first be trained in their use
SOP 8	Visual inspection of surface components of the moorings must be made during all regular patrols, or at least weekly, and in response to public reports regarding moorings.
SOP 9	In-water inspection of underwater mooring components must be made at least twice (2) per month in the high season and at least once (1) per month in the low season, and in response to public reports regarding moorings
SOP 10	If there is any fraying in the down or pick-up lines, corrosion of more than 20% of the metal (i.e. chain or shackles) or signs of stress fractures, these components must be replaced immediately.
SOP 11	Equipment and supplies must be kept in good order and in ready, operating condition.
SOP 12	Condition of moorings must be punctually and truthfully recorded following inspections. A field log sheet must be filled out for every mooring that is inspected and/or repaired.
SOP 13	All public reports about moorings must be followed-up and recorded in the ranger daily log.
SOP 14	All mooring reports must be validated and signed-off on by the senior ranger on duty and submitted to the manager.
SOP 15	In the event of a mooring failure or loss of a mooring, in addition to the mandatory incident report, a mooring failure report must be generated within one week and must include the details in the full SOP document

Appendix C.9 Recommended Colour Coding for Mooring Systems

The following colour code system is used in the British Virgin Islands and is recommended for use in the TCMP and SIOBMPA.

- The mooring buoys are 13 inches in diameter and are colour-coded as follows:
 - Orange Buoys: Non-diving, day use only
 - Yellow Buoys: Commercial dive vessels only
 - Large Yellow Buoys: Commercial vessels or vessels over 55 ft.
 - White Buoys: Non-commercial vessels, for overnight use (in BVI, only day use because boats are not allowed to overnight within MPA boundaries)
 - Blue Buoys: For dinghy use only

Appendix D: Details on Biogas-Biofertilizer Plants

Anaerobic digestion of sewage waste involves the use of bacteria to breakdown the organic material in the absence of oxygen. The process produces biogas and digested slurry. A biogas-biofertilizer plant, utilizes anaerobic digestion to degrade organic wastes, such as sewage, wastewater, animal waste, and plant waste, over a period of approximately 30 days (CEHI, 2004).

As the bacteria break down the organic material, biogas comprised of methane and carbon dioxide is produced and collects in the dome of the digester. An outlet pipe connects to PVC pipelines that transport the gas to be scrubbed and provided to various energy consuming devices (e.g. refrigerators, stoves, diesel engines). When the capital and operating costs of a digester were considered against the cost of conventional fuels, the comparisons showed that biogas may be a feasible alternative when (1) biogas can replace a conventional fuel, (2) the conventional fuel is more expensive than the biogas, and (3) all of the produced biogas is used (Homan, 2016).

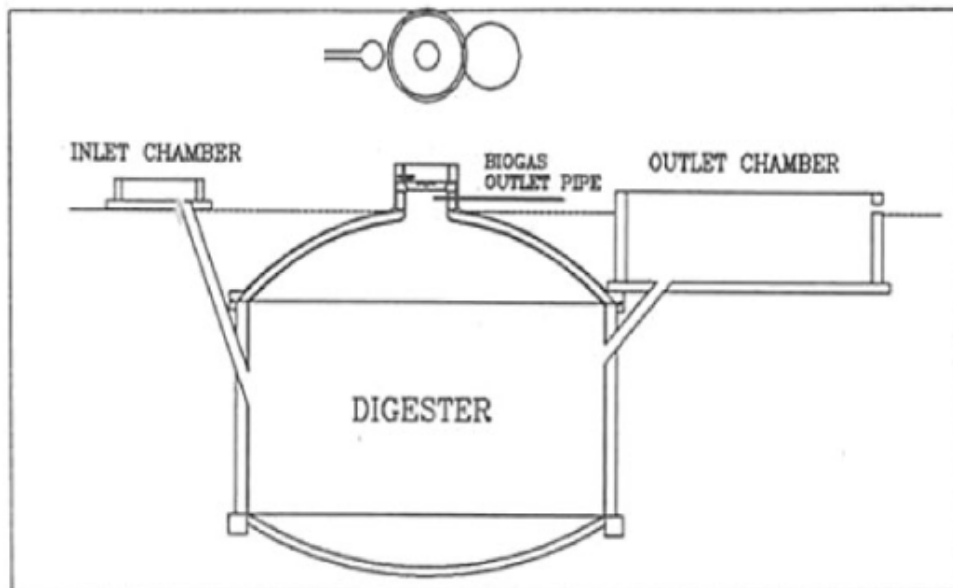

Figure 37. Diagram of a biogas-biofertilizer plant showing inlet chamber, digester, biogas outlet pipe and outlet chamber (CEHI, 2004).

Digested slurry is contained in the system's outlet chamber until it is piped to fields or dried and transported to the point of use. The slurry is a great fertilizer because it is rich in organic nutrients and typically does not contain harmful pathogens (CEHI, 2004; Jenkins, 1999). This technology does not work well with only human waste because it contains too much nitrogen and not enough carbon to adequately sustain the microorganisms (Jenkins, 1999). The system would therefore require a carbon-based material, such as plant cellulose, to be incorporated. Kitchen food-scrap, weeds, straw, hay, and leaves are sources of carbon that can be added to the system to achieve a beneficial carbon/nitrogen ratio. The need for carbon-based material could instigate the development of a composting system for the island.