

# **Go Skateboarding: Sculpting Form and Landscape for Inclusive Connection in Halifax's Urban Core**

by

Stefan Gagnier Ruckert

Submitted in partial fulfilment of the requirements  
for the degree of Master of Architecture

at

Dalhousie University  
Halifax, Nova Scotia  
June 2023

Dalhousie University is located in Mi'kmaq'i,  
the ancestral and unceded territory of the Mi'kmaq.  
We are all Treaty people.

© Copyright by Stefan Gagnier Ruckert, 2023

# Contents

Abstract .....	iv
Acknowledgements .....	v
Chapter 1: Introduction .....	1
Chapter 2: Space, Transparency, Disjunction .....	6
The Marks of Control .....	6
For/Against Skateboarding: Contemporary Design (Failures).....	11
Halifax, Nova Scotia: Reconciling a Relationship of Friction .....	13
Chapter 3: What is Skateboarding? A Global (R)evolution.....	15
History: Skateboarding, Built Forms, and Terrain for Creative Play .....	15
Skate and Destroy: Subculture, Pop-culture, Skate-culture and “Authenticity .....	18
Skate and Create: Art, Sculpture, and Kinetic Performance.....	20
Chapter 4: Empowerment and the DIY Ethic.....	25
Towards Inclusivity: An Authentic Return to Roots.....	25
Core Values and Spaces of Connection .....	26
DIY Skateboard Space: Constructing Social Sculptures .....	28
Chapter 5: Skateboarding and the City: A Dialogue of Urban Spatial Use .....	34
Precedents of an Integrated Future.....	34
Ciclovía: Reimagining the Status Quo of Urbanism.....	34
Cohabitation: Project Play! in Bordeaux .....	36
Dots, Spots, and Hubs: Urban Strategy for a Skateable Halifax .....	39
Landscape As Flow: St. Stephen’s Elementary .....	53
Enhancing the Existing: Le Marchant St. Thomas School.....	55
Let Them Build: Bloomfield DIY .....	64
Objects of Agency: A Kit of Parts for Assembly and Reassembly.....	68
Chapter 6: Riding Modern Art: Designing Between Space, Form, and Movement .....	75
Chapter 7: Modular Objects of Skateable Desire .....	83
Chapter 8: Design Proposal - A Network Hub at the Halifax Common Skating Oval .....	94
Selecting Site.....	94
Program .....	96
Courtyard: Hardscaped Sculpture Garden .....	102

Social Hub: Cafe + Bar Space.....	104
Learning Lab: Group Meeting and Teaching Space .....	107
Gallery .....	110
Chapter 9: Conclusion .....	116
References .....	128

## **Abstract**

In many cities, skateboarding is treated as a nuisance; a lack of understanding surrounding its positive reality inhibits its space within the city and prevents meaningful investment or consideration at the municipal level. Contrary to the male-dominated, risk-centric narrative that skateboard media portrays, skateboarding can be and is widely utilized as a tool for empowerment, community, and creative self-expression. Accepting skateboarding as an intrinsic part of urban public space (and designing for it as such) allows skateboard spaces to become focal points of accessible community at a time when skateboarding is growing and diversifying to include more women, LGBTQ2S+, BIPOC, and other typically marginalized demographics. This thesis presents a dialogue between art, sculpture, form, and movement that shifts the lens surrounding skateboarding and creates a network of multifunctional and user-interpretive skate spaces across peninsular Halifax, Nova Scotia - connecting the city physically, socially, and culturally.

# Acknowledgements

While this thesis document feels long, it is dwarfed by the mountains of love and support that made writing it possible for me. First and foremost: thank you to my parents. Your unconditional support throughout my life is what made me who I am, and you've been my greatest teachers.

To my wonderful committee (Christine, Sarah, and Peter): your advice, patience, experience, and perspectives were invaluable, and allowed me to achieve something that I'm truly proud of.

To the School of Architecture and the generous donors behind the Bruce and Dorothy Rossetti Travel Scholarship: thank you. My month-long exploration of Barcelona via skateboard was invaluable in determining which direction to take my thesis, and it was also the highlight of my time at this school.

To my cohort, with whom I've shared long nights and much laughter: thank you for inspiring me and for making this chapter of life such a memorable one. We did it!

To Abbi: thanks for being you, and for your endless patience, advice, support, and love.

To all the skaters around Halifax and beyond: thank you all the fun sessions and for engaging in this project with me. Big thanks to Jer Hawkins for all of the hours of help gluing up and moving around the wooden behemoths.

To Regan Southcott: thank you for expertise, patience, and investment in my (sometimes) ridiculous ideas. I've learned so much from you over my time at this school, and you made this project possible.

To Ken Kam: thanks for being such a pillar of excellence, and getting me to the finish line.

And to Dave Norwell: thanks for gifting me that first beat-up wooden toy so many years ago.

## Chapter 1: Introduction



A skater pushes on Citadel Hill, Halifax.

This thesis was born out of an accumulation of experience riding a skateboard. Since my first introduction to skateboarding around the age of ten, its playful experience has woven a common thread throughout my life over the last 18 years. It has opened countless doors of opportunity, built many of the most significant friendships in my life, and laid a positive foundation for most (if not all) of the skills

that now aid me in the field of architecture. The study of architecture sparked me to reconsider my relationship with skateboarding, and contrast it against the (often prevailing) backdrop of “NO SKATEBOARDING” signs and anti-skateboard architecture that too often permeates the core of cities.

Skateboarding evolved simply: bored surfers attached roller skate wheels to wooden decks in an attempt to recreate the glide they experienced riding ocean waves. In the following decades, skateboards and skateboarders progressed, claiming public and private terrain like drainage ditches, backyard pools, and standard issue elements of the urban fabric for their own use. Ultimately, this alternative use of space (combined with a self-proclaimed anti-authoritarian attitude peddled by skateboard media) resulted in an image of skateboarding that warranted architectural devices to stop its practice in the city (the focus of Chapter 2: Space, Transparency, and Disjunction).

However, the reality of skateboarding is far more than its initial perception. Chapter 3: What is Skateboarding? A Global (R)evolution will unpack this perception, and explore how skateboard culture is a hotbed of creativity and expression. Aside from the act of riding a skateboard, the larger culture of skateboarding encompasses performance, art, photography, film, design, fashion, music, and architecture (to list a few). Presently, this culture of creative self-expression is widely used to create more inclusive and empowered communities: from LGBTQ+ youth to increasing literacy for school-aged girls in Afghanistan, skateboarding is increasingly a positive social force. Chapter 3 ends with the suggestion that designing public amenities for skateboarding means considering its broad artistic adjacencies.



Skateistan's Skate School in Phnom Penh, Cambodia provides programming accessible to all levels of literacy and ability, to creating a safe space for young people to develop relationships and skills that overcome deep social barriers to feed positive growth. (Skateistan 2023)

On top of its broad applications, skateboarding is an accessible activity. In comparison to other recreational activities or sports, its requirements are meagre: the only essentials are the skateboard and hard surfaces upon which to roll (which abound in cities). In the context of climate change and creating less-congested cities, this means that the skateboard has renewed importance as a mode of transit. It can easily be picked up and nested into other modes of public transportation (as well as accomplish social goals).

For skateboarding to become successfully integrated into our cities, it needs to be given opportunity - but current urban practices tend to prevent skateboarding rather than encourage it. In the context of municipal investments controlling the development of skateboarding amenities, this opportunity can only be realized by updating the image of skateboarding and its associated cultural practices.

I propose that shifting skateboarding's image requires three steps:

- 1) expanding the scope of what skateboarding is, and showing how its practice is a social good
- 2) broadening the perception of who occupies space within the activity to include a more diverse user group
- 3) demonstrating creative and effective ways that skateboarding can be integrated within urban public space.

Chapter 4: Reclaiming Space: Empowerment and the DIY Ethic explores how women have been organizing and creating space for their identity as female skaters for decades, during a time when the skateboard industry had no interest in promoting them. Recently, this tide has begun



to shift as female and LGBTQ+ skaters have mobilized a DIY ethos and social-media to raise their visibility in the skateboarding space. Similarly, precedents from skateboarding's DIY movement demonstrate how skaters are actually constructing social sculptures in addition to physical objects. The chapter finishes by documenting a fundraising skate-jam for a local organization at a skater-built DIY skatespace in Halifax, which raised money and equipment to provide access to skateboards for Halifax youth.

Chapter 5: A Dialogue of Urban Spatial Use: Strategies for a Skateable Halifax focuses on urban spatial use; in particular, it focusses on two good precedents that rethink the status quo in order to positively impact the community. In Bogotá, Columbia, the Ciclovía program sparked a global movement that used the bicycle as a medium for reclaiming existing public roadways, regularly transforming them into lively arenas for social interaction and healthy activities. In Bordeaux, France, a collaboration between cultural institutions and skateboarders resulted in a series of public sculptures that highlighted how skateboarders can peacefully and fruitfully share urban public space with other users. The bulk of the chapter outlines a strategy for incorporating skateboard space into peninsular Halifax, based on reasonable skateable distance and the city's future-growth plan. Various scales of intervention are included within the strategy to demonstrate the relative ease and low-cost of making great skateable spaces.



Ortiz Mariño (founder of the Ciclovía movement) during the first ever Ciclovía, Bogotá, 1974. At the time, the Ciclovía movement was a radical shift in how people thought about the potential of urban spaces. (Caro Tanco 2021)

Chapter 6: Riding Modern Art: Designing Between Space, Form, and Movement proposes a design method evolved from kinetic interpretations of masses, forms, and volumes. Using geometric minimalism as a driver, a playful process

of considered form-making first sets spatial relationships aesthetically, before revising them to meet functional goals. The process brings forth a schematic design for a building, which is expanded upon in Chapter 9.

Chapter 7: Modular Objects of Skateable Desire tests the design of a sculptural bench furniture. While the bench is at its most basic level a functional piece of street furniture, its “correct” configuration is undefined, and its pieces can be deconstructed into fragments of skateable terrain. The design is built at full scale, and then given over to a group of skaters, who continually assemble and disassemble the features into new configurations, unlocking unique potentials each time. In this way, the bench design is programatically layered; functionality, sculpture, performance, and social connectivity all intermingle through its use. These are the same drivers for the final design proposal.

Chapter 8: Network Hub at the Halifax Common Skating Oval outlines an architectural design proposal, comprised of a building, a courtyard, and a skate-plaza (the plaza is placed the center of the existing Halifax Common winter skating oval). The design ethos is consistent throughout all the spaces, centring around movement and providing opportunity for interpretation, spectacle, gathering, and enjoyment.

Chapter 9: Conclusion reflects on a design process that shares parallels to the act of skateboarding, evaluates the success of the proposal, and suggests areas for further research, development, or expansion.

## Chapter 2: Space, Transparency, Disjunction

### The Marks of Control

Urban environments are complex and dynamic arenas for the lives and rhythms they contain. However, their apparent transparency and inclusivity is illusory, since much space carries within it prescribed and discriminatory normative values of what users, functions, and potentials are appropriate (Lefebvre 1974). This is not a new concept in the urban realm. During segregation, cities were explicitly divided to uphold racial dominance. The segregated city was an egregious example of practices which still occur through a more veiled means: cities today still discriminate through their urban process (Dantzler 2021, Hayden 1980). The city speaks volumes, and its inhabitants – whether they are aware or not – are constantly listening.

As Lefebvre states, “capitalism is a power exercised over society as a whole ... over both institutions and ideas”; space, then, is not untouched, but rather a system that capitalist hegemony makes use of (Lefebvre 1974, 11). Even the terms we use to describe space – a room in an apartment, a public place, a cultural centre – correspond to specific uses that constitute a set of spatial practices to be expressed within that context (Lefebvre 1974, 16).

Just as capitalism dominates society, there are those who rebel against it. Historically, the Situationist International (or SI) was a prominent group of mostly French avant-garde artists, political theorists, and intellectuals who playfully critiqued capitalism and its “spectacle”, and worked to develop methods through which they could distance

themselves from its hegemonic reign. One of these methods was the idea of *dérive* (or “drift”), described by Ken Knabb in the following way:

In a *dérive*, one or more persons during a certain period drop their usual motives for movement and action, their relations, their work and leisure activities, and let themselves be drawn by the attractions of the terrain and the encounters they find there... But the *dérive* includes both this letting go and its necessary contradiction: the domination of psychogeographical variations by the knowledge and calculation of their possibilities. (Knabb 1980, 50)

It is easy to draw comparisons between the *dérive* and urban skateboarding, since both exist outside of the “appropriate” spatial practices defined by the capitalist norms which govern the city. As Iain Borden describes, skaters recombine body, board, and terrain, resulting in the reabsorption and reproduction of architecture and the notions encoded within it (Borden 1998, 197). Through its practice, skateboarding suggests that “pleasure rather than work, use values rather than exchange values, activity rather than passivity are potential components of the future” (Borden 2001, 178), at once upturning capitalist principles of production and threatening the power of its regime.

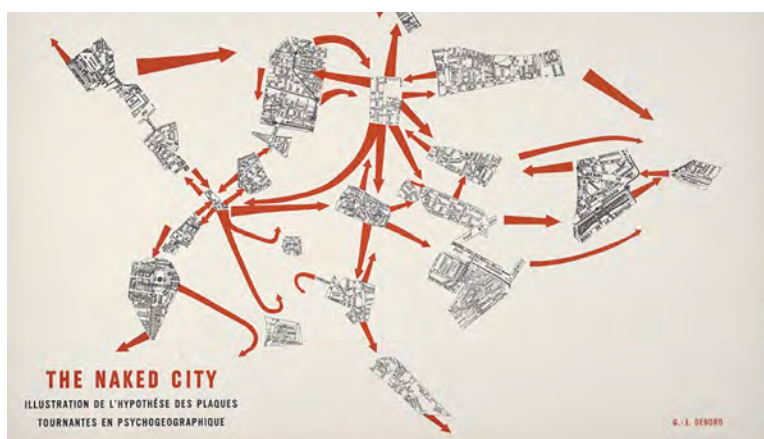

“The Naked City” by Guy Debord evolved from the practices of *dérive* and *détournement*, through which the Situationists reclaimed the city through playful critiques of capitalism and its “spectacle” (Debord 1957)

As a response to counter-normative uses of urban space, cities employ a number of mechanisms to deter skateboarding. These include signage forbidding its practice and “skatestopper” devices that limit the ability for skateboarders to smoothly ride, slide, or grind over the built forms which attract them. As Lefebvre describes,



Skateboarders upturn capitalist values of space through their “unproductive” uses of urban environments; the marks they leave are - in capitalist terms - marks of rebellion.

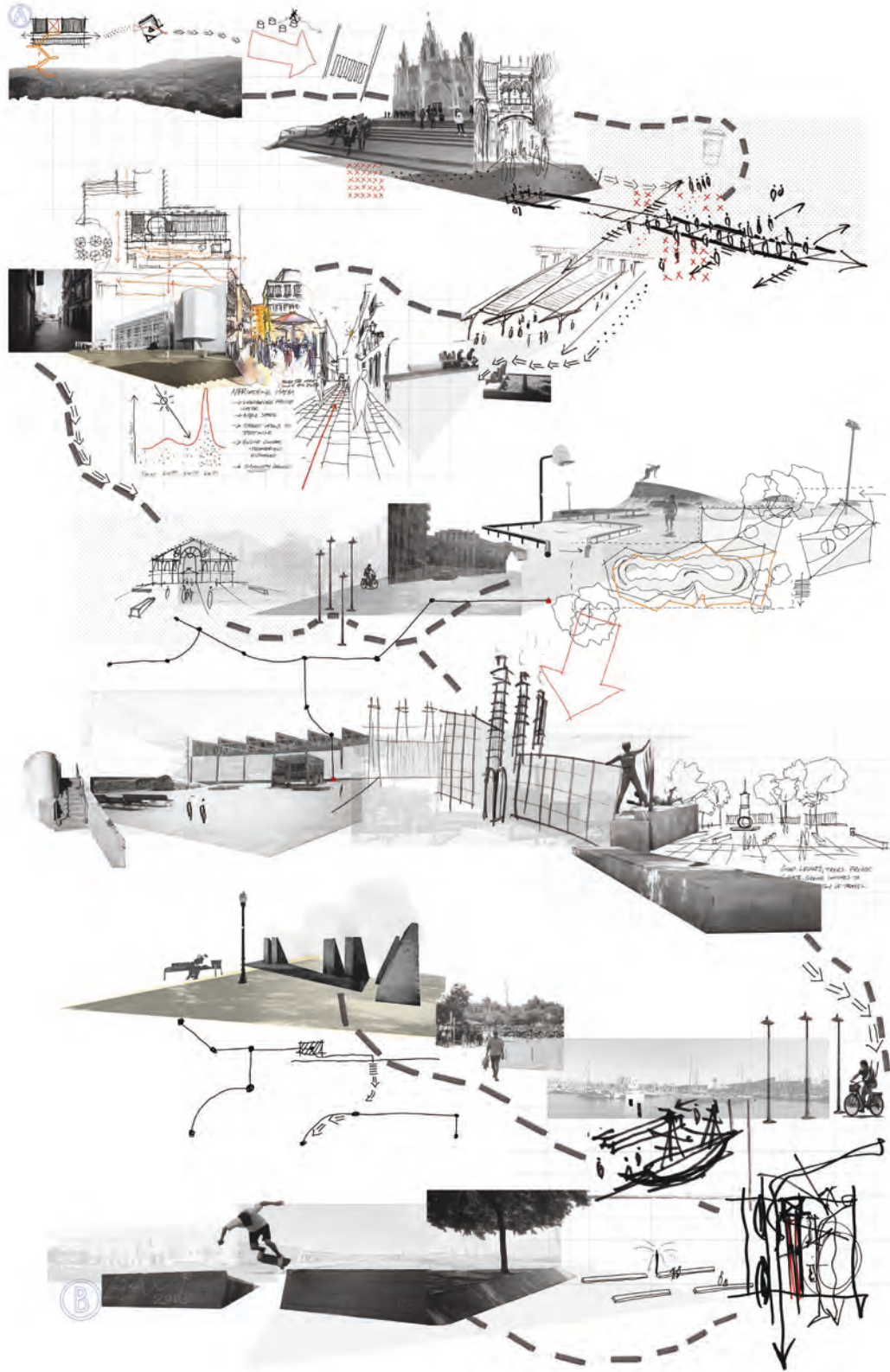

Drift 6: Barcelona 2022. Drifting through Barcelona via skateboard; an exploration of skateable terrain and its associated potentials.

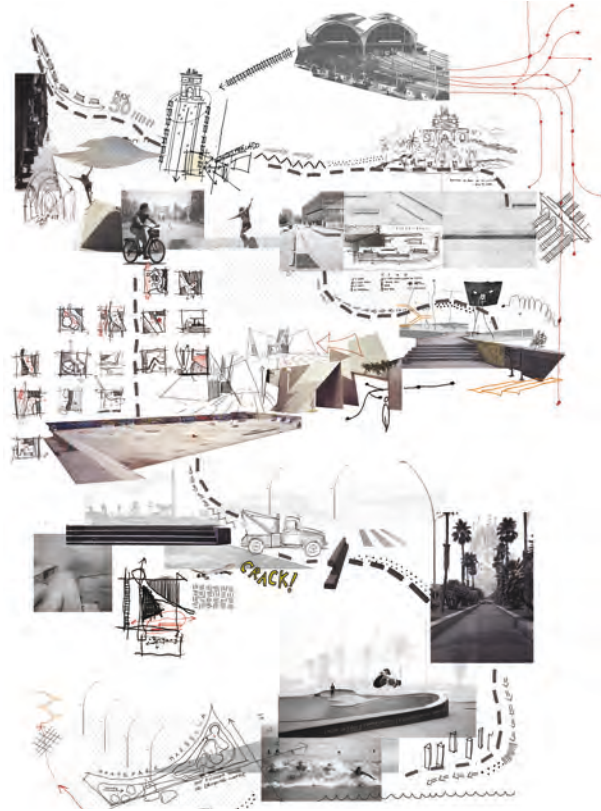

Drift 9: Barcelona 2022. Drifting through Barcelona via skateboard; an exploration of skateable terrain and its associated potentials.

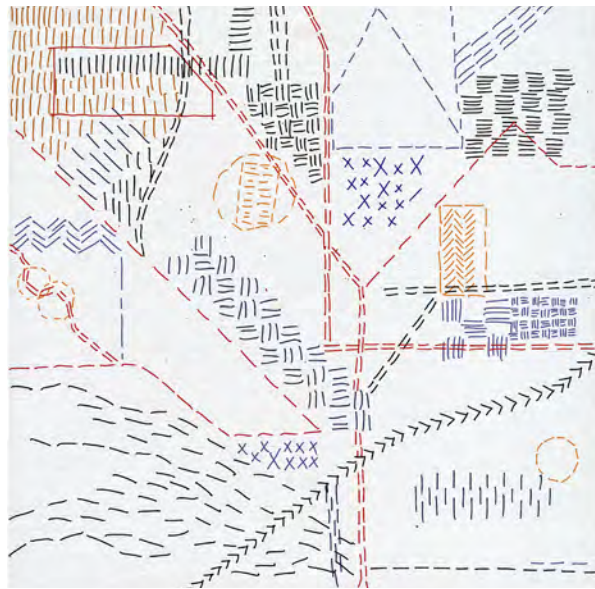

Ground study 4: Barcelona 2022. Drifting through Barcelona via skateboard; this particular study explores how different materials and surfaces affect the experience of skateboarding in the city.



“Skatestopping” devices are a design response aimed at limiting the ability of skateboarders to reappropriate urban terrain for their alternative use. (TGSi 2023)



A skateboarder slides atop metal balls meant to prevent skateboarding on an angled bank in New York City; the anti-skateboard devices inadvertently create a new (and no less appealing) challenge for skateboarders, who constantly adapt to the spaces that the city provides. (Thrasher Magazine 2023)

explicit communication through written language overrides the possibility of experiencing space as a social product, obscuring and ultimately aiming to destroy the potential existing within it (Lefebvre 1974, 27). Skatestopping devices communicate the same message: design is used to mediate and override the connection between mental activity (invention) and social activity (realization), exerting a force of control which considers not the interests of the user but instead the interests of the hegemonic system (Lefebvre 1974, 27-28). While signage and skatestopping devices directly oppose the physical actions of skateboarders in urban space, they also codify skateboarding as an unacceptable spatial use in the mental perception of other (uninvolved) users. Such anti-skateboard practices do more to tarnish the image of skateboarding than does skateboarding itself; either way, the result is that skateboarding – in contrast to the reality discussed in chapters two and three – finds a predominantly negative narrative in the urban discourse.

## **For/Against Skateboarding: Contemporary Design (Failures)**

### ***The Urban Machine***

What these anti-skateboard interventions fail to account for, however, is that the very essence of skateboarding is based around a culture of creative reinvention and reappropriation that allows skateboarders to adapt to the terrain surrounding them (whatever that may be). Sometimes, even skatestopping devices present new opportunities, integrating a new challenge into the space-body-board interaction (Irwin and Olpin 2006).



The city is unequivocally suited to skateboarding. The architectural diversity of form, material, and feeling combined with the social, temporal, and spatial fabrics of the city provide a superfluity of opportunity for skateboarder's constant creation and re-creation of space (Borden 2001, 181). As skateboard filmmaker Stacey Peralta states, "skaters can exist on the essentials of what is out there. Anything is part of the run. For urban skaters the city is the hardware on their trip" (Borden 2001, 180).

While skaters are dynamic, so is the city: every day, new skateable terrain is created with new urban development. This is the urban machine; it churns out space, and consequently opportunity for skateboarding. By 2050, the UN projects approximately 68% of humans to be living in urban areas (UNHBUF 2022); this means a projected increase of 2 billion urban dwellers – and the urban space that they require – in the next 30 years (UNHBUF 2022).

With skateboarding's user base consistently expanding from its current 50 million (Borden 2019, 1), it is inconceivable that any amount of skatestopping devices will ever curb the amount of new skateable terrain being created in cities. From this perspective, the design response of anti-skateboard devices is a failure; as quickly as they are applied, they are massively outpaced with new domain for skateboarding.

### ***Put Your Skateboard on a Leash***

Urban skateboarding primarily takes place within two main theatres: within the city itself (the space of exploration, or "street skating"), and within purpose-built municipal skateparks (the sanctioned amenity). While the presence of municipal skateparks is important, the concept of the skatepark as an island within a context of forbidden terrain

is inherently flawed. If skateboarding is forbidden in the city but allowed in only a specific area, the skatepark becomes another cog in a system of control – yet at the same time it fosters the skillset to move beyond its own bounds. As Leo Valls, a professional skateboarder and successful collaborator on skate urbanism with the City of Bordeaux, France, states:

a city like Bordeaux is very condensed, [there are] narrow streets... skateboarding is loud, so you get some people who complain about the noise, and they are like 'you guys have a skatepark, why don't you go to the skatepark? Skateboarding is forbidden in the streets, that's it.' But it's never going to work like that, you know. They think that by building skateparks, they are going to stop street skating - but that's not the case. When you build a skatepark, you actually create more street skaters. If you're 12 years old and they build a skatepark next to your house, you are going to start skateboarding. And two years later, [if] you open any skate magazine or [if] you are watching a skate video; [most of the time] it happens in the streets, which is the essence of skateboarding. So [this] idea of pushing skaters into specific terrains and forbidding skateboarding in the streets - it's not going to work. (Gabor et al 2019)

### Halifax, Nova Scotia: Reconciling a Relationship of Friction

Rather than prolonging an adversarial relationship, policy and design can instead collaborate to create strong community connectivity and spaces of inclusivity based around skateboarding (as will be evidenced in Chapter 5). However, In Halifax, Nova Scotia (the location of this thesis), skateboarding is illegal on public roadways (Province of Nova Scotia 2022) and fines for riding skateboards on both roadways and sidewalks are still enforced (Ellsworth and Leavitt 2017). Looking past this outdated legislation, it is easy to find examples of defensive architecture intent on excluding skateboarders throughout downtown Halifax and in suburban areas. The consequence of this treatment is that

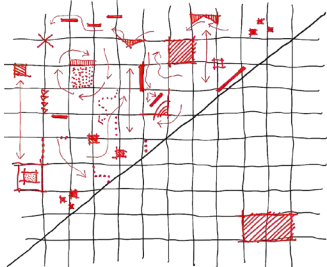

Reality vs. treatment: limiting skateboarding terrain to specific areas is inherently flawed, as the city offers the ultimate terrain.

skateboarders are given neither the space nor the chance to shift the negative narrative that the city perpetuates; instead, a negative narrative is subtly reinforced.

But just as skateboarding needs the city, the city needs skateboarding: Halifax needs skateboarding. Its Integrated Mobility Plan calls for “rethinking the design of [its] transportation system and the design of [its] communities,” aiming to counteract the trend towards car-centric transportation with active transportation and lively, human-scaled neighbourhoods and centres (HRM 2021a). Halifax’s Regional Plan aims to “strengthen community health and wellbeing, enhance equity and inclusion, and build on social assets and community capacity” (HRM 2021b). The position of this thesis is that skateboarding is a valuable means to achieve those ends, with the central question of: how can rethinking (and redesigning) what skateboard spaces are invert a negative narrative of urban skateboarding, incorporate multifunctional space for creativity into the city, and build accessible, diverse networks of social and physical connection in Halifax’s urban core?



A deeper understanding: shifting skateboarding’s perception from a singular image to a porous culture.

To answer this question, it is first necessary to gain an understanding of exactly *what* skateboarding is and *how* its narrative has evolved. Only then can skateboarding be effectively designed for and utilized toward these goals; this is the purpose of Chapter 3.

## Chapter 3: What is Skateboarding? A Global (R)evolution

I think skateboarding is a far more profound revolution than people give it credit for. The wonderful thing to me is that these young people discovered that they, themselves, would creatively adapt to the environment they already found and that it was their joy to adapt themselves physically to what was already there. - Edmund Bacon (Irwin and Olpin 2006)



Renowned Chicago architect and city planner Edmund Bacon rides a skateboard across LOVE park at age 92, in order to show his support for skateboarding taking place there. The plaza (a renowned but unsanctioned skateboard space) was redesigned in 2002 in an attempt to make it “unskateable”. (Van Allen 2013)

O’Connor (2017) describes skateboarding as “a subculture/ activity/sport with its own amorphous social field”. Understanding skateboarding as complex and nuanced is crucial to designing effectively and inclusively for it within the city, as well as to authentically appealing to its diverse variety of participants.

### History: Skateboarding, Built Forms, and Terrain for Creative Play

Skateboarding evolved in 1930’s California as bored surfers attempted to recreate the glide that they experienced in the ocean; steel roller-skates were rudimentarily attached to two-by-four planks, eventually to be replaced by short wooden decks around 20 inches long and 6 inches wide (Borden 2019, 7). Undergoing various technological advances through the next 30 years (most notably in the material of the wheels), skateboarders took over hills, roadways, and other banked terrain, transforming them into spaces of youthful play (Borden 2019, 9). By 1965, skateboarding had exploded as a small revolution in movement, with over 15 million US-wide practitioners and \$100 million in annual sales (Borden 2019, 9).

Since its inception, enacting new uses on urban terrain and reimagining the potential of built space has been a central characteristic of skateboarding (Borden 2019, 98). Skaters

searched out hard, smooth, flowing banked ground to ride upon; notably, California's drainage infrastructure offered prime terrain. LA County alone boasted over 2000 miles



A skateboarder rides on the smooth terrain of a drainage ditch in LA County, circa mid 1970s. (Holland 2019).

of tunnels and 150 basins and canals (Borden 2019, 99) which publications such as *Skateboarder* published photos of skaters interacting with. In turn, this sparked global emulation in Europe, Australia, and beyond.

Beginning in the mid-70s, images appeared in skateboard media of a new type of terrain: the concrete full pipe (Borden



A skater stands in front of a drainage pipe in the mid-1980s, which was constructed as part of the outflow infrastructure of a Southern Californian dam on Mt. Baldy. Infrastructure such as this created an iconic typology in skateboarding's history: the "full-pipe". (Burger 2018)

2019, 102). As extruded concrete circles intended for large-scale water movement, full-pipes allowed skaters an infinite back-and-forth flow as they used momentum to climb one side of the interior surface, turn, and ride down towards the other side. This found-terrain is still relevant and desirable in skateboarding today, and is often replicated in purpose-built skateboard parks around the world; the full-pipe inspired the half-pipe (likely the most recognizable skateboard terrain in the world).

The 1970s also mark the first time that curved backyard swimming pools were skated. Originally arriving in California by way of inspiration and replication of Alvar Aalto's kidney-shaped pool at Villa Mairea in Finland (Borden 2019, 106), the curved backyard pool was pivotal in the shift of skateboard culture away from surf culture (Borden 2019, 108). The evolution of carving, catching air, and landing again within a drained concrete pool was a wholly different experience than surfing, and led skateboarding into a status and classification of its own (Borden 2019, 108).

As skateboarding grew in popularity and scope, purpose-built skateparks began to appear that replicated the original found spaces of banks, ditches, pipes, and pools. Skateboarding also continued to progress, grow, and evolve, with modern skateboards providing the technology to expand domain back into new forms within the city. Modern skateparks now aim to replicate features like stairs, ledges, and handrails, in addition to the original banks and pipes.



Peter Hewitt "rock and rolls" the coping of a backyard pool, one of skateboarding's greatest found terrains. (Fick 2014)

I bring up this early history of skateboarding – particularly in pools – because of what it represents. Movement on a skateboarding is not simply utilitarian, nor is it rebellion: it is at once a creative exploration of space and terrain, an act

of performance and skill, a source of joy, and an expression of self. Five skaters together in the same space will draw neither the same lines of movement, nor execute the same tricks. Their performance is ultimately a hybrid between the emotional grace of dance and the intuitive, playful reactivity of jazz.

The spaces that a skateboarder chooses to interact with are spaces of individual attraction and expression. When a skateboarder chooses to invest time into a specific movement on their skateboard, the intimate connection between skater, terrain, and skateboard is a raw representation of identity. While this expression is individual, the experience is collective, earned, and relatable; hence it is a powerful means to bring people together.

### **Skate and Destroy: Subculture, Pop-culture, Skate-culture and “Authenticity”**

Skateboarding claimed the identity associated with it today – and defined its social space – through trespassing drainage ditches and backyard pools (Borden 2019, 113). This (unsurprisingly) often leads to confrontations, a narrative still common today as skateboarders search out privately and publicly owned terrain for their alternative use. Within skateboarding, freely reappropriating found space without obtaining permission to do so is often seen as “authentic” skate culture; the practice of street skateboarding (and its present popularity) relies upon this. The dominant media outlet within skateboarding – *Thrasher* magazine – promotes its authenticity through a mantra of “Skate and Destroy”, using skateboarding’s anti-authoritarian, sub-cultural roots to identify with an audience and form its brand.



Brianna Geering performs a crooked grind on a rooftop ledge, as seen on the October 2021 cover of *Thrasher* magazine. Reappropriating urban terrain not intended for skateboarding is a key part of “authentic” skateboard culture. (*Thrasher Magazine* 2022)

But while media plays an important role in skateboard culture, it also chooses what it portrays. The narrative of rebellion and counter-culture is actually just a small part of skateboarding’s holistic reality. In contrast to the closely guarded “core” values that skateboard media promotes, skateboarding has unequivocally entered the mainstream: the *Supreme* brand evolved from a boutique skateshop in New York into a billion-dollar street-culture superpower dressing skaters and celebrities alike; skateboarding breathed new life into the 2020 Tokyo Summer Olympic Games with heavily-televised “street” and “park” events; shoe companies Nike, Adidas, and New Balance all sit prominently within its realm; even *Thrasher* magazine recently collaborated on a clothing line with *Lacoste* (Lacoste 2022).

This leads to the question: if skateboarding is now a mainstream activity, why is the activity still associated with and dominated by young males?

Since the 1980s, the “authentic” image of skateboarding has been largely controlled by a structure of male, cis-gender industry leaders who have not provided an inclusive environment for anything or anyone existing outside of those norms, instead marginalizing women, trans, or queer identified people through a lack of support and representation (Beal & Ebeling 2019). Since the first issue of *Thrasher* in 1981, only 5 cover shots have pictured women out of the almost 500 issues published at the time of writing (*Thrasher Magazine* 2022). Academics who study skateboarding have pointed to the root of this discrepancy as being an intentional rebrand of skateboarding in the 1980s, which looked to weather an economic recession by appealing to a target market of teen males (Beal & Ebeling 2019; Atencio et al. 2018; O’Connor 2017). This strategy, although shifting



(Abulhawa 2020, 11) still rules over skateboarding. Any design for skateboarding should attempt to reconcile this relationship, and grow diversity within skateboarding.

### **Skate and Create: Art, Sculpture, and Kinetic Performance**

Skateboarding has a long history of connection with art and creativity; it is a creative culture that consumes, produces, and influences a wide variety of creative pursuits. In the 1970s, skateboard graphics shifted to the underside of decks where they were highly visible in photographs (Borden 2019, 242), and since then art and skateboarding have been inextricably linked. Some skateboard decks even reach collector status specifically because of their graphics (such as Jim Phillips' iconic screaming hand decks), while other graphics gain significance because of the acts performed atop them (such as the relatively plain BAKER Skateboards standard-issue decks, which skateboarders associate with a progressive era of modern street skateboarding).



Art and skateboarding are interwoven; board graphics can gain cultural significance, such as the iconic “Screaming Hand” deck designed by artist Jim Phillips. (Santa Cruz 2023)

Skateboard media plays a crucial role in disseminating skateboarding to a global audience (Borden 2019, 68), but also acts as a repository for skateboard culture; media forms a chronological record of skateboard history. Traditional printed magazines contain interviews, written prose, artworks, album reviews, maps, reporting, travel logs, and other stories in addition to their main content of skateboarding photographs (Borden 2019, 71). Skateboard films are another authentic means of capturing skateboard culture, and although often funded by corporate entities, the diverse stylistic qualities of skateboard films serve to create brand and team identities that often relate them more closely to art than documentation (Borden 2019, 84). Pontus

Alv, a professional skateboarder and well-known filmmaker describes the practice of making films as being

so much deeper and complex than just tricks, we are dealing with so many different subjects. Friendships, architecture, searching for spots, dealing with people, ups and downs in life and so on. I want to show all of life ... To have the freedom to do whatever the hell I want. To show whatever I want and use whatever I want. If I want to be naked in my films I can be; If I want to show a corpse I can etc. I love this freedom and I love to express my ideas without compromising. And ... to be able to show who I really am and what I stand for. (Theories of Atlantis 2014)

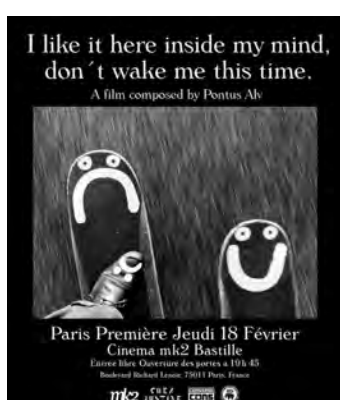

A premiere poster for a Paris screening of *I like it here inside my mind, don't wake me this time*, a film by one of skateboarding's most artistic filmmakers: Pontus Alv. (Alv 2016)

As Alv's quote implies, the portrayal of skateboarding – as well as its practice – is an expression of creative identity; skateboard films are outlets through which ideas, values, mediums and processes can be explored, communicated, and refined. Academy-Award winning director Spike Jones spent his childhood and adolescence riding, filming, and editing skateboarding videos (eventually creating some of the most influential skateboard films ever made) before ending up in Hollywood (Hammond 2016).

The terrain which skateboarders choose to ride is often sculptural and flowing; the early found terrain of curved pipes and concrete pools which skaters adapted for their own use is now recreated expressly for the purpose of skateboarding. When viewed out of context, concrete skateparks and bowls have a striking similarity to Noguchi's sculptural works; the unsanctioned guerilla terrain constructed by skaters themselves (known as DIY parks) are essentially interactive sculptures for their kinetic performance.

Similarly, the act of skateboarding has permeated the world of fine art. Early examples of shows like *Session the Bowl* at Soho's Dietch Gallery set a precedent for skateboarding as performance art (and actually inspired the iconic wooden bowls in Supreme's flagship stores) (Michna et al. 2022).

Japanese artist Takahiro Morita's project *Freehand* used a skateboard freshly dipped in wet paint to permanently capture the ephemeral traces of a skateboarder's movements around the floors and curved walls of an otherwise all-white gallery (Higai 2018). These two examples are part of a wide body of contemporary fine-art projects that are centred around the performative movement of skateboarders.

From its choice of terrain to its multitude of styles, tricks, and associated acts of creation, skateboarding is an artistic individual expression. Yet skateboard amenities (skateparks) typically give no latitude to their usage; they aren't reflective of the creativity inherent within skateboarding. Why should a quarter pipe – sculptural in its form – exist only within the confines of a skatepark? Conversely, why should a sculpture – an object of creativity – be an inappropriate place for an interactive and spontaneous act of performance? Why don't skateparks – places where people gather, exercise, socialize, and learn – include infrastructure that supports diverse sets of creative relationships and connection?

I propose that viewing skateboarding as an act of unbounded creativity and considering its many artistic faculties in a design process can result in an architecture that facilitates more than skateboarding in the singular; it can facilitate interaction, connection, and inspiration among diverse users (skaters and non-skaters alike) that move through the city everyday. Furthermore, publicly positioning skateboarding as an act of creativity makes it accessible to anyone looking to partake - not only the people who fit the "core" (and intentionally narrow) image that publications like *Thrasher* magazine sell. Public art is accessible, appealing, communal and stimulating; incorporating intentional spaces

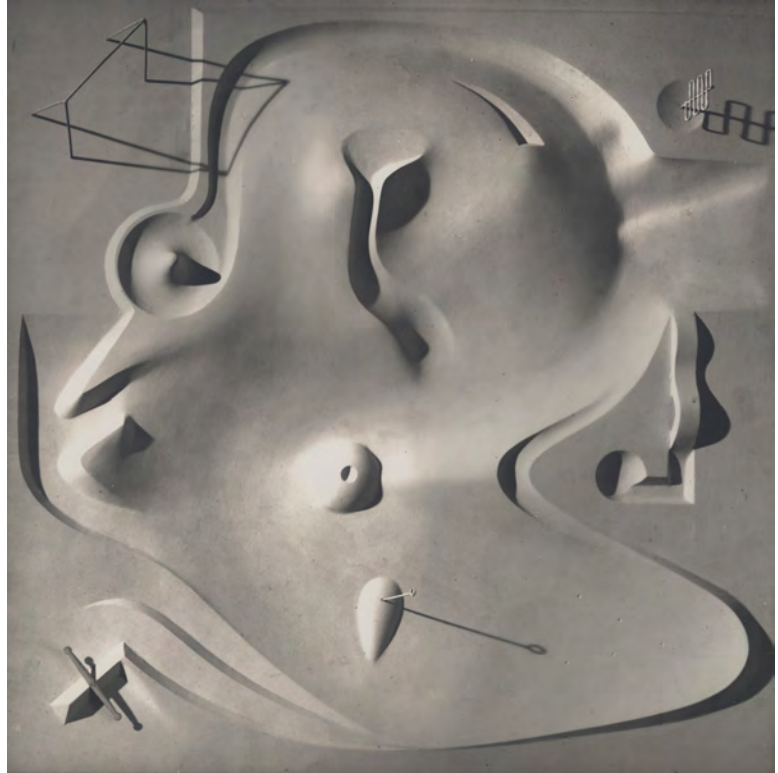

Skateboarders ride and play upon terrain that is akin to sculpture; this scale model for a playground design by Japanese sculptor Noguchi could easily be mistaken for a skateboard bowl. (Lincoln 2018)

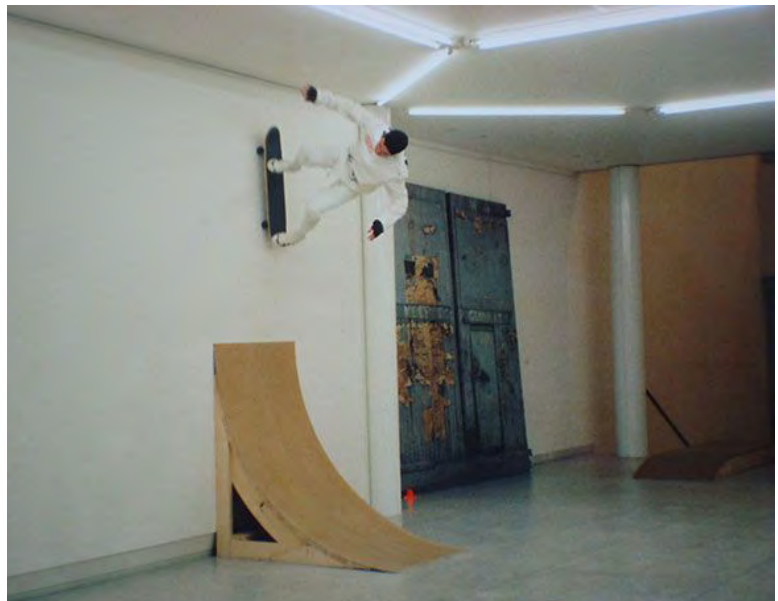

Skateboarding exists somewhere between the parameters of sport, performance, and art: Mark Gonzales performs a wallride as part of a 1998 exhibition with artist Johannes Wohnseifer at the Städtisches Museum in Monchengladbach, Germany. (Wohnseifer 1998)



A 2003 article in the Washington Post covers an art show at a SoHo gallery, an early example of live skateboarding being showcased formally as performance art. (Dietch 2003)

into the city that showcase skateboarding as a creative act of art and performance is a central tenet of this thesis.



Japanese artist Takahiro Morita's *Freehand* exhibition used wet paint to turn a skateboard into a brush, capturing the ephemerality of a skateboarder's movement. (Higai 2018)

## Chapter 4: Empowerment and the DIY Ethic

### **Towards Inclusivity: An Authentic Return to Roots**

During the late 60s and 70s, popular skateboarding styles centred around gender-neutral movements more akin to dancing or ice-skating than contemporary skateboarding practices (Abulhawa 2020, 19). As Stacey Peralta recounts:

Style was the most important thing ... You practiced maneuvers over and over and over again, because you wanted to get them connected to who you were. When you did a great Bertlemann turn, man ... it was a gesture of who you were. (Abulhawa 2020, 2)

Peralta's statement frames skateboarding as an expression of identity, ringing the same truth today as it did 50 years ago. The fundamental principles of skateboarding – style, elegance, creative movement – are not discriminatory, and are accessible and appealing to all types of humans (Abulhawa 2020).

Promisingly, modern skateboard culture is currently shifting to hold space and appreciation for self-expression (Beal and Ebeling 2019; Abuldawa 2020). In part, this is because the participation of typically marginalized or excluded demographics (such as women, LGBTQIA2S+, BIPOC) is growing to a level that it can no longer be ignored (Beal and Ebeling 2019; Abuldawa 2020). Corporate brands are reacting to the shift by creating media that celebrates and portrays skateboarding as an inclusive and accessible activity, highlighting the stories of women, queer, trans, or otherwise underrepresented demographics who found support, community, and empowerment within skateboarding (Charnoski & Nichols 2020; Cheng 2022). While still very much profit-motivated, these marketing campaigns are

proof that the target market of skateboarding (ultimately a reflection of its user base) has shifted to a broader and more diverse demographic. The proliferation of online media (which has largely replaced print-based media) also marks an important shift in which the audiences communicated to and messages surrounding skateboarding are evolving to reach people in new ways and new places.

Nora Vasconcellos, a prominent female professional skateboarder with a global following, sums it up nicely:

I think we're at a time where 12-year-olds at the skatepark have such a mixed bag of skaters that they're inspired by. And they don't even know it, because that's all they've ever known. It's been the most inclusive years [of skateboarding] so they're getting to really be nourished by the idea that everyone is welcome. (Roossin et al. 2023)

Skateboarding is unique in that there is no “right” way to do it. Ultimately, it is a subjective practice that gives the skater the power to determine what is fun, cool, or successful. At the same time, riding and tricking on a skateboard is a common baseline of struggles, failures, and fleeting successes that can instantly bond people together through shared experiences – regardless of language, gender, colour, or sexual identity.

### **Core Values and Spaces of Connection**

While skateboarding's diversity grows, the atmosphere of its traditional spaces often remains: the “Skate and Destroy” narrative pushed by *Thrasher* magazine has created an atmosphere of masculine competition around skateboarding, which in turn can toxify skateparks. Beal and Ebeling (2019) describe how skateparks can be exclusive spaces that are intimidating to beginners or outsiders of the social hierarchies within skateparks. Alexa Barriochoa, a sponsored transgender skater, confirms this:

growing up in Utah, I had no tangible reference point for what it meant to be transgender and still be a skater. The toxicity that dominated the skatepark was omnipresent; if you were anyone who existed outside the core identity groups that kind of ran the skateparks, there was an immediate response that that was negative. I would've never learned to skate if I'd come out back then. (Cheng 2022)

It is important to note that the way skaters can find each other and connect has changed recently. The growth of diversity within skateboarding can largely be attributed to the connection that social media has allowed, facilitating spaces and meet-ups for like-minded individuals to come together and find community (particularly with other skaters or those wanting to explore skating).

For Alexa, that connection came through an organization called Skate Like A Girl, where she was able to connect not only with other gender-diverse folks, but with her own identity as a skateboarder and a transwoman:

it really wasn't until coming to Seattle and seeing a dedicated space catered to and ran by people like me that I was able to make that connection and see that not only can I be involved in skateboarding as a transwoman, but that I can pass along a lot of the teaching that had been denied to so many of us for so long. (Cheng 2022)

For Alexa (and others), skateboarding was a means of connecting with and sharing an identity. Others find the same experience: a comment on a recent YouTube video profiling Alexa states that "I came out as trans about 6 months after I started skateboarding. I honestly believe skateboarding is what taught me the courage to do it" (Stevens 2023).

The attributes that skateboarding fosters – whether that be perseverance, grit, courage, or dealing with failure – are widely applicable life skills. But even beyond that, skateboarding teaches the ability to shift a perspective and open the mind to possibility. Where others may see only a



curb or a set of stairs, a skateboarder learns to see potential and possibility for play and expression. It widens the lens from what something *is* into what something *could be*; and it normalizes the idea that things existing outside of the status quo are to be embraced.

Mike Anderson (a professional skateboarder), describes the process:

Growing up skateboarding, it rewires your head. You don't want to take what's fed to you, you want to find your own path, you want to do your own deal. And if you don't have that, you can make it. Any traditional sport, you're caged in; there's a format, a formula. There's so many rules; everything stops because you stepped over a line; and everything stops because you grabbed the ball wrong ... Skateboarding is not just some one-object thing - you can do it anywhere that has concrete or asphalt. You're free - you're not confined to one zone, you're not trapped. There is no cage. (Hernandez et al. 2023)

Anderson's words can be taken literally or metaphorically – but at its core, skateboarding is a space where anything is possible.

With social media and connectivity, it is crucial now more than ever for accessible and inclusive skateboarding spaces to be provided within cities - including informal spaces outside of typical skateparks. As greater numbers of people begin to feel comfortable expressing their unique identities, ensuring that our cities are equipped to provide safe spaces for connection – as well as the freedom to explore and develop their own expression of self – is paramount.

### **DIY Skateboard Space: Constructing Social Sculptures**

Within skateboarding, there is a strong culture of “do-it-yourself” construction. Skaters build unsanctioned DIY skatespots and skateparks in abandoned or underused areas with their own labour and funds. These skater-

built spaces are considered more “authentic” than typical skateboard parks.

Most major cities have them, tucked away in out-of-the way or out-of-sight locations like under bridges (especially where rainy) or abandoned construction sites; notable ones are in Vancouver (Leeside), Portland (the original DIY, Burnside), San Pedro (Channel Street), San Diego (Washington St.), Montreal (Project 45). I have visited DIY skate spaces in almost every city that I have travelled to - wherever there is skateboarding, there is DIY. Several spaces exist within Halifax: on the peninsula, the de-facto DIY spot is Bloomfield, which exists on the cracked (but still smooth) pavement of the decommissioned Bloomfield Community Center.

DIY spaces have very different atmospheres from skateparks, and they are constantly evolving as new people become involved and and new features are built. In a sense, DIY spaces are physical expressions of self, and there is often a strong sense of community surrounding them. When a DIY is constructed, it is never in isolation; what it represents is a group of individuals coming together to better their collective circumstance.

Pontus Alv’s early Polar videos (the popularity of which helped put Sweden on the map as a global skateboard destination) featured many DIY spaces, and inspired a global movement of DIY spot construction. On the impact that showcasing the DIYs has had, Alv says:

when people send me pictures of DIY spots [that they build] because they saw my films and they got the motivation and energy from them, that makes me proud and it feels like I am giving something back to skateboarding - which is my main goal: to give back and inspire skateboarders from all over the world to make their own skateboard scene a better place. It call all be done with some bricks and cement bags. A DIY project is more than a spot; it brings people together

and it makes the scene stronger. It builds a social sculpture.  
(Theories of Atlantis 2014)

When DIYs are thought of as social sculptures rather than vandalisms, their presence begins to have meaningful value. As mentioned earlier, the atmosphere is different and more communal, which means that they attract beginners and



The culture of DIY spots in skateboarding involves transforming leftover spaces and materials into skateable terrain; skaters in Halifax gather granite slabs discarded from a building renovation in a garbage disposal area.



Skaters activate an out-of-commission tennis court with their own skateable constructions at the old Bloomfield Community Center site in Halifax, NS; the site is representative of the type of DIY-style constructions that are widespread within the skateboard world.

different types of skaters who typically feel uncomfortable at the skatepark.

To prove this point, the atmosphere of Bloomfield was one of the main reasons that a local skateboard organization chose to hold their annual fundraising jam there instead of the skatepark. *Renew*, a locally-run organization that collects old skateboard parts and assembles them complete in order to provide kids access to skateboards, chose Bloomfield as the site for their Trash to Treasure jam because it was a more inviting space, and people tend to feel more comfortable than the Common skatepark (J. Hawkins 2023, personal communication). Because of the informality of the space, kids and women felt comfortable skating amongst the men, rather than off to the side somewhere.



The informal atmosphere of the DIY spot creates a communal feeling often not found at typical skateparks, hence serving an important function in the urban skateboard scene.



Men, women, children, beginners, and experts: skaters of all types gathered at the Bloomfield DIY skateboard spot for a jam put on by a local skateboard association in Halifax, May 2023.



Skateboarding can activate the city in new ways: the unsanctioned constructions at Bloomfield not only provide consistent eyes on an unused space, but act as a foundation for social connectivity through skateboarding.

## **Chapter 5: Skateboarding and the City: A Dialogue of Urban Spatial Use**

### **Precedents of an Integrated Future**

What would happen if designers and planners viewed the urban environment through a skateboarder's lens? Could it influence the way that people move, or at least consider the potential of the environments surrounding them? I argue yes - quite easily: it doesn't take much digging to find precedents that exemplify the power of perspective - and the potential that comes with perspective shift - in an urban context.

### **Ciclovía: Reimagining the Status Quo of Urbanism**

Take Ciclovía, for example: the global movement that uses the bicycle as a medium for reclaiming existing public roadways, temporarily and consistently transforming them into lively arenas for social interaction. Originating in Colombia's capital city in the early 1970s and becoming integrated as a planning "best practice" in the 2000s, Ciclovía allowed Bogotá to shift its image from an urban dystopia and city of fear to a world model of planning in less than a decade (Montero 2017). Every Sunday of each week, 70 miles of highways and streets in Colombia's capital city are closed to car traffic from 7 a.m. until 2 p.m., and reserved for cyclists, pedestrians, wheelchairs, scooters, rollerskates, skateboards, or any other form of movement that is not motor-powered (Guillermoprieto 2019).

The result is astounding: about 1 million people flock to the streets of Bogotá to join in Ciclovía every Sunday (more than the whole population of Amsterdam), and its success

has inspired similar street closure programs across the globe in cities as diverse as Guadalajara, Jakarta, and Los Angeles, among more than 200 others (Montero 2017). And the Ciclovía is not just about cycling: people eat, run, nap, watch, play music, do tai chi or Zumba, flaneurs fill sidewalk cafes, food carts sell fresh fruit or hot food beside all sorts of people doing any sort of human-centric activity they can imagine (Guillermoprieto 2019). Bibiana Sarmiento, the director of Ciclovía, says that “...the most important thing is the social fabric that gets woven [among people who use] the Ciclovía ... our objective is to make citizens take over the city’s public space (Guillermoprieto 2019).

The Ciclovía also has the ability to transcend social stratifications, and to foster respectful dialogue between parties that usually find friction with each other: Sarmiento comments

no one cares about the clothes you’re wearing or what social class you’re from: everyone is welcome, and everyone is equal ... We see the change in behaviour: during the week if a policeman approaches to recommend a different conduct, everyone will answer [aggressively.] On Sundays, people will do as the policeman asks. On Sundays, citizens become tolerant. (Guillermoprieto 2019)

At its core, the idea of Ciclovía is that existing streets can be reframed into a new type of amenity; they don’t need to be monopolized by cars, but instead can be seized and reprogrammed into more healthy, human-powered and intrinsically social activities.

Skateboarders do this daily when they reappropriate urban terrain; but they often are met with aggression or intolerance because they are missing the type of shared connection with the general public that frames their spatial use as a positive act. This means that design for skateboarding should consider and engage with a larger demographic than



just skateboarders; good skateboard-centric design should attempt to incorporate *and* cater to the general public.

### **Cohabitation: Project Play! in Bordeaux**

Bordeaux, France, is a city with a vibrant skateboard scene. The architecture of the city – particularly many of its major cultural attractions – is especially ideal terrain; but skateboarding often found itself at odds with the planned programming of those spaces. Leo Valls, a well-known professional skateboarder from Bordeaux, talks about how many of his city's great skate spots were forbidden to skaters, but skaters would still skate them and risk receiving tickets with significant fines or skate them at night (Gabor et al. 2019). Eventually, the issue needed to be confronted by both sides; so the skaters formed an association and met with many of the major cultural players and museums with which they were having conflicts. Presentations were made, and the value of skateboarding as a form of expression and an artistic practice was communicated. The result was compromise on both sides: a concept for a schedule of specific times when skaters were allowed to skate in the cultural plazas. A trial period was implemented, and to the relief of both groups, it worked. The skaters respected the time frames because they appreciated the consideration they were given (an experience not common for them), and the city was willing to allow skateboarding because of the interest and life that it brought to cultural centers outside of their peak hours (Gabor et al. 2019).

There was also another benefit to the cultural centers. The collaboration led skateboarding to become the focus of several popular exhibitions, including a major installation of a skateboard ramp at the Bordeaux Museum of Modern Art,



Exhibitions to do with skateboarding at major museums were the catalyst for productive dialogue between skateboarders and municipal powers in Bordeaux.

and an exhibition of skateboarding in the city at the arc en rêve centre d'architecture that Art Director Michel Jacques cited as one of their best exhibitions ever (Gabor et al. 2019). Through such exhibitions and the social relationships created between skaters and institutions, skateboarding began to acquire a positive municipal image and the stage was set for further collaboration.

A year later, the mayor of Bordeaux called Leo Valls and outlined how his imagined city of the future would integrate an art like skateboarding into the fabric of the city – and he also recognized that such an integration should be led by skateboarders (Gabor et al. 2019). He invited Valls and the skateboard association to begin imagining what a skateable city of the future would look like (Gabor et al. 2019). The collaboration manifested itself in the creation of *Play!* : a route of different skateable sculptures throughout the city, which were designed with a unique visual language and identity that would bring skaters and non-skaters together in a collaborative dialogue (Gabor et al. 2019). The sculptures were installed at emblematic spaces within the city from June 21 to September 23, 2019, as part of “Liberté!” - Bordeaux Cultural Season 2019.

One of the sculptures, *Cohabitation*, is a ledge with a large flat surface on top (similar to a stage) upon which

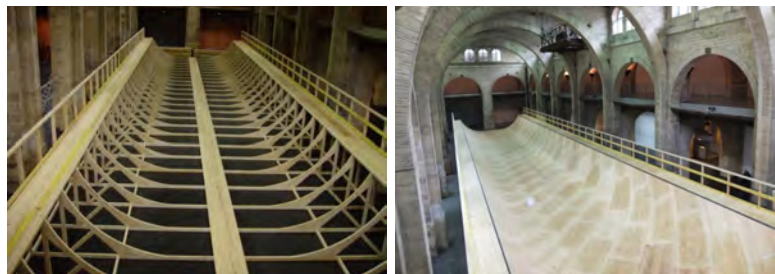

Pictured: “if we are dead, so it is” by Michel Majerus (a 164-foot long painted skateboard ramp) exhibited in 2012 at CAPC, Bordeaux. (BMCA 2012)

are positioned three chairs. The chairs are meant to be inhabited by members of the public, engaging them in a personal performance of skateboarding. Designed by Valls and artist Nicolas Malinowsky, Valls says that

The idea is to express the fact that we can all share the same object, all live in the same space, and cohabit [skaters and people who don't skate] ... and it's fine, it shows it's all ok ... the idea is that anyone can do whatever they want ... we are excited to see what is going to happen with the sculptures other than skateboarding. (Gabor et al. 2019)

Arielle Piazza, Bordeaux's Director of sports and youth, said about the Play! project:

Through this project of planning skateboarding within the city, the point was also to touch a necessary and societal need, which is about living together, sharing the city, and cohabitating it together. And for the mayor, it is very important that the youth take an active and equal role in the city. (Gabor et al. 2019)

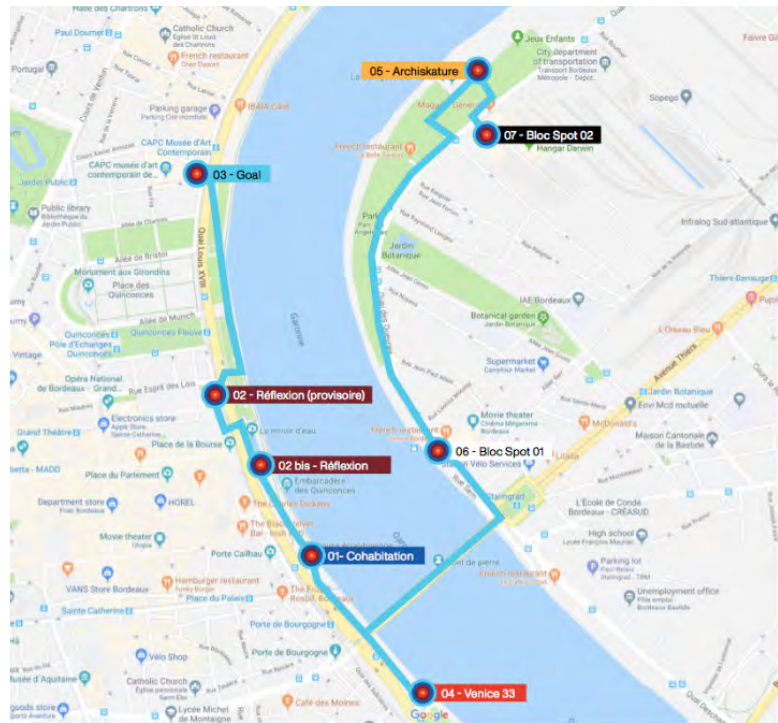

The *Play!* project was a collaboration between the City of Bordeaux, a local skateboard association and several artists that centred around a pathway of skateable sculptures meant to communicate skateboarders cohabitating the city with other users. (Dedication2Skate Design Agency 2019)



The *Play!* project included interactive sculptures that utilized a unique visual identity and skateable forms to facilitate interactions and engagement between skaters and non-skaters. (Dedication2Skate Design Agency 2019)

For Bordeaux, skateboarding is becoming a means to that end.

### **Dots, Spots, and Hubs: Urban Strategy for a Skateable Halifax**

The first step to developing an urban skateboarding strategy is having a thorough understanding of the practice. While skateboarding is versatile, it is also limited: a skateboard's

small wheels mean that skating long distances over rough ground is neither enjoyable nor realistic. Experience tells me that the ideal skateable distance over variable terrain is between 1 and 2 kilometers; anything further and a bike, car, or bus is preferred. As a skateboard can easily be carried onto a bus or train, integrating networks of skateable terrain within reachable distance of transit routes is a means of reducing car travel within cities - a central pillar of Vancouver's recent Skateboard Amenity Strategy (VDZ+A et al. 2022).

With this in mind, peninsular Halifax can be thought of in terms of skateable radii. Within each radius, a skate amenity of varying scale can be placed, connecting the city through a system of distributed points instead of a linear route (in contrast to a typical linkage like a bike path). Skateboarding has inherent qualities of discovery and exploration; a system of radial distribution affords the skater agency in determining their own path or destination within the city.

Layering Halifax's future growth plan, existing and proposed transit routes, active transit networks, and existing public amenity spaces and greenspaces with 1km radii circles shows how scattering 9 design interventions can effectively make peninsular Halifax a skateable city. From anywhere on the peninsula, a purpose-built skatespot will never be more than 1km away. This incentivizes riding a skateboard - both for the beginner who feels intimidated at the skatepark but wants to connect with other like-minded individuals, or for the person who was thinking about driving but likes the feeling of rolling up and down the bank a few times on their way to the bus stop. It also makes livelier, safer streets and neighbourhoods.

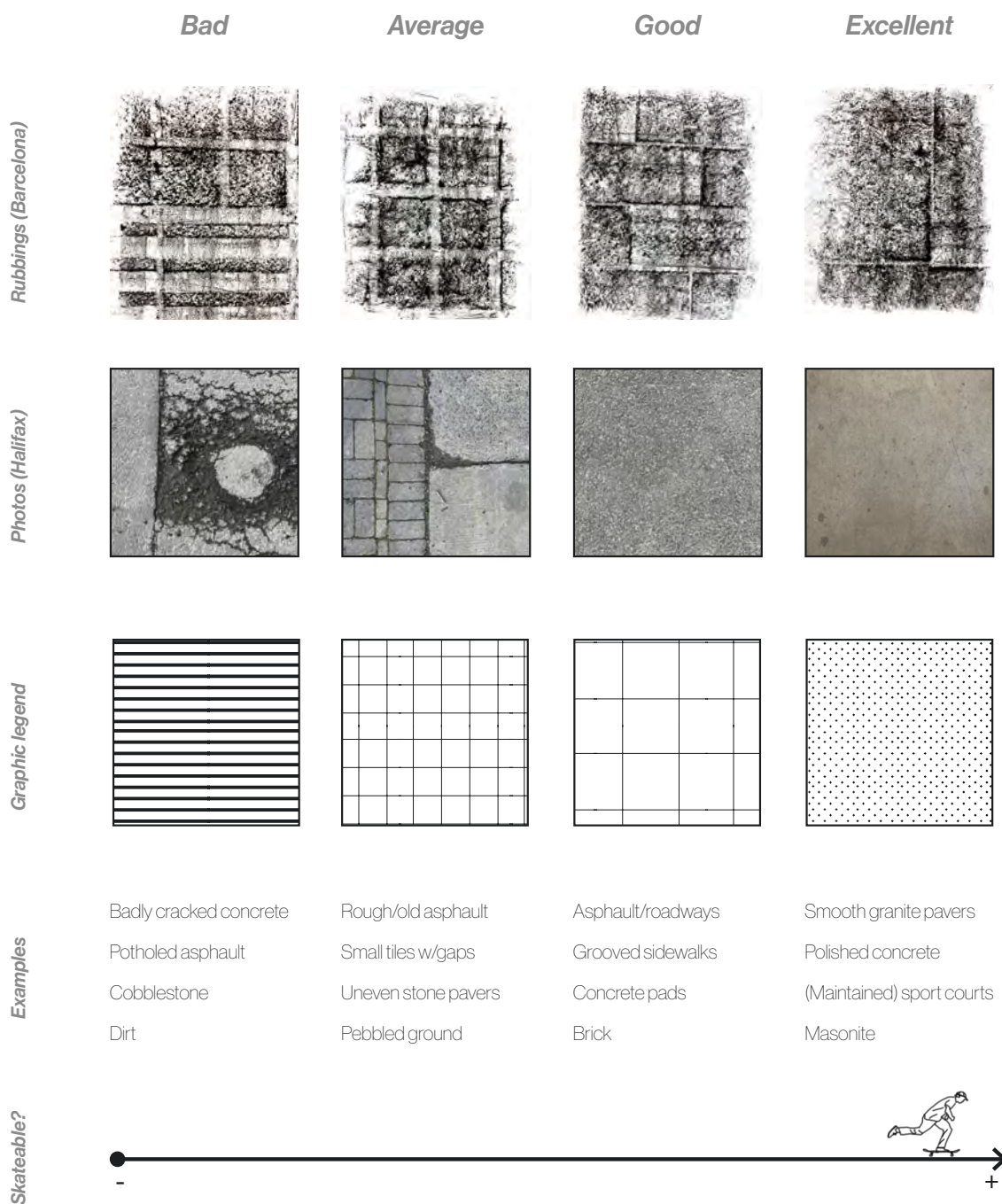

Understanding ground: the surfaces over which a skater rolls have a major impact on the enjoyment, effort, and ultimately distance over which a skater chooses to travel.

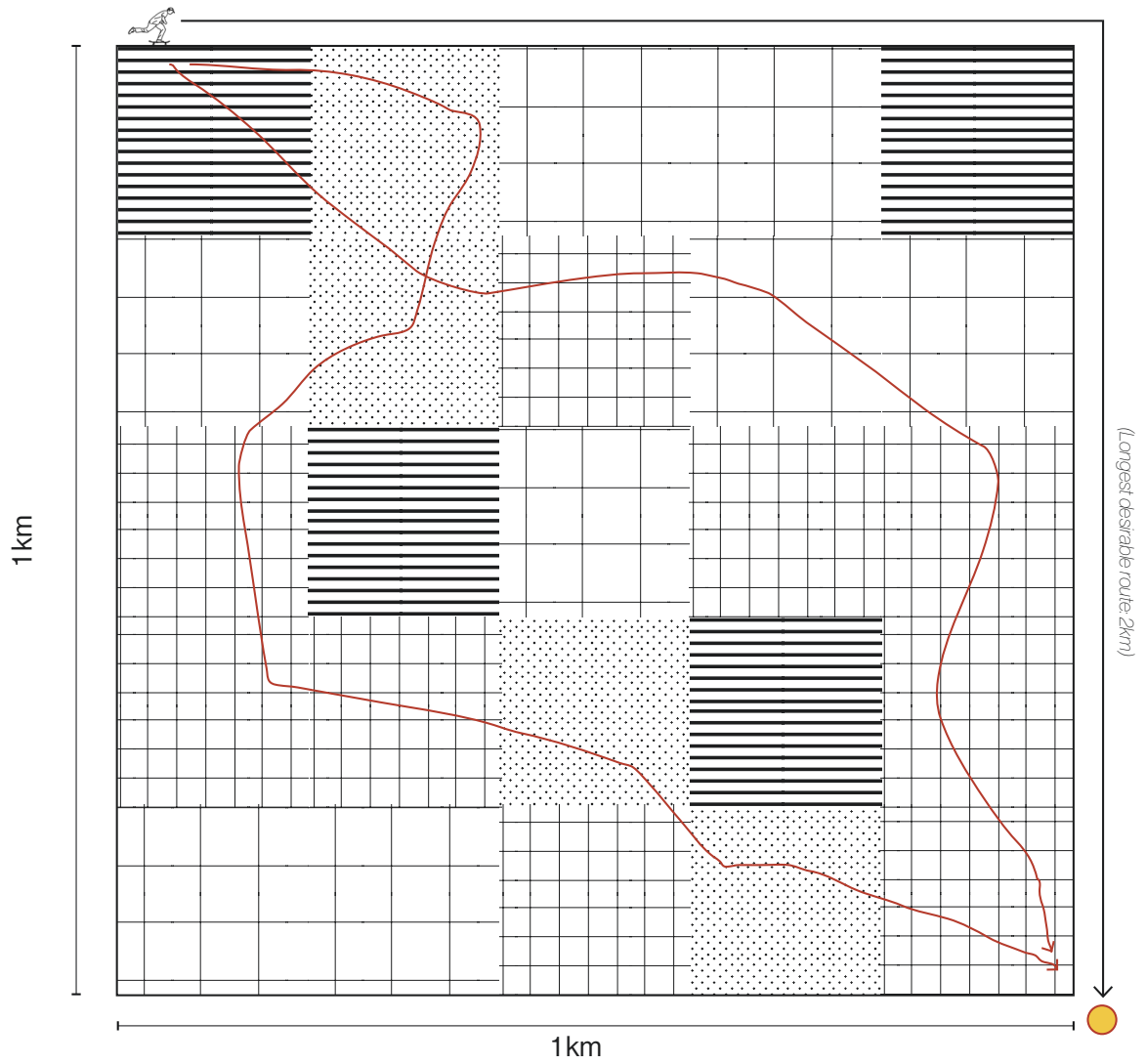

***Ideal skateable distance on variable terrain: < 2km***

Halifax, Nova Scotia is an urban environment with a variety of ground classifications; this means that most trips made on skateboards are limited to less than 2km.

The nine interventions I propose vary in scale between micro-scale “skate-dots” of less than 150m sq., small-scale “spots” between 150 and 600 m sq for up to 10 simultaneous skaters, and a central network-hub that includes a large skateable landscape park and an adjacent building (developed in Chapter 8). Site 6 on the urban map is placed adjacent to a major transit hub that links peninsular Halifax to the wider HRM, and hence is shown as having the potential for another network hub within the strategy - but its development is outside the scope of this thesis.

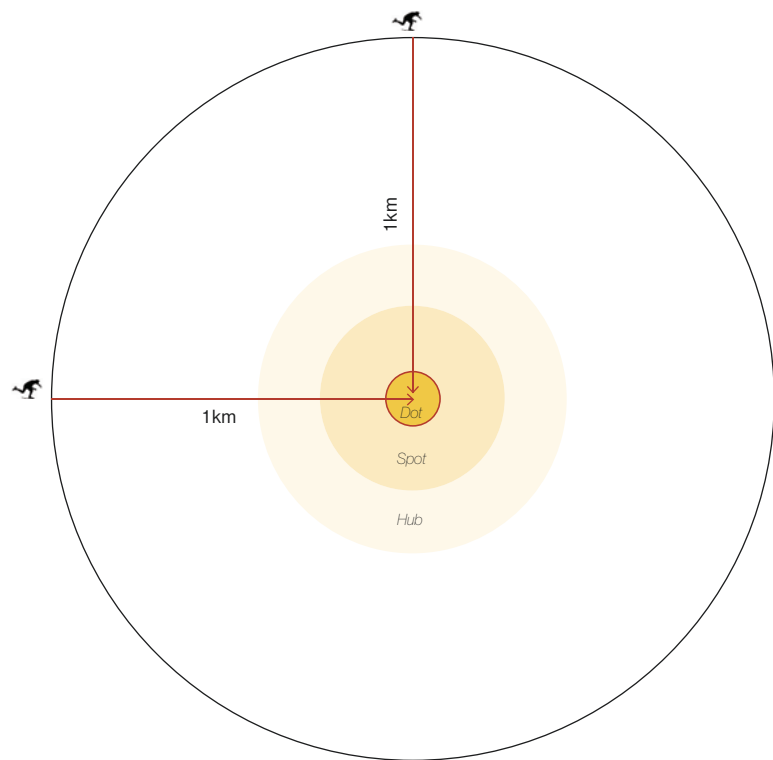

Dots, spots, and hubs form the the urban strategy: three scales of intervention within skateable distance of each other across peninsular Halifax.



### Peninsular Halifax: Existing Amenities

★ Existing Skateboard Amenity

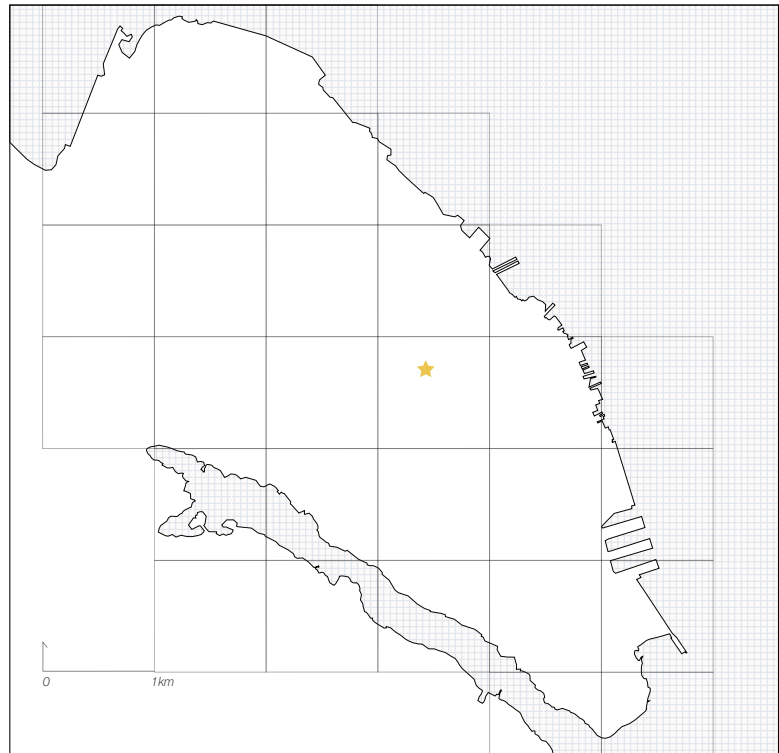

### Urban Growth: HRM Center Plan





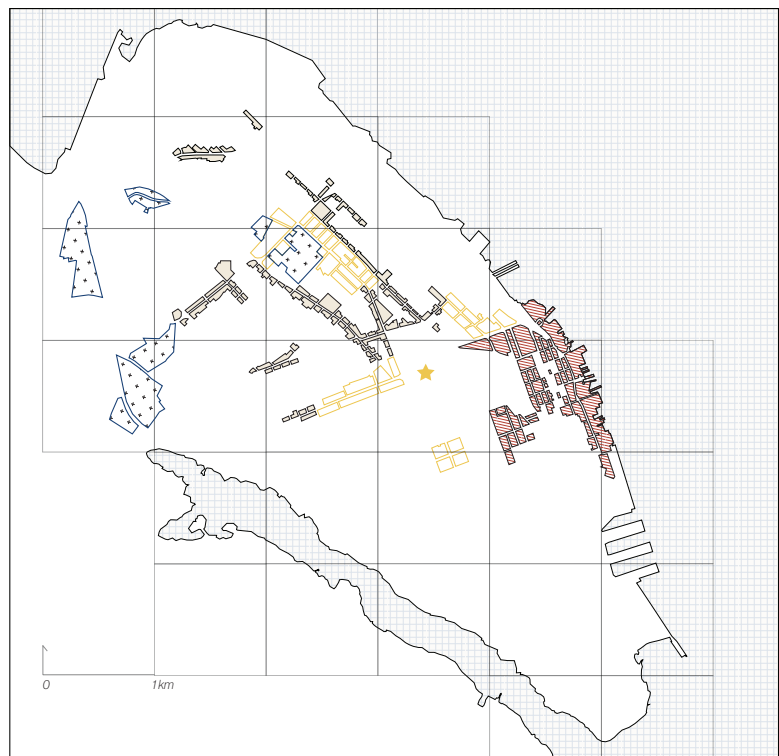

▨ Downtown Designation  
▨ Centre Designation  
▨ Corridor Designation  
▨ Future Growth Designation

★ Existing Skateboard Amenity







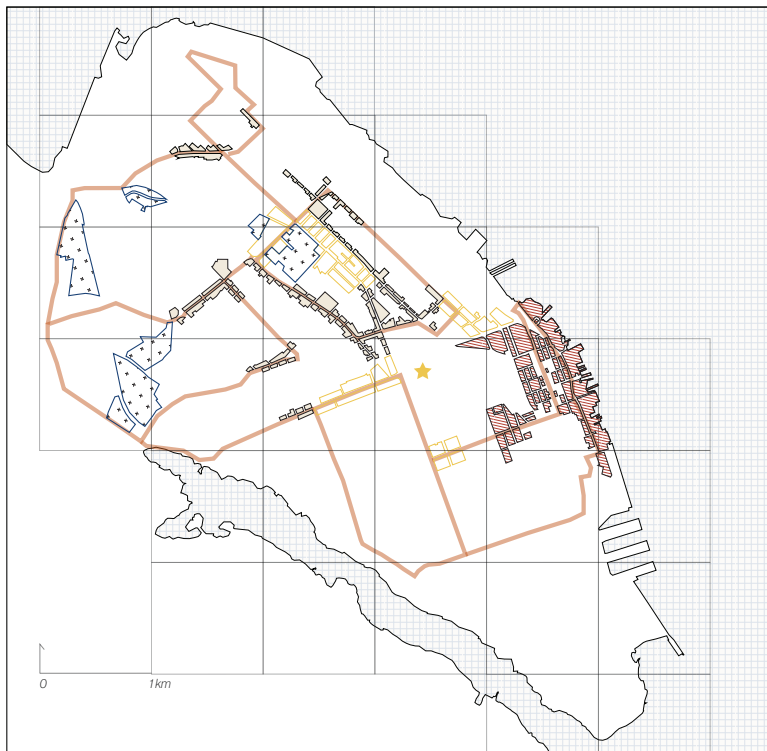

Data from (HRM 2021a; HRM 2021b; HRM 2022)

### Urban Strategy: Major Transit Loops

-  Downtown Designation
-  Centre Designation
-  Corridor Designation
-  Future Growth Designation
-  Major Transit Route
-  Existing Skateboard Amenity



### Urban Strategy: Active Transit Networks



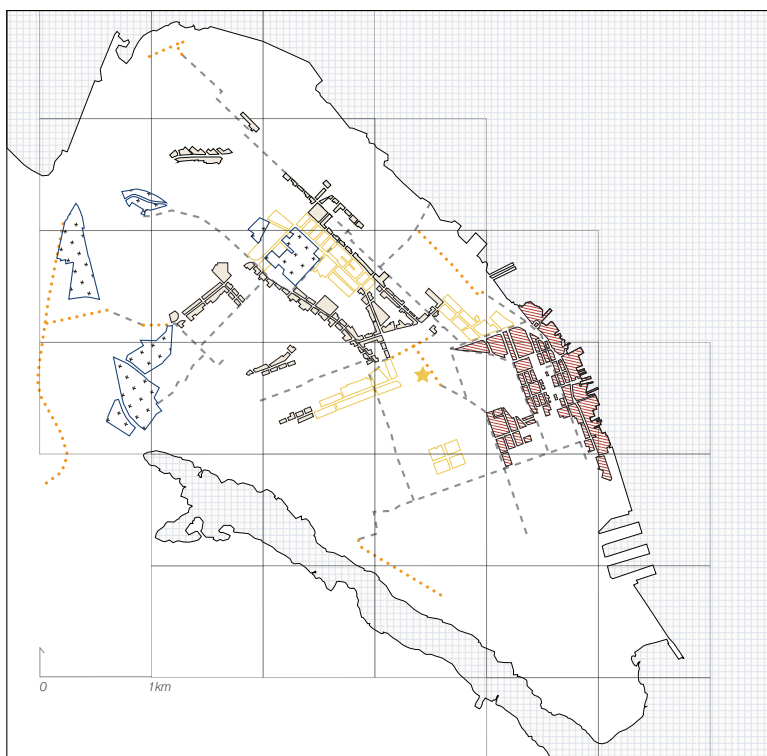





-  Downtown Designation
-  Centre Designation
-  Corridor Designation
-  Future Growth Designation
-  HRM Bicycle Path Network (proposed 2022)
-  HRM Multi-use Path Network (proposed 2022)
-  Existing Skateboard Amenity



Data from (HRM 2021a; HRM 2021b; HRM 2022)

### Urban Strategy:





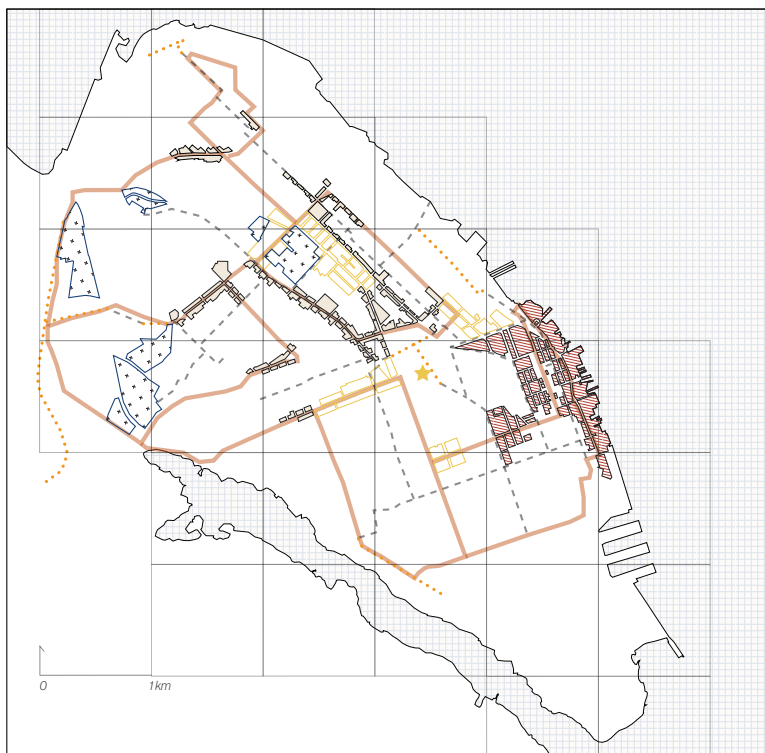

## Transit Network (Composite)

-  Downtown Designation
-  Centre Designation
-  Corridor Designation
-  Future Growth Designation
-  Major Transit Route
-  HRM Bicycle Path Network (proposed 2022)
-  HRM Multi-use Path Network (proposed 2022)
-  Existing Skateboard Amenity



### Urban Strategy:

## Radial Connection

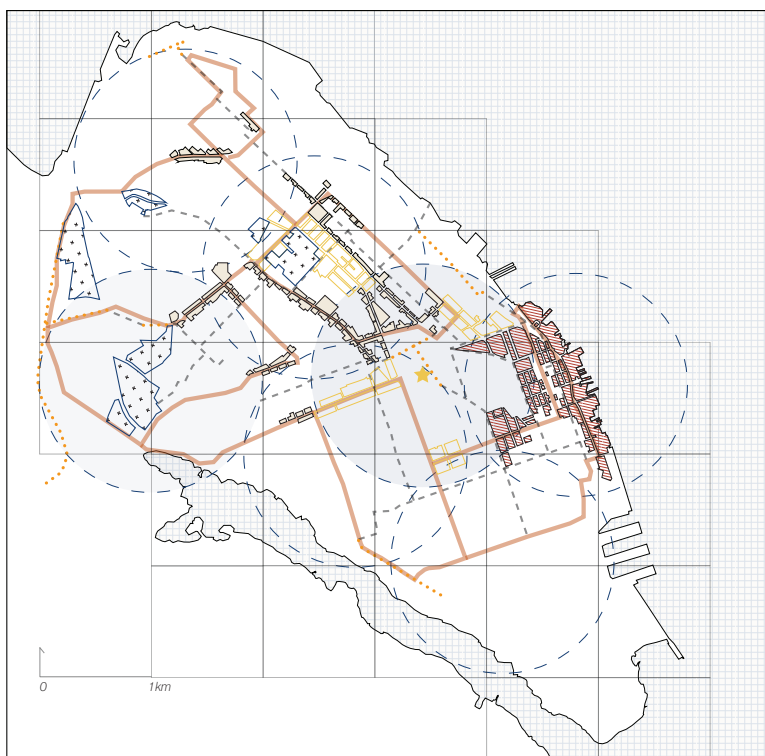

-  Downtown Designation
-  Centre Designation
-  Corridor Designation
-  Future Growth Designation
-  Major Transit Route
-  HRM Bicycle Path Network (proposed 2022)
-  HRM Multi-use Path Network (proposed 2022)
-  Existing Skateboard Amenity
-  Proposed Hub Catchment (r=1km)
-  Proposed Spot Catchment (r=1km)



Data from (HRM 2021a; HRM 2021b; HRM 2022)

### Urban Strategy:

## Parks and Community Facilities

-  Downtown Designation
-  Centre Designation
-  Corridor Designation
-  Future Growth Designation
-  Park and Community Facility Designation
-  Major Transit Route
-  HRM Bicycle Path Network (proposed 2022)
-  HRM Multi-use Path Network (proposed 2022)
-  Existing Skateboard Amenity
-  Proposed Hub Catchment (r=1km)
-  Proposed Spot Catchment (r=1km)

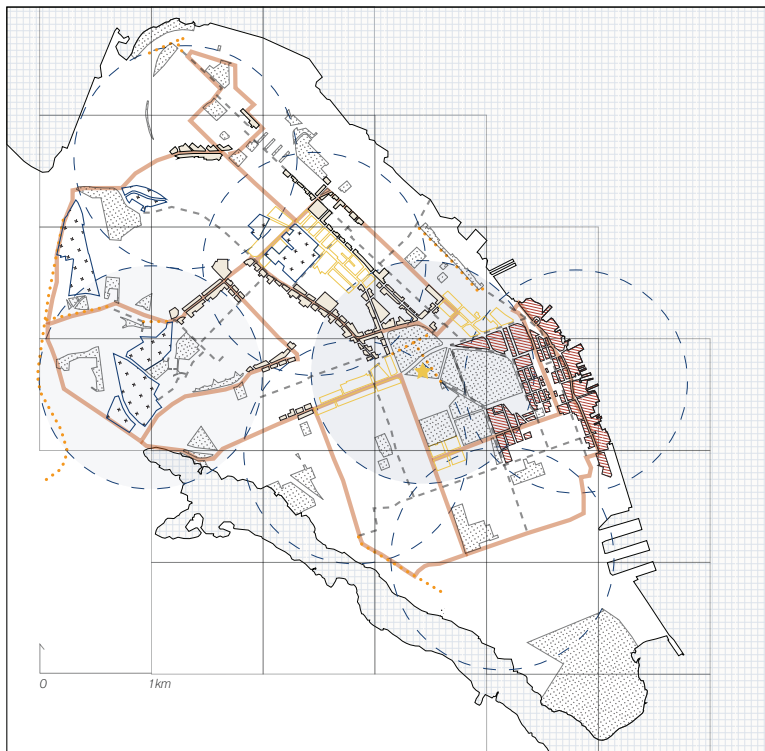

### Urban Strategy:

## Sites of Intervention

-  Downtown Designation
-  Centre Designation
-  Corridor Designation
-  Future Growth Designation
-  Park and Community Facility Designation
-  Major Transit Route
-  HRM Bicycle Path Network (proposed 2022)
-  HRM Multi-use Path Network (proposed 2022)
-  Existing Skateboard Amenity
-  Proposed Skateboard Amenity site
-  Proposed Hub Amenity Site (replacement for existing)
-  Proposed Hub Catchment (r=1km)
-  Proposed Spot Catchment (r=1km)

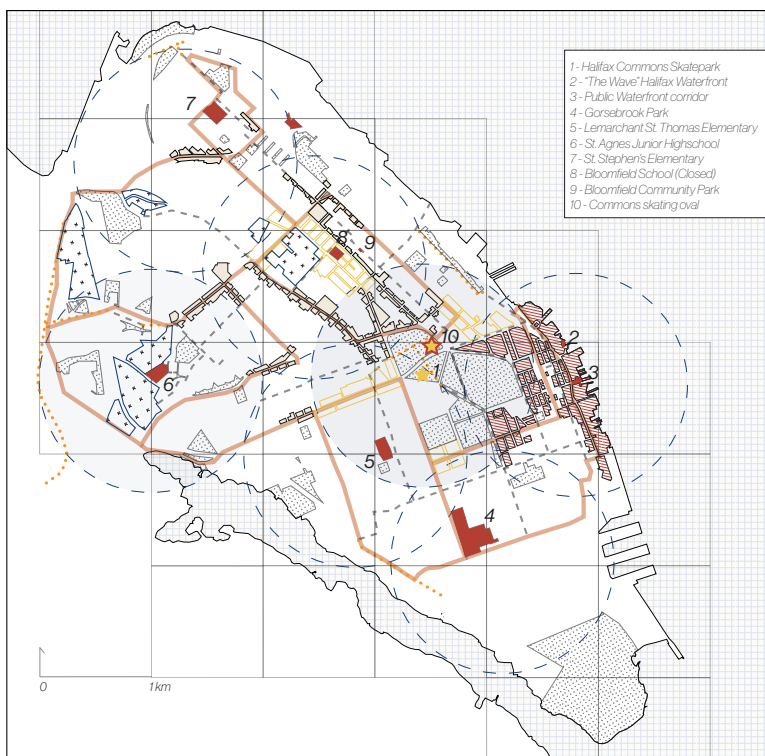

Data from (HRM 2021a; HRM 2021b; HRM 2022)

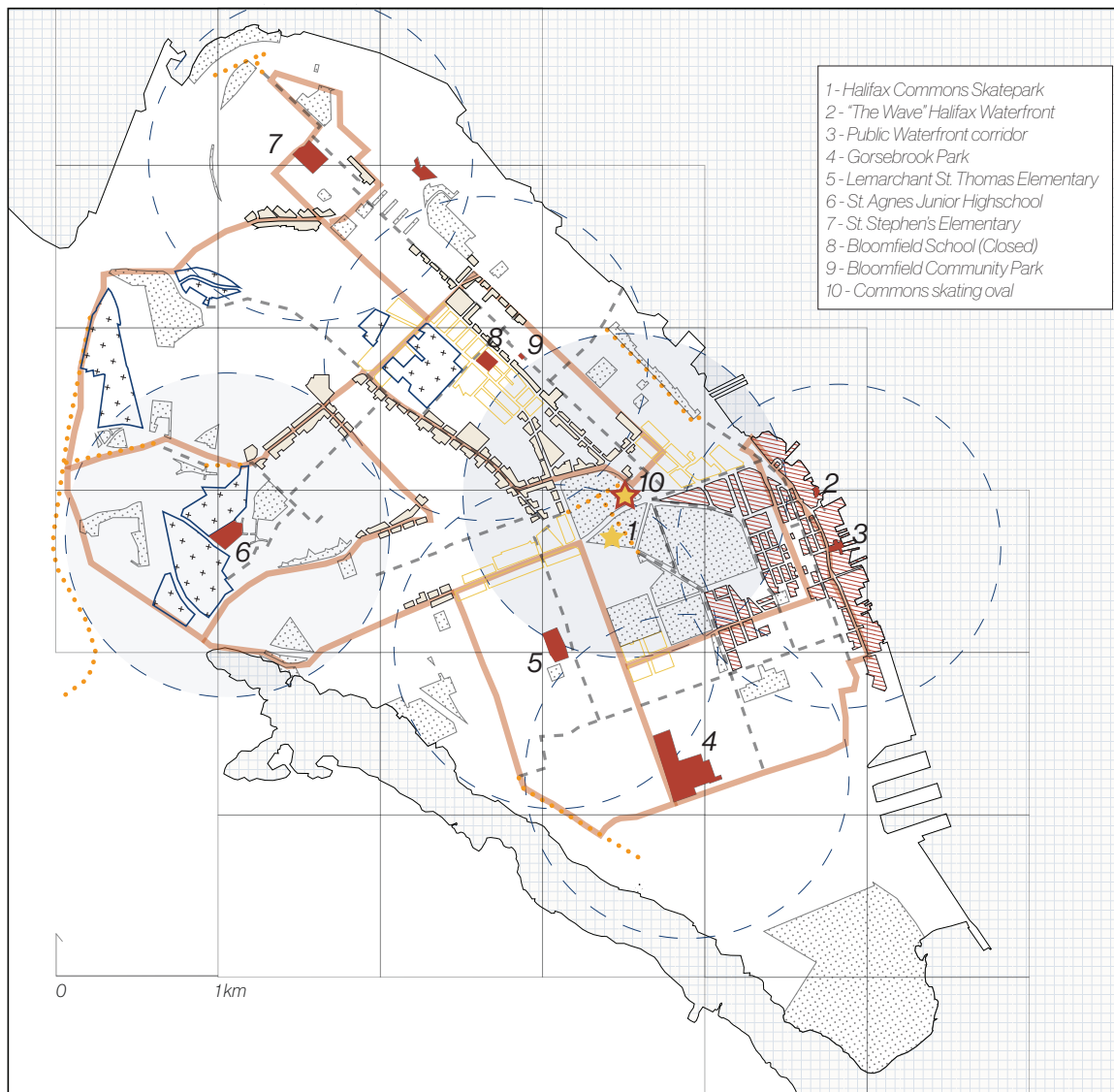

- ★ Existing Skateboard Amenity
- Proposed Skateboard Amenity site
- ★ Proposed Hub Amenity Site (replacement for existing)
- (---) Proposed Hub Catchment (r=1 km)
- (---) Proposed Spot Catchment (r=1 km)
- ▨ Downtown Designation
- Centre Designation
- ▤ Corridor Designation
- + Future Growth Designation
- ▤ Park and Community Facility Designation
- Major Transit Route
- - HRM Bicycle Path Network (proposed 2022)
- ... HRM Multi-use Path Network (proposed 2022)

Urban strategy for a skateable Halifax (Data from HRM 2021a; HRM 2021b; HRM 2022).

**Skate Dot**

< 150 m<sup>2</sup>  
1-4 people

*Project name: Wavewalk*  
*Designer: Adam Kuby*  
*Location: Portland, OR*

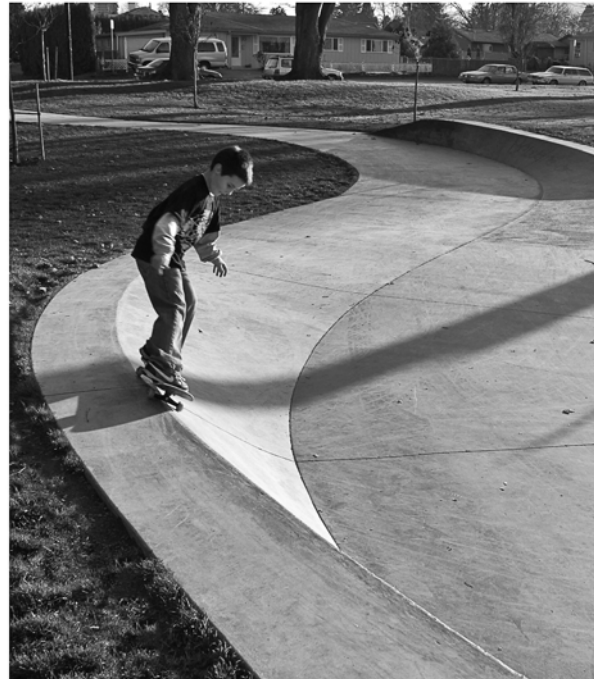

Vocabulary: Skate Dot. Images of Adam Kuby's Wavewalk. (Kuby 2006)



### Skate Spot

150 - 600m<sup>2</sup>  
4-10 people

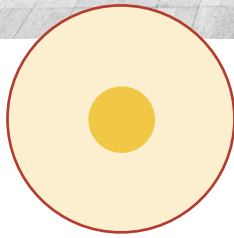

*Project name:* Barcelona Born Skateplaza  
*Designer:* Skate Architects  
*Location:* Barcelona, ESP



Vocabulary: Skate Spot. Images of Born Skateplaza. (Hevia 2020)

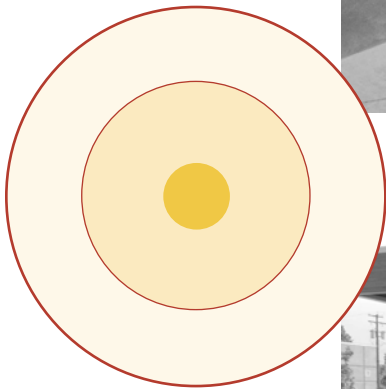

**Network Hub**

> 600m<sup>2</sup>  
10+ people



*Project name:* Chuck Bailey Youth Park  
*Designer:* Newline Skateparks  
*Location:* Surrey, BC

Vocabulary: Network Hub. Images of Chuck Bailey Youth Park. (Newline Skateparks 2023)



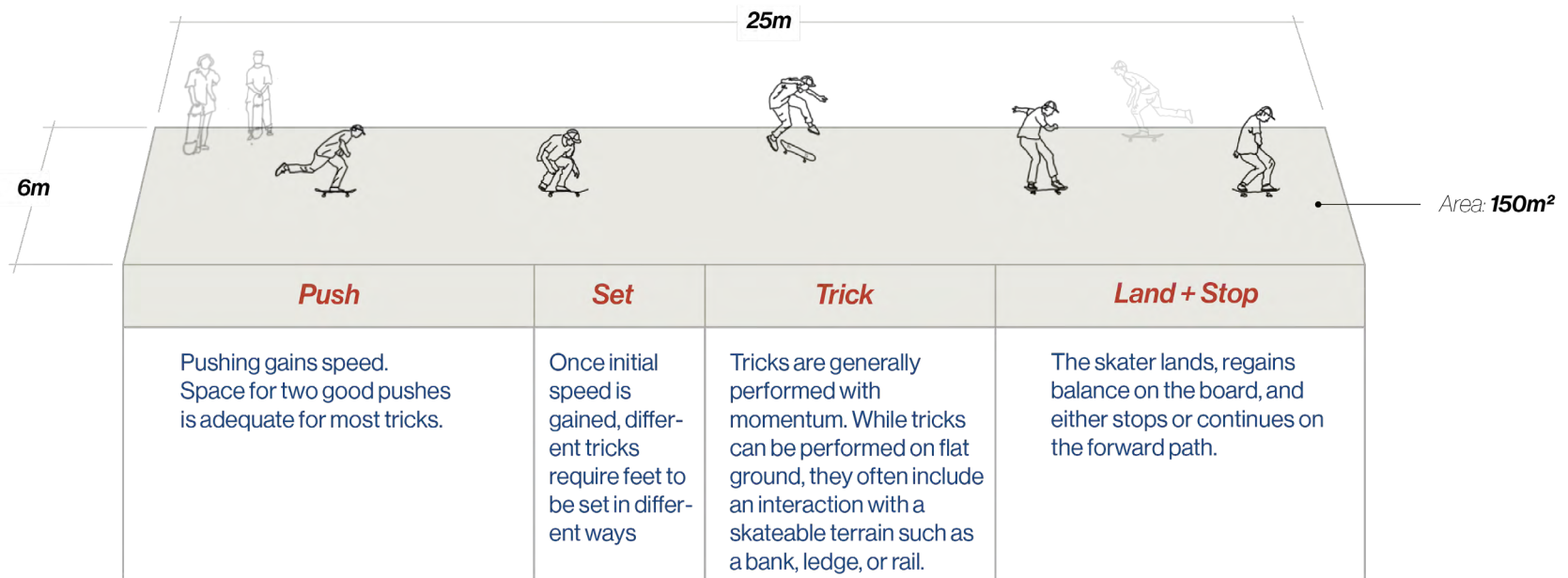

Design Notes: Spatial minimums. Image shows 25m as the minimum run of space required for the execution of a skateboard trick. (VDZ+A 2022)

## Landscape As Flow: St. Stephen's Elementary



The site at St. Stephen's: a naturalized corner park.

The site at St. Stephen's is a naturalized street corner in a residential neighbourhood. With a gradual 1.5m elevation change from the level of the school down to the road, the design intervention is about layering place - specifically landscape - with function. Creating horizontal flows along the contours of the site allow the feel of the space to be maintained, creating a space that is part functional, part aesthetic.

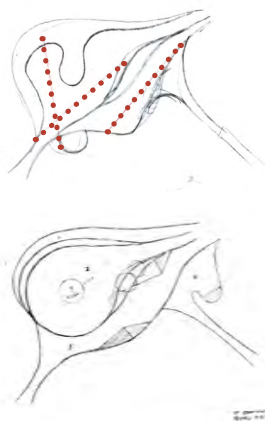

Red dotted lines indicate 25m runs.

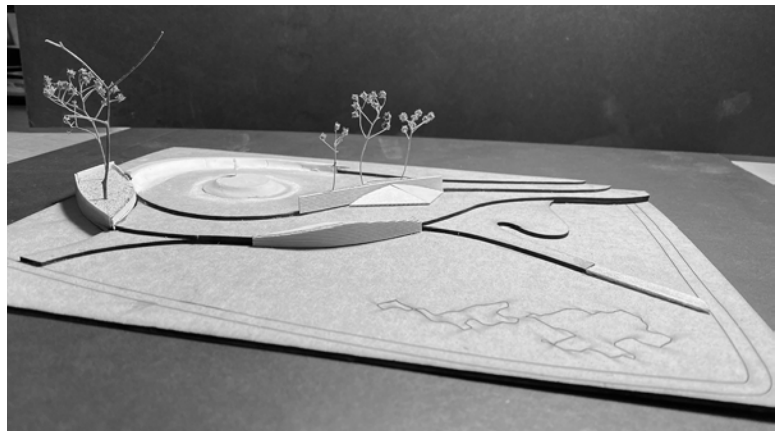

Layering landscape and function: a schematic model study of existing contours as lines of movement.

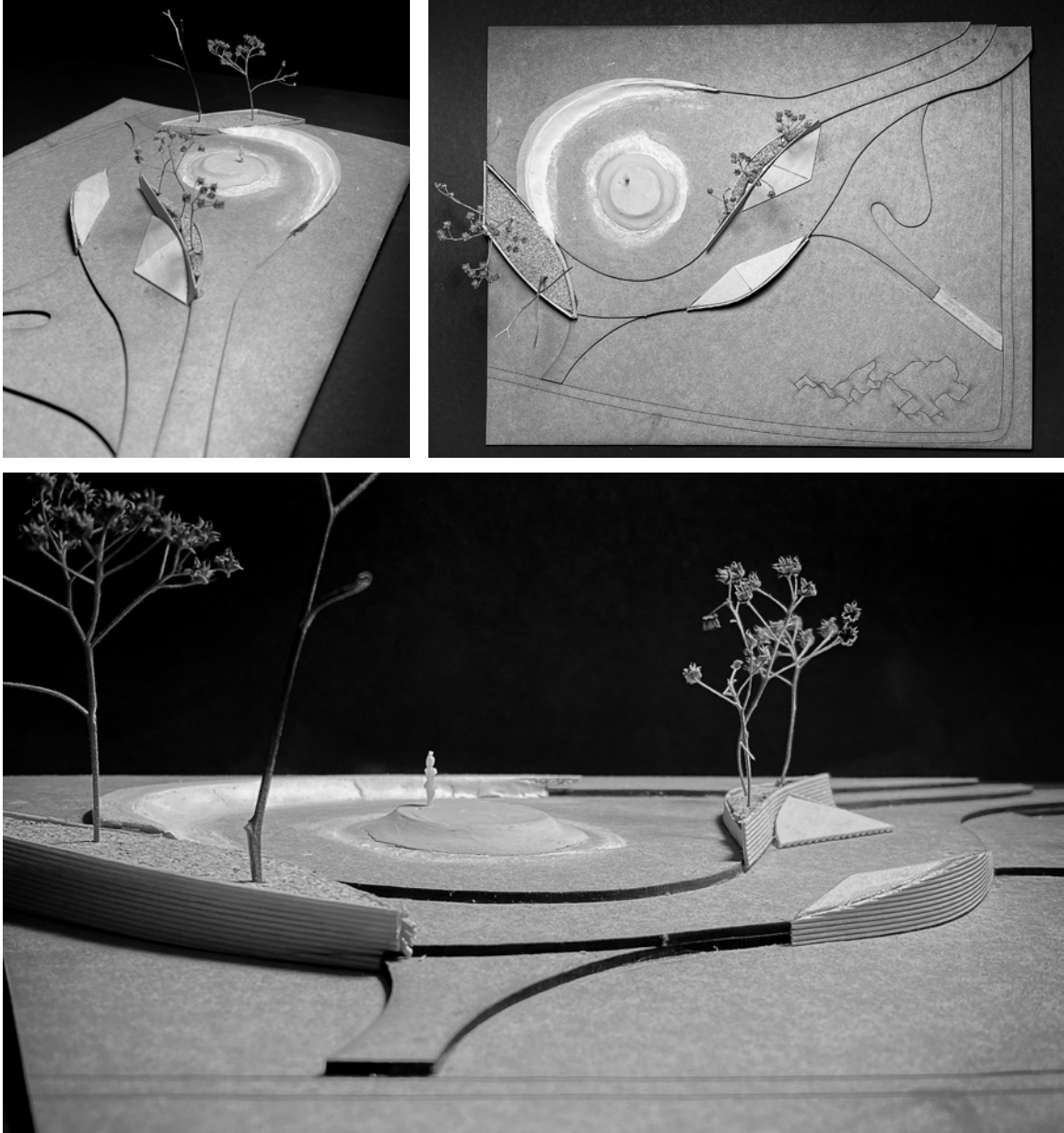

Simple concrete quarter pipes and terraces follow curved contours to create spaces of interaction - be that on a skateboard, or as a type of informal stage and amphitheatre. On the middle bench, a run of concrete hipped banks create skateable delights below a landscaped planterbox.

## Enhancing the Existing: Le Marchant St. Thomas School



Le Marchant St. Thomas Elementary: the parking lot - while unremarkable to the uninterested eye - is subtly perfect for skateboarding.

In 2019, construction was completed on the new Le Marchant St. Thomas Elementary School in Halifax's South End. While the design architects cite maximizing green space for outdoor play and a playful exterior aesthetic of the building that "picks up on the whimsy of children's play" (Architecture49 2023), it is unlikely that their design anticipated skateboarders frequenting the parking space along the northeast side of the school. Yet inadvertently, Architecture49 created a public space that is remarkably ideal for skateboarding.

As with any good skatespot, the reasons why the space works is both subtle and complex. First and foremost, the ground is ideal: a long run of smooth and gently sloping ground flanks the school along its northeastern side. In my experience, the asphalt also seems to dry quickly after rain events. Additionally, the parking lot is a relatively safe place to skate, as car traffic is limited, predictable, and easily seen. Secondly, the spot is well-lit in the evenings - something that the existing Halifax Common skatepark



A skater pops a kickflip on the smooth ground at Le Marchant St. Thomas elementary.

struggles with. But the primary reason is that the sidewalk and its curbs are ideal for a trick called a “slappy grind”. In a slappy, the skateboarder doesn’t ollie the board off the ground, but rather goes weightless for a brief moment as they push the skateboard’s wheels to ride up the side surface of the curb, allowing the trucks to lock into a grind on the curb’s edge. What is interesting about a “slappy curb” (a typology of skateable terrain that these particular curbs fall into) is the broad range of users that they afford themselves to. For beginners who are just learning to ollie (the act of popping the board into the air with the feet staying attached - skateboarding’s most fundamental move), the curbs provide a low-height (and low consequence) place to practice the precision of landing upon and grinding the edge of a ledge. These curbs in particular are good for learning the feeling of a grind, as the sloping wheelchair curb-cuts allow the skater to ride into (rather than pop into) a grind (to grind is to have the metal trucks as the point of contact for forward motion as opposed to the wheels - this means that the object being grinded fits between the wheels of each truck).



A skater performs a “slappy” grind on the waxed curbs at Le Marchant St. Thomas school. Slappy grinds work well on curbs that have a slight angle on the sidewall rather than a 90 degree vertical slope; these curbs are in possess this rare form.

On the opposite end of the spectrum, slappy grinds are popular tricks among older skaters, who know and love the feeling of a grind, but no longer possess the agility to pop into (or are unwilling to take the risk of falling while doing) a grind. With this in mind, the slappy curb is actually one of skateboarding’s most equitable terrains.

Le Marchant St. Thomas is an existing skate spot as it - but the addition of a bank (another one of skateboarding’s most equitable and versatile terrains) would make it fantastic. Hence, this proposed intervention is simple: the addition of a long, low bank.

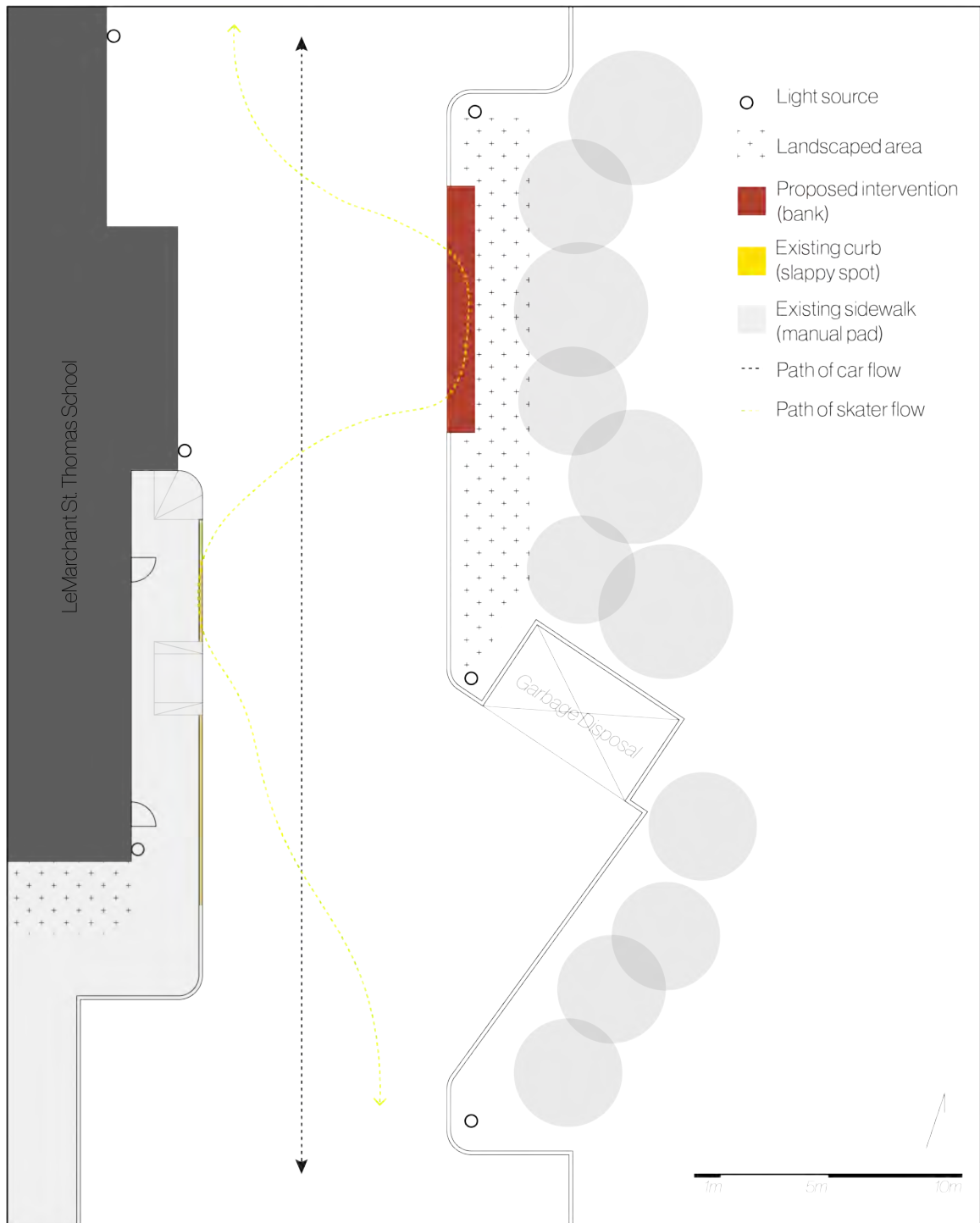

The simple addition of a bank would make Le Marchant St. Thomas elementary an excellent skate spot, by allowing the slappy curbs to be skated in a line - that is, two or more tricks in a row.



Plan view, 1:200 model





North view, 1:200 model



Aerial view, 1:200 model



Aerial view, 1:200 model



Detail, 1:200 model

## Let Them Build: Bloomfield DIY

As outlined in Chapter 4, DIY skate spaces are valuable social hubs within skateboard communities. Located in Halifax's North End, the old tennis courts at the decommissioned Bloomfield School have been transformed by skaters through small-scale constructions of wood, concrete, and brick. At Bloomfield, the existing spot structure is retained: skaters building physical objects with total agency in the process builds physical works, but also provides the social spaces for relationships, empowerment, and accomplishment.



Bloomfield DIY spot is a space created by skaters - a landscape transformed from derelict to productive.

In the case of Bloomfield, which is at best a prominent eyesore and at worst a public hazard (Ryan 2023), there is no doubt that skateboarding breathes new life into the site and regulates it through consistent inhabitation.

Constructions like Bloomfield are adaptable, functional, and pose no cost to the city; simply allowing them to exist at sites trapped in developmental purgatory provide a net positive to the public realm.

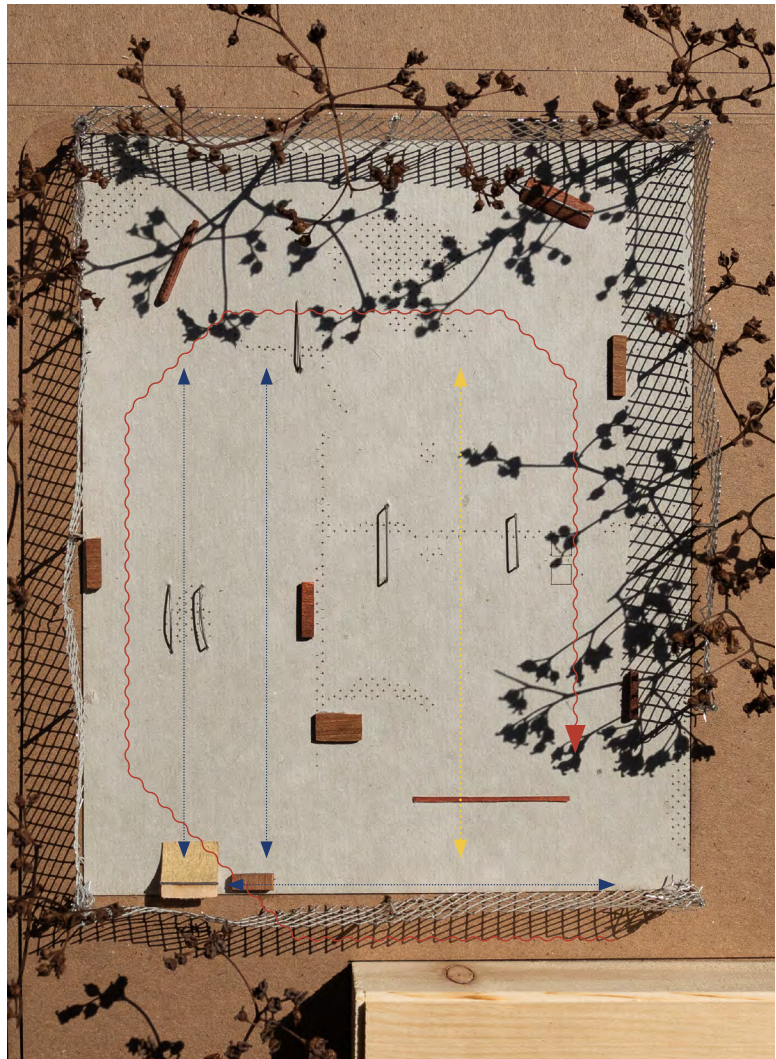

Studying how skaters design space is useful, as the spaces between features become more important than the features themselves. At Bloomfield, skaters work around rough ground to create patterns of linear flow within an overarching circular flow. We can learn from these spaces: when designing for skateboarding, cross-flow (which causes collisions) is to be avoided.



Bloomfield DIY Spot, 1:200 model



Bloomfield sits on the corner of a busy street; the fenced in area of the tennis courts provides a natural boundary to the space.



The features of a DIY skate space are constantly changing and evolving - new constructions replace old ones that either become boring, or become worn down with use.



The adaptability of the space provides opportunity for people to learn skills on as well as off the skateboard, as it affords users the chance to easily partake in or observe new constructions.



## Objects of Agency: A Kit of Parts for Assembly and Reassembly

Building on the idea of a DIY skatespace where users interact with and transform their physical environments, the final intervention explored for the urban strategy is a kit of parts that can be deployed within the city, and serve multiple layers of function: as sculpture, as functional furniture, and as skateable terrain.

The exploration centers around creating objects that are able to be adapted and moved by a user (or users). The goal is to facilitate the autonomous creation of skateable terrain that can be moved around the city periodically or remain stationary, providing auxiliary function to an existing space such as a basketball court or outdoor hockey box.

These pieces were created as prototypes for the work in Chapter 7.

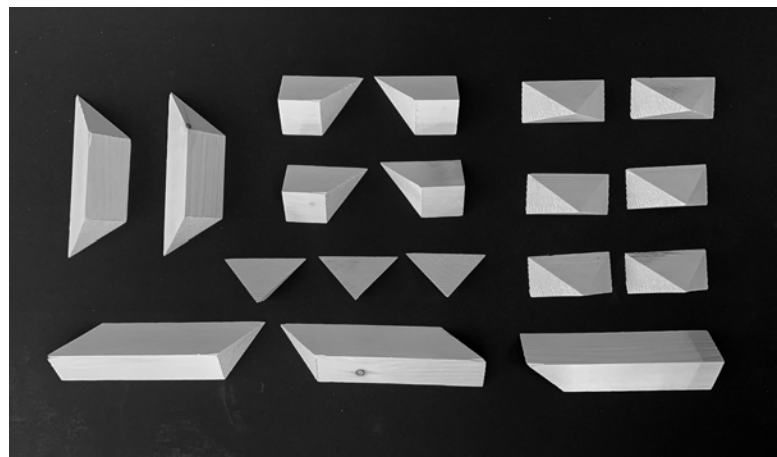

Kit of parts: a series of blocks made with 45 degree cuts was designed to test a model of user agency in the design/assembly process. Each of the pieces can stand alone as an object, or be combined by users in some arrangement to create an undefined sculpture, bench, or skateable terrain.

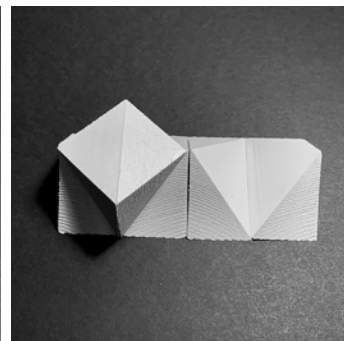
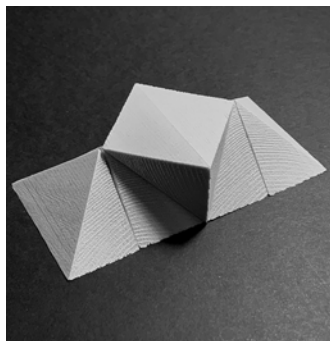
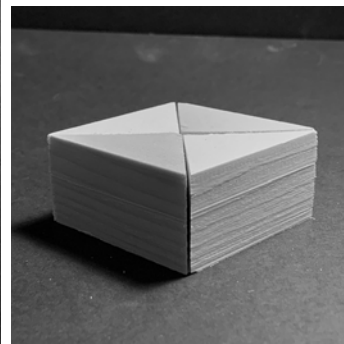
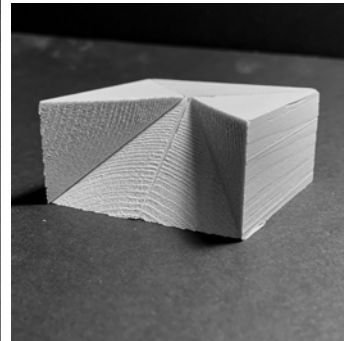
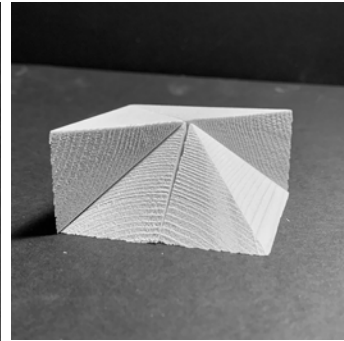
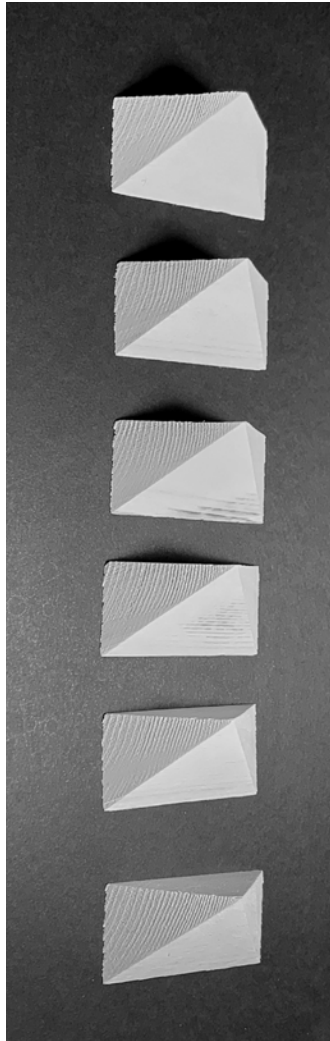
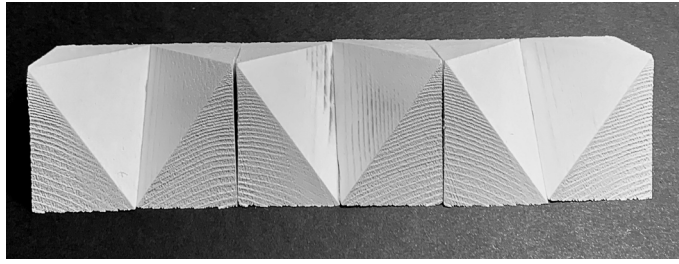

Kit of parts: various arrangements of a repeated form.

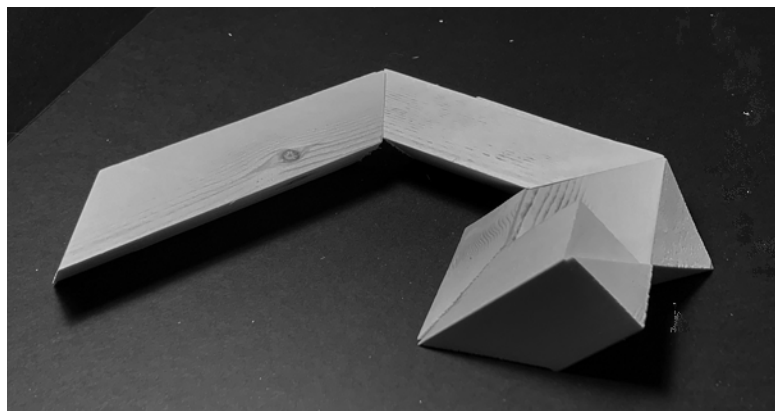
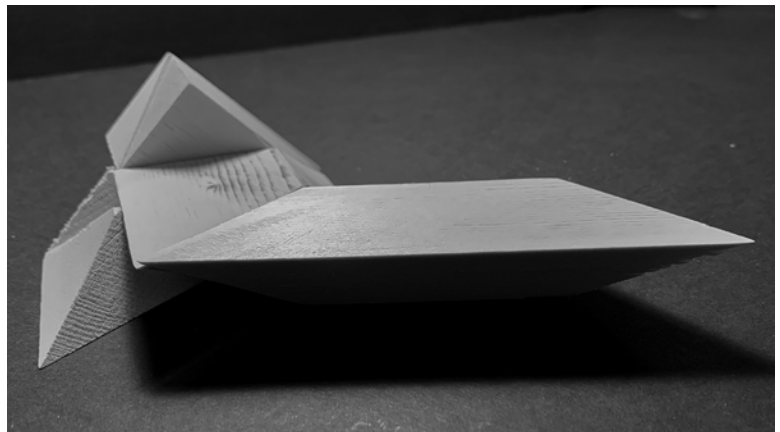
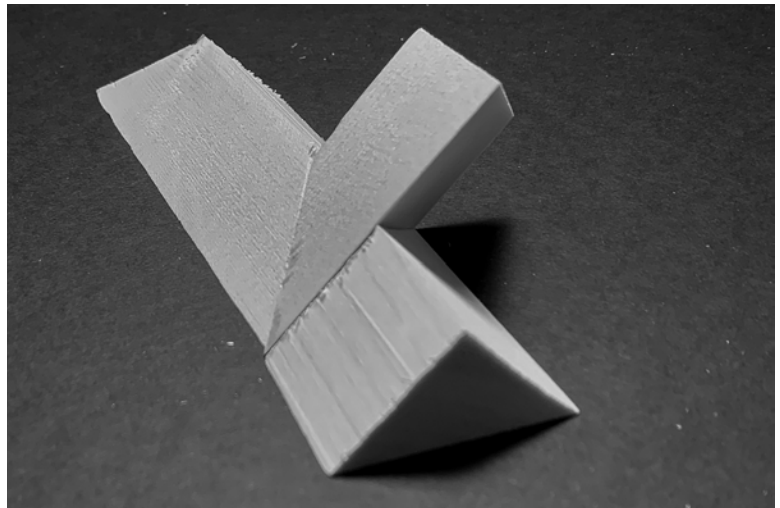
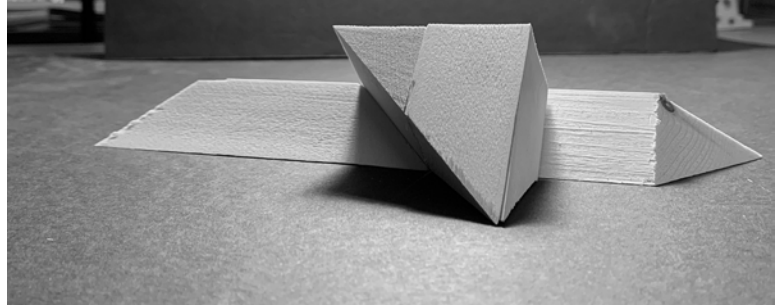

Kit of parts: explorations focussed around sculpture and seating.

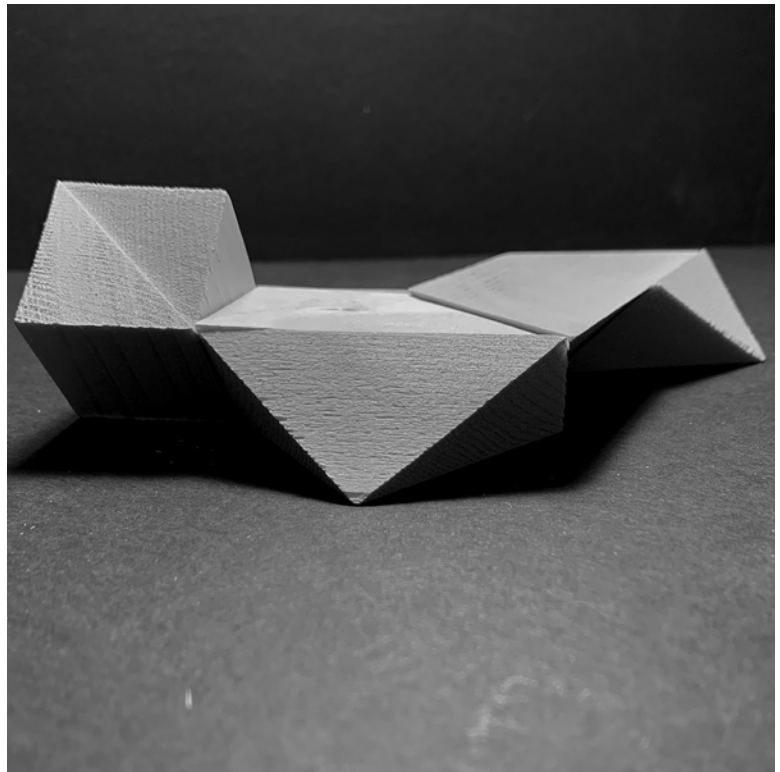
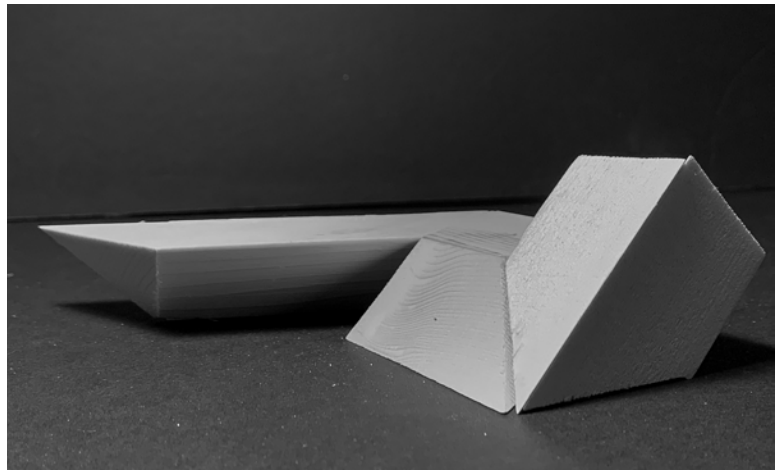
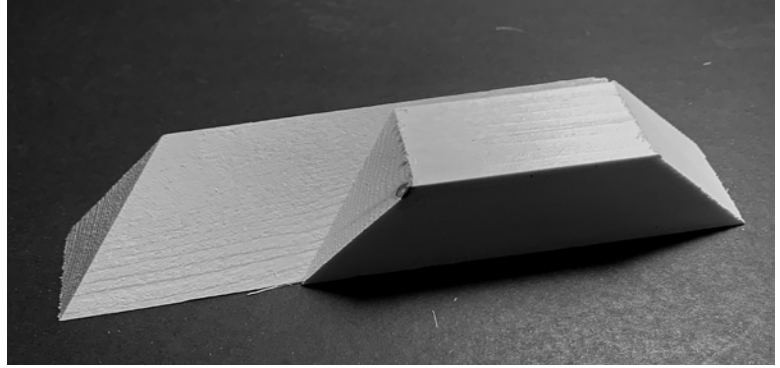

Kit of parts: explorations focussed around sculpture and seating.



Kit of parts: refining and reducing.



Kit of parts: as sculpture and terrain.



Kit of parts: as sculpture and terrain.

## Chapter 6: Riding Modern Art: Designing Between Space, Form, and Movement



A skater drops in on *La Ola* by Jorge Oteiza (1998) outside of MACBA, Barcelona (Schaeffer 2022).

Designing for skateboarding is an interesting and stimulating process. The forms and geometries that generate ideal skateable terrain are fundamentally sculptural; yet they sculpt space and movement as much as they shape physical form. The lens that a skateboarder uses to analyze and identify possibility within form is a dimension of potential that is infinite and wholly unique; somewhere between unlimited imagination and individual limits of movement and skill exists a median, which becomes an embodied act of performative expression.

I challenged myself to design through this lens, not limiting myself to what something was, but instead embracing and seeking out its potential. Throughout this process, I've been



continually drawn to modern art and sculpture, particularly minimalism. Many of the forms I was developing looked in plan or in section like modern art; and they were the result of relationships of movement, flow, and material. I came upon the work of Raphael Zarka, an artist, sculptor, and skateboarder, who says

minimalism comes from the geometrical side of abstract art. Normal artists want to create a form, a composition, but instead of having figures, trees or flowers, you have triangles, circles and cubes. The most radical artists from minimalism, those that I refer to as “phenomenological minimalists”, don’t really care about objects. They care about space. They don’t really care about vision, they care about experience. It’s not about putting an object in a space and looking at it, they think that objects redefine the whole space. So the artwork is the relationship between a simple form and the space around it. For them, a sculpture is not an object, it is a space that you don’t only look at but that you experience through motion, with your whole body and not only your eyes. I think that is very important and suitable to the logic of skateboarding. (Schwinghammer 2015)

With this lens, I began to look at artwork as terrain, reinterpreting the spaces produced in artwork as skateable objects.



Raphael Zarka's work combines form and movement into experience; objects of art are also objects of play. Here, a skater wallies over one of Zarka's pieces in *Paving Space*, on display in Paris, 2016 (Verret and Zarka 2016).

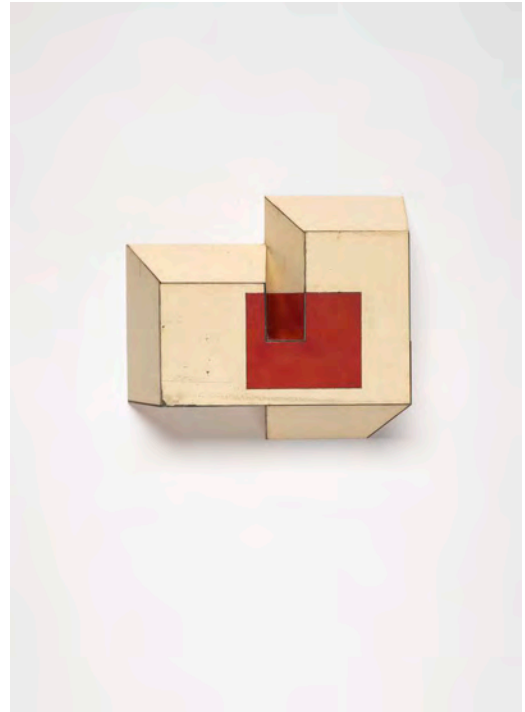

Ted Larsen's sculptures have nothing to do with skateboarding; yet their forms lend themselves to kinetic movement on a skateboard. Skateboarding becomes a new lens through which to experience art and space (Larsen 2023)



Zulmiro do Carvalho, *Curvatura*, 1971. Carvalho designed many sculptures - both for galleries and outdoor public spaces - with sweeping curves and qualities of movement that anyone who has experienced movement on a skateboard can't ignore - even if not easily skateable. (Arteinformado 2017)



Kazimir Malevich, *Suprematism*, 1915. When interpreted through a lens of potential skateable terrain, *Suprematism* begins to represent abstractions of features and movement; it could easily be a plan drawing of ledges of varying heights with vectors of movement overlaid to a skater (FAA 2019)

The design proposed in Chapter 8 evolved from kinetic interpretations of masses, forms, and volumes. Using geometric minimalism as a driver, a playful process of considered form-making began to set spatial relationships aesthetically, before revising them to meet functional goals.

The following images relate moments within that process.

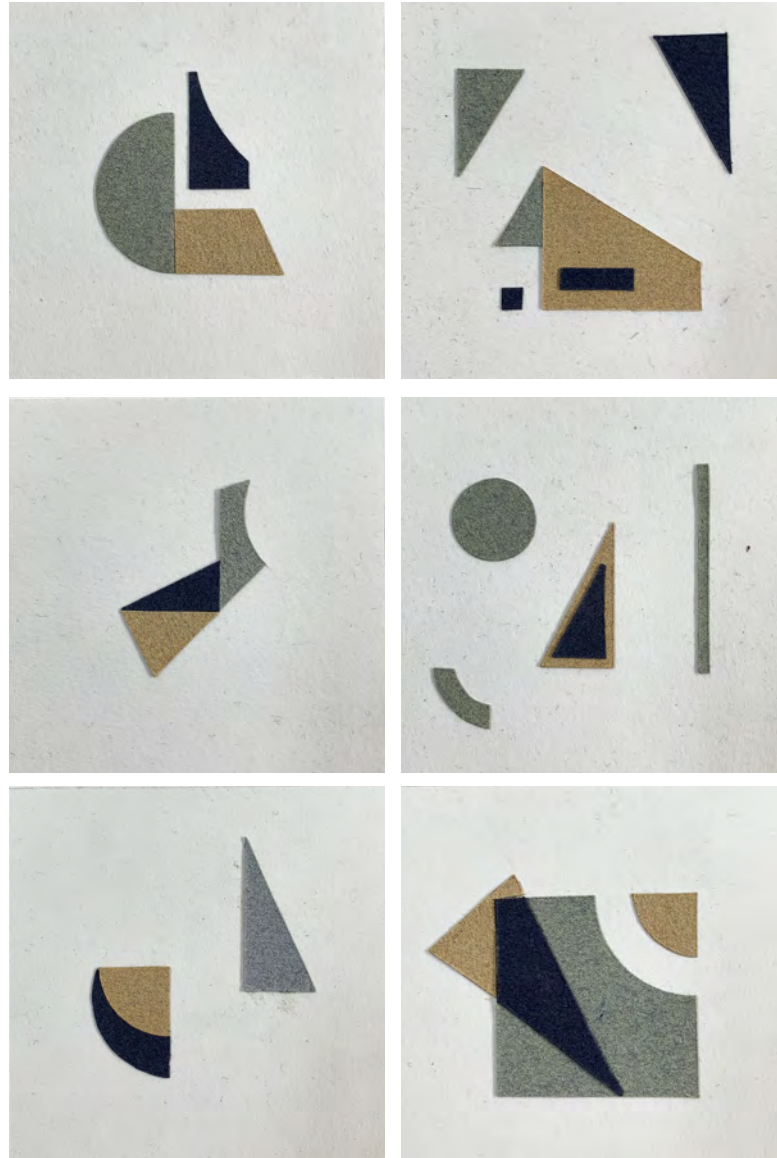

Collages of form and movement: a process of schematic design for skateable spaces. The images to the right were created as plan drawings of skateable spaces, the scale of which is left open to interpretation.

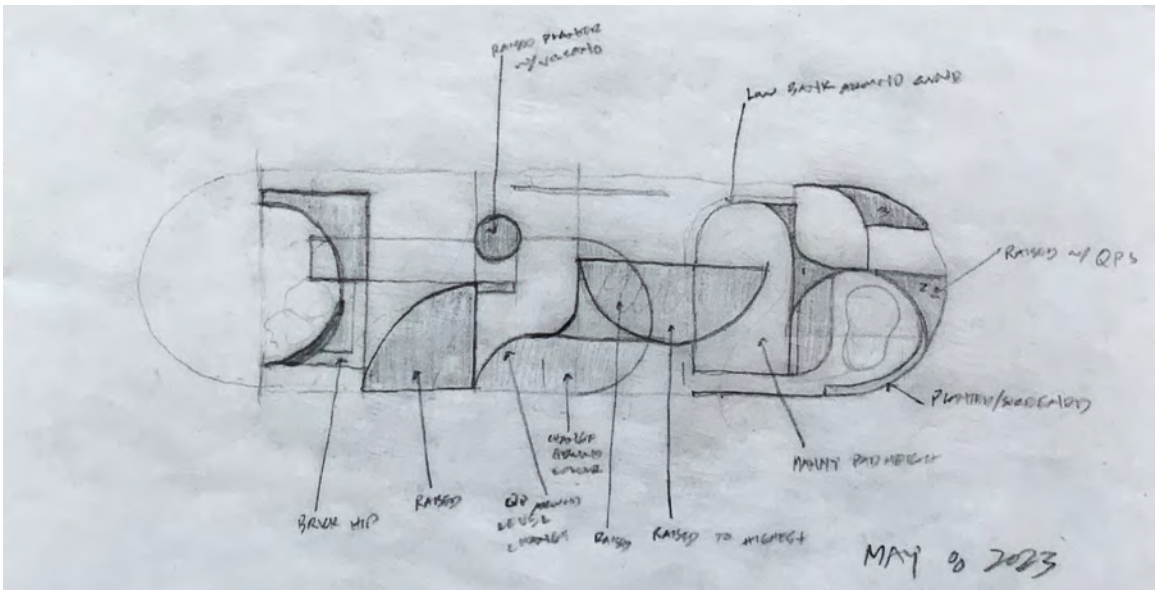
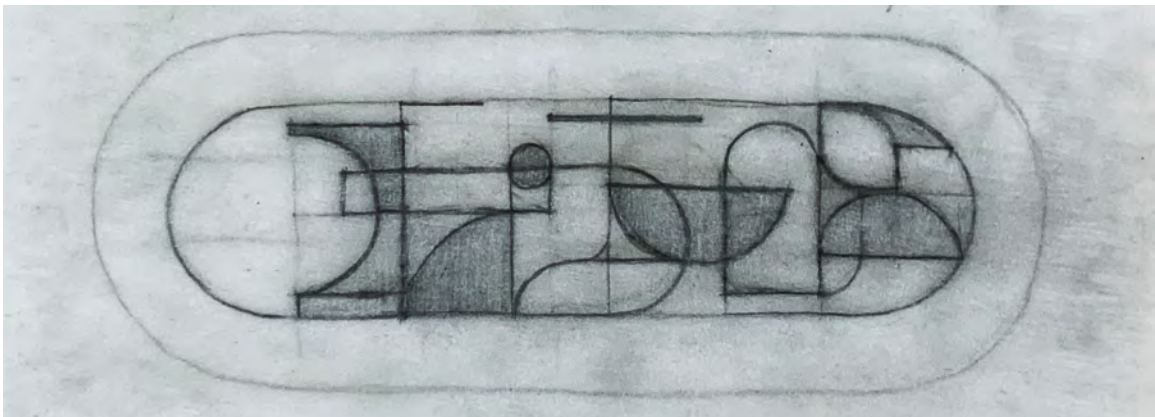
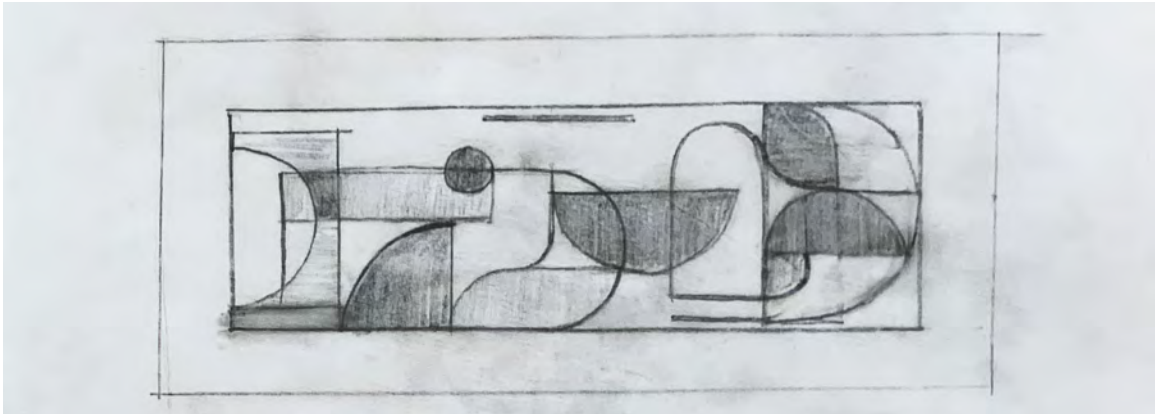

Layers of process: an artwork becomes a schematic landscape.



Layers of process: an artwork becomes a schematic landscape.



Layering form and function: an artwork becomes a schematic plan for a building.

## Chapter 7: Modular Objects of Skateable Desire

This chapter combines the process of designing with the act of doing through the construction of a sculptural bench furniture. While the bench is at its most basic level functional, a correct configuration is undefined, and its pieces deconstruct into fragments of skateable terrain. The design was built at full scale and then tested by a group of skaters, who continually assembled and disassembled the features into new configurations, unlocking unique potentials each time. In this way, the bench design is programatically layered; functionality, sculpture, performance, and social connectivity all intermingle through its use. These are the same drivers for the final design proposal.

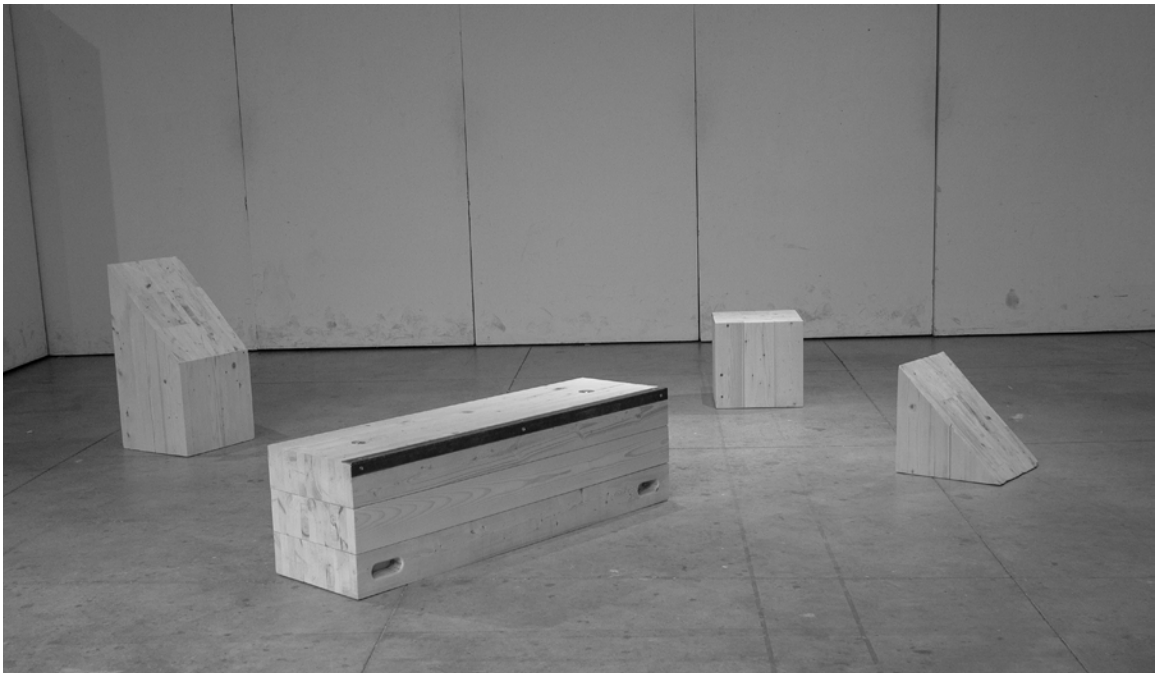

Four primary pieces make up the kit of parts.



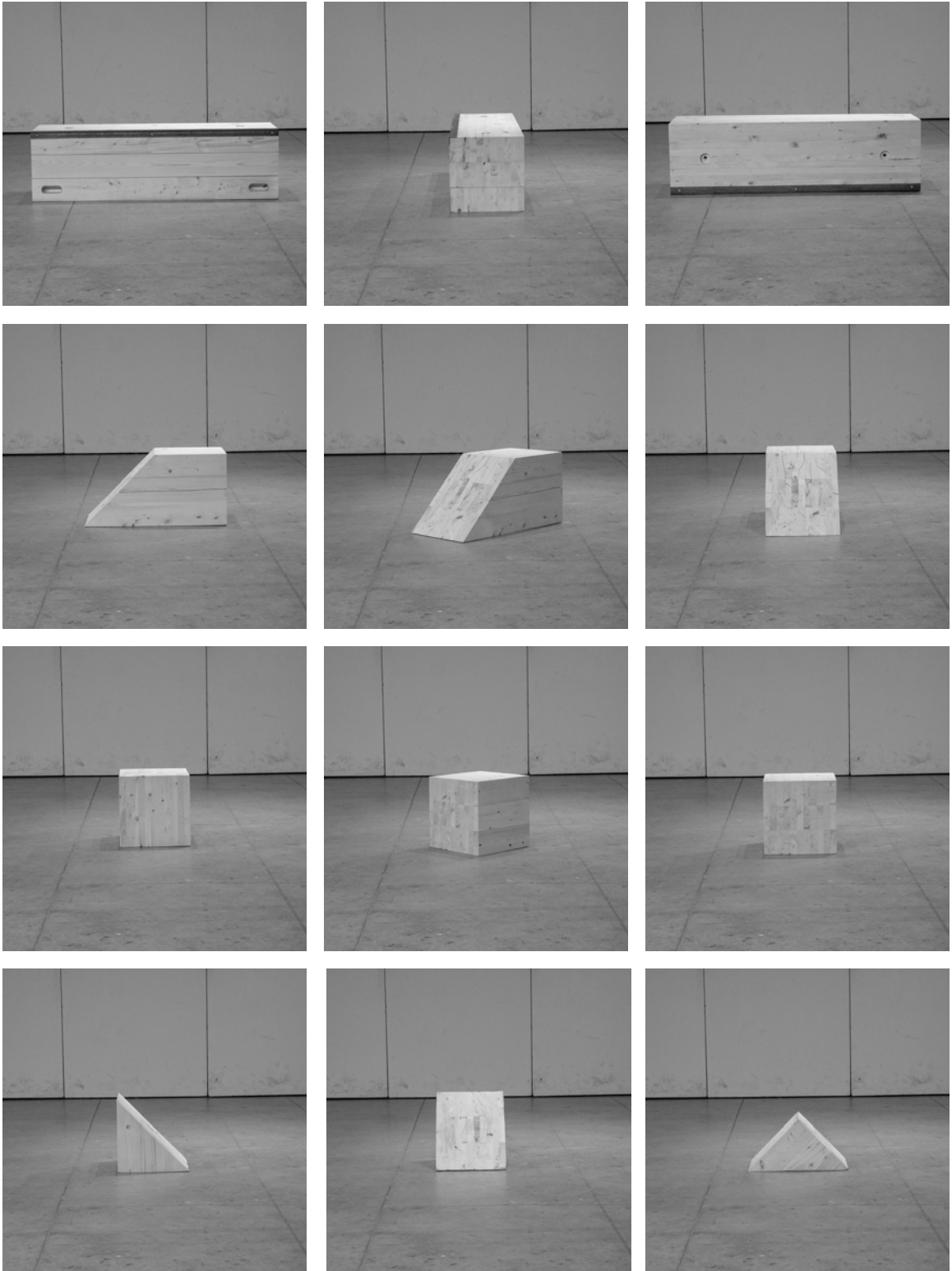

Objects of Skateable Desire: orthographic views.

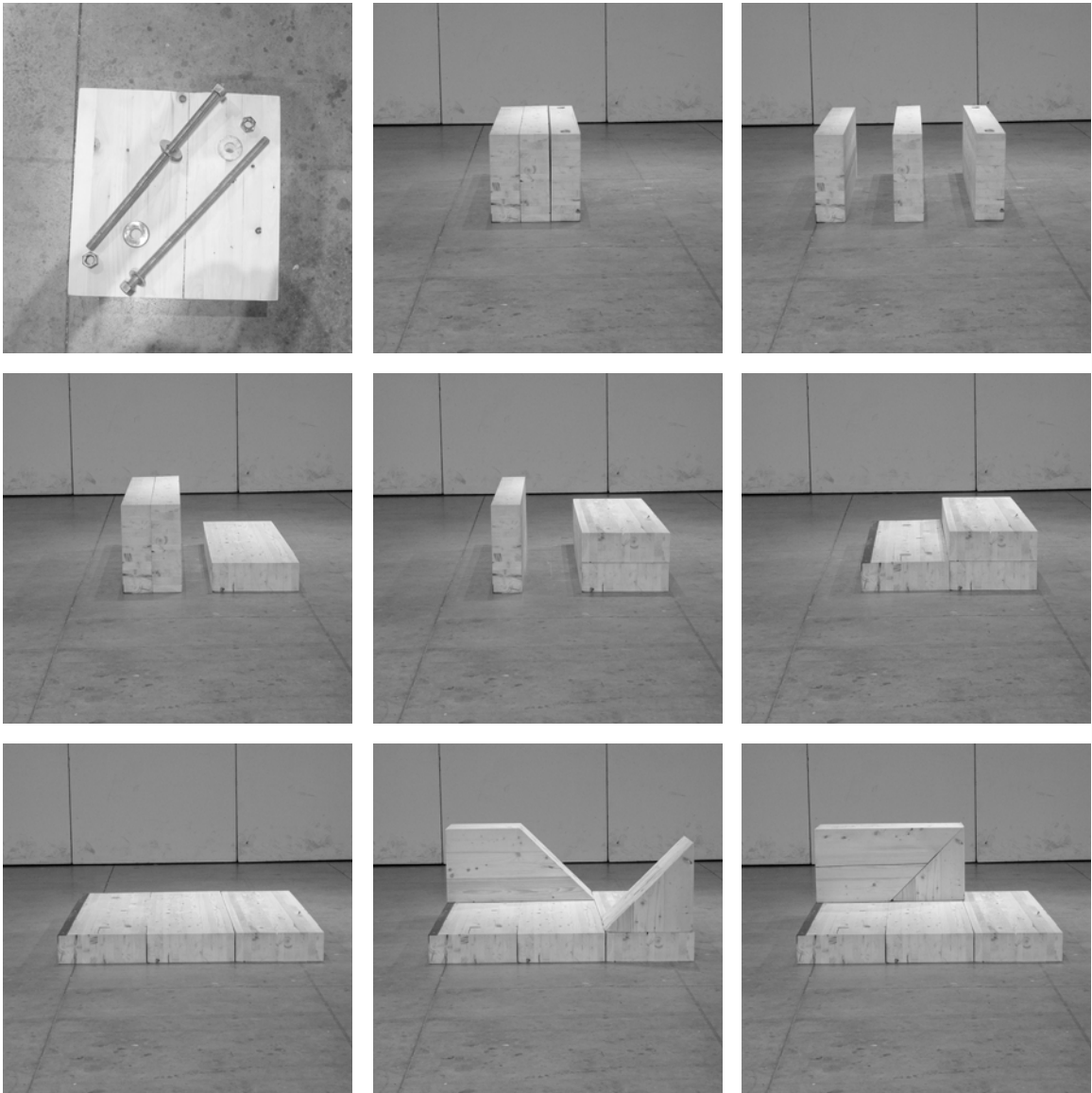

Objects of Skateable Desire: split + spread.

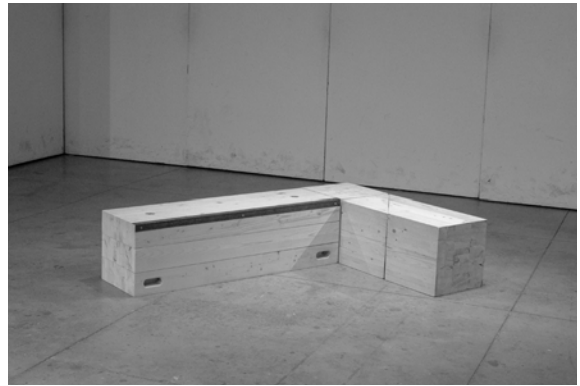

Objects of Skateable Desire: as bench.

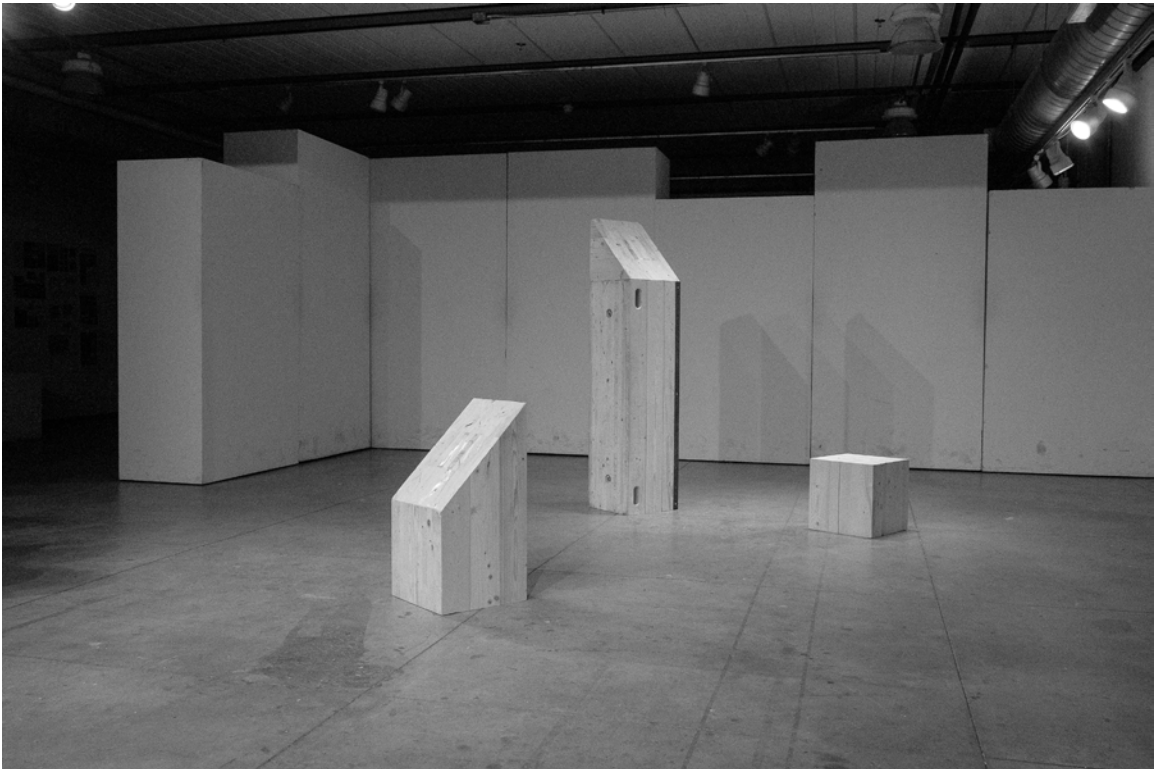
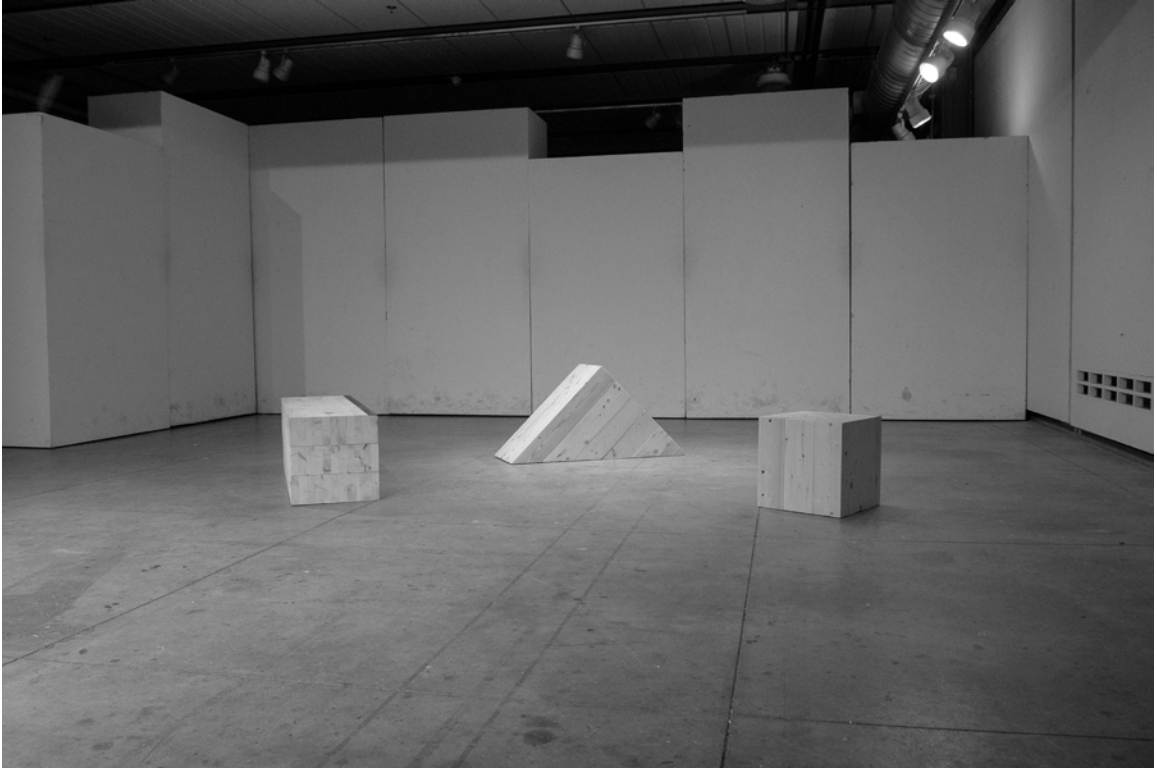

Objects of Skateable Desire: as sculpture.



Objects of Skateable Desire: as terrain.

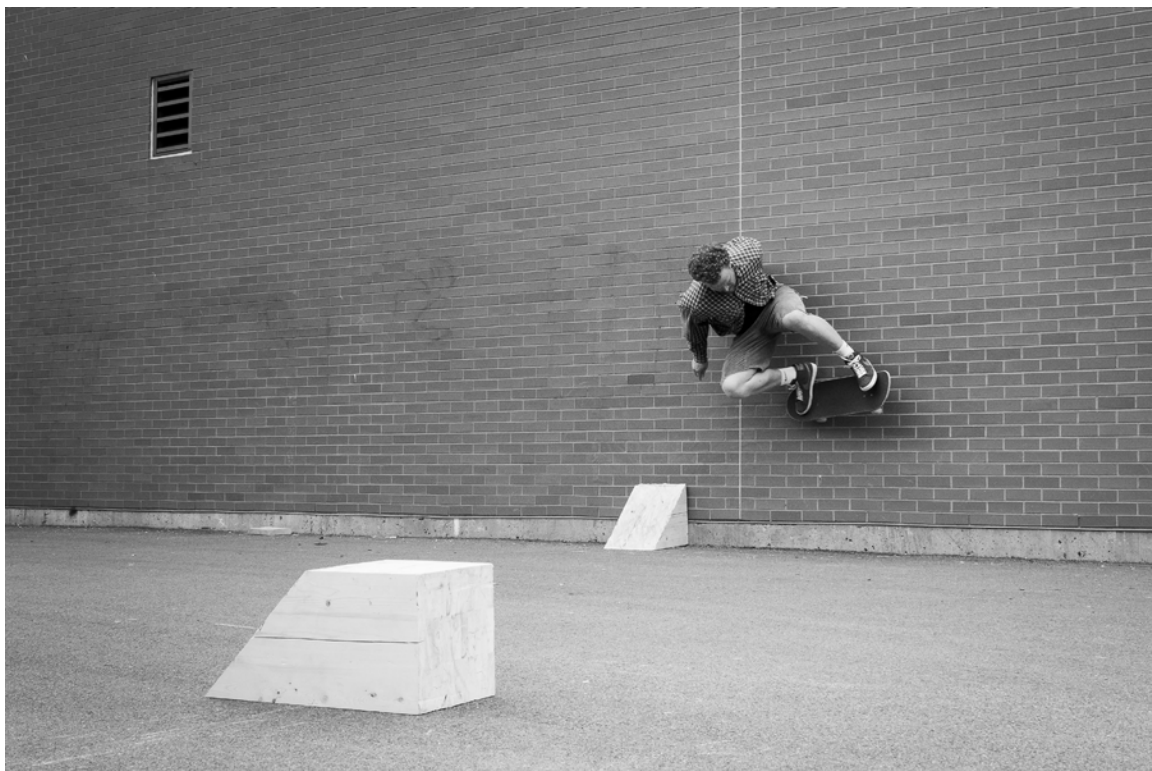
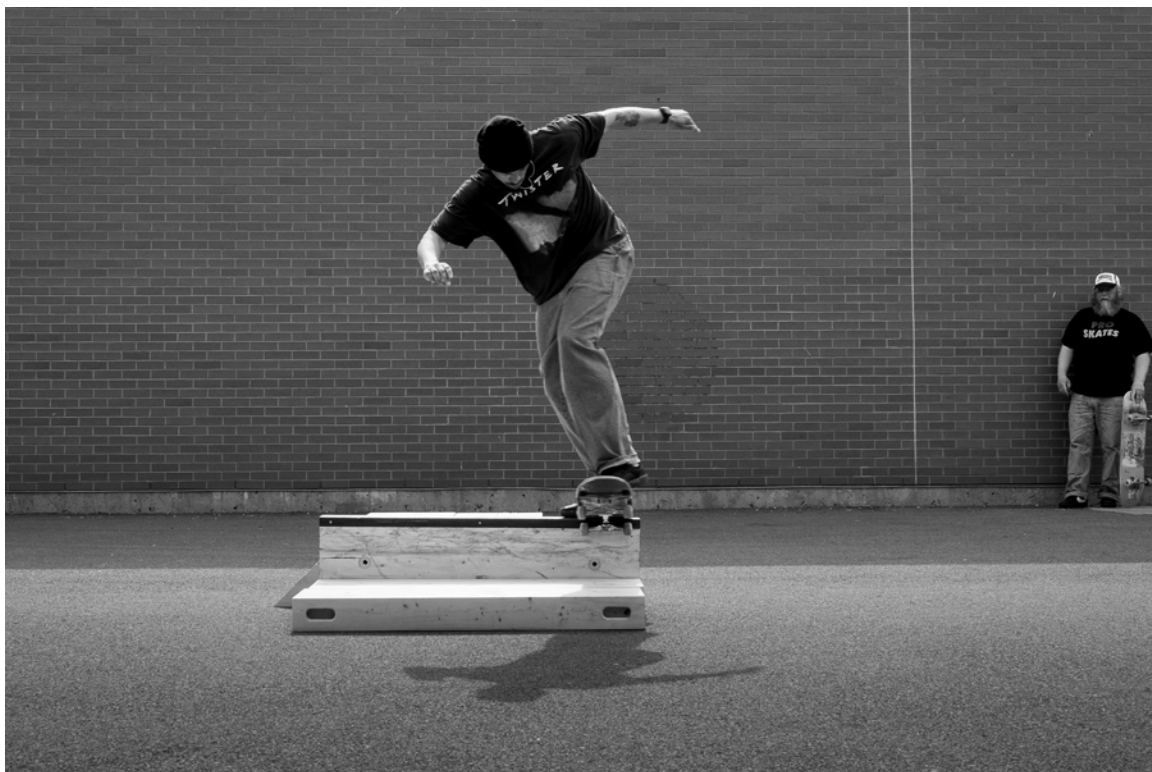

Objects of Skateable Desire: as terrain.



Objects of Skateable Desire: as terrain.



Objects of Skateable Desire: as terrain.





Objects of Skateable Desire: as terrain.



Objects of Skateable Desire: as terrain.

## Chapter 8: Design Proposal: A Network Hub at the Halifax Common Skating Oval



The Network Hub, imagined as a pavilion building with programmatic spaces supporting skateboarding's artistic adjacencies overlooking a skateable landscape plaza. 1:100 model.

### Selecting Site

In accordance with the urban strategy, the network hub being located in the Halifax Common makes sense. The Common is a highly visible public space that acts as the core for many of Halifax's outdoor activities, and includes

within its expansive lawns, softball and baseball diamonds, soccer and cricket pitches, tennis courts, a playground, an outdoor pool facility (in construction), and the existing municipal skatepark. It also is directly adjacent to Citadel High School, from which students frequent during lunch breaks and after school hours.

However, the skatepark itself requires updates, and is not up to the standards of modern skatepark design that should be present in the centerpiece of an urban skateboard strategy. Approximately half of the existing skatepark remains unrenovated since it was built in 1995 and is full of rough ground as well as decaying and obsolete features. The other half (added in a 2006 renovation) is full of cross flow patterns in the street section not conducive to crowds nor beginners, and the two large skatebowls have no easy “roll-in” option and no transition lower than 4’ (also not conducive to beginners). Further, the construction of the new outdoor swimming facility is encroaching on the existing skatepark’s space (see site plan), as well as creating drainage issues within the park by raising ground levels along its northwestern edge.

As such, the design proposes to move the skatepark from its current grounds into a skateable plaza space located at the center of the Common’s outdoor winter skating oval. The move to the center of the oval is threefold in logic: it bookends the oval with a building on the north side (blocking prevailing winter winds which affect ice-skaters); it grounds the common at its most undeveloped entrance at the North Park St. roundabout; and it fills a generally unused seasonal space within the Common (the center of the oval) with year-round function, wherein the winter the plaza can come alive as people watch the ice-skaters go round).

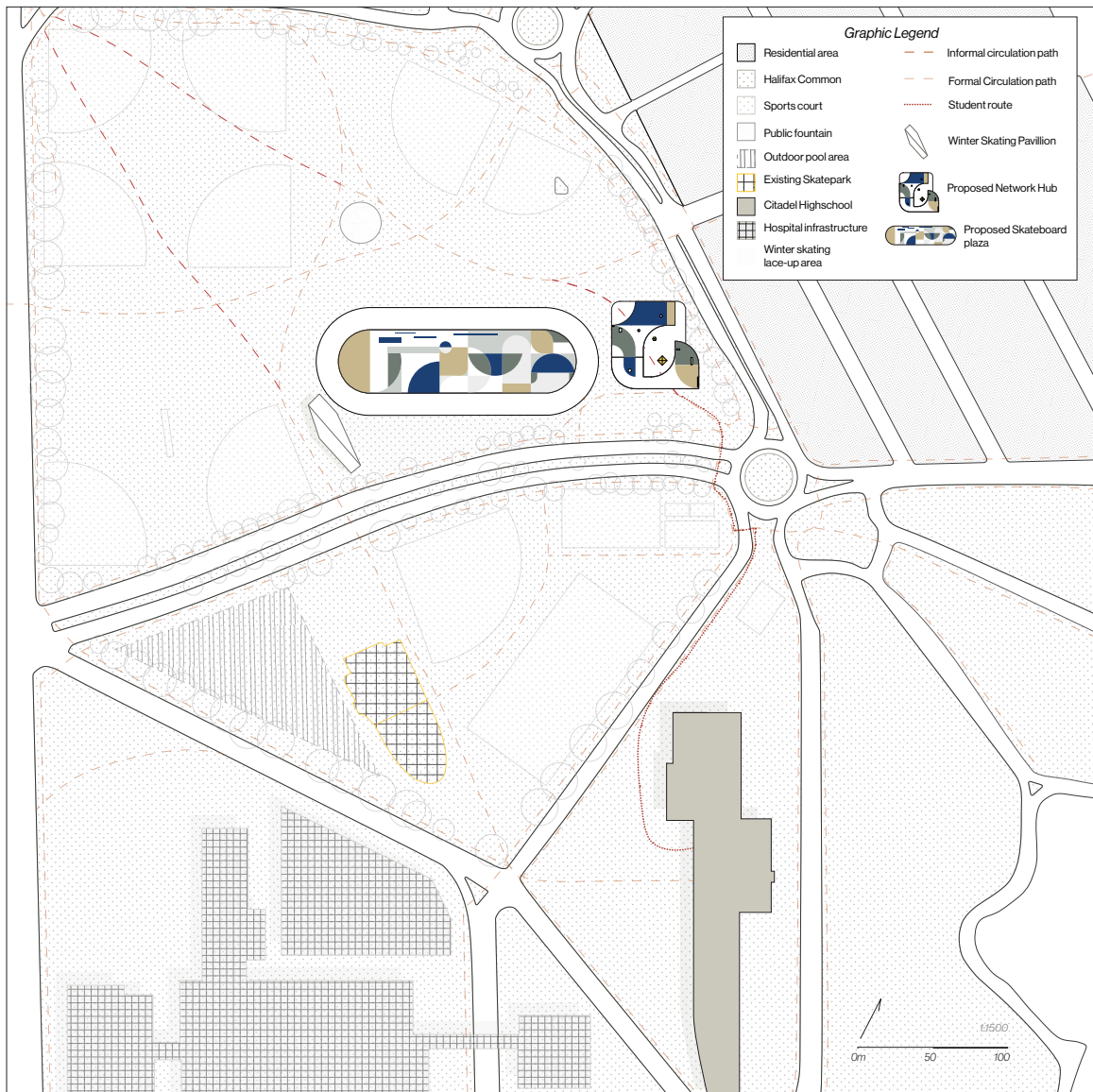

Network Hub, site plan. The existing skatepark is out of date and cramped in its current space, meriting the shift of the main skate amenity in Halifax to the center of the winter skating oval in the North Common.

## Program

The building site lies on the eastern side of the skating oval, on a small rise leading into the Common. The building is meant to support skateboarding, and has three primary programmatic drivers: building community, facilitating learning, and engaging with the arts. Each of the three buildings align with one of these programs, through a

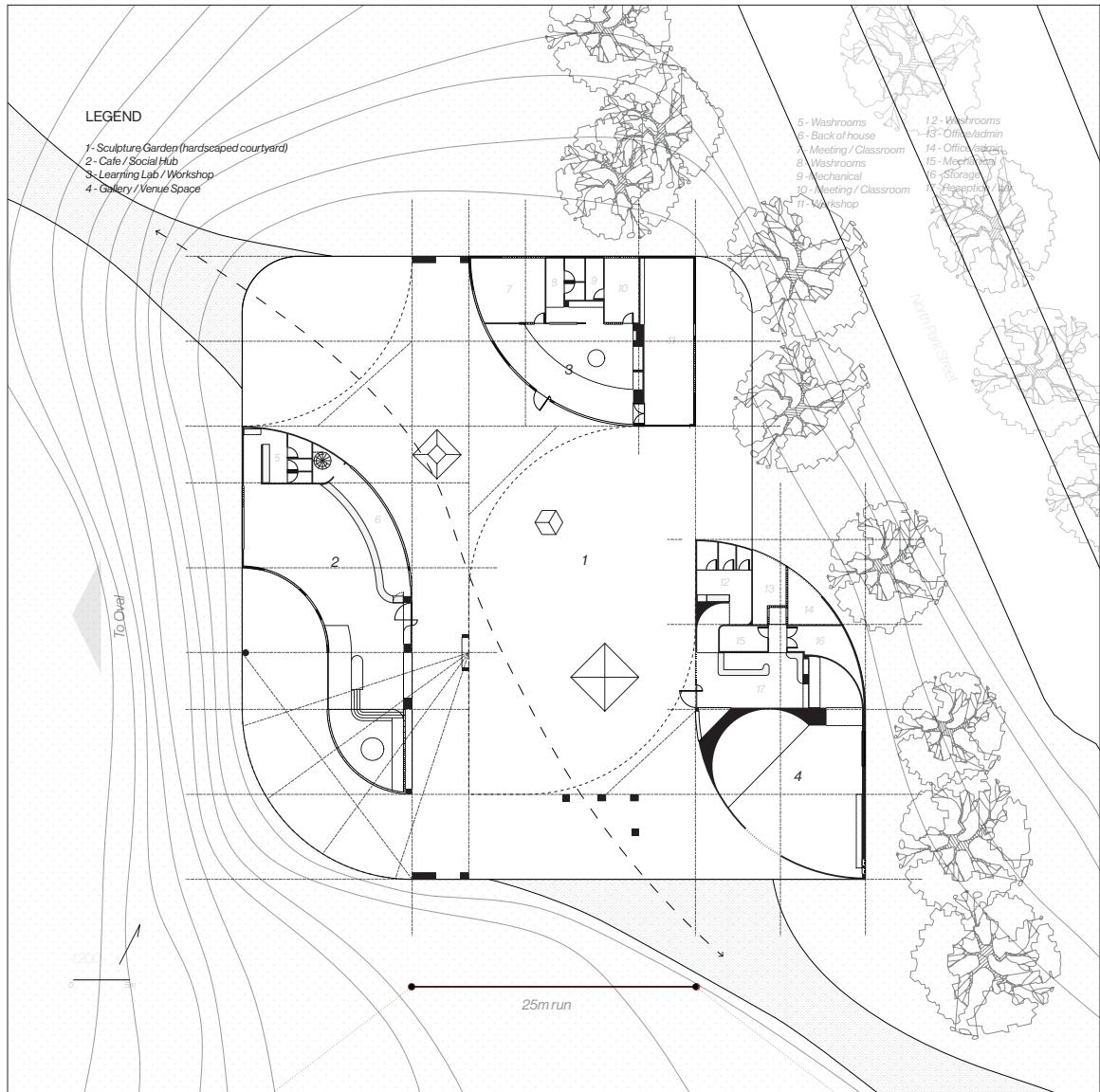

Network Hub, building plan. Minimum 25m runs of covered skateable space form important design parameters which help determine form.

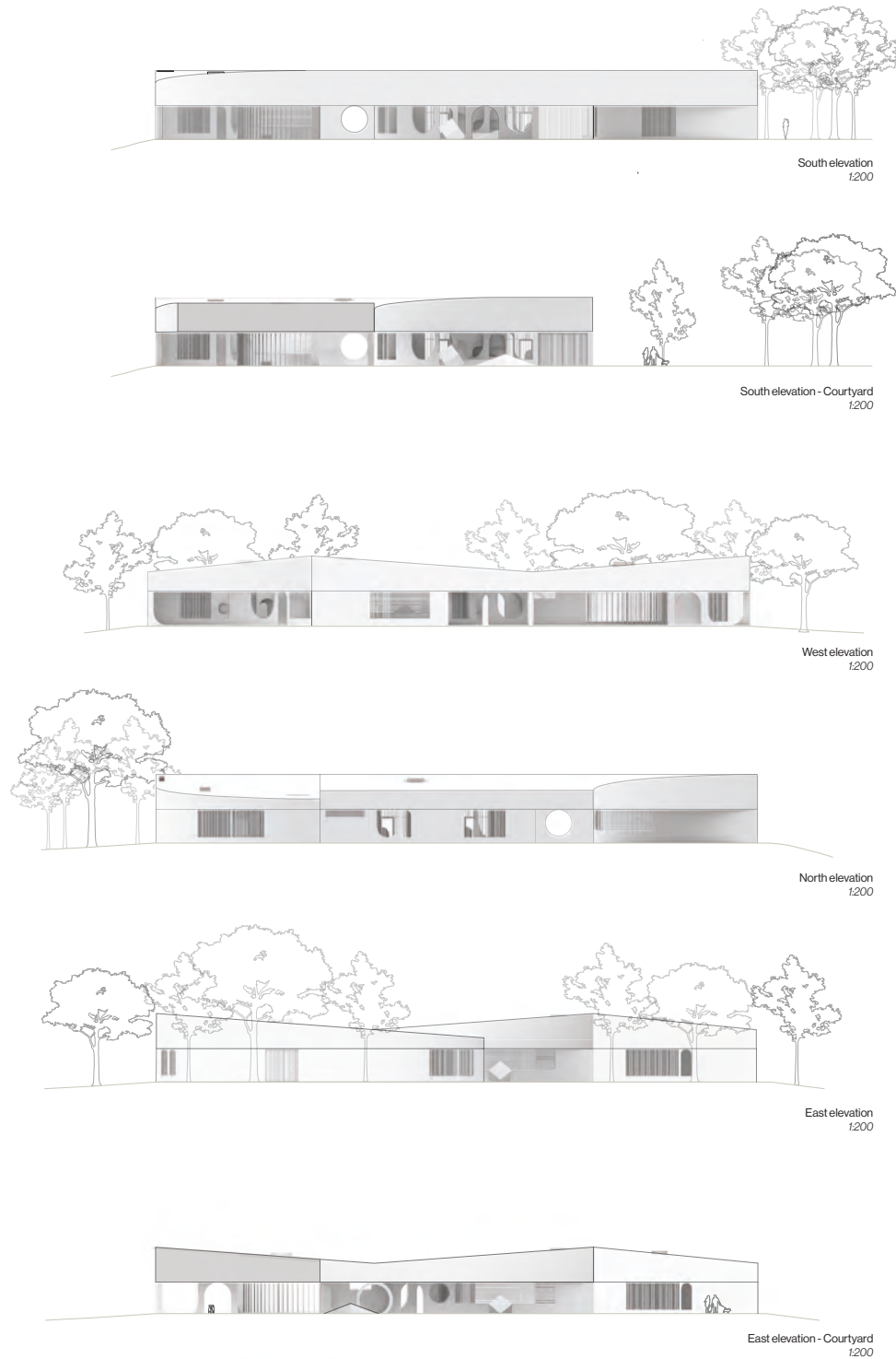

Network Hub, elevations. The elevations are marks of an architectural process.

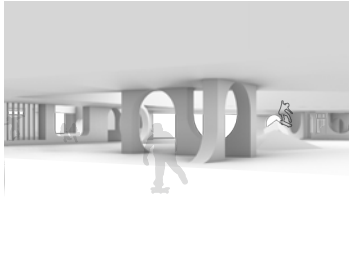

Courtyard

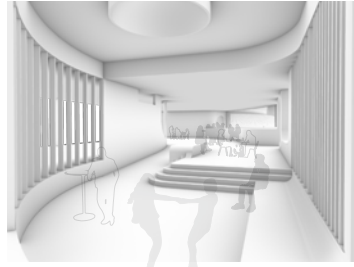

Cafe interior

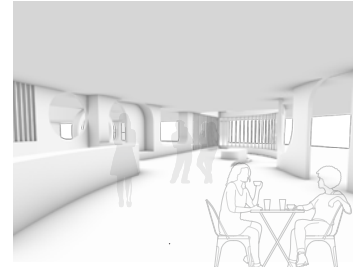

Cafe interior

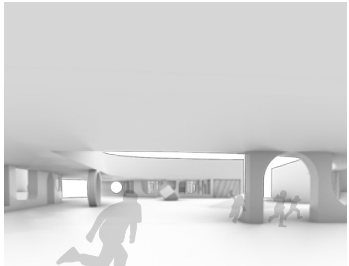

Courtyard

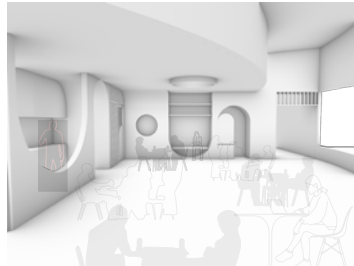

Learning lab interior



Learning lab interior

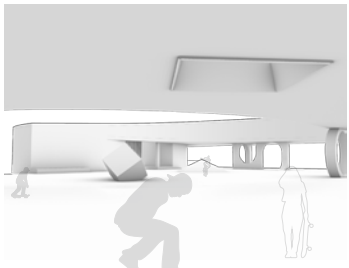

Courtyard

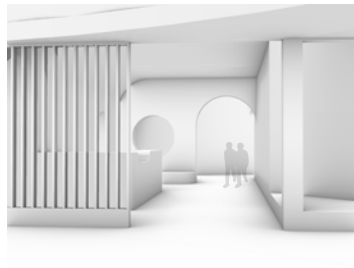

Gallery entrance

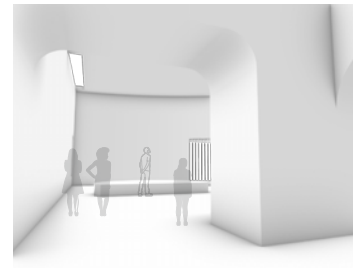

Gallery interior

Network Hub, conceptual renders.



Plan

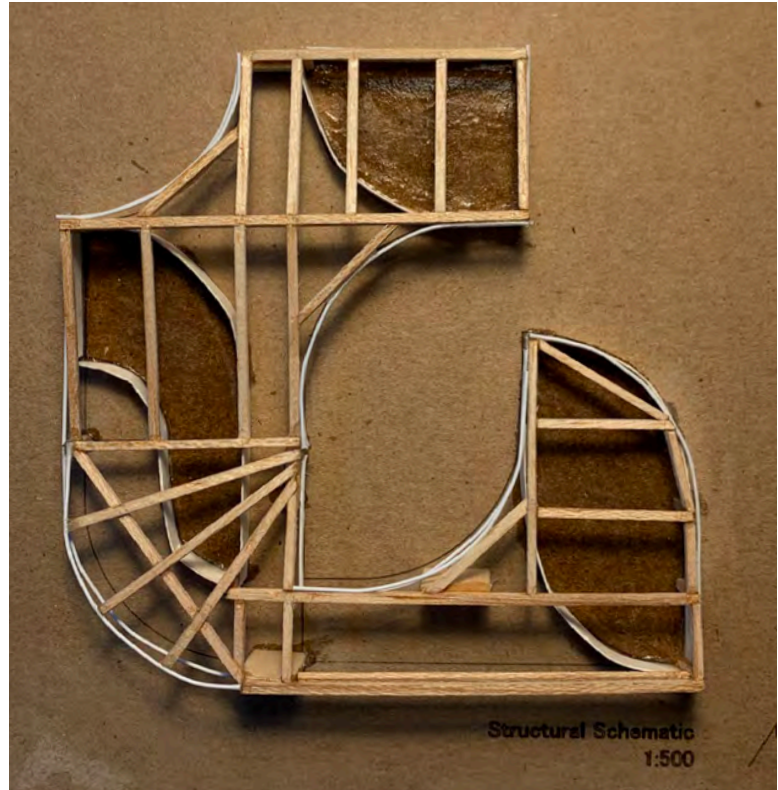

South Elevation

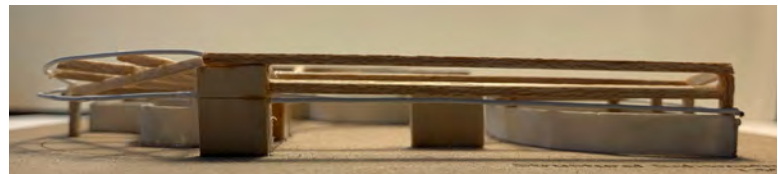

West Elevation



North Elevation



East Elevation



Network Hub, structural schematic model, 1:500

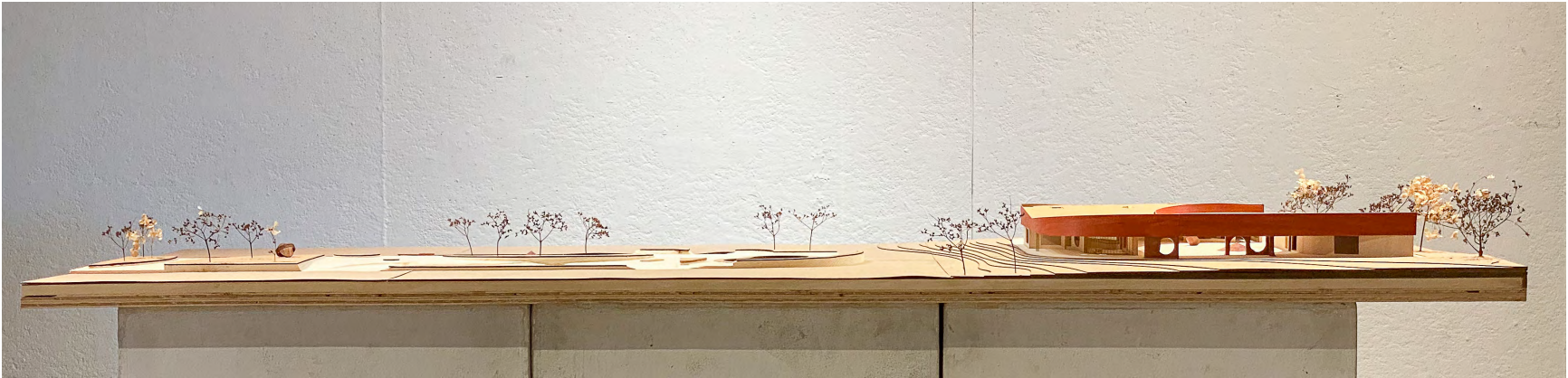

Network Hub: building and landscape plaza site model, south elevation view.



Network Hub: building model, south elevation view. A roof links three buildings, creating runs of covered skateable space below.

cafe/bar space, a “learning lab” with meeting rooms, work spaces, and a workshop, and a small gallery/exhibition building. A sculptural roof with curving form floats above three conditioned spaces and forms a courtyard between.

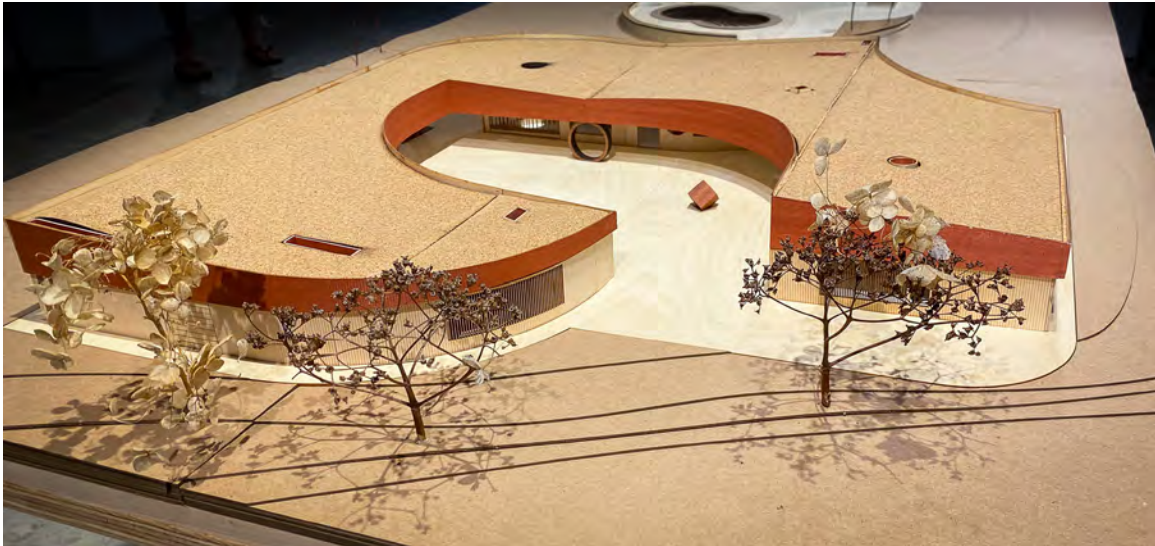

A roof links three buildings and their programs together: a social space, a space for learning, and a gallery space. View from NNE.

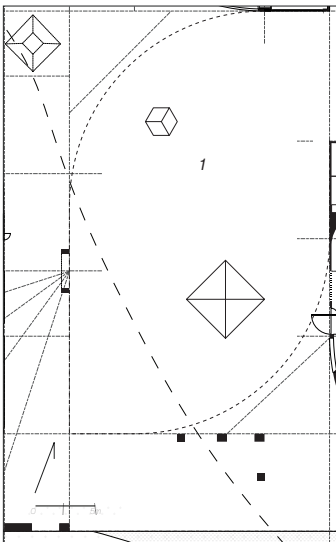

Courtyard, plan.

### Courtyard: Hardscaped Sculpture Garden

In the courtyard between the buildings is an open hardscape with skateable sculpture. The primary forms are a diamond (which forms a hip feature) and a cube, which allows potential for skaters to “wallride” or “wallie” off the side. Columns to support the roof are made sculptural, to either be enjoyed as art, played upon or within, or skated in various ways. Most of the courtyard is left open, allowing for it to function as a staging ground for events or as an outdoor exhibition space. It also works to maintain one of the prominent informal routes of pedestrian travel observed on site. The forms within the courtyard pay homage to Noguchi, particularly his Sunken Garden at the Yale Rare Book Library.



Courtyard, model photos. Sculpture and function intermingle as sculptural forms integrate aesthetics, skateable terrain, and structural support into an outdoor plaza.

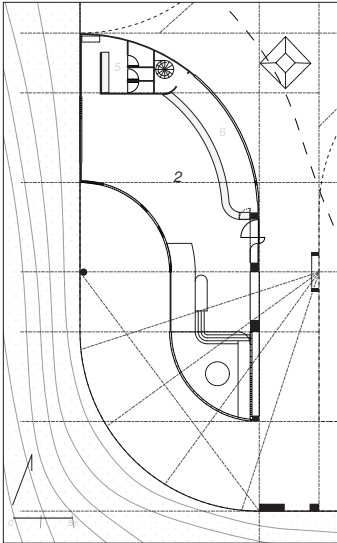

Cafe/bar, plan.

### Social Hub: Cafe + Bar Space

Overlooking the oval and the skate plaza within lies the social component of the complex: a cafe / bar space. A sunken floor and raised ceiling on the building's south end forms a threshold into a multi-valent space that can be used as a space for small performances, group meetings, or informal social gatherings. The permeable facade around that space provides a connection to the activities outside, while at the same time the slatted glazing provides a sense of intimacy to the interior. On the north end of the building, two doorways pass through the open floor space of the interchangeable

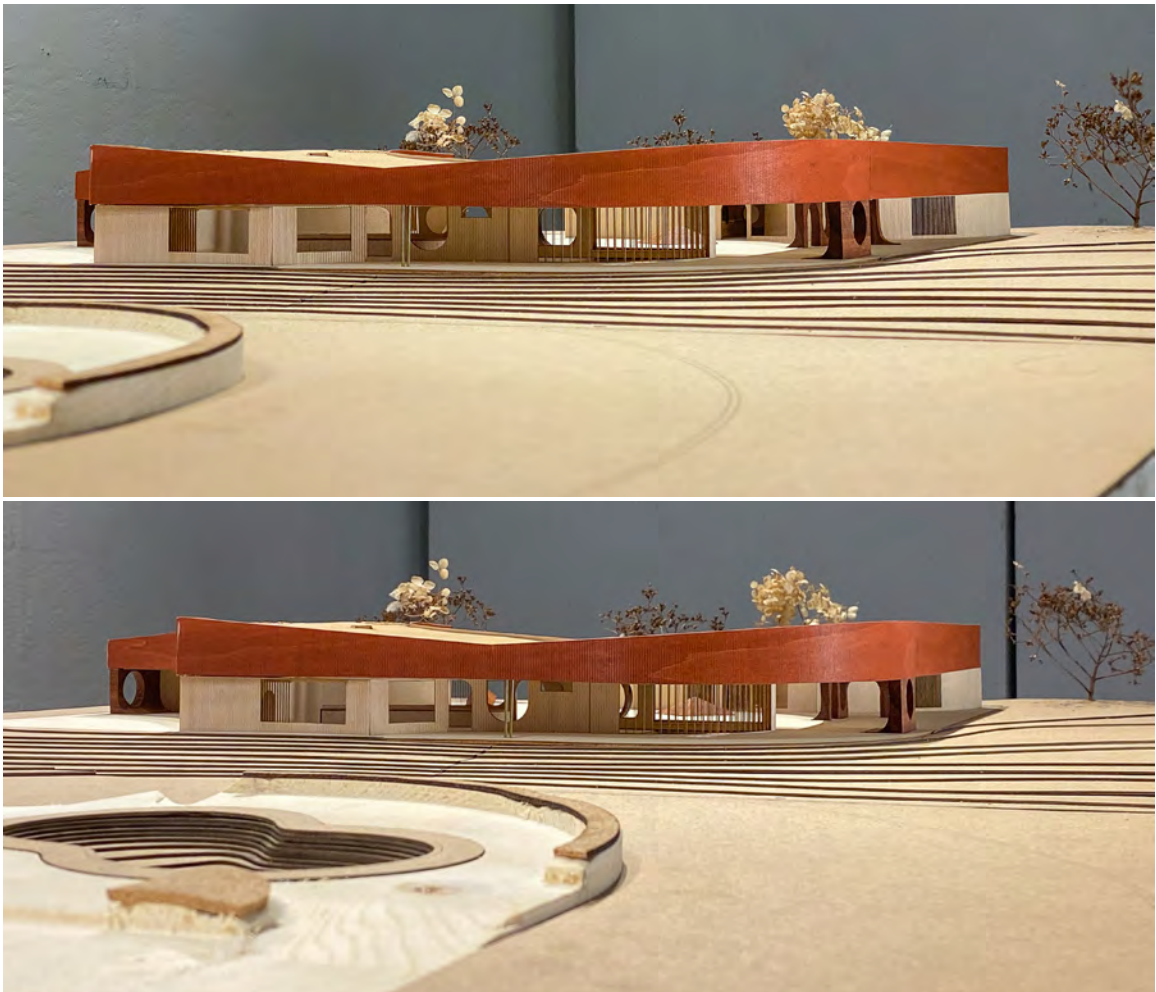

The placement of the cafe/bar building - which acts as the social foundation of the complex's programming - on the southwest side allows for connection and views to the plaza below in both summer and winter..

cafe/bar to the covered spaces outside, allowing for larger events to blur the lines between indoor/outdoor. The northwest corner of the building contains washrooms and services, with a small office space hidden above. Various skylights throughout the building allow natural light in and play with a sense of depth in the ceiling. In the winter, the



Doorways on an east/west axis allow cross flow through the space and for larger events to spill outside into covered spaces, while a skylight punctuates a raised ceiling above a sunken floor and marks a more intimate threshold on the building's southern tip. A ramp and stairs connect the spaces; the sunken floor allows occupants sitting inside the building to view any skateboarding taking place outside at eye level, engaging with it from a new perspective.

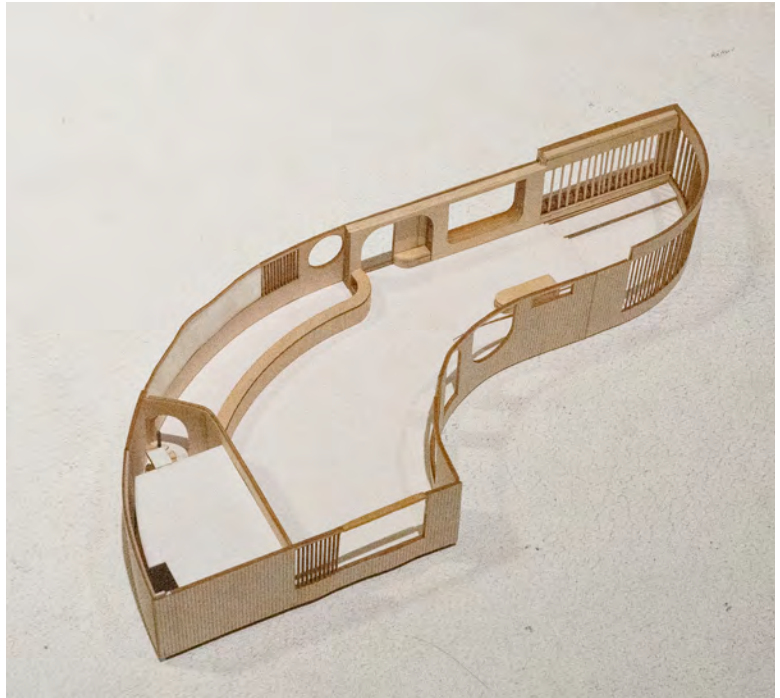
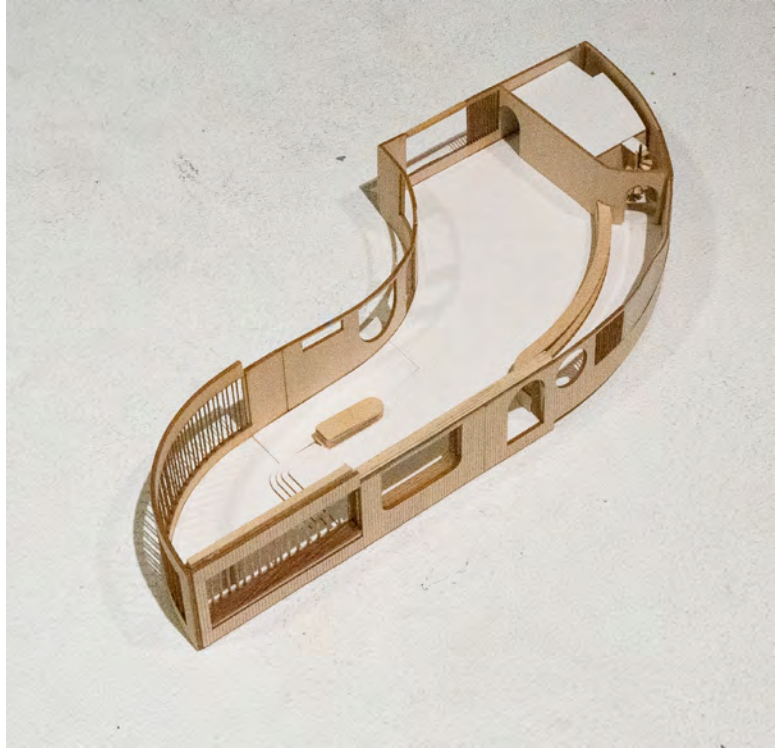

Cafe/Bar, model, 1:100.



Northwest entry corridor, with cafe/bar building on right, Learning Lab on left, and Gallery in background.

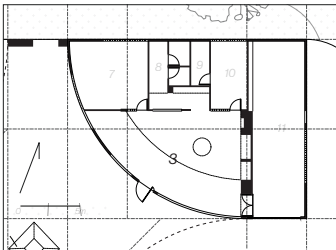

Learning Lab, plan.

space is auxillary to the ice-skating oval with clear views connecting to the ice-skaters below.

### **Learning Lab: Group Meeting and Teaching Space**

Forging connections and relationships and organizing beyond the bounds of the skatepark is a crucial aspect of this project. In order to grow inclusivity and diversity within skateboarding, space must be provided for groups, clubs, teams, or any sort of organizations based around skateboarding and to come together and grow within. These spaces need not be complex; the cafe/bar might meet some of the needs - but simple rooms where people can easily meet to discuss, organize, or create within are also necessary. This is the primary role of the Learning Lab: to provide safe and accessible spaces where people can learn, teach, create art, use computers, screen films, base youth programs from, build objects of various scales, and ultimately connect and expand in meaningful ways.

The Learning Lab has an indoor working or social space on its south side flanked by two rooms for meetings or classes, with a small kitchenette, washrooms, and storage between. These spaces are all permeable through large glazing to the courtyard and Common outside. Additionally,



a larger workshop space exists in the north corner of the building, allowing a physical place for skate-and-create to manifest itself. A garage door opens up into the courtyard, allowing for the act of creation to enliven the space outside. The workshop is envisioned as multi-functional, with basic

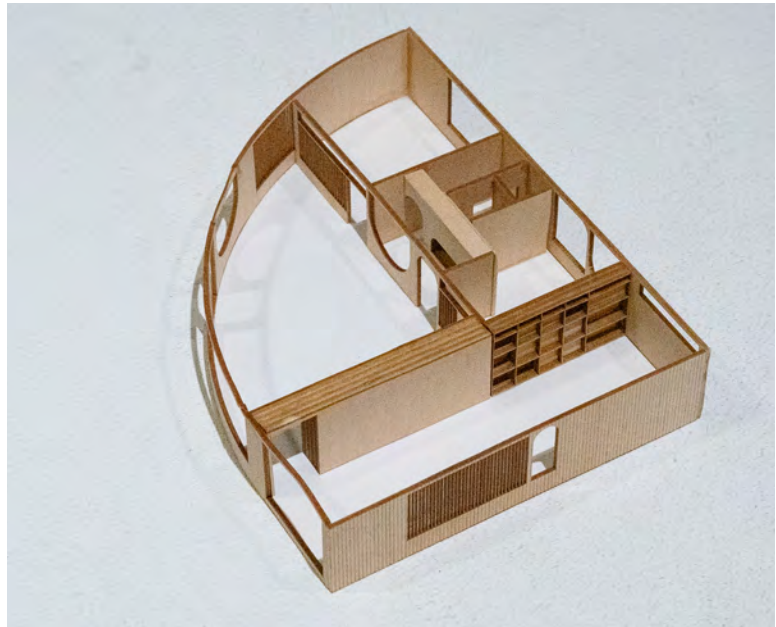
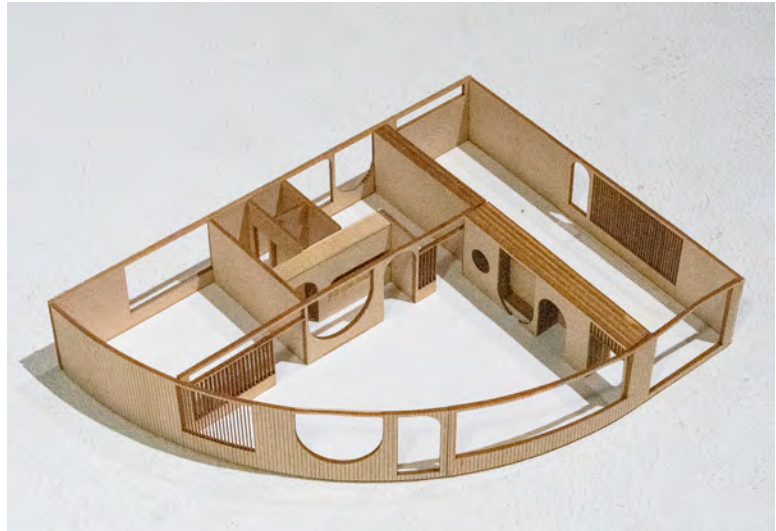

Learning Lab, model, 1:100.

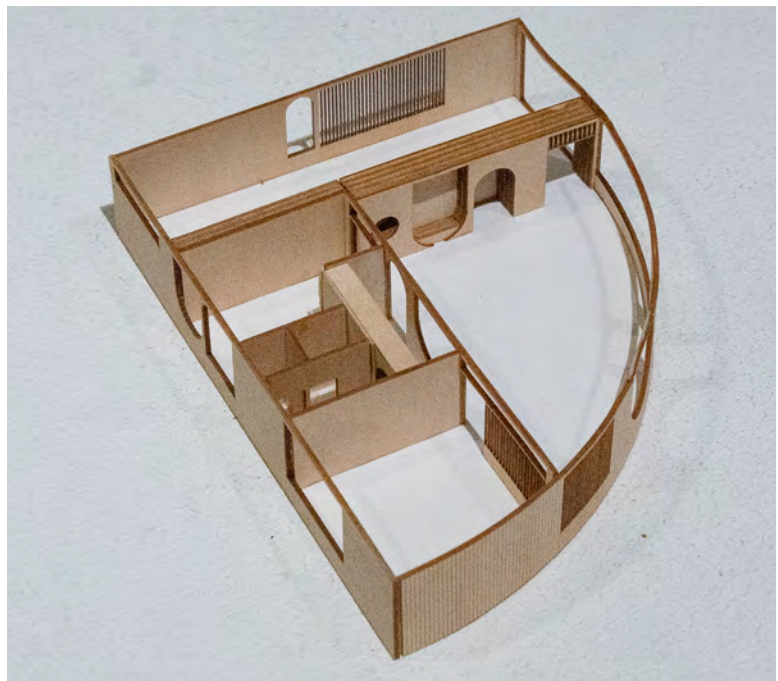
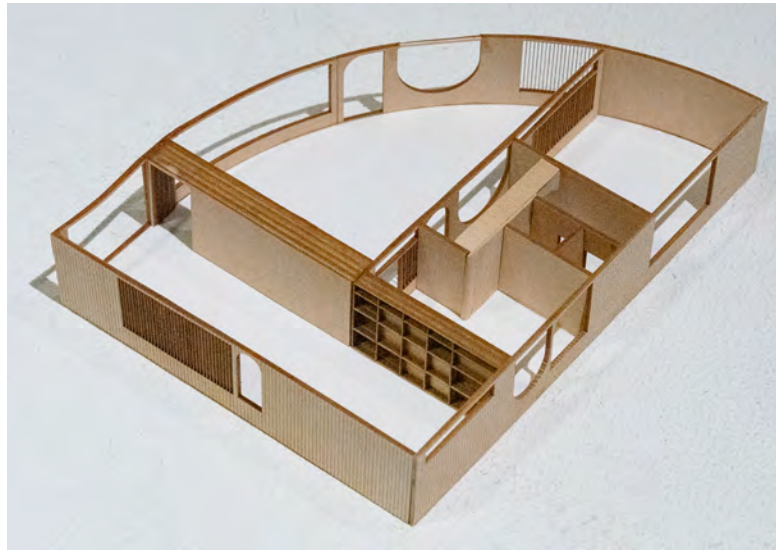

Learning Lab, model, 1:100.



North entry to courtyard, with Learning Lab on right and Gallery space on left.



East elevation, with Learning Lab building on right and Gallery building on left.

facilities for a variety of creative pursuits including wood and metal-working.

### Gallery

The Gallery building's main function is as an exhibition space, primarily to celebrate work produced within the skateboard community. The design is based around a reception area (that can moonlight as a bar for exhibitions or show openings), an administrative centre (two offices), a functional washroom and storage core, and an open gallery space. The curved gallery space features 14' high ceilings and a semi-circular area with 10' ceilings that can work as an audience corral for performance art shows. The idea of the space is to be small and functional while providing an appropriate venue for work created in the learning lab to be showcased. Minimal glazing and generous skylights balance ample wall space and natural light within the space.

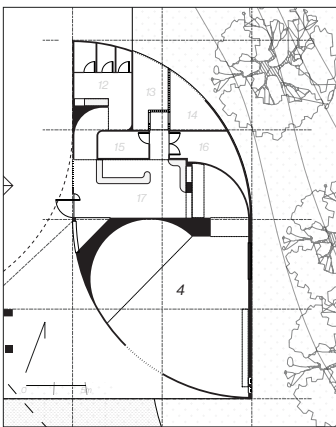

Gallery, plan.

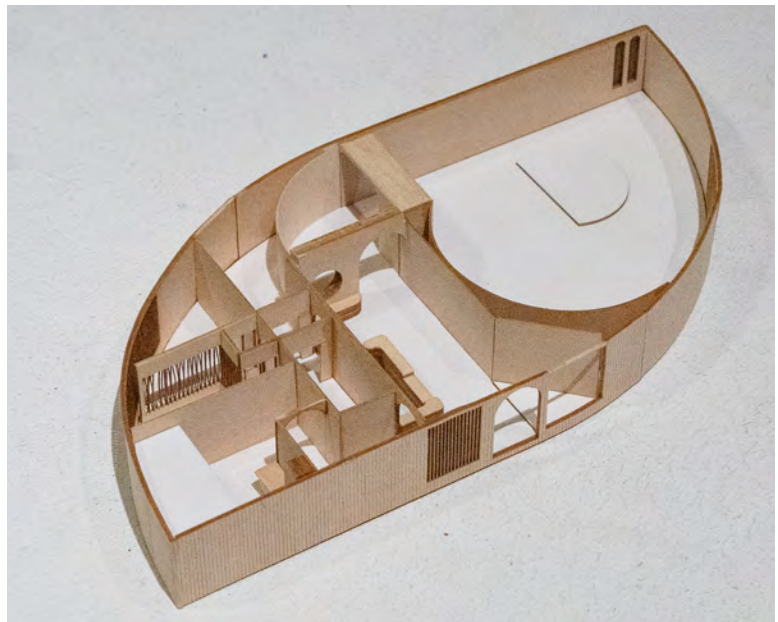
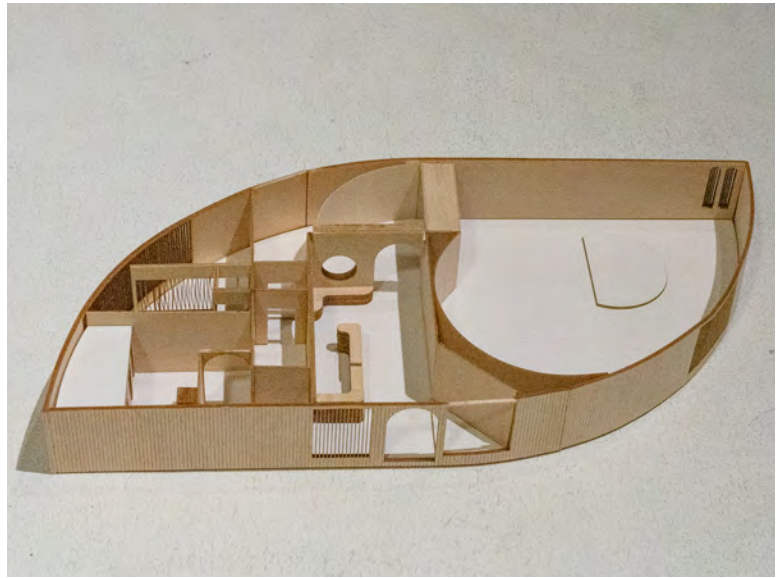

Gallery, model, 1:100.

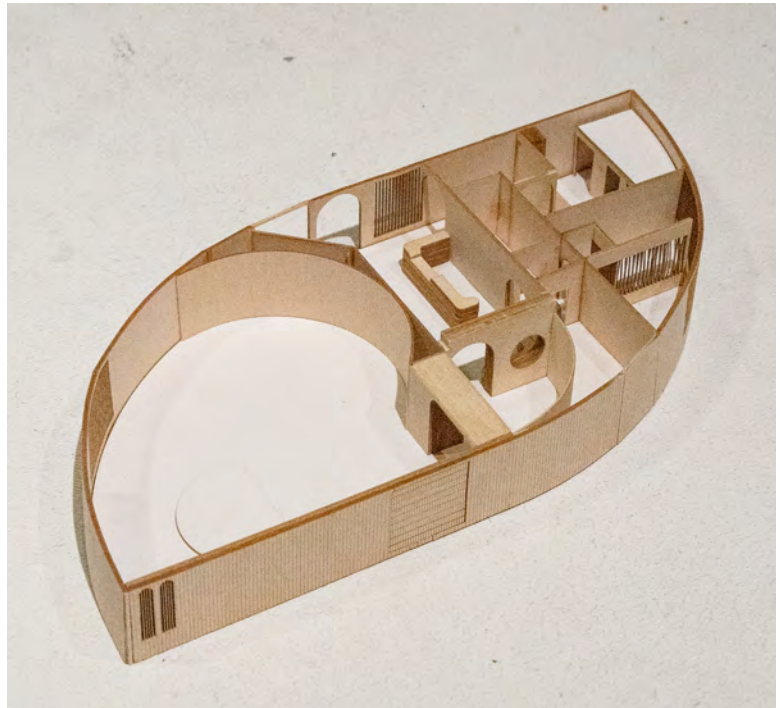
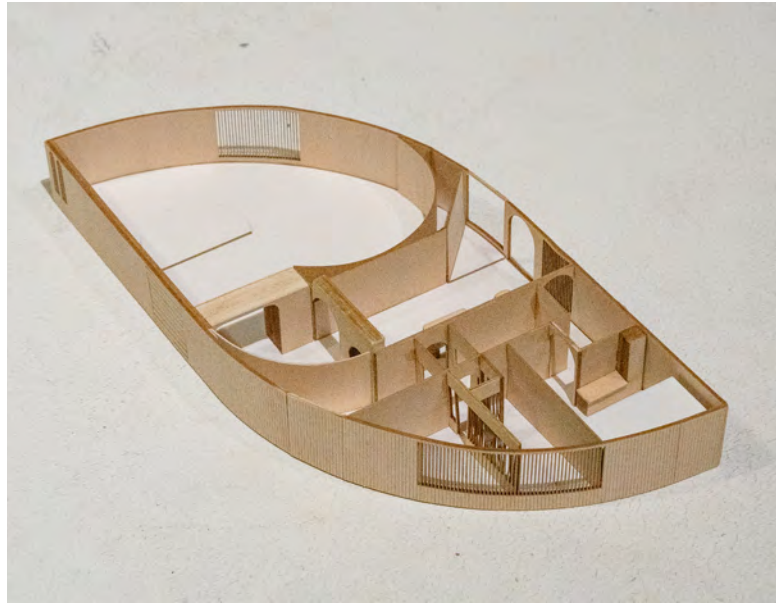

Gallery, model, 1:100.

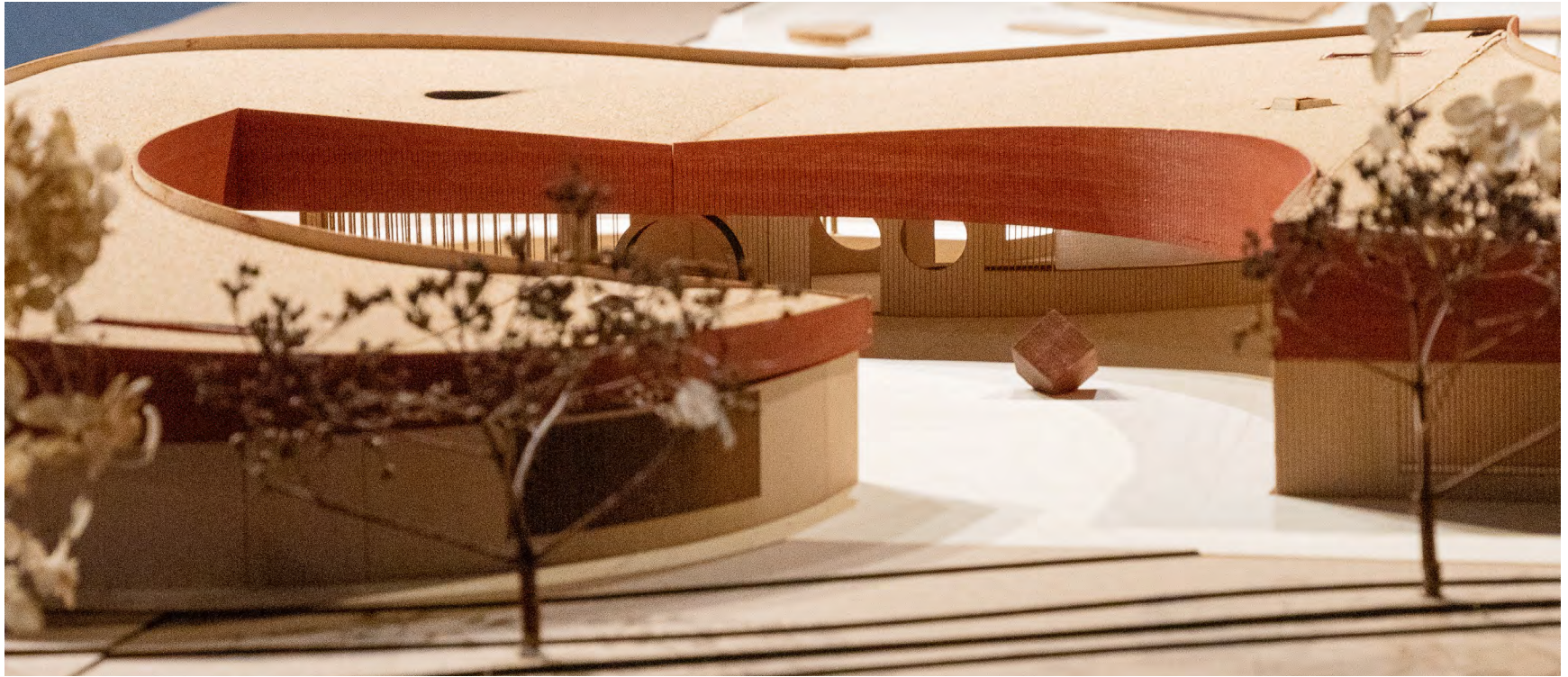

Network Hub, model, 1:100. View of north courtyard entrance.

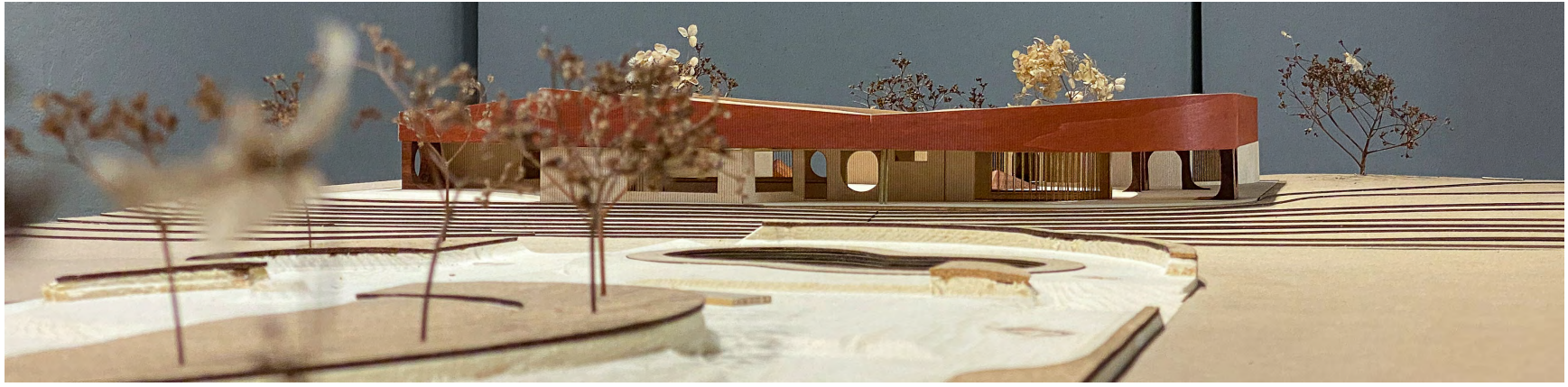

Network Hub, model, 1:100. Views of west elevation and plaza.



Skate plaza, aerial perspective view. The main skateable landscape for the project is located within the center of the seasonal skating oval. On the left (north) is a street style corridor with banks, ledges, rails, and minimal patterns of cross-flow. The landscaped islands in the middle offer buffers between spaces, guiding pathways of movement and providing informal thresholds of space. On the right side, a flow area with small transitions (good for beginners) leads to a more traditional skate bowl.

Moving towards the bottom of the image (west), open areas of flat ground are included for beginners to sharpen their skills in areas buffered from main pathways of movement. The entire plaza is accessible through ramps between its changes in elevation.



## Chapter 9: Conclusion

The act of skateboarding and the act of design run parallel: both are a combination of some part intuition and some part logic. Learning something on a skateboard is a sequential process that involves an initial attempt and a series of subsequent revisions (until a satisfactory result is produced). Sometimes, when attempting a trick the board will flip or turn in an unexpected way, which can in turn inspire a new trick: the process and its results are inversely related. Even a change of mindset or a change of mental focus can produce different results within the same frameworks. In skateboarding, shifting one's focus to how the foot flicks off of the nose instead of watching how the board rotates in the air might result in a different execution of the same trick. Similarly, elevating a certain design parameter (accessibility, for example) might result in a different design outcome for the same building.

The process of design for the building created in this project was unlike any design process I have engaged in before. There was no initial parti that set up the project; in fact, there was never a parti. Instead, it was a constant layering of perceived successes and learnings that lead to the final design.

First, came the mapping of space that a skater requires: a parameter of movement, not yet translated to form. Next, came the layering of possibilities for massing within that parameter: how could things be arranged so as not to negatively impact pathways of flow? Once possible arrangements were loosely organized on site, program was brought forward: which arrangements best suited themselves to the list of spaces required or desired?

In this way, the process of design was parallel to the process of skateboarding. While I intended to design a building, I didn't intend to design *this* building; it happened naturally. The tweaks, revisions, and advancement of design relied on work completed or ideas explored previously. It was a series of building blocks that were stacked in sequential order to create an end product.

Similarly, to execute a kickflip, a skater must first possess the ability to roll atop the skateboard before perfecting the movement of an the ollie. Only then can the kickflip begin to be realistically considered. Skateboarding starts with a foundation, which individuals build endlessly upon in their own ways. Architectural process begins with a concept, which evolves as the project advances.

As I designed, I trusted intuition. Curves and movement are intrinsic to skateboarding, so I allowed these to be drivers in the design. Rigid corners such are generally not conducive to skateboarding, so these were avoided where possible in the plan. Riding on a skateboard makes one aware of the small details of material and space, so I focused on creating little details that reflected the language of movement and curvature (which evolved as I designed the spaces).

Skateboarding – like design – requires trust in the process and trust in oneself. While a designer exposes themselves to criticism, rebuke, or even failure when presenting their work, a skateboarder exposes themselves to physical pain or injury through their practice – yet they both trust their abilities and experiences to guide them toward success. Rather than having a set goal for what I wanted this project to be, I trusted it to evolve organically and systematically. I worked at a process, rather than a product.

Personally, skateboarding is something that I enjoy doing. However, it is also something that has developed the characteristics necessary for me to design space. Creativity, ingenuity, determination, repetition, trust, grit (or conversely, the ability to let go and move on), attention to detail; these are all widely applicable to any process involving “work” and goals. Perhaps this is skateboarding’s greatest asset: it unconsciously moulds skills that are foundational to success in any setting. Understanding that difficult things take time and effort – but that they can also be incredibly rewarding (and unlock countless new opportunities) – is something that skateboarding allows people to discover in their own way. While people can give helpful tips and share what works for them, skateboarding is impossible to have somebody do for you. As a result, it teaches you to believe in – and trust – yourself.

Skateboarding can bring people together instantly with a simple shared experience, and provide a tool for learning about the city and about the people inhabiting it (whoever they may be). Public space contains unlimited potential when seen through a skateboarder’s lens. The sidewalks, streets, plazas, pathways and squares of cities are playgrounds for those who choose to see them as such.

Incorporating skateboarding into our cities is easy: we just need to let it happen, and occasionally celebrate it. While not every person should ride a skateboard, every person should know the value of skateboarding – or at the very least, not have an urban environment which perpetuates a myth that skateboarding has no value. Skateboarding has *immense* value. By designing or enhancing public spaces to be skate-friendly, urban public space can recognize, consider, and communicate skateboarding’s value to the wider public.

Architects, planners, and builders construct cities; at the same time, skateboarders reconstruct them anew. A skateboard is a toy, but also a lens for seeing, finding, and acting upon potential. It is a means of bringing people together. Public space is shared; it should be shared equitably. Bikes and scooters (even electric wheels) are accepted as the future of transit within our cities. Skateboards serve all the same functions - yet they can be so much more. People don't ride skateboards to create ruckus; people ride skateboards because they enjoy it. In designing for skateboarding, we allow people to transform what their environments – as well as what their futures – hold.

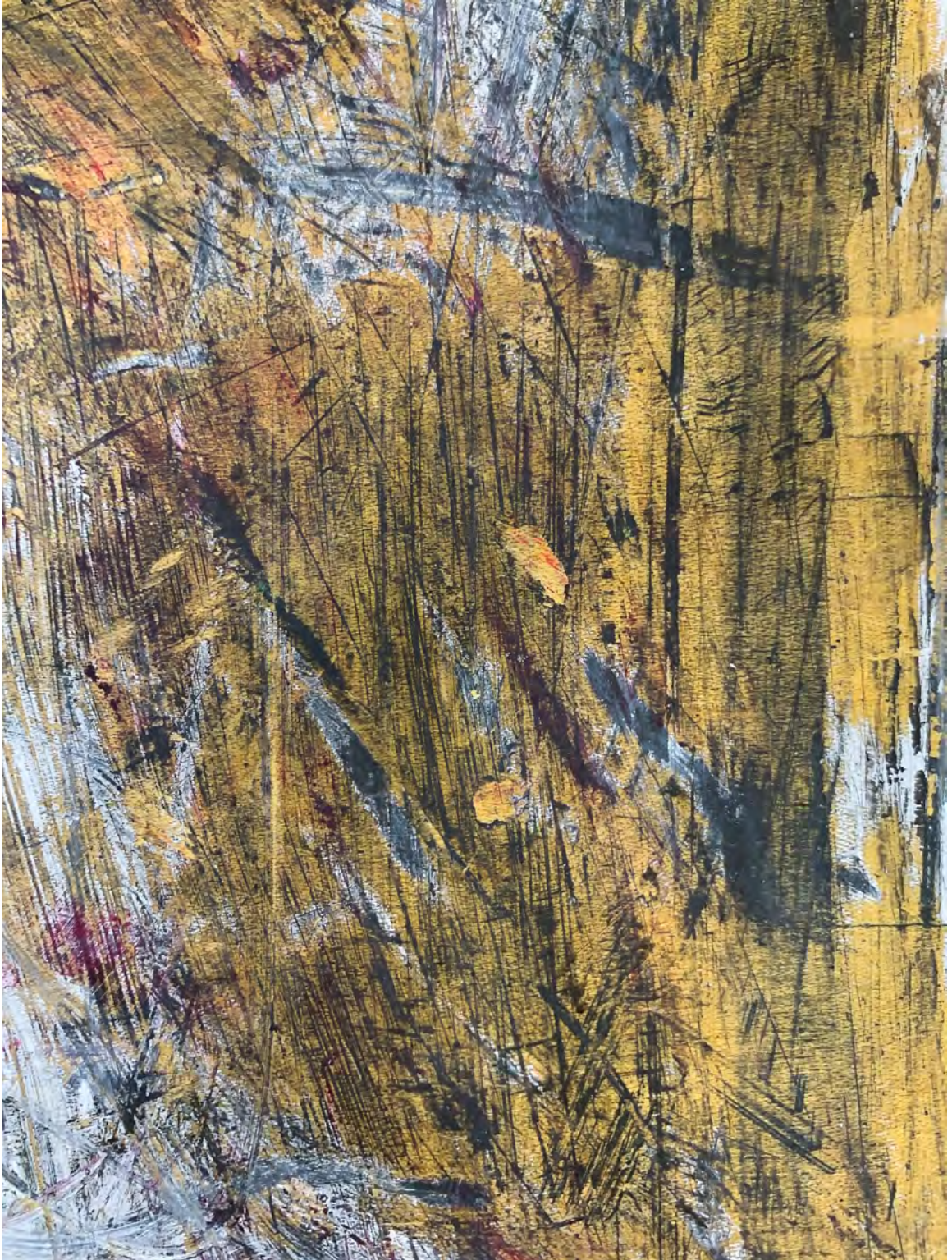

On process: the markings on a skateboard carry stories, places, and movements past.

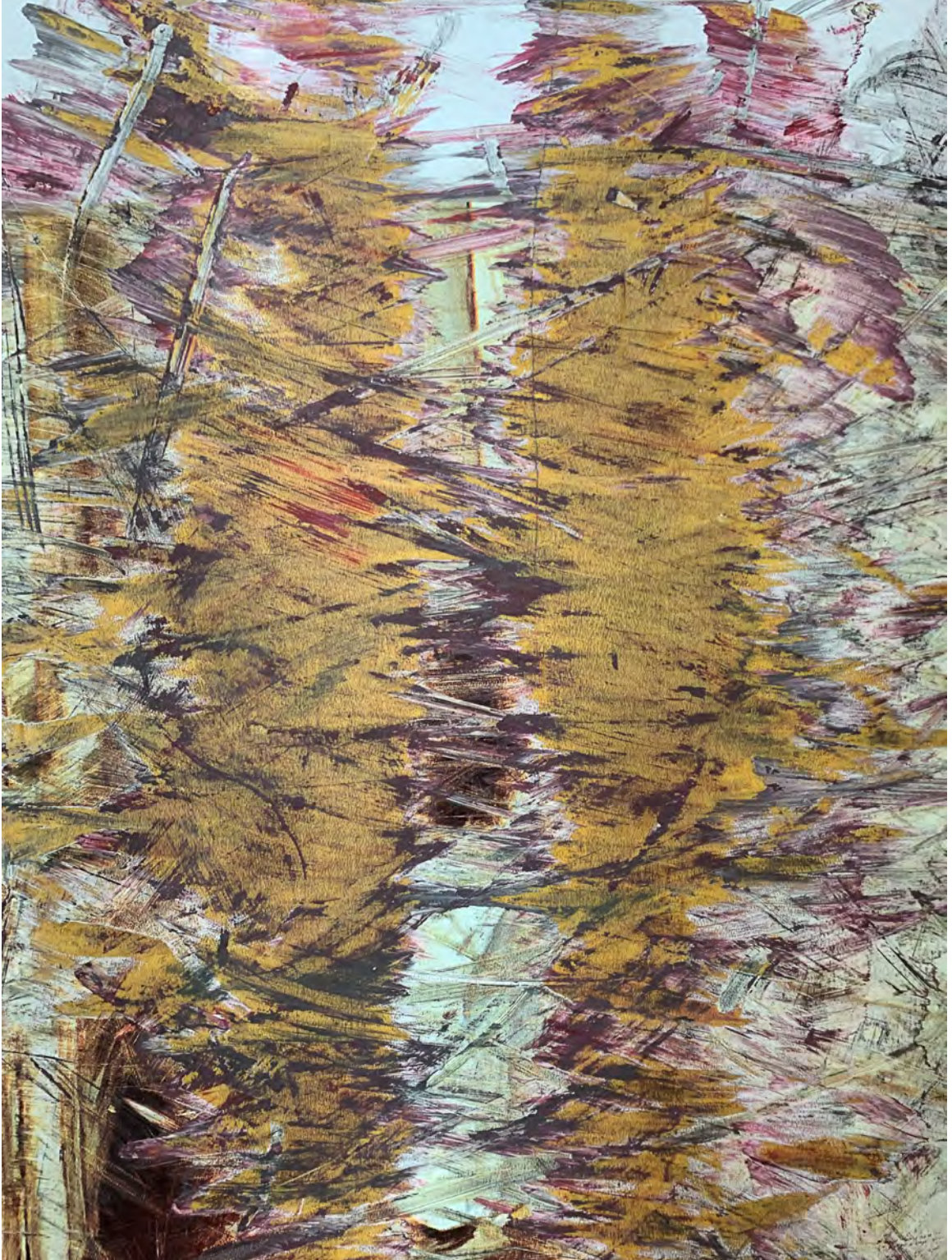

On process: like layers of trace, a skateboard is a record of a thought, action, or movement.

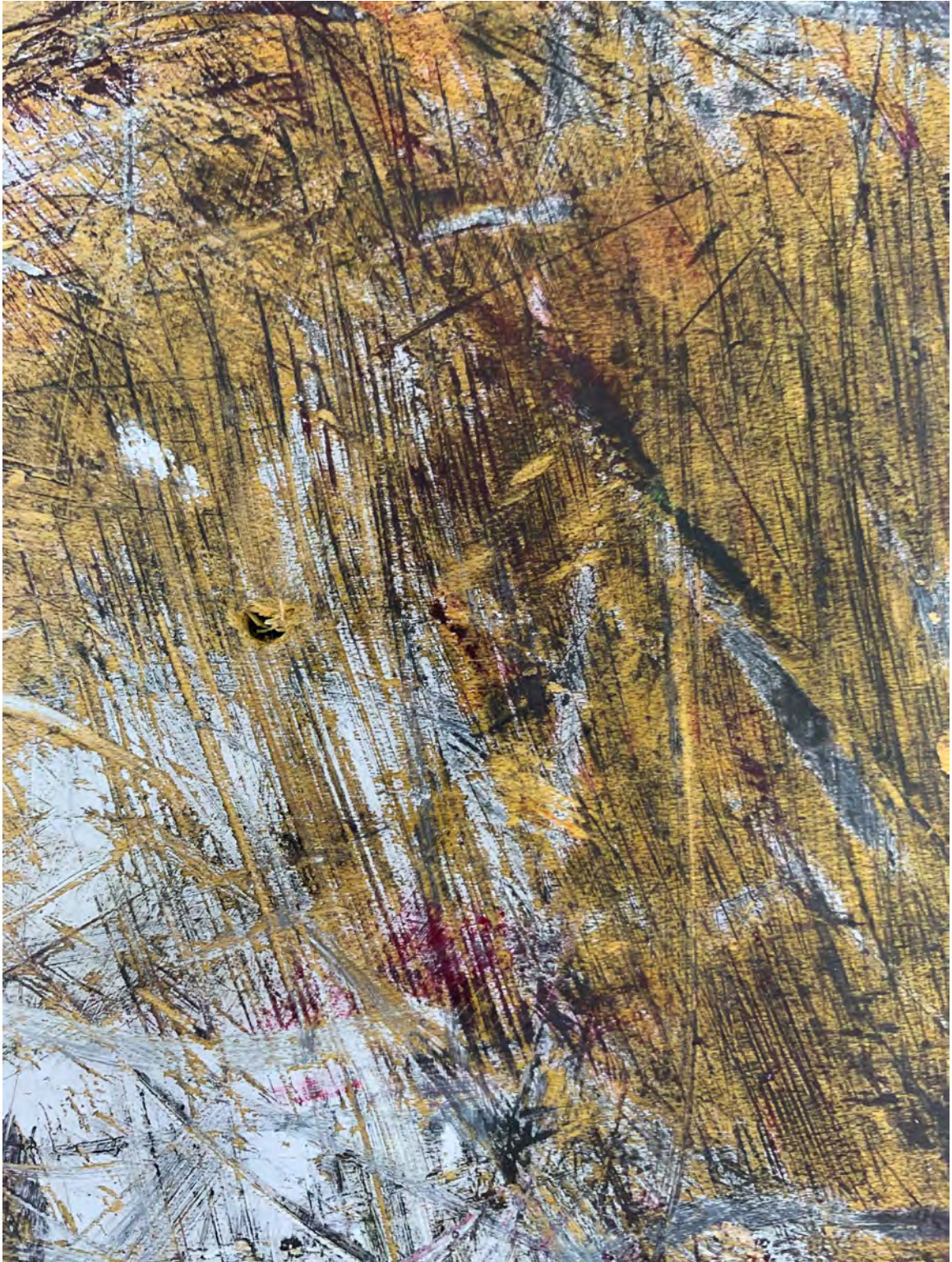

Each line on the skateboard corresponds to a specific time, place, and movement; the skateboard is an object of memory.



Traces: marks of a kinetic process.





Traces: marks of a kinetic process.



Traces: marks of a kinetic process.

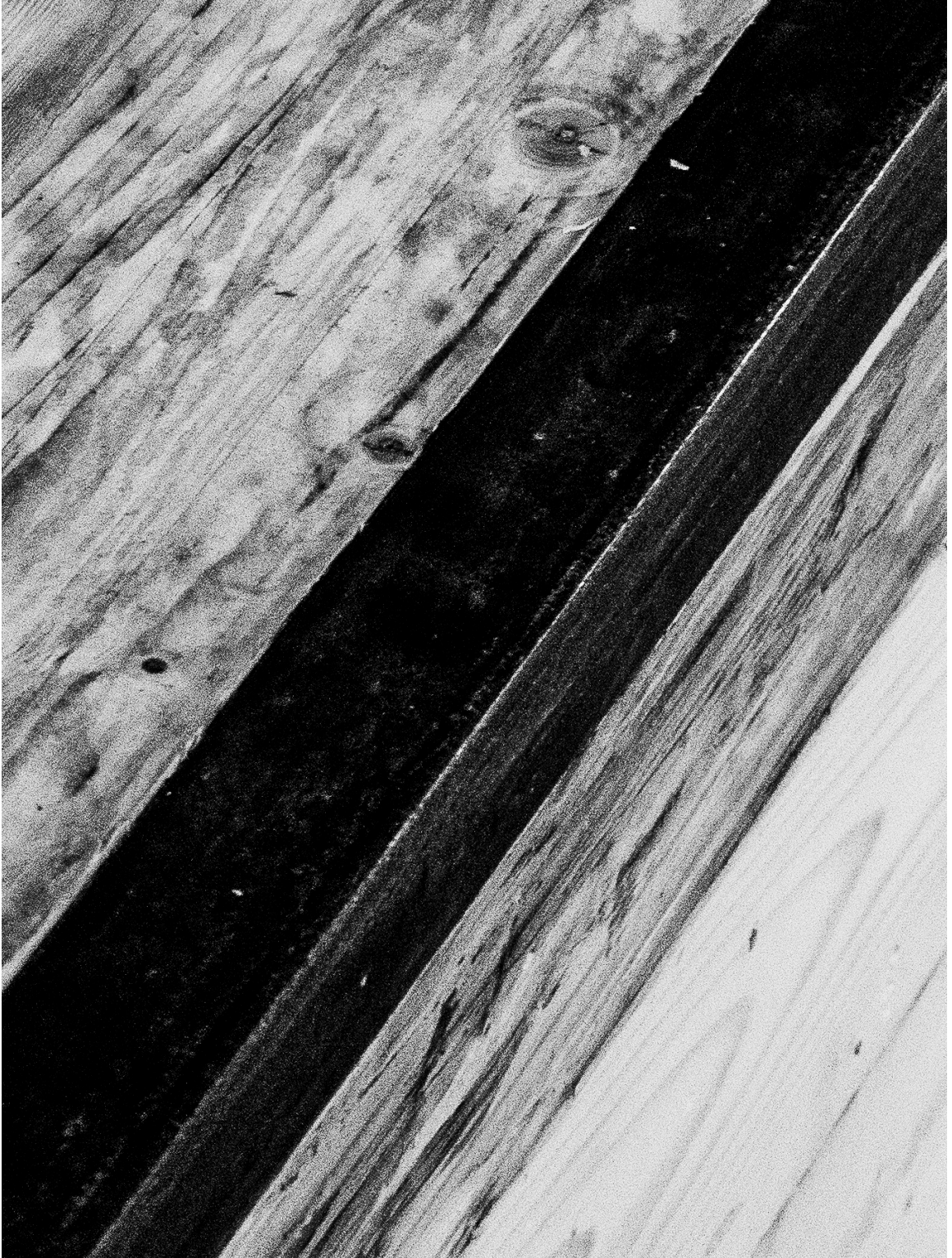

Traces: marks of a kinetic process.



Traces: clues of movements past and future.

## References

- Allen, Peter Van. 2013. "Paine's Park with a Side of Bacon Becomes Reality." *Philadelphia Business Journal*. <https://www.bizjournals.com/philadelphia/print-edition/2013/05/24/paines-park-with-a-side-of-bacon.html>.
- Alv, Pontus. 2016. "Polar-Paris-Avant-Premiere Poster." Popskate. <http://www.popskate.com/wp-content/uploads/2016/02/polar-paris-avant-premiere.jpg>.
- Architecture49. 2023. "LeMarchant-St. Thomas Elementary School." <https://architecture49.com/en/portfolio/projects/halifax-south-peninsula-elementary-school/>.
- Arteinformado. 2017. "Zulmiro de Carvalho. Esculturas, Exposición, Escultura, May 2017." <https://www.arteinformatado.com/agenda/f/zulmiro-de-carvalho-esculturas-138930>.
- Atencio, Matthew, E. Missy Wright, Becky Beal, and Zánean McClain. 2019. "Urban Skateboarding, Social Enterprise Groups, and Community Capacity-Building in the San Francisco Bay Area." *Society and Leisure* 42, no.3: 432–49. <https://doi.org/10.1080/07053436.2019.1682251>.
- Beal, Becky, and Kristin Ebeling. 2019. "Can You Sell Out If You've Never Been in? The Olympics and Creating Spaces for Gender Inclusion in Skateboarding." In *Skateboarding Between Subculture and the Olympics: A Youth Culture under Pressure from Commercialization and Sportification*, edited by Veith Kilberth and Jürgen Schwier, 97-116. 1st ed. Bielefeld: transcript Verlag.
- BMCA (Bordeaux Museum of Contemporary Art). 2012. "Michael Majerus." <https://www.capc-bordeaux.fr/agenda/expositions/michel-majerus>.
- Borden, Iain. 1998. "Body Architecture." In *Occupying Architecture: Between the Architect and the User*, edited by Jonathan Hill, 111-125. London: Routledge.
- Borden, Iain. 2001. *The Unknown City: Contesting Architecture and Social Space: A Strangely Familiar Project*. Cambridge, Mass: MIT Press.
- Borden, Iain. 2019. *Skateboarding and the City: A Complete History*. 1st ed. London: Bloomsbury Visual Arts. <https://doi.org/10.5040/9781474208420>.
- Burger, Toby. 2018. "Baldy Full Pipe - Toby Burger's Pool Skateboarding Archives of Southern California." <https://tobyburger.com/portfolios/baldy-full-pipe>.
- Caro Tanco, Fernando. 2021. "When Bogotá Belongs to the Bicycles: How Ciclovía Has Shaped Colombia's Capital City - Velo." *Outside Magazine*. <https://velo.outsideonline.com/culture/when-bogota-belongs-to-the-bicycles-how-ciclovía-has-shaped-colombias-capital-city/>.

- Charnoski, Rick, and Coan B. Nichols. 2020. *Loveletter To LGBTQ+ | Jeff Grosso's Loveletters to Skateboarding*. Video. VANS. [https://www.youtube.com/watch?v=kqD4xfNwd6k&ab\\_channel=Vans](https://www.youtube.com/watch?v=kqD4xfNwd6k&ab_channel=Vans).
- Cheng, Diane Russo. 2022. *Nike SB | Skate Like a Girl | Transenders*. Video. Nike SB. [https://www.youtube.com/watch?v=Be\\_wn0EjzJQ&ab\\_channel=nikeskateboarding](https://www.youtube.com/watch?v=Be_wn0EjzJQ&ab_channel=nikeskateboarding).
- Dantzler, Prentiss A. 2021. "The Urban Process under Racial Capitalism: Race, Anti-Blackness, and Capital Accumulation." *Journal of Race, Ethnicity and the City* 2, no.2: 113–34. <https://doi.org/10.1080/26884674.2021.1934201>.
- Debord, Guy. 1957. "The Naked City: Illustration de l'hypothèse Des Plaques Tournantes En Psychogéographique". Yale University Library Online Exhibitions. <https://onlineexhibits.library.yale.edu/s/hogarth-topographies/item/17486#?c=&m=&s=&cv=&xywh=-301%2C-1%2C9076%2C5879>.
- Dedication2Skate Design Agency. 2019. "Play! Des Oeuvres à Skater Pour La Saison Culturelle de Bordeaux 2019." <https://www.dedication.website/projets/play-bordeaux-2019>.
- Deitch, Jeffrey. 2003. "Jeffrey Deitch Archive." <https://www.deitch.com/archive/deitch-projects/exhibitions/session-the-bowl>.
- Ellsworth, Jillian, and Kieran Leavitt. 2017. "Skateboarders in Halifax Are Fed up with a Lack of Clarity." *The Signal*, January 18, 2017. <https://signalhfx.ca/skateboarders-in-halifax-are-fed-up-with-a-lack-of-clarity/>.
- Fick, Brian. 2014. "ESPN Photo Portfolio Showcase - Brian Fick." <http://www.espn.com/gallery/9927350/image/7/peter-hewitt-skate-photographer-brian-fick-photo-portfolio>.
- FAA (Fine Art America). 2019. "Kazimir Malevich." 2019. <https://fineartamerica.com/featured/malevich111-kazimir-malevich-eloina-mannion.html>.
- Gabor, Clayton, Martin Fobes, Michael Minter, and Jeff Samaripa. 2019. *DC Shoes: Skate Urbanism Feat. Leo Valls*. Film. USA: DC Shoes. <https://www.youtube.com/watch?v=Uxfqak7LMFU>.
- Guillermoprieto, Alma. 2019. "Bogotá, Colombia's Ciclovía Bans Cars Every Sunday, and People Love It." *National Geographic*. <https://www.nationalgeographic.com/environment/article/bogota-colombia-ciclovía-bans-cars-on-roads-each-sunday>.
- HRM (Halifax Regional Municipality). 2021a. "Halifax Integrated Mobility Plan." <https://www.halifax.ca/about-halifax/regional-community-planning/transportation-planning>.

- . 2021b. “Regional Plan Theme 5: Social Planning for Community Well-being.” [https://www.shapeyourcityhalifax.ca/regional-plan/news\\_feed/updates#:~:text=Theme%205%3A%20Social%20Planning%20for%20Community%20Well%2DBeing&text=Creating%3A%20the%20Office%20of%20Diversity,Alliance%2C%20Housing%20and%20Homelessness%20Partnership.](https://www.shapeyourcityhalifax.ca/regional-plan/news_feed/updates#:~:text=Theme%205%3A%20Social%20Planning%20for%20Community%20Well%2DBeing&text=Creating%3A%20the%20Office%20of%20Diversity,Alliance%2C%20Housing%20and%20Homelessness%20Partnership.)
- . 2022. “Map 1 - Urban Structure Designations.” <https://www.halifax.ca/about-halifax/regional-community-planning/community-plan-areas/regional-centre-plan-area>
- Hammond, Stuart. 2016. “Spike Jonze Skates against the Grain.” *Dazed Magazine*. [https://www.dazeddigital.com/artsandculture/article/30928/1/spike-jonze-skates-against-the-grain.](https://www.dazeddigital.com/artsandculture/article/30928/1/spike-jonze-skates-against-the-grain)
- Hayden, Dolores. 1980. “What Would a Non-Sexist City Be Like? Speculations on Housing, Urban Design, and Human Work.” *Signs* 5, no. 3: 170-87. <https://www.jstor.org/stable/3173814?seq=1&cid=pdf->.
- Hevia, José. 2020. “Barcelona Born Skateplaza — Skate Architects.” [http://www.skatearchitects.com/barcelona-skateplaza-born-ciudadella-ciutat-vella.](http://www.skatearchitects.com/barcelona-skateplaza-born-ciudadella-ciutat-vella)
- Higai, Yoshiro. 2018. “Skateboarding Calligraphy ‘Freehand’ by Takahiro Morita.” *LensCulture*. [https://www.lensculture.com/projects/725955-skateboarding-calligraphy-fre.](https://www.lensculture.com/projects/725955-skateboarding-calligraphy-fre)
- Holland, Hugh. 2019. *Silver. Skate. Seventies*. San Francisco: Chronicle Books.
- Irwin, Tim, and Steve Olpin. 2006. *Freedom Of Space: Skateboard Culture and the Public Space*. Film. Lehi: Fuel TV. [https://vimeo.com/197853696.](https://vimeo.com/197853696)
- Knabb, Ken. 1981. *Situationist International Anthology*. Berkeley, Calif: Bureau of Public Secrets.
- Kuby, Adam. 2006. “Wavewalk - Adam Kuby”. [https://www.adamkuby.com/public-works/walkwave.](https://www.adamkuby.com/public-works/walkwave)
- Lacoste. 2022. “Lacoste x Thrasher | Lacoste.” [https://www.lacoste.com/ca/en/lacoste/collections/now-trending/lacoste-x-thrasher/.](https://www.lacoste.com/ca/en/lacoste/collections/now-trending/lacoste-x-thrasher/)
- Larsen, Ted. 2023. “Work.” [https://tedlarsen.com/Work.](https://tedlarsen.com/Work)
- Lefebvre, Henri. 1974. *La Production de l’espace*. Paris: Éditions Anthropos.
- Lincoln, F.S. 2018. “In Search of Contoured Playground - The Noguchi Museum.” Special Collections Library, Pennsylvania State University Library. [https://www.noguchi.org/museum/exhibitions/view/in-search-of-contoured-playground/.](https://www.noguchi.org/museum/exhibitions/view/in-search-of-contoured-playground/)
- Michna, Ian, Alex Coles, and Greg Navarro. 2022. “The Story Behind Art Dealer Jeffrey Deitch’s Wooden Bowl”. Video. New York: Jenkem Magazine. [https://www.youtube.com/watch?v=9DmFQ\\_dg9XQ&t=222s&ab\\_channel=jenkemmag.](https://www.youtube.com/watch?v=9DmFQ_dg9XQ&t=222s&ab_channel=jenkemmag)

- Montero, Sergio. 2017. "Worlding Bogota's Ciclovía: From Urban Experiment to International 'Best Practice.'" *Latin American Perspectives* 44, no. 2: 111–31. <http://www.jstor.org.ezproxy.library.dal.ca/stable/26178813>.
- Newline Skateparks. 2023. "Cloverdale Covered Youth Park - New Line Skateparks." <https://www.newlineskateparks.com/project/cloverdale-covered-youth-park/>.
- O'Connor, Paul. 2017. "Beyond the Youth Culture: Understanding Middle-Aged Skateboarders through Temporal Capital." *International Review for the Sociology of Sport* 53, no.8: 924–43. <https://doi.org/10.1177/1012690217691780>.
- Province of Nova Scotia. 2022. "Motor Vehicle Act." <https://novascotia.ca/just/regulations/rxam-z.htm>.
- Santa Cruz. 2023. "Santa Cruz Skateboards | Skateboard Decks, Completes, Cruisers & Longboards." <https://santacruzskateboards.com/skate>.
- Schaeffer, Cesar. 2022. "Drop in." In *Riding Modern Art*, edited by Raphael Zarka, 20-21. Montreuil: Éditions B42.
- Schwinghammer, Stefan. 2015. "Raphaël Zarka about Skating Sculptures." *Solo Skateboard Magazine*. <https://www.soloskatemag.com/raphael-zarka-about-skating-sculptures>.
- Skateistan. 2023. "Phnom Penh." <https://skateistan.org/location/cambodia>.
- Stevens J. 2023. "I came out as trans about 6 months after I started skateboarding. I honestly believe skateboarding is what taught me the courage to do it". [comment on the video "Nike SB | Skate Like a Girl | Transenders"]. YouTube. [https://www.youtube.com/watch?v=Be\\_wn0EjzJQ&t=4s&ab\\_channel=nikeskateboarding](https://www.youtube.com/watch?v=Be_wn0EjzJQ&t=4s&ab_channel=nikeskateboarding)
- TGSI (Tactile Ground Surface Indicators). 2023. "Skateboard Deterrents Australia Wide, Anti Skate Fitting, Skate Stops, Skate Board Blockers. Stainless Steel and Polyurethane Anti Skate Fittings". [https://www.tactileindicators.net/skateboard\\_deterrents.htm](https://www.tactileindicators.net/skateboard_deterrents.htm).
- Theories of Atlantis. 2014. "Pontus Alv." Blog. <https://www.theoriesofatlantis.com/blogs/interviews/pontus-alv>.
- Thrasher Magazine. 2022. "The Thrasher Mag Archives." <https://www.thrasher magazine.com/component/coverarchive/covers?Itemid=>.
- . 2023. "Max Palmer's 'Spiked Off' Spitfire Part". Video. [https://www.youtube.com/watch?v=sjVgn9eHOo&ab\\_channel=ThrasherMagazine](https://www.youtube.com/watch?v=sjVgn9eHOo&ab_channel=ThrasherMagazine).
- UNHBUF (UN Habitat for a Better Urban Future). 2022. "World Cities Report 2022: Envisaging the Future of Cities." <https://unhabitat.org/world-cities-report-2022-envisaging-the-future-of-cities>.



VDZ+A (Van Der Zalm + Associates), Vancouver Park Board Staff Team, Vancouver Park Board Commissioners, S.A.G.E (Skateboard Advisory Group of Engagement, Skatepark Oversight Team (S.P.O.T.), City of Vancouver, and Newline Skateparks. 2022. "Vancouver City Skate - Skateboard Amenity Strategy." <https://vancouver.ca/parks-recreation-culture/skateboard-amenities-strategy.aspx>.

Verret, M., & R. Zarka. 2016. "Raphael Zarka - Portfolio." <https://raphaelzarka.com/>.

White, Alex, and Kristin Ebeling. 2021. "Honor Roll 2020: The Top Women and Non-Traditional Skaters of the Year." *Thrasher Magazine*. <https://www.thrasher magazine.com/articles/honor-roll-2020-the-top-women-and-non-traditional-skaters-of-the-year/>.

Wohnseifer, Johannes. 1998. "Backworlds/Forwards." <https://www.wohnseifer.com/archive/1998/backworldsforwards-with-mark-gonzales/4/>.