

# **Dynamic Architecture in the Canadian Arctic**

by

Kevin T. Dolphin

Submitted in partial fulfilment of the requirements  
for the degree of Master of Architecture

at

Dalhousie University  
Halifax, Nova Scotia  
March 2019

© Copyright by Kevin T. Dolphin, 2019

# CONTENTS

Abstract .....	iii
Acknowledgements .....	iv
Chapter 1: Introduction .....	1
Thesis Question.....	3
Chapter 2: Arctic Traffic .....	6
Arctic Climate .....	6
Marine Traffic.....	6
Quantifying Traffic.....	8
Air Traffic.....	12
Impact of Increased Traffic .....	12
Environmental Impact.....	12
Cultural Impact.....	13
Economical Impact .....	14
Safety Factor .....	15
Governmental Impact .....	18
Resulting Complexity.....	18
Chapter 3: Canadian Response .....	19
Current Situation.....	19
Intervention Opportunity .....	23
Chapter 4: Arctic Specific Design .....	24
Expedition and Architectural Strategies.....	24
Arctic Building Generations .....	24
Realities of Northern Construction.....	30
Chapter 5: Design Proposal .....	32
Situating + Seasonality.....	32
Building Program .....	37
Construction Assembly .....	44
Dynamic Elements.....	46
Chapter 6: Conclusion .....	64
Bibliography.....	66

## **ABSTRACT**

This thesis investigates changing conditions in the Canadian Arctic. Reduced yearly sea ice extent due to anthropogenic global climate change has spurred a significant increase in marine traffic within the Canadian Arctic archipelago. Simultaneously, aerospace developments have resulted in more trans-polar flights connecting Europe and Asia to North America. Increased activity in the Arctic poses both opportunity and risk to the people and environment.

This thesis proposes seasonally responsive infrastructure in Cambridge Bay, a community located centrally in the Canadian North. The infrastructure provides a platform for search and rescue services and environmental disaster response while actively engaging the local population. It also proposes methods for increasing operational and resource autonomy from the south. The North has a strong climatic seasonality and regional implications that add spacial and temporal complexity/considerations to construction projects. This thesis strives to adapt to and not fight against the realities of the Canadian Arctic.

## **ACKNOWLEDGEMENTS**

This has been a good bit of fun.

To Team Steve (Steve Parcell and Steve Mannell): big thanks for patiently and enthusiastically encouraging me to think about it again.

To my good friends that I came with, and those I met along the way: you have made my time here a complete slice.

To my family: after a decade of pursuing post-secondary education in architecture you never once (impatiently) asked if I was done yet, or doubted my intentions. Your support has been characteristically monumental.

And to Emily: I can help with rent now.

## CHAPTER 1: INTRODUCTION

The Canadian Arctic is a significant distance from the rest of Canada, both physically and mentally. The three northern territories account for 40% of the country's landmass and its complex archipelago has 162,000 km of coastline.<sup>1</sup> The three territories are home to only 113,604 Canadians, only 0.3% of the total population of the country.<sup>2</sup> It's uncommon for 'Southerners' to visit the Canadian Arctic, as travelling can take several flights and be very costly. From Toronto, Ontario it is both cheaper and faster to fly to Cape Town, South Africa than Cambridge Bay, Nunavut.<sup>3</sup> In addition to challenges of access, the lack of easily obtainable natural resources, extreme and unpredictable climatic conditions, and small scattered population round out the list of reasons that the Canadian North has remained relatively quiet and underdeveloped. The Arctic is the focus of a new burst of activity, however, ironically one fueled primarily not by what lies in it, but beyond it.

The written history of the Canadian Arctic began in the late 15th century by Europeans navigating through Inuit territory. Prior to their intrusion, small, isolated nomadic groups of Inuit moved through the Arctic, following temporal food sources and adapting their equipment and lifestyle to the shifting seasonality. European exploration peaked in 1906 with Roald Amundsen's complete maritime transit of the

---

1 William R. Morrison, *Canadian Arctic Sovereignty*, The Canadian Encyclopedia, last modified May 29, 2018, <https://www.thecanadianencyclopedia.ca/en/article/arctic-sovereignty>.

2 Statistics Canada, *Population, Dwellings and Households of Canada, Provinces and Territories, 2016 Census* (Statistics Canada Catalogue no. 98-400-X2016013, Ottawa, Ontario), May 3, 2017.

3 Listed information on Kayak.com, accessed March 3, 2019.

Northwest Passage.<sup>4</sup> A sea route connecting the Atlantic and Pacific was coveted for centuries; however, the concept lost interest after recognizing the difficulty in accessing the region due to its inundation with sea ice.

In modern times climate externalities have changed the tone of the region. Global climate change has had a major impact on Arctic temperatures and specifically Arctic sea ice. The extent of summer sea ice within the Arctic Circle has shrunk by over 49% since 1979,<sup>5</sup> and with it has come a renewed interest in the Northwest Passage functioning as a major marine route and zone. The number of vessels travelling through the Passage is increasing and is projected to continue to grow as the ice retreats further.<sup>6</sup> Air traffic above the Arctic has increased dramatically following the dissolution of the Soviet Union in 1991 and the passing of legislation to permit twin engine planes to travel greater distances.<sup>7</sup> Over 3 million passengers fly on trans-polar Arctic routes every year, with most of these flights passing directly over Canadian Arctic territory. It would be a Canadian responsibility if they were to require assistance.

Increased marine and air traffic will over-exceed Canada's limited Arctic capacity, severely hindering the ability to provide essential services and putting locals, visitors, and the

---

4 Encyclopædia Britannica, *Roald Amundsen*, last modified July 12, 2018, <https://www.britannica.com/biography/Roald-Amundsen>.

5 NSIDC / NASA, *Arctic Sea Ice Minimum*, last modified January 1, 2018, <https://climate.nasa.gov/vital-signs/arctic-sea-ice/>.

6 The Pew Charitable Trusts, *The Integrated Arctic Corridors Framework* (2016), 31.

7 John Croft, "US FAA to end ETOPS range restrictions for qualified aircraft," *Flight Global*, January 9, 2007, <https://www.flightglobal.com/news/articles/us-faa-to-end-etops-range-restrictions-for-qualified-aircraft-211460/>.

environment at great risk.<sup>8</sup> Canada has begun to construct several polar class ships but lacks built infrastructure within the Canadian Arctic from which to provide essential support and services. Travelling to several locations within the Arctic Circle on scholarship-funded research enabled me to observe Arctic specific design and construction.<sup>9</sup> Discussions with professionals from various disciplines also revealed the challenges associated with building in remote polar regions. The infrastructure must be capable of delivering services while acknowledging and adapting to specific Northern conditions and restrictions.

### **Thesis Question**

How can architecture address risks associated with transportation in the Canadian Arctic while acknowledging Northern geographical and climatic complexities?

---

8 The Pew Charitable Trusts, *The Integrated Arctic Corridors Framework*, 24.

9 John D. Watson Memorial Travel Research Scholarship to Kotzebue, Alaska; Longyearbyen, Norway; and Cambridge Bay, Canada. (May + August, 2018)

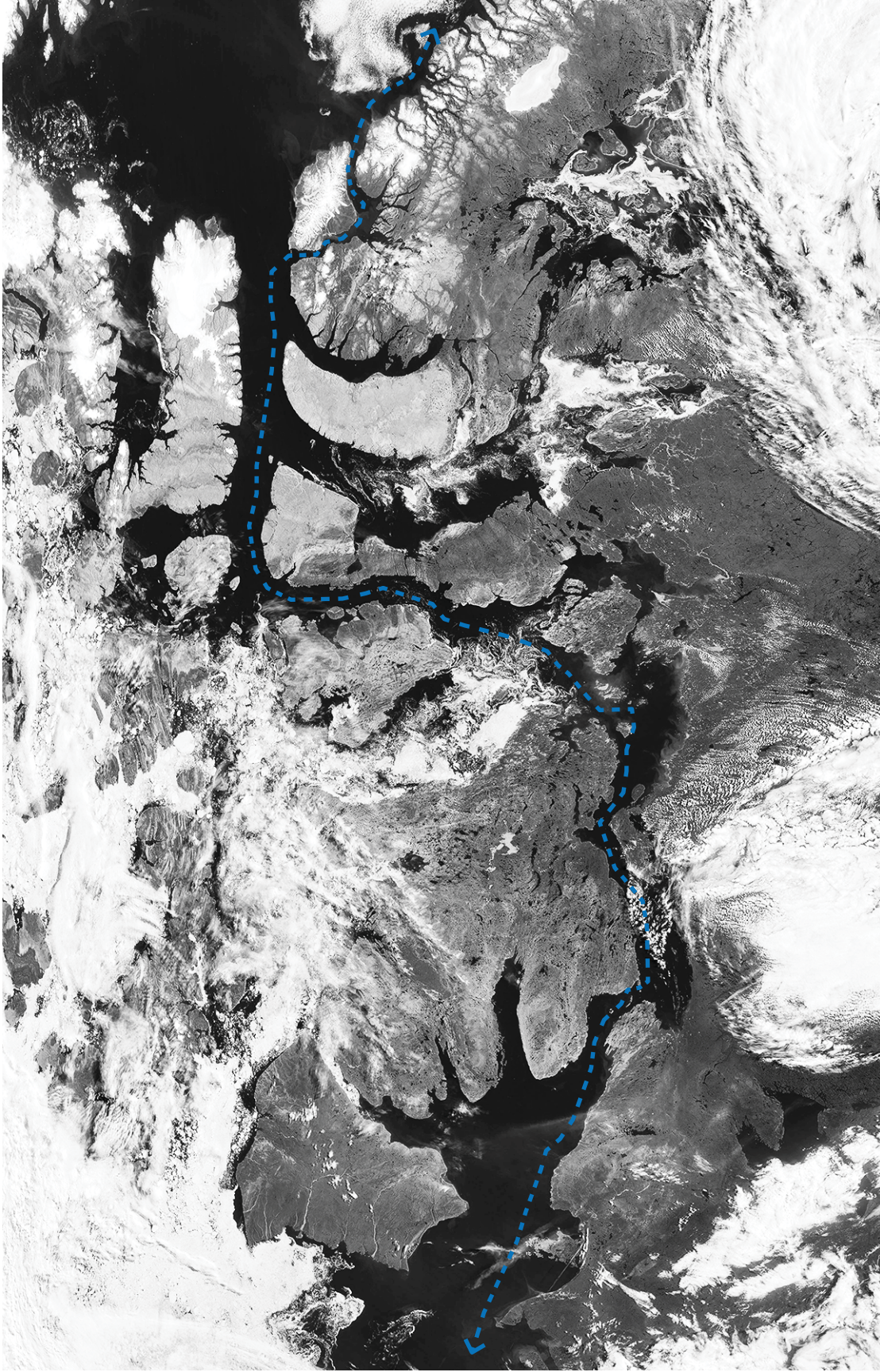

The ice-free Northwest Passage, October 2016; satellite photo from Jeff Schmaltz / NASA Earth Observatory



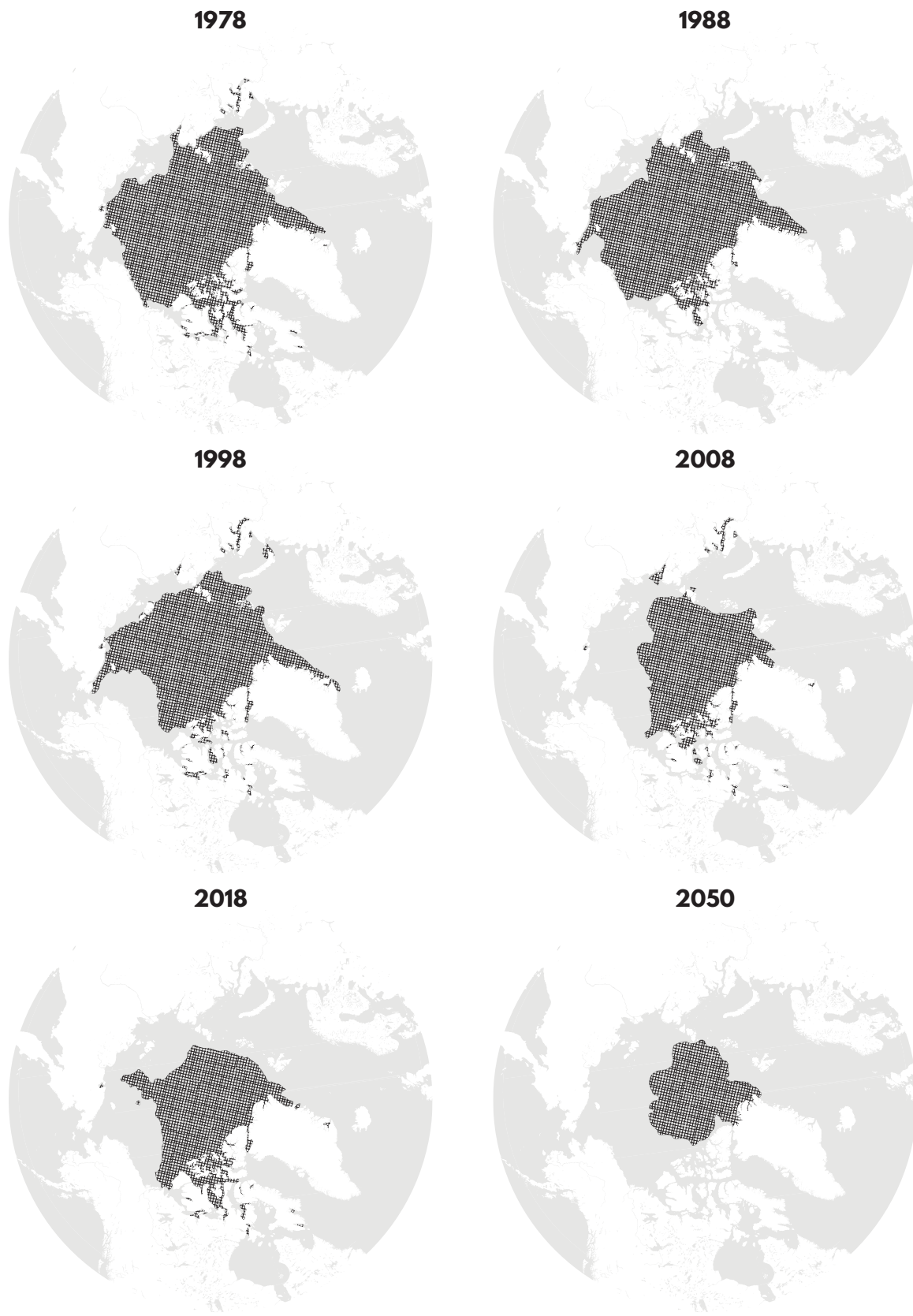

The recorded and projected summer extent of sea ice in from 1978 to 2050; data from National Snow and Ice Data Centre "Sea Ice Index"

## CHAPTER 2: ARCTIC TRAFFIC

### Arctic Climate

The Arctic has quietly been changing over the past several generations, far away from the majority of Canadians. Warming temperatures caused by anthropogenic climate change are having an effect on the region and changing this dramatic landscape.<sup>10,11</sup> For a number of reasons the Arctic is experiencing warming nearly two times faster than the global average.<sup>12</sup> The most spectacular change has been the effect of this new climate on sea ice. Arctic sea ice extent has been on the decline for decades. Areas that were once difficult to get to or through because of sea ice have become accessible for longer periods of time. Simulations in the Arctic Council's Arctic Marine Shipping Assessment 2009 annual report predict a summer ice-free Arctic Ocean before mid-century.<sup>13</sup> This has already had a number of localized effects on the region, including changing migration patterns for animals and reduction of mobility for the Inuit.<sup>14</sup> Most significantly, retreating sea ice is opening up the Northwest Passage to increased marine traffic.

### Marine Traffic

Marine access to and through the Northwest Passage was

---

10 Susan J. Hassol, *Impacts of a Warming Arctic: Arctic Climate Impact Assessment* (Cambridge: Cambridge University Press, 2004), 8.

11 Arctic Monitoring and Assessment Programme (AMAP), *Arctic Climate Issues 2011: Changes in Arctic Snow, Water, Ice and Permafrost* (Oslo: Arctic Monitoring and Assessment Programme, 2012), v.

12 WWF, *Arctic Climate Change*, Accessed January 3, 2019. <https://arcticwwf.org/work/climate/>.

13 Arctic Council, *Arctic Marine Shipping Assessment 2009 Report* (PAME, 2009), 35.

14 Hassol, *Impacts of a Warming Arctic*, 94-7.

the dream of many explorers, scientists, politicians, and economists for centuries. The dream was largely put aside in the early 20th century when the Passage was deemed too inaccessible to be useful; however, the Arctic remains to this day highly reliant on marine transportation. Northern Canadian populations are dispersed thinly throughout island chains and remote continental shorelines, making air transport expensive and a year-round road network impossible. Twentieth-century marine traffic was comprised almost exclusively of government research vessels and icebreakers, the odd resource extracting bulk carrier, and a few community resupply ships that would visit a few times each year. The ships were primarily of Canadian origin and their numbers were small enough not to warrant an extensive investment in marine infrastructure within the archipelago. That attitude has changed with the reduction of sea ice and the resulting longer shipping seasons.<sup>15</sup> Over the last decade, vessel kilometres have increased dramatically and vessels with different purposes and intentions have become increasingly common.<sup>16</sup> Cruise ships and private pleasure boats are visiting arctic communities in larger numbers, with some navigating the entirety of the Passage. International companies have also expressed interest in using the Northwest Passage to ship goods from Asia to the Atlantic Seaboard and Europe as an alternative to the Panama Canal. To understand the impact of the current and projected marine traffic it is beneficial to understand which vessel types are sailing in the Arctic region.

---

15 James Parsons, *Benchmarking of Best Practices for Arctic Shipping* (WWF, 2012), 7.

16 Jackie Dawson, Larissa Pizzolato, Stephen E.L. Howell, Luke Copland and Margareet E. Johnston, "Temporal and Spatial Patterns of Ship Traffic in the Canadian Arctic from 1990 to 2015," *Arctic* 71, no. 1 (2018): 19.

## Quantifying Traffic

Projections for future marine traffic voyages mirror the projections for sea ice extent, increasing significantly towards mid-century. The present and projected future marine traffic consists of a variety of vessel types carrying a variety of passengers and cargo with a variety of intentions. To develop a response to an increase in traffic it is imperative to quantify and understand the variety of vessels and service infrastructure requirements for each type.

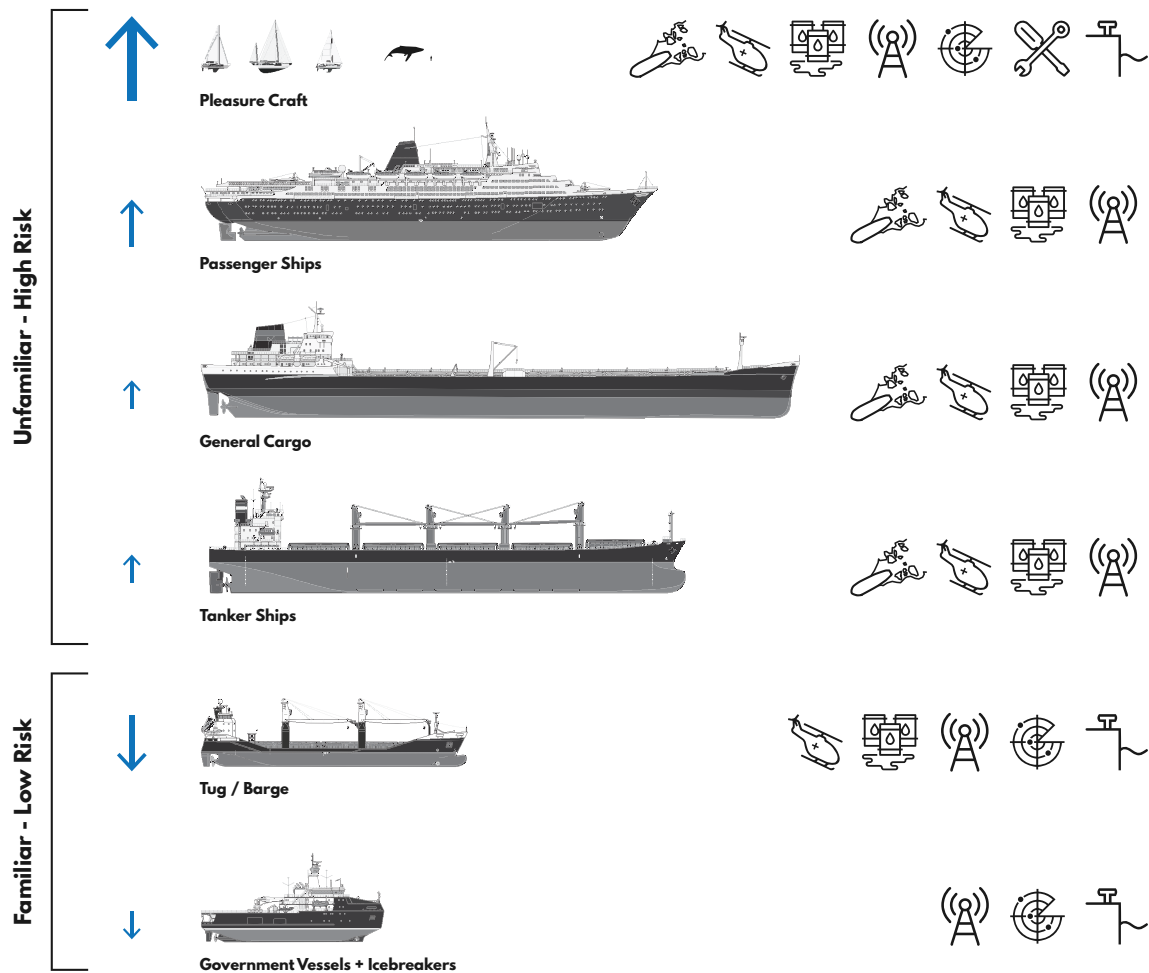

Vessel types within the Kitikmeot Region and services required; data from Jackie Dawson et al., *Temporal and Spatial Patterns of Ship Traffic in the Canadian Arctic from 1990 to 2015*

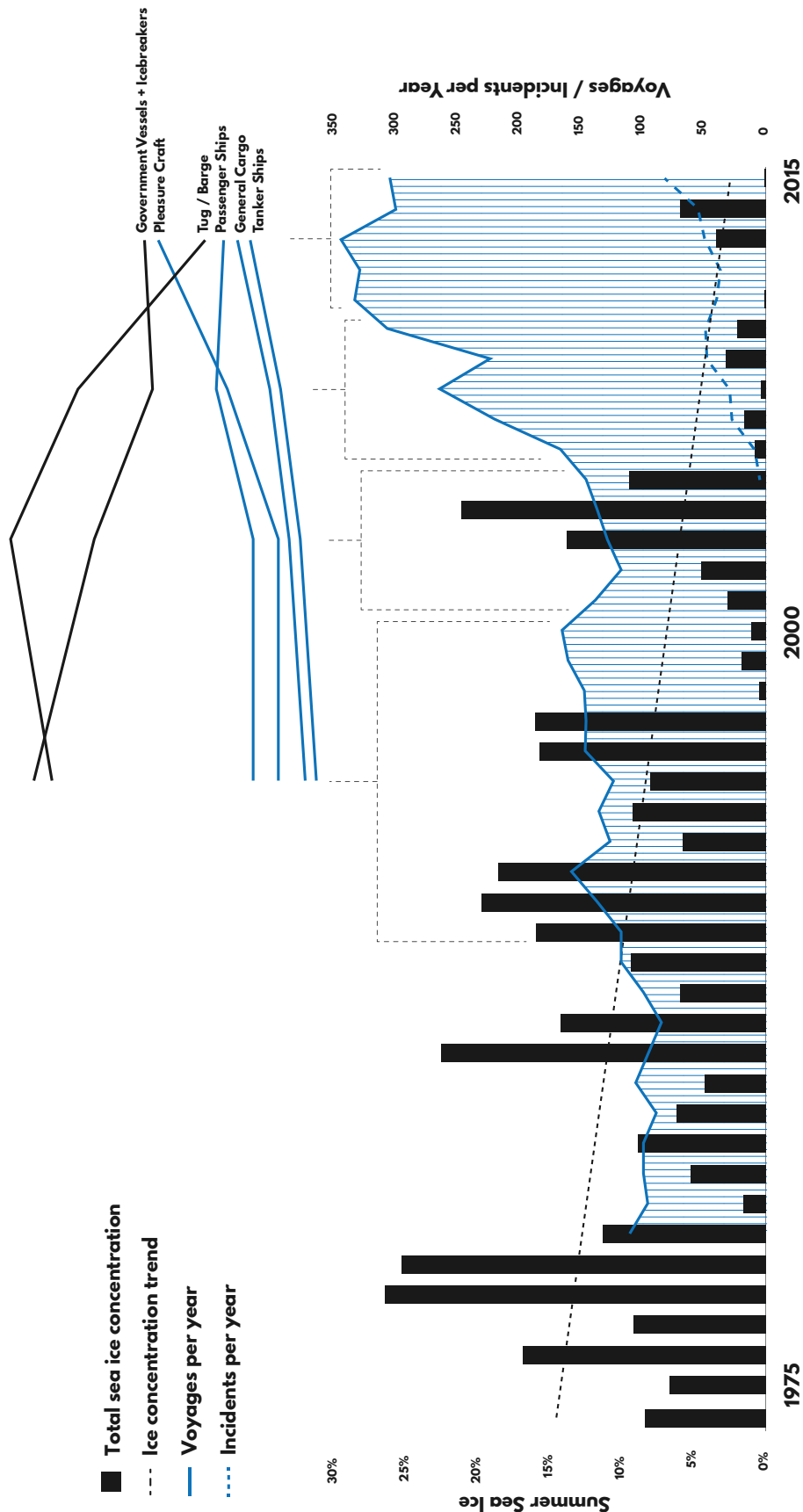

Graphing central Arctic sea ice concentration against marine traffic and incident rates, noting a trending increase in vessel types that are unfamiliar with Arctic waters; data from Jackie Dawson et al., *Temporal and Spatial Patterns of Ship Traffic in the Canadian Arctic from 1990 to 2015*; The Pew Charitable Trusts, *The Integrated Arctic Corridors Framework*

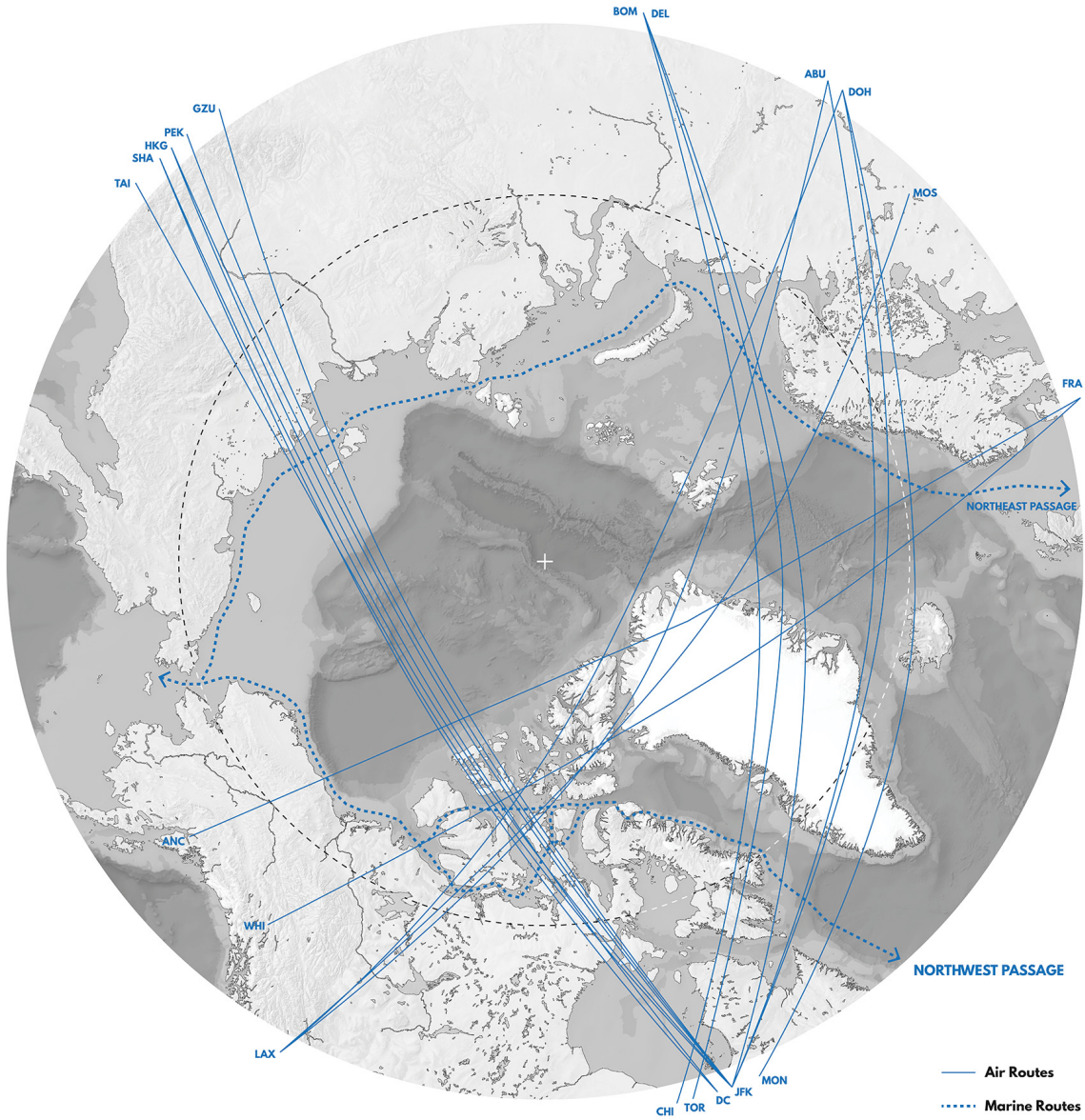

Marine and air traffic within the Canadian Arctic; data from The Pew Charitable Trusts, *The Integrated Arctic Corridors Framework*; FlightAware, "Flight Search"

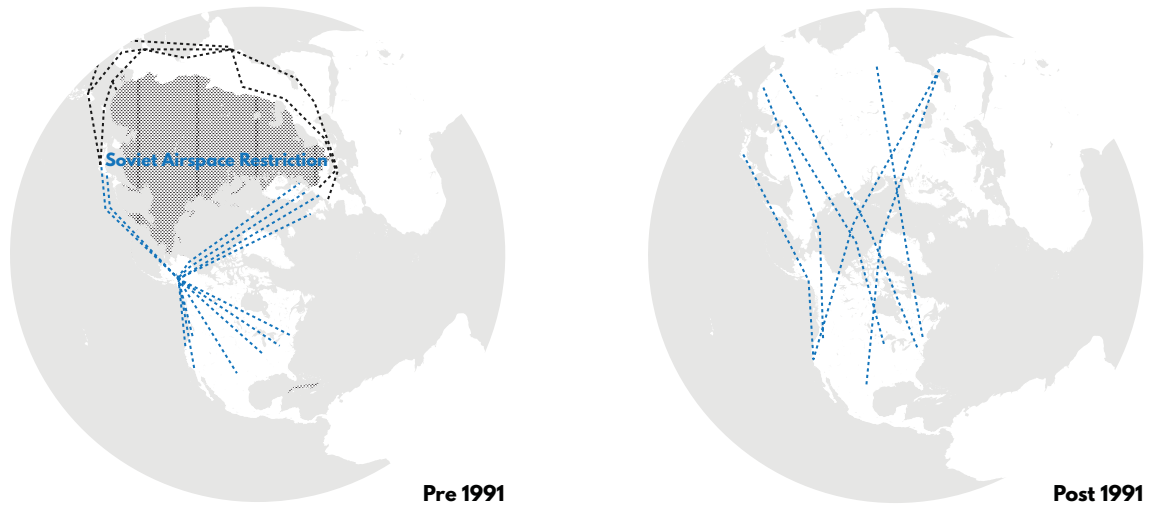

General arrangement of air traffic pre- and post-1991; data from Ingegneria dei Sistemi, *Canada-Italy: Arctic Science and Technology Collaboration Workshop*, 4

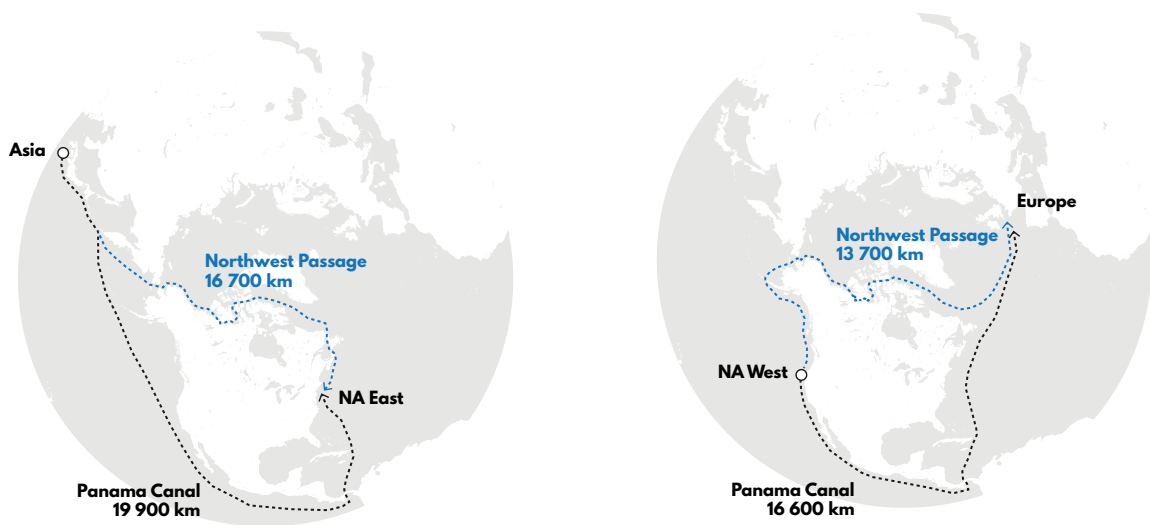

Trans-Arctic Shipping Routes, savings using the Passage are significant; data from A. Atkisson, T. Arnbom, C. Tesar, A. Christensen, *Getting It Right in a New Ocean: Bringing Sustainable Blue Economy Principles to the Arctic* (Summary). (WWF Arctic Programme, 2018), 10

## **Air Traffic**

Since 2003 there has been an increase by over 1100% in flights over the Canadian Arctic.<sup>17</sup>

Similar to marine traffic, polar air traffic in the last decade has experienced significant increase. After the dissolution of the Soviet Union in 1991 the Russian Federation opened its previously restricted airspace to international flight traffic. This opened new air routes connecting Asia and the Middle East to North America. In 2000, the first year of regular cross-polar flights, 402 commercial flights flew above 78 degrees north. That number increased to 8,527 in 2009<sup>18</sup> and again to 11,214 in 2012<sup>19</sup>, equating to approximately 3.3 million air passengers per year above the Arctic. Air traffic will not require the same support as marine traffic, but will still need specific services to be available year round to address emergency situations.

## **Impact of Increased Traffic**

An increase of marine and air traffic will have significant effect on the complex and fragile network that exists in the Canadian Arctic. There will be environmental, cultural, economic, safety, and governmental impacts. Because the traffic has such variety and complexity the resulting impacts have both positive and negative conditions.

---

17 Dylan Clark, excerpt from opening statement in senate testimony to the Senate Committee on Fisheries and Oceans, February 13, 2018, 2.

18 Hok K. Ng, Banavar Sridhar, Shon Grabbe, Neil Chen, "Cross-Polar Aircraft Trajectory Optimization and the Potential Climate Impact," (Innovations in Automotive and Aerospace Assembly, 2011), 1.

19 Mia Bennett, "MH 370: What if it were to happen in the Arctic?," last modified March 25, 2014, <https://www.cryopolitics.com/2014/03/25/mh370-what-if-it-were-to-happen-in-the-arctic/>.



## Environmental Impact

The Arctic environment is harsh, but delicate and impressionable. Increased traffic generates noise pollution and air pollution; foreign ballast and waste can introduce invasive species; and an inexperienced crew in a harsh environment risk collisions and spills. In the event of a disaster, fuels and other foreign materials can be deposited on the land and in the water. These environmental stresses have a negative impact on Arctic ecosystems that include several species of marine mammals, fish numbers and diversity, and bird populations. Not remediating these sites quickly can cause irreversible damage. Northern ecosystems stand to be threatened by the unmediated encroachment of traffic into regions that are unprepared and under-equipped to accommodate it safely.

## Cultural Impact

Increased activity has the potential of bringing employment and economical activity. When activity is unmediated and unfettered, the local people have little control over interactions with transient groups visiting their town, which undermines community agency further. Likewise, when semi-transient populations are not integrated well, this can lead to a lack of communication, a reduced sense of belonging, and social disruption. This is particularly noticeable when small communities see their populations rapidly increase because of opportunistic migrants<sup>20</sup> who are generally hired for a specialized position, most often in construction, sciences, or government. A two-week-on, two-week-off schedule can disconnect that group of people from the permanent



Seal skinning competition as part of Toonik Tyme, an annual celebration of Inuit traditions and return to spring, Iqaluit, 2016

---

<sup>20</sup> Arctic Council, *Arctic Marine Shipping Assessment 2009 Report* (Akureyri: Protection of the Arctic Marine Environment, 2009), 123.

population and erode the strength of the community. Northerners traditionally have pleasant exchanges with strangers, something noticeably absent with newcomers to an area.<sup>21</sup> The cultural divide widens when transient and permanent populations do not have opportunities to mix. The impact of increased shipping on the environment also has a direct impact on Indigenous traditional knowledge and skills. Traffic brings the possibility of endemic or semi-endemic flora or fauna risking endangerment or extinction in the case of an oil spill. Arctic ecology plays a central role in Inuit culture, so ecological loss would certainly have cultural impacts. A changing hydrosphere and cryosphere will change the environment in which traditional knowledge thrives, forcing it to adapt or become less applicable.<sup>22</sup>

### **Economical Impact**

Increases in tourism, mining, oil exploration, and goods transportation will affect the local economy. Traffic to an area will result in more indirect opportunities to sell local goods to outside markets, and several direct opportunities throughout the shipping season to sell to tourists. There will continue to be interest in the extraction of raw materials from the Arctic following the retreat of sea ice: primarily oil, gas, and minerals. Scott Miner, the Chief Investment Officer of Guggenheim Partners, a global investment company, has called the Arctic “the best investment opportunity of the last 12,000 years.”<sup>23</sup> More marine traffic will also lower



Seal meat is distributed to locals and visitors after the competition, Iqaluit, 2016

21 Northerners wave to one another when passing each other in town. Newcomers are often unaccustomed to this practice and do not return the greeting. Noted in discussion with residents of Kotzebue, Alaska and Cambridge Bay, Nunavut.

22 AMAP, *Arctic Climate Issues 2011*, 77.

23 A. Atkisson, T. Arnbom, C. Tesar, A. Christensen, *Getting It Right in a New Ocean*, 5.

the cost of importing goods to the community by increasing the frequency of sealifts,<sup>24</sup> while increased resource development can provide employment and income for Arctic residents.<sup>25</sup> People whose livelihoods are based on a living resource (plants and animals) are likely to struggle more with native species being directly affected by ship traffic. Most new major economic opportunities such as shipping, resource extraction and cruise tourism are more likely to benefit companies and people based outside the Arctic.<sup>26</sup> Most importantly, an appropriate response to increased traffic will generate many jobs that can only be filled by local people due to their intimate experience of working on the land. Northern communities can benefit from increased traffic by offering critical services that are currently absent<sup>27</sup> and charging fees for supporting those services.

### Safety Factor

Conditions in the Arctic are harsh and unpredictable at the best of times; unprepared individuals and groups travelling through the region may quickly find themselves in danger. Travelling on the ice around the freeze up and melting shoulder seasons (March and November) is common and can result in people and vehicles falling through the thin ice. A scarcity of supporting infrastructure limits search and rescue availability and disaster response capacity.<sup>28</sup> As activity increases, the number of incidents will likely



Snowmobiling across the melting ice, photograph by Peter Prokosch, Pond Inlet, 2013

24 A sealift is a semi-yearly delivery of goods that would be too expensive to move by air: bulk dry goods, fuel, vehicles, etc.

25 Arctic Council, *Arctic Marine Shipping Assessment 2009 Report*, 123.

26 AMAP, *Arctic Climate Issues 2011*, 77.

27 James Parsons, *Benchmarking of Best Practices for Arctic Shipping*, 20.

28 World Wildlife Foundation (WWF), *Arctic Shipping Fact Sheet 2013* (WWF, 2013), 1.

increase and the limited infrastructure will be stretched even thinner.<sup>29</sup> Hunter-gatherers will continue to access the land and navigate through ice conditions that may change rapidly, leading to being stranded on or crashing through the ice.<sup>30</sup> Marine accidents in the Canadian Arctic are usually due in part to the harsh weather and poor bathymetric surveys and navigational aids in the region. Although airlines do not plan to land in the Arctic during regular operation, trans-polar air traffic brings risks of its own. During an emergency situation an aircraft may be forced to land, or may crash. Survivors will require timely medical attention, and the surrounding environment will likely require remediation to prevent ecological damage. Although infrequent, air disasters have occurred in the Arctic Circle with loss of life, with survivors spending multiple days waiting for assistance.<sup>31</sup> In one case a crash caused the death of one passenger on impact, with three other passengers dying of hypothermia due to the 40-hour response time from southern search and rescue resources.<sup>32</sup> The circumpolar countries have delineated areas of responsibility in the Arctic Search and Rescue Agreement, for which Canada is the depositary. Canada is uniquely positioned in the Arctic and is responsible for the safety of a notoriously complex archipelago. Whether the incident occurs on land or ice, on or under water, or within Canada's airspace, it is Canada's responsibility to provide quick and effective assistance.

---

29 AMAP, *Arctic Climate Issues 2011*, 70.

30 Dylan Clark, excerpt from opening statement in senate testimony to the Senate Committee on Fisheries and Oceans, February 13, 2018, 2.

31 Sara Frizzell, "Remembering the Baffin Island plane crash that could have killed 26, 42 years ago today," *CBC*, November 3, 2017, <https://www.cbc.ca/news/canada/north/plane-crash-1975-nunavut-1.4385869>.

32 E.G. Lennox, "It's time... Search and Rescue IN the Arctic!," *FrontLine* 2, no. 5 (2005), <https://defence.frontline.online/magazine>.



The Arctic Search and Rescue Agreement delineates regions each country is responsible for; data from Arctic Portal Library, "Arctic Search and Rescue Delimitation Map"

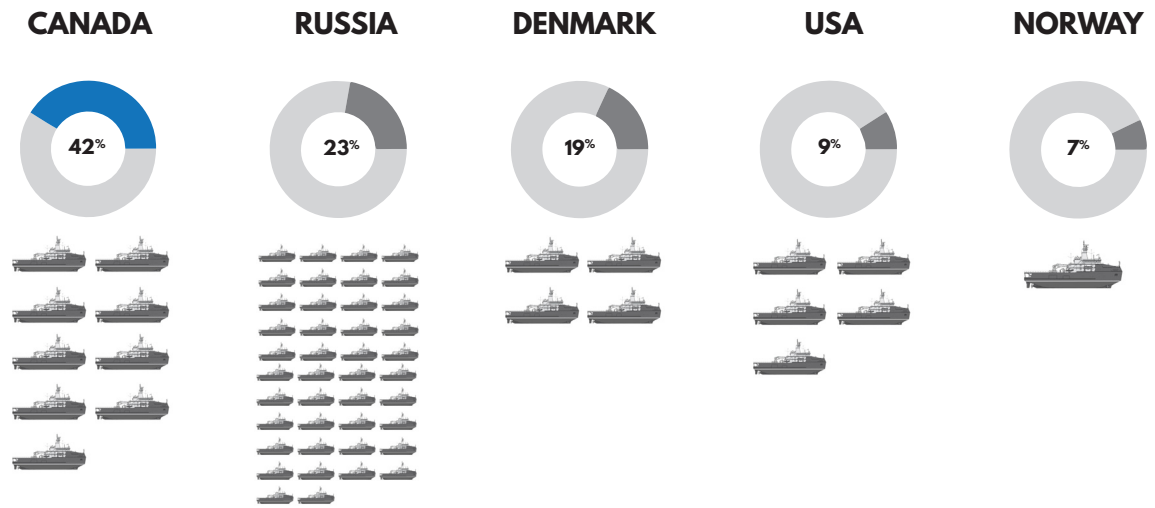

Percentage of Arctic coast line and number of icebreakers, data from The Pew Charitable Trusts, *The Integrated Arctic Corridors Framework*, 26

## **Governmental Impact**

There is international disagreement whether the Northwest Passage should be considered internal or international waters. Although it lies completely within Canadian territory, some nations dispute that Canada should have jurisdiction over the region.<sup>33</sup> If considered international waters all nations would have free transit through the Passage, restricting Canada's ability to enforce laws and eliminating the potential of charging vessels for access. Canada would be responsible for environmental regulations, smuggling laws, and search and rescue operations, but would not be able to re-coup costs from foreign vessels. By acting proactively to address the changing Arctic, Canada stands to strengthen its position to protect the region and provide proper services for vessels. In addition to global government interactions, additional traffic in the North stands to weaken local and territorial government if their voyages are unmediated. Shipping and tourism companies not bound by legislation give unprepared communities fewer options. By shifting operational power from Southern Canada to the people of the Arctic region, a greater level of autonomy and agency can be given to the people the vessel traffic and resulting legislation and development will affect.

## **Resulting Complexity**

An increase in marine and air traffic will have a ripple effect through the systems of the Canadian Arctic. It is a delicate and dense web of actors, where disruption to one part of the system will have effects on many other parts. Moreover, it is unprepared for the impacts that increased traffic will bring.

---

<sup>33</sup> Shelagh D. Grant, *Polar Imperative: a History of Arctic Sovereignty in North America* (Vancouver: Douglas & McIntyre, 2010), 449-450.

## CHAPTER 3: CANADIAN RESPONSE

Canada's Arctic Track Record: F. Of all polar countries, Canada has been the weakest in developing the potential of its Arctic regions and in responding to its full range of responsibilities there... It is abundantly clear that the overall Canadian presence in the area has fallen far short of circumpolar norms.<sup>34</sup>

### Current Situation

The current Canadian response to the demand of services in the Arctic is poor and has been that way for some time. Canada's Arctic history is fraught with episodes that highlight its inactivity and poor responses to the challenges faced in the North. The government of Canada has begun to direct legislation and increase funding to address the economy, culture, and safety of the region; however, it has not yet invested in physical infrastructure that is badly required. Examining its current state of services will define programs that can be addressed by the design proposal.

The issue that is frequently highlighted is the current lack of search and rescue services active in the region. As stated, numerous marine and air incidents have occurred throughout the Arctic and with increased traffic the potential for more will increase. The current Canadian search and rescue system is based on a hub system. There are three primary JRCC (Joint Rescue Command Centres) in Canada: Halifax, Trenton, and Victoria. Each JRCC is responsible for delivering search and rescue services to a specific section of Canada. When a call gets put out, one of the centres will coordinate a rescue plan based on distress location and weather conditions, and then perform that rescue with its equipment. The centres have been situated well to handle

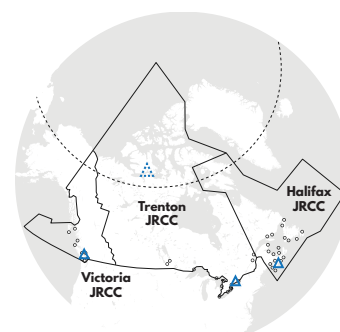

Locations of the three Canadian JRCC and their area of responsibility; data from Maj. J.G.R. Leroux, *The Arctic SAR Region: Frozen in Time*, 13

<sup>34</sup> Kenneth P. Coates et al., *Arctic Front: Defending Canada in the Far North* (Toronto: Thomas Allen Publishers, 2008), 191.





the majority of Canadian search and rescue situations that occur in southern latitudes but have not been sufficient when addressing the proportionally fewer northern incidents. The travel time for an aircraft from Trenton to the southernmost portion of the Canadian Arctic takes 6 hours in good weather and a rescue helicopter upwards of 14 hours, at which point SAR crews are typically already stressed and exhausted before the actual rescue effort has taken place. As put by E.G. Lennox:

It is simply not practical or realistic to launch an aircraft from southern Canada to effect an arctic search and rescue operation with an expectation of saving lives.<sup>35</sup>

Most of the solutions Canada has implemented for Arctic SAR have come in the form of localized program, not infrastructure. The system has leaned heavily on community volunteer groups to organize search parties using their own vehicles and equipment. The Canadian Rangers, a sub-component of the Canadian Armed Forces, provide assistance in domestic operations, perform surveillance patrols, and act as first responders in remote, isolated, and coastal communities in Canada.<sup>36</sup> Although this begins to tap into the location based knowledge of local people, high levels of stress result in volunteer burnout. There is government compensation for gas and oil, but little funding for new equipment and training.<sup>37</sup> The Canadian Rangers are given a rifle, 200 rounds of ammunition per year, and



Louis St. Laurent, the largest Canadian icebreaker; photograph by Mac Mackay, from *Shipfax*, 2011



CH-149 Cormorant, the larger SAR response helicopter used by the Canadian Coast Guard; photograph by John Davies, from *Wikipedia*, 2018

<sup>35</sup> E.G. Lennox, "It's time... Search and Rescue IN the Arctic!" *FrontLine* 2, no. 5 (2005), <https://defence.frontline.online/magazine>.

<sup>36</sup> "Canadian Rangers Frequently Asked Questions," Government of Canada, last modified August 14, 2018, <http://www.army-armee.forces.gc.ca/en/canadian-rangers/faq.page>.

<sup>37</sup> Dylan Clark, excerpt from opening statement in senate testimony to the Senate Committee on Fisheries and Oceans, February 13, 2018, 2.

reimbursement for wear and tear on their personal vehicles during official Canadian Ranger operations, as well as access to a first aid kit, a GPS device, and radio through their patrol groups<sup>38</sup>. There is also minimal formal training provided to communities, and when there is, it is noted that the training lacks “first aid training, emergency management training, training on how to work with RCMP, and practice conducting multi-agency responses”<sup>39</sup> to search and rescue incidents. The intent to utilize the knowledge of the local people more effectively in Northern programming has been wished for, but the resources to achieve that are still missing.<sup>40</sup> A number of government icebreaker vessels patrol the Arctic, acting as mobile response platforms; however, the assistance they provide only goes so far. They are limited to operating only in the summer months and, if they do carry a helicopter, it is relatively small with a short range as compared to the larger land based SAR specific CH-149 Cormorants. During the winter months the ships return south, leaving the Arctic responsibilities to southern aircraft and local volunteers. As mentioned earlier, many marine incidents are due to poor navigation and communication resources. Large portions of the Canadian Arctic are either poorly charted or have never been surveyed. One report quantifies it as such:

Only 1 percent of Canadian Arctic waters are adequately surveyed; 10 percent of nautical charts meet modern standards; 2 percent of Canada’s navigational aids are

---

38 “Canadian Rangers Frequently Asked Questions,” Government of Canada, last modified August 14, 2018, <http://www.army-armee.forces.gc.ca/en/canadian-rangers/faq.page>.

39 Dylan Clark, excerpt from opening statement in senate testimony to the Senate Committee on Fisheries and Oceans, February 13, 2018, 2.

40 Levon Sevunts, “Canadian Coast Guard wraps up busy Arctic season,” Eye on the Arctic, updated October 17, 2017, <http://www.rcinet.ca/eye-on-the-arctic/2017/10/17/canadian-coast-guard-wraps-up-busy-arctic-season/>.

deployed north of the Arctic Circle, and there are no deep-water ports.<sup>41</sup>

Ships that use old maps may strike submarine elements that are uncharted. Sea and ice conditions can quickly change, and without adequate monitoring and communications equipment, ships and locals may encounter conditions they were not expecting or prepared for. It has been noted that Canada's Arctic suffers from a lack of accurate and timely ice information and a method for how to distribute it.<sup>42</sup> There did exist a plan to construct a government naval facility in Nanisivik on Baffin Island, originally capable of acting as a home port for Arctic offshore patrol ships. The first plans included maintenance facilities, housing, a deepwater dock, and fuel storage; however, the project fell substantially behind schedule and over budget. The facility now supports only the fuel storage program, and is long past its operational date of 2014.<sup>43</sup> In summary, the Canadian North has programs implemented to prevent and assist in disaster situations, but these are primarily programmatic and lack built infrastructure.

## **Intervention Opportunity**

The introduction of infrastructure acting as a hub for Northern activity will make marine and air traffic safer for users, locals, and the environment.

---

41 The Pew Charitable Trusts, *The Integrated Arctic Corridors Framework*, 24.

42 Arctic Council, *Status on Implementation of the AMSA 2009 Report Recommendations* (Akureyri: Protection of the Arctic Marine Environment, 2013), 16.

43 CBC News, "B.C. firm wins design contract for Arctic naval port," last updated November 26, 2009, archived at <https://web.archive.org/web/20091130223348/http://www.cbc.ca/canada/north/story/2009/11/26/nanisivik-contract.html>.

## CHAPTER 4: ARCTIC SPECIFIC DESIGN

### Expedition and Architectural Strategies

I may add that, by means of our guns and nets, we obtained an ample supply of provisions last autumn, and my small party passed the winter in snow houses in comparative comfort, the skins of the deer shot affording abundant warm clothing and bedding.<sup>44</sup>

The failure or success of any given Arctic expedition can be anticipated by whether the expedition was designed for the Arctic - not just in terms of equipment and materials, but in strategy as well. The most prolific expedition successes in the Canadian Arctic took into consideration the climatic condition of the region and adapted to it. Explorers such as John Rae and Roald Amundsen noted the seasonality of the region and planned their movements on predictable weather conditions. They also sought out the knowledge of the Inuit for advice on Arctic travelling, nourishment, and shelter. Conversely, explorers like John Franklin chose to enter the Canadian Arctic without a sound Arctic strategy, resulting in the failure of the expedition and a significant loss of life.

### Arctic Building Generations

In the same way that expeditions have varying degrees of adapting to the Arctic, so does architecture. Architectural approaches to the Arctic have taken several forms throughout time. They can be categorized into five distinct generations, as defined by Norbert Schoenauer:<sup>45</sup>

---

44 Dr. John Rae to the Secretary of the Admiralty, July 29, 1854, in *Frank Leslie's New York Journal*, volumes 1-2 (1855), 40.

45 Norbert Schoenauer, "Shape and Orientation of New Buildings Design for Energy Conservation in the Sub-Arctic with Special Reference to Fermont," Economic Commission for Europe Committee on Housing, Building, and Planning (1977), 2-3.

### ***First generation***

The first generation of settlements was built and inhabited by indigenous people, the most recognizable examples being the igloo and the caribou skin tent. These shelters were temporary, moving locations through the year to follow the movement of food sources. They were also periodic, each being utilized for half the year. The buildings were small, compact, and in harmony with nature. Energy conservation was central to the lives of those dwelling, as reflected in the building itself. Both building types were erected quickly with minimal equipment and disappeared just as fast when the seasons changed.



The igloo; photograph by Aaron Vincent Elkaim, from *New York Times*, June, 2017

### ***Second generation***

The second generation came with the arrival of early Southern pioneers seeking the natural resources of a region. Buildings in this generation are characterized as being makeshift and haphazard. The Hudson's Bay Company deployed many trading posts throughout the territories to trade with the Indigenous people. Early mining camps and government outposts also shared in this typology. This generation represents the beginning of energy waste, although their impact is comparatively minimal due to their size.



The HBC trading post in Apex, Nunavut; photograph by Mark M. Miller, from "My Trip to Nunavut, Canada", August 2010

### ***Third generation***

As resource extraction intensified, population increased to match the demand. New construction began to have more permanence and settlements received more thought in their composition. The organization of towns was modelled on Southern suburban developments in an effort to make space relatable and attractive to temporary Southern



Arctic suburbanites; Cambridge Bay, August 2018

workers.<sup>46</sup> Buildings within the town were constructed to southern standards as well, continuing Generation Two's general disregard towards local climate and nature and questionable choice of building materials.

#### ***Fourth generation***

The fourth generation of settlements continued the insensitive suburban pattern, but replaced the traditionally dispersed institutional and commercial buildings of its town centre with a compact agglomeration of buildings. The “new town centre” became a cluster of community facilities linked by an internal and climatically-controlled mall. Human comfort rather than energy conservation was the motivating force.

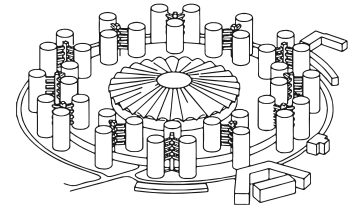

Frobisher Bay New Town I, 1958, a fourth generation proposal (from Brian Lee, *Radical Arctic Proposals*)

#### ***Fifth generation***

A fifth generation proposal returns to some of the core principles the First Generation introduced. The building form is again responsive to regional climate and natural forces. In addition, fifth generation proposals address the angle of the sun and the typical wind patterns. The building is then oriented to take advantage of the climatic conditions of the region, instead of fighting them. Windows are placed to prioritize solar gain from low sun angles and buildings positioned to ‘shade’ outdoor spaces from katabatic winds. Another fundamental strategy noted in this generation is prefabrication of building components to improve quality and reduce on-site construction time. A notable example is the small mining community of Fermont in northern Quebec, built in the late 1970s. The main building contains the



The north and west side of Fermont's Mur-Écran has few articulations and smaller amount of fenestration, photograph by Maude Chauvin

<sup>46</sup> Adrian Sheppard, “The Making of a New Town in the Canadian Sub-Arctic” (lecture transcript, Ion Mincu School of Architecture and Urbanism, Bucharest, Romania, July 11, 2007), 10.



**Fifth Generation**

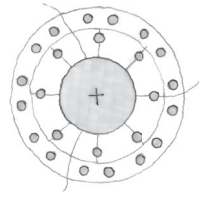
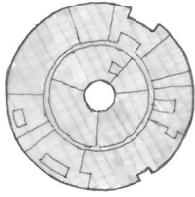

**Fourth Generation**

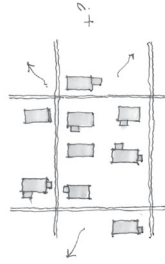

**Third Generation**

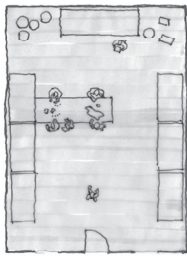

**Second Generation**

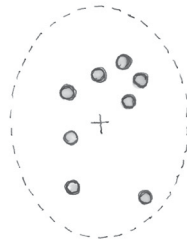

**First Generation**

Diagramming generational building plans and settlement arrangements of the Canadian Arctic

majority of the public program: institutional, commercial, and recreational spaces, as well as containing many residential units, allowing residents to never leave the shelter of the building during the winter if they so choose. The interior spaces are connected by a large corridor system over one kilometre long. The outdoor portion of the town consists of separated housing units in a loose suburban land pattern, protected against the harsh wind by the large form of the main building. The main building form creates a micro-climate on the leeward side and results in snow deposits that are managed by moving it to the south side of the roads to be melted by the sun.<sup>47</sup>



The southern interior side of the wall changes planes and has a variety of fenestration including balconies to take advantage of passive solar; photograph by Gordon Parsons

The fifth generation has many advancements over previous generations but could be developed further. It does not consider the interaction of different groups of users within one community. Arctic communities are often composed of two groups of people: Indigenous and Southerners. Spaces that are programmed to be mutually inclusive benefit both parties through the sharing of physical and intellectual resources. Fifth generation projects such as Fermont also suffer from being a static design. They are designed to address one instance of the regional climate extreme, the winter. In the summer many Arctic and sub-Arctic building interiors can become sweltering due to the amount of southern oriented glazing combined with thick insulation. Ralph Erskine's 1973 proposal for a town in Resolute Bay included window components that had seasonally responsive shutters to control light and temperature levels within the building during the summer months. Having portions of the building that are responsive to all seasons would increase user comfort and would have a positive impact on building performance.

---

<sup>47</sup> Ibid., 10.



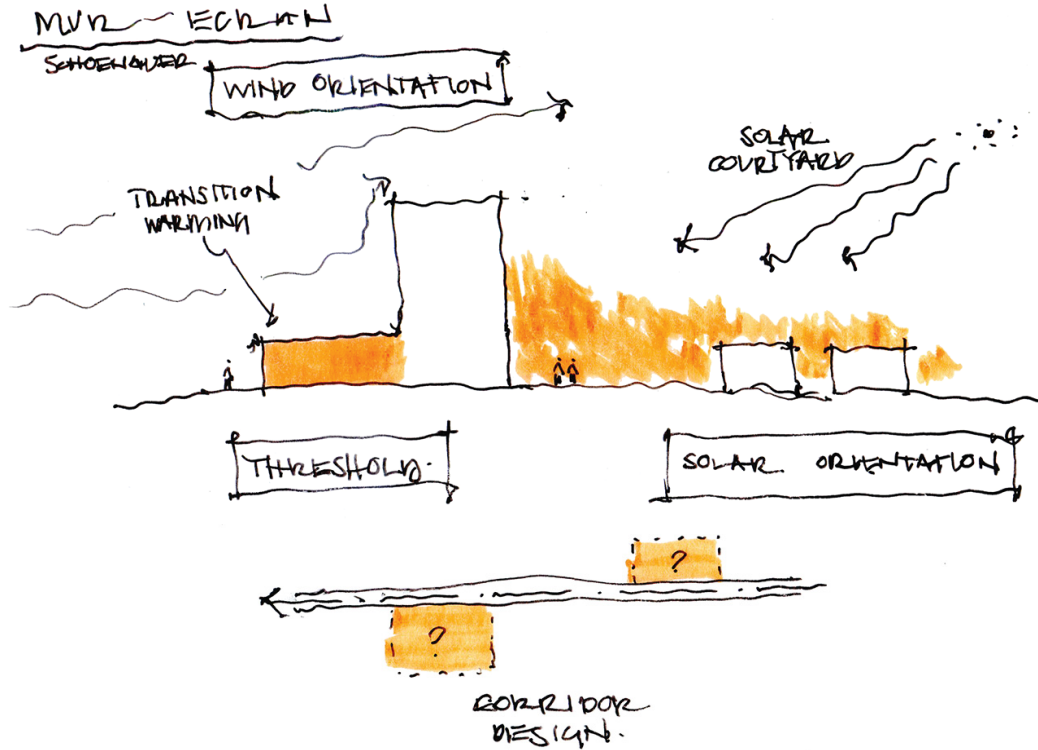

Mur-Écran (Fermont) acknowledges regional conditions but its internal layout makes social interaction challenging for users; data from "Townsite of Fermont" (website), Norbert Schoenauer, accessed December 16, 2018, <http://cac.mcgill.ca/schoenauer/cases/urban-fermont.htm>.

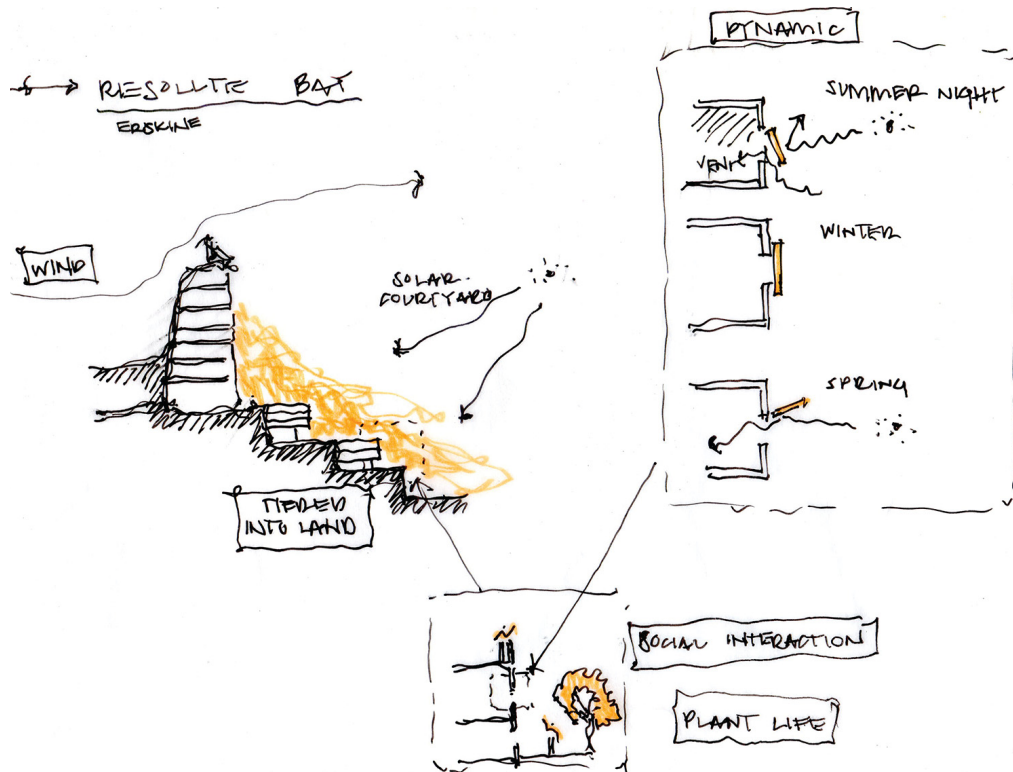

The design proposal for Resolute Bay was influenced by localized climatic conditions and included seasonally dynamic building components; data from "Arctic Town" Hidden Architecture

For these reasons the proposal suggests a further sixth generation of Arctic building to add to Schoenauer's list. Dynamic building elements and multi-user groups programmed with multidisciplinary spaces are characteristics of a proposed sixth generation of Arctic building type.

## Realities of Northern Construction

Construction in the North is constrained by several factors that can increase construction time and cost, and can create unexpected problems for a project. Shipping materials to remote communities increases the cost and design restrictions of a project. Preparations must be made well in advance for building materials to be shipped via sealift to the community. Being limited to the size of a sea container or deck of a barge puts restrictions on material type and size. Splitting larger portions of a building into smaller modules can result in savings of time and money, in some cases 25% of the construction budget.<sup>48</sup> Northern communities typically do not have large construction vehicles such as bulldozers and cranes ready to be rented or purchased, so shipments must also bring up heavy equipment if necessary. Considerations must also be taken for solar exposure during the construction process. While construction projects can benefit from long summer hours, larger equipment can suffer in ground conditions resulting from warmer temperatures. For the installation of two large wind turbines in Kotzebue, Alaska, the construction crew waited for the ground to freeze before moving the large cranes into place to lift the final pieces, to avoid sinking into the wet tundra. The crane rented for the project then had to overwinter in the community despite not working, an added cost that had to be



Unloading construction material at the Princess Elizabeth Antarctica Research Station. A similar method would be used to unload material in the Canadian Arctic; photograph by International Polar Foundation, "Unloading is always an adventure!"

<sup>48</sup> Interview with Guy Gerin-Lajoie in *Many Norths*, 159.

taken into account.<sup>49</sup> Finally, northern construction projects face challenges of a lack of local skilled labour. Importing skilled labour is expensive and can be detrimental to the community and should be avoided. Prefabricating building components saves on importing skilled labour and typically increases quality of the module. Modules arrive on site and can be designed to simplify and expedite construction. The highly skilled work to create the module is done off-site, leaving the on-site assembly to be done by less skilled construction labour and minimal equipment.<sup>50</sup>

---

49 Conversation with Matt Bergan, Kotzebue Electric Association, Kotzebue, Alaska, May 2018.

50 Interview with Guy Gerin-Lajoie in *Many Norths*, 159.

## CHAPTER 5: DESIGN PROPOSAL

### Situating + Seasonality

Several communities exist within the Canadian Arctic. By reviewing locations, town assets, and marine traffic patterns Cambridge Bay emerges as the strongest contender for the proposed intervention. It is centrally located within the Canadian Arctic, hosts a variety of relevant programs, has experienced higher levels of nearby ship traffic relative to other communities, and has many polar flight routes cross over it. Cambridge Bay is the home of the recently completed Canadian High Arctic Research Station (CHARS), whose research aspect could form a partnership with the environmental response team. The nearby North Warning System (previously DEW Line) station monitors aerospace traffic; its office stations would be amalgamated into the new centre. Situating the project on the coastline of Cambridge Bay allows access to both land and marine environments. While visiting the community in August 2018, a central axis of pedestrian activity was identified that ran from the downtown intersection (containing key educational and public buildings) to the waterfront. Working from this pre-existing axis is beneficial.

Cambridge Bay and the Canadian Arctic as a whole have a dramatically different climate than Southern Canada. Spring in Cambridge Bay happens in May and June, and although the bay and surrounding waters still have ice, many residents are out on the land. The bi-annual caribou migration and annual bird migration occur during the spring, temporal food sources that are relied upon by the local community. During these days the air is warm and the sun is up for most or all of



Cambridge Bay shoreline on an overcast afternoon in the summer, Cambridge Bay, August 2018



The Canadian High Arctic Research Station completed, Cambridge Bay, August 2018



The Northern Warning System complex, Cambridge Bay, August 2018

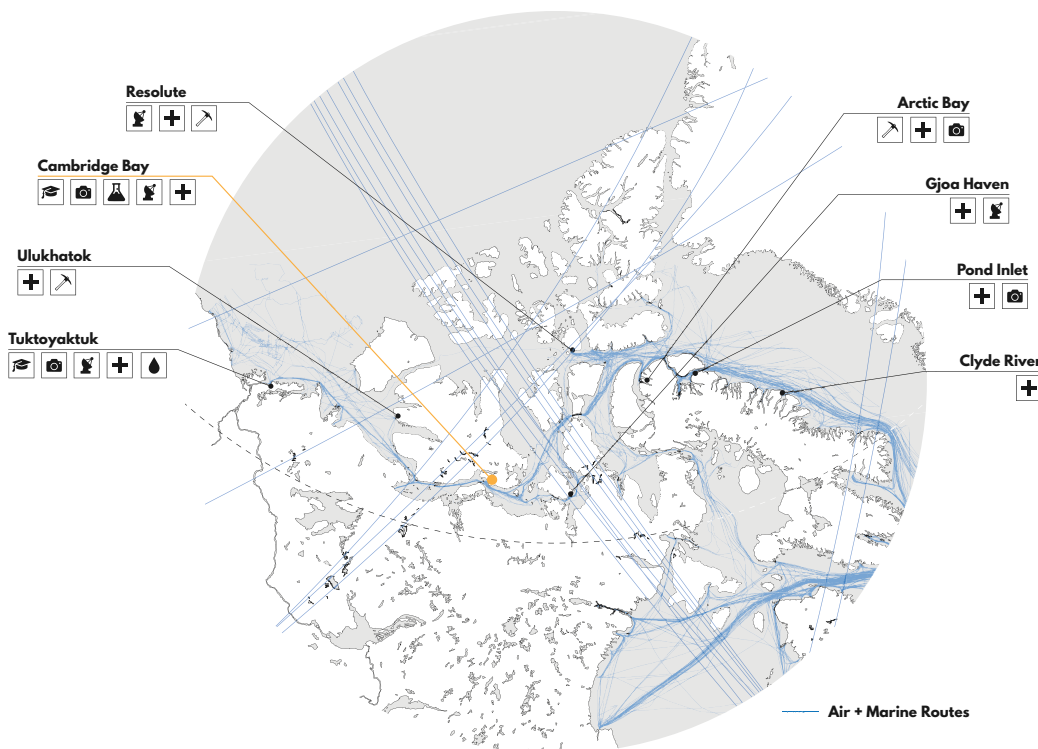

Map of the Canadian Arctic communities cataloging relevant program in each, also noting marine and air traffic routes; data from Natural Resources Canada, The Pew Charitable Trusts, FlightAware



Town plan of Cambridge Bay highlighting existing structures within the community; data from site visit in August 2018, supplemental data from Aarluk Consulting Inc. *Infrastructure for a Sustainable Cambridge Bay*

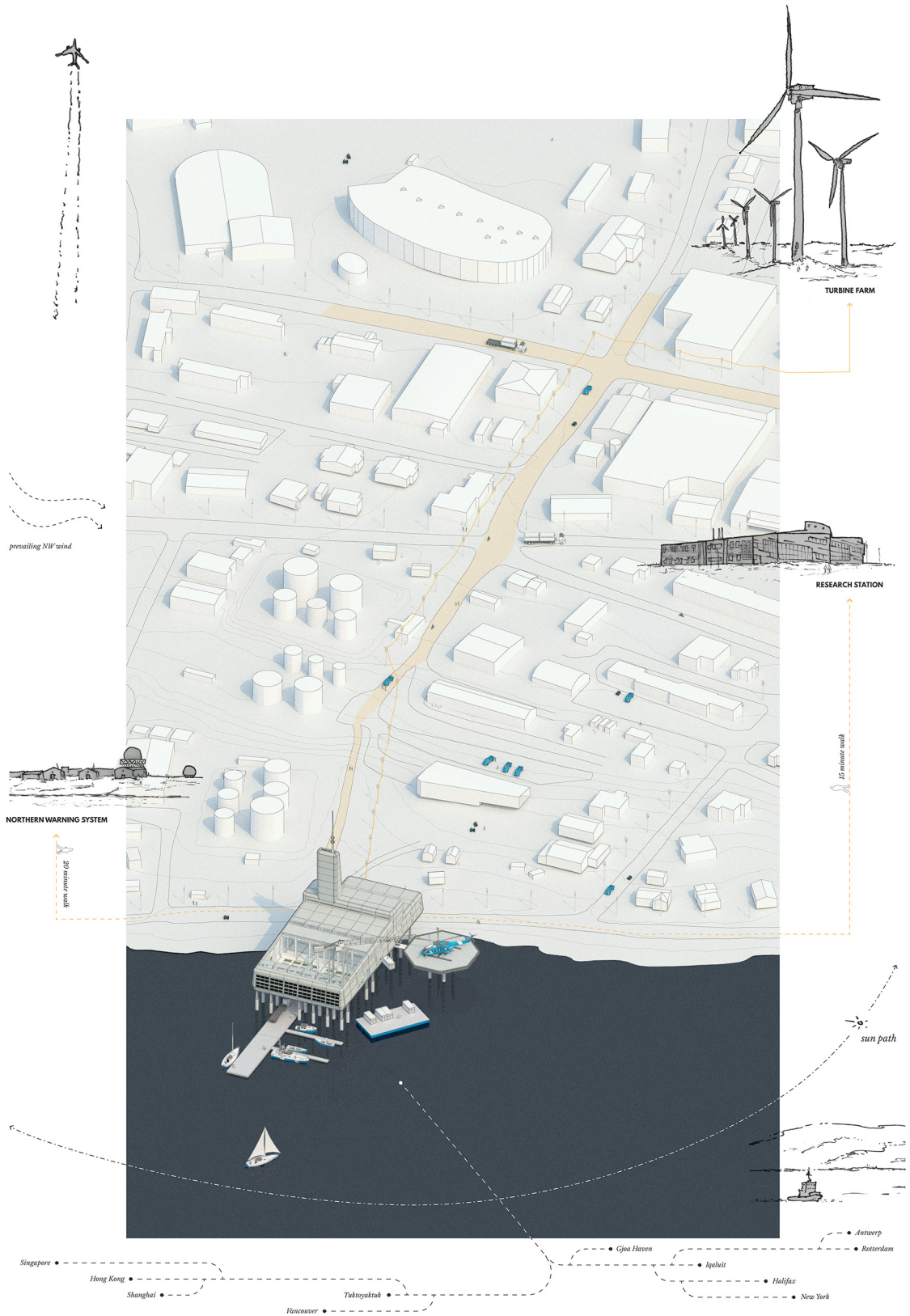

The shoreline of downtown Cambridge Bay, noting the central axis, proximity to supporting program, and environmental forces that influence the project; data from site visit in August 2018, supplemental data from *Infrastructure for a Sustainable Cambridge Bay*

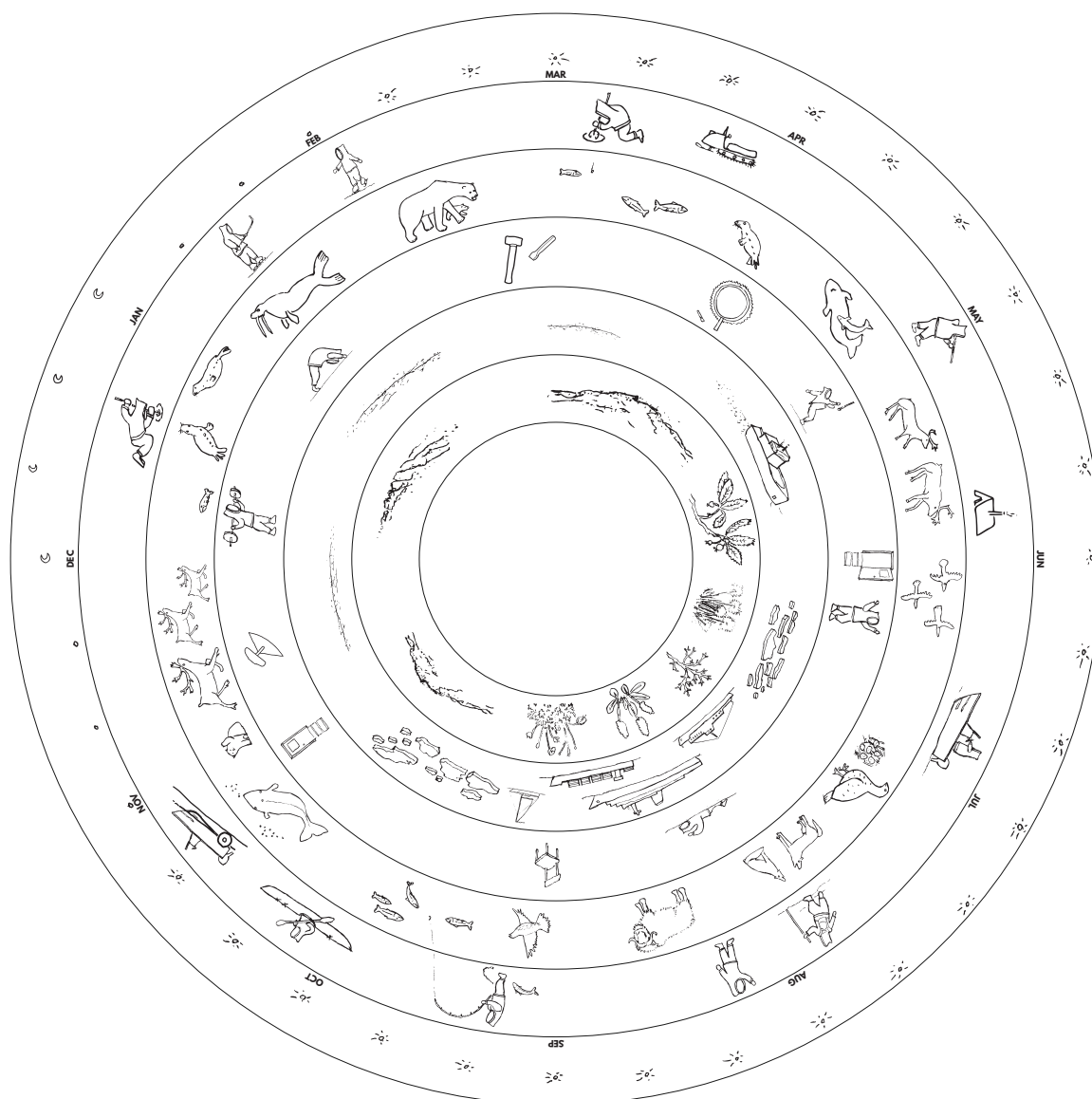

Annual activity diagram of Cambridge Bay; data from N.A. Carter, J. Dawson, J. Knopp, J. Joyce, M. Weber, Z. Kochanowicz, O. Mussells, *Arctic Corridors and Northern Voices: Governing Marine Transportation in the Canadian Arctic (Cambridge Bay, Nunavut community report)* (Ottawa: University of Ottawa, 2018), 11-19.



Yearly activity timeline of Cambridge Bay identifying key times during the year where the proposed building would respond to external activities and conditions; data from N.A. Carter et al., *Arctic Corridors and Northern Voices*, 11-19.



the day (from the middle of May through the middle of July). People are generally up for longer periods of time, enjoying the respite from the long winter past. Immediately following the melting of the sea ice, boats are placed back into the water and fishing and marine travel begin in earnest. While the water along the Northwest Passage is open, the boat types discussed earlier are present, either making a stop in Cambridge Bay or passing by only 30 km away from town. The arrival of the largest cruise ships, as well as the resupply barges, begins to mark the end of the shipping season, and as fall begins, so does freeze-up, another dramatic time of year when boats are hauled out of the water. With the water frozen over, the caribou migration occurs again, which is paired with a hunting season as frantic as the one in the spring. As winter begins, the sun dips below the horizon longer each day, until it no longer rises. From the end of November to mid-January Cambridge Bay experiences no sunlight, paired with temperatures commonly below -40C. Activity slows down and people sleep for longer periods of time, focusing more on indoor tasks such as maintenance. It remains this way until the sun is up for more than a few hours each day, then the life outdoors begins again. This cycle of light and dark, warm and frigid, water and ice influences the lifestyle of the inhabitants, and in turn also influences the functionality of the proposed program for the building.

## **Building Program**

The introduction of a fourth Joint Rescue Command Centre based in the Canadian Arctic is essential in order to provide regionally specific and timely delivery of assistance.<sup>51</sup> As large construction projects do not happen

---

<sup>51</sup> Leroux, *The Arctic SAR Region*, 27.

often in remote communities, the centre cannot be one-dimensional; it must be able to host a variety of programs that address a number of problems and serve different types of users. The proposed centre hosts land, marine, and air search and rescue resources. Localized assistance would greatly benefit local people travelling and hunting on the land, as well as transient marine and air traffic. An environmental response team will also operate out of the centre, with the ability to address environmental concerns and remediate spills. Having both search and rescue and environmental response in one space increases the overlap of equipment and crews, and thus the ability to learn from one another. The inclusion of navigation, communications, and monitoring systems is critical to the operation of both programs and is also included. This will allow the building to monitor ships traveling through the Arctic and accurately advise them of ice and weather conditions. Being aware of traffic and operations throughout the Canadian Arctic is essential in order to ensure the safety of Arctic travellers, both local and foreign. It also makes a stronger case for reinforcing Canadian sovereignty. Maintenance spaces within the building will ensure first responders' equipment (both land and marine) is well maintained and prepared for use. Maintenance space will also include space for both municipal services and local people's vehicles, allowing for sharing physical resources (such as tools) and intellectual resources (such as how to repair a certain part). While visiting Cambridge Bay in August 2018 it was noted that many vehicles were stored and maintained outside due to a lack of indoor garage spaces. Storing vehicles in the elements can accelerate their aging and increase the amount of maintenance required. During the summer, when



Combined office space permits faster sharing of information between users

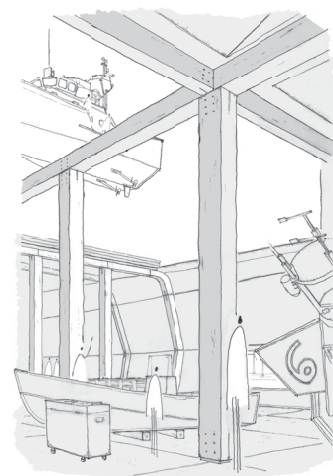

The roof-mounted crane removing a vessel from within the workshop space

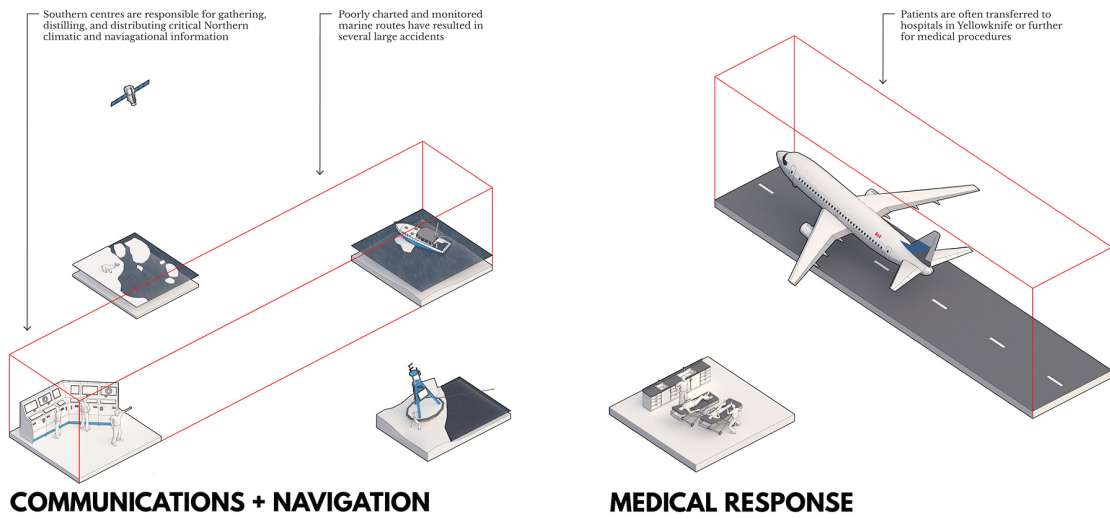
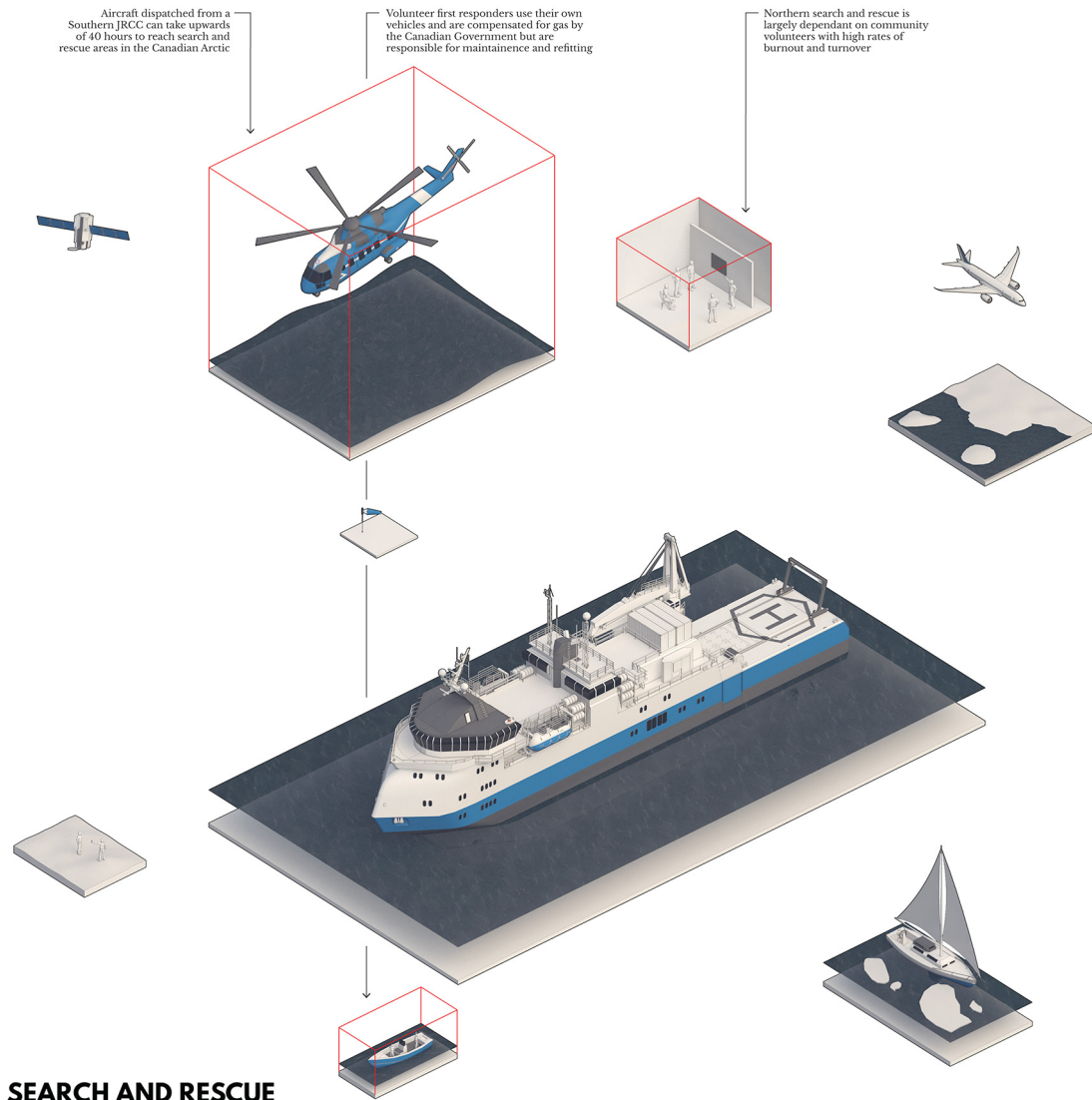

Program drawings showing current issues in the Canadian North, highlighting risks that are most significant, which the proposal addresses

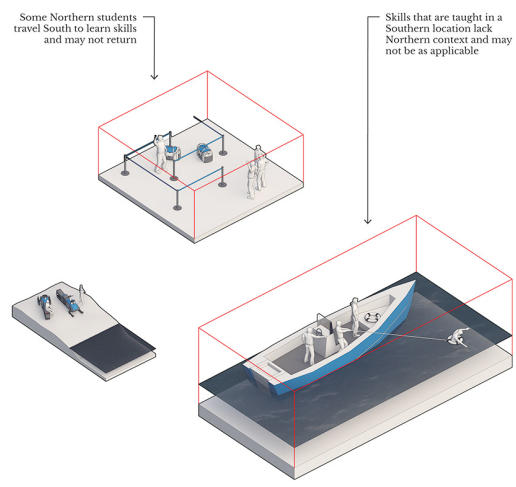
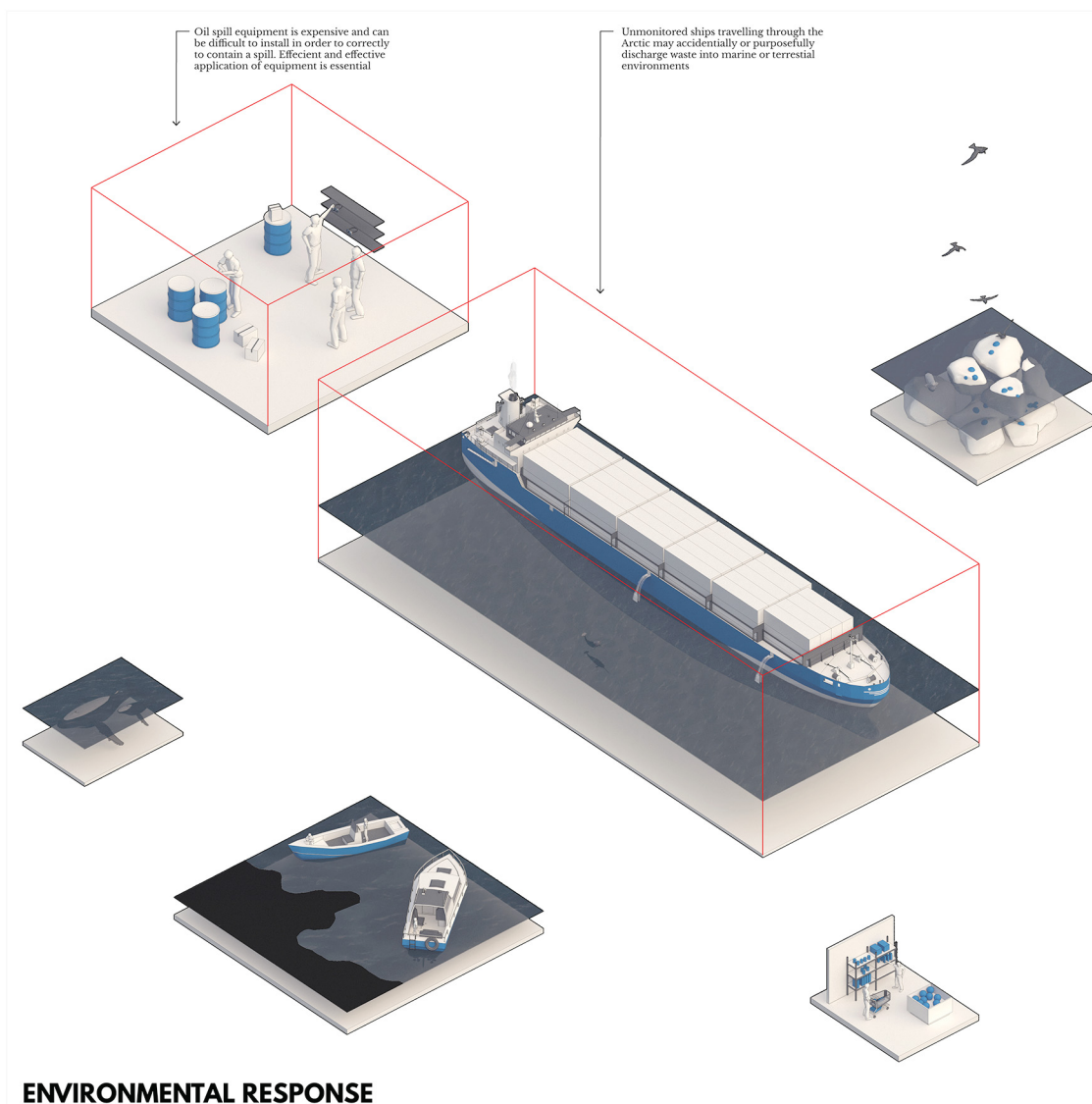

Program drawings showing current issues in the Canadian North, highlighting risks that are most significant, which the proposal addresses

the marine portion of the space is not in use, the large, well-lit enclosed area is used as a greenhouse to grow small greens for the town. When considering a rescue program, it is essential to offer medical facilities in close proximity. For this reason, a medical centre is included in the program of the building, supporting acute injuries and having a number of ward rooms. This space functions as a replacement for Cambridge Bay's current aging medical centre. A critical part of the building program is the educational spaces. When people are interested in post-secondary education in the North, they have few local options, with only a handful of programs being offered in any one community. To pursue other career paths, a student would have to leave their community, and often Northern Canada entirely, to access other education programs. Upon graduation there is a chance their profession will not have any opportunities in the Arctic, or the training they receive would not be Arctic-specific and therefore less or not applicable in the region. (For instance, water search and rescue training in Lake Ontario would be different from training in the Victoria Strait.) By having learning spaces within the proposed infrastructure, students interested in any hosted program could receive Arctic specific on-site training. This benefits the local community by offering additional educational opportunities closer to their home. It also benefits the recipient of their training, as they will be more familiar with their chosen field in an Arctic context. Amalgamating many complementary programs in one building allows for sharing of resources and increases potentially beneficial chance contact between different user groups. To optimize program layout, the initial programmatic size requirements were identified, as well as any external adjacencies required (for instance, ground

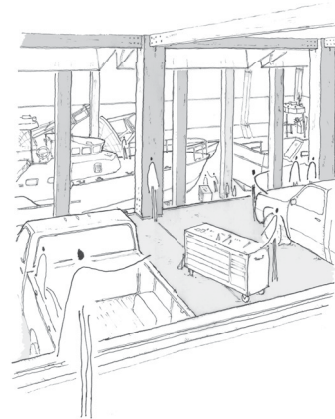

Learning by proximity and participation: the teaching spaces look into workshops

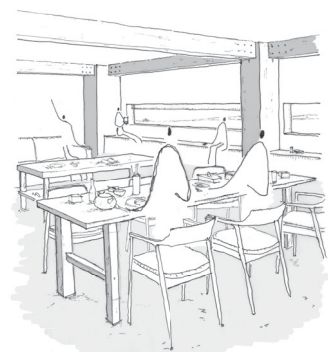

Common kitchen and lounge space increases casual cross-discipline interaction

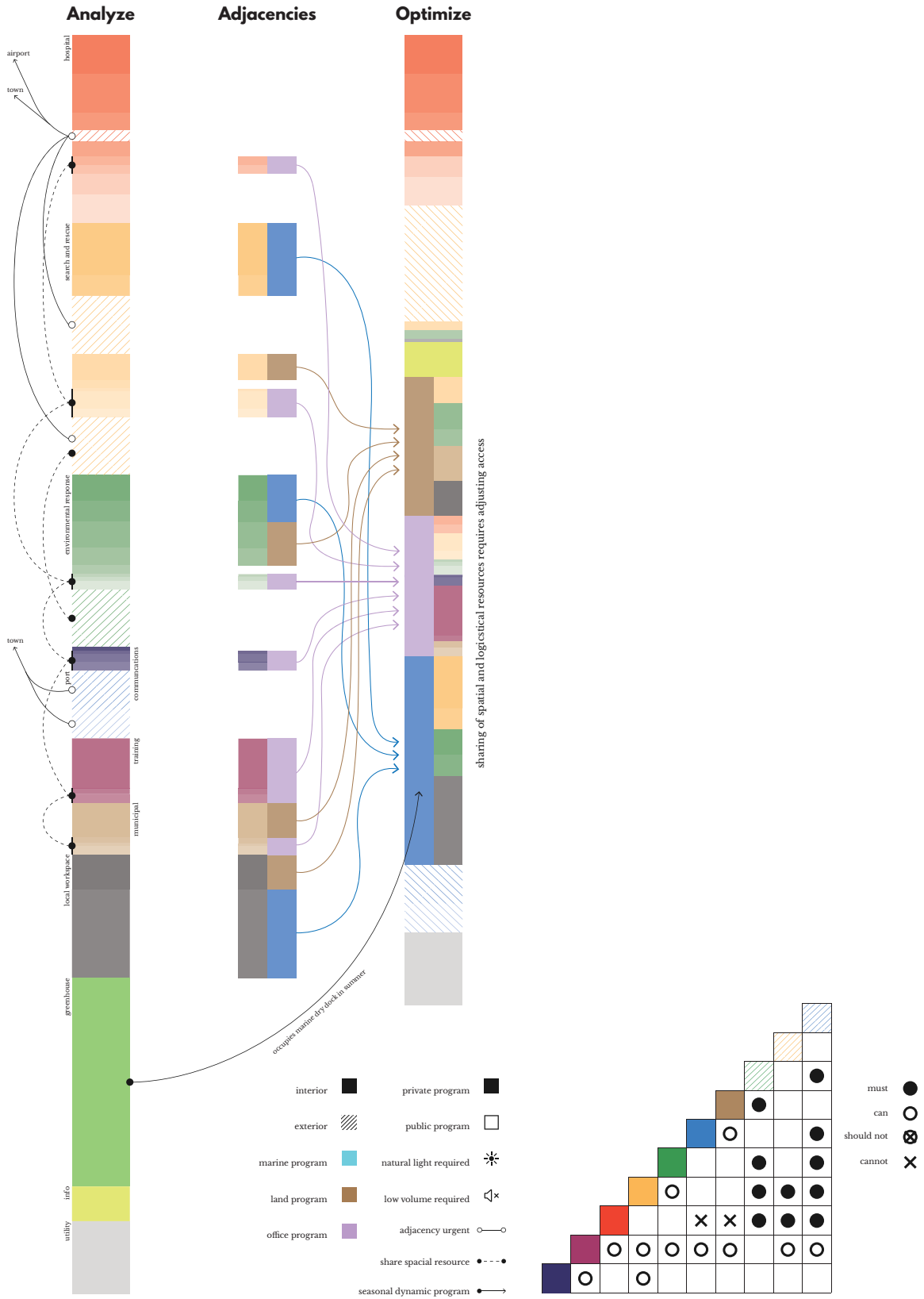

Left: program diagram to identify similar program spaces that can be integrated. Right: adjacency diagram to identify different types of adjacencies: must, can, should not, and cannot.

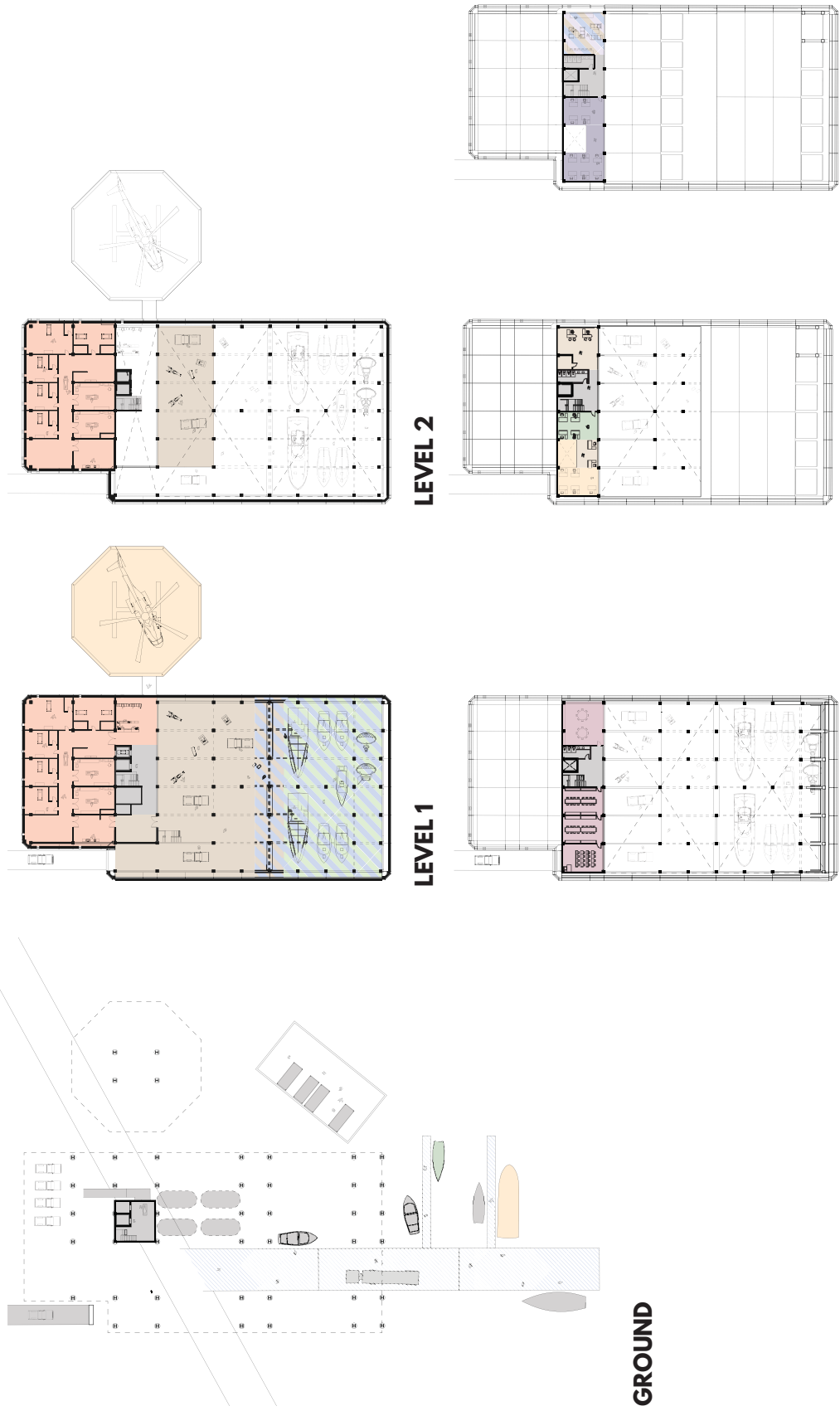

**LEVEL 5**

**LEVEL 4**

**LEVEL 3**

**LEVEL 2**

**LEVEL 1**

**GROUND**

Floor plans with program adjacencies as per the optimized layout. Diagonal stripes indicate shared or temporary use of space

access to town). At this stage, repeated programs, such as the need for a dock space for both locals and search and rescue crews, were also noted. Repeated programs can then be combined and reduced in overall size. The next step categorizes programs into three types: office space, land space, and water space. After being grouped, they can be re-inserted into the program list. Shuffling the program to optimize adjacencies permits the sharing of physical and intellectual resources. The final aspect of the program analysis was to identify overarching program adjacencies, using a system that identifies if programs must, can, should not, or cannot be adjacent to one another. With program optimized and adjacencies identified, plans and sections could be generated.

## Construction Assembly

The proposed centre has a modular design, both structurally and in its cladding system. The design takes cues from the Princess Elizabeth Research Station in Antarctica, a project that was constructed in Brussels before being disassembled and shipped to the Antarctic in pieces. Smaller structural steel and glulam members are easier to transport and are easier to assemble and minimize on-site waste. Utilizing bolted connections reduces the required skill ceiling for construction, and would allow the hiring of more Cambridge Bay locals for the construction of the project. Further polar specific design strategies can be derived from the Antarctic station, which acknowledges climatic and social design cues. It is designed to operate with a net-zero footprint, lowering the amount of imported fuel it requires. It houses a water treatment unit, generates its electricity through renewable photovoltaic panels and wind turbines, and



Panels are lifted into place at the Princess Elizabeth Antarctica Research Station; photograph by International Polar Foundation, “Passive Building Techniques”



Bolted connections between structural members simplify on-site construction and reduce construction time; photograph by International Polar Foundation / René Robert



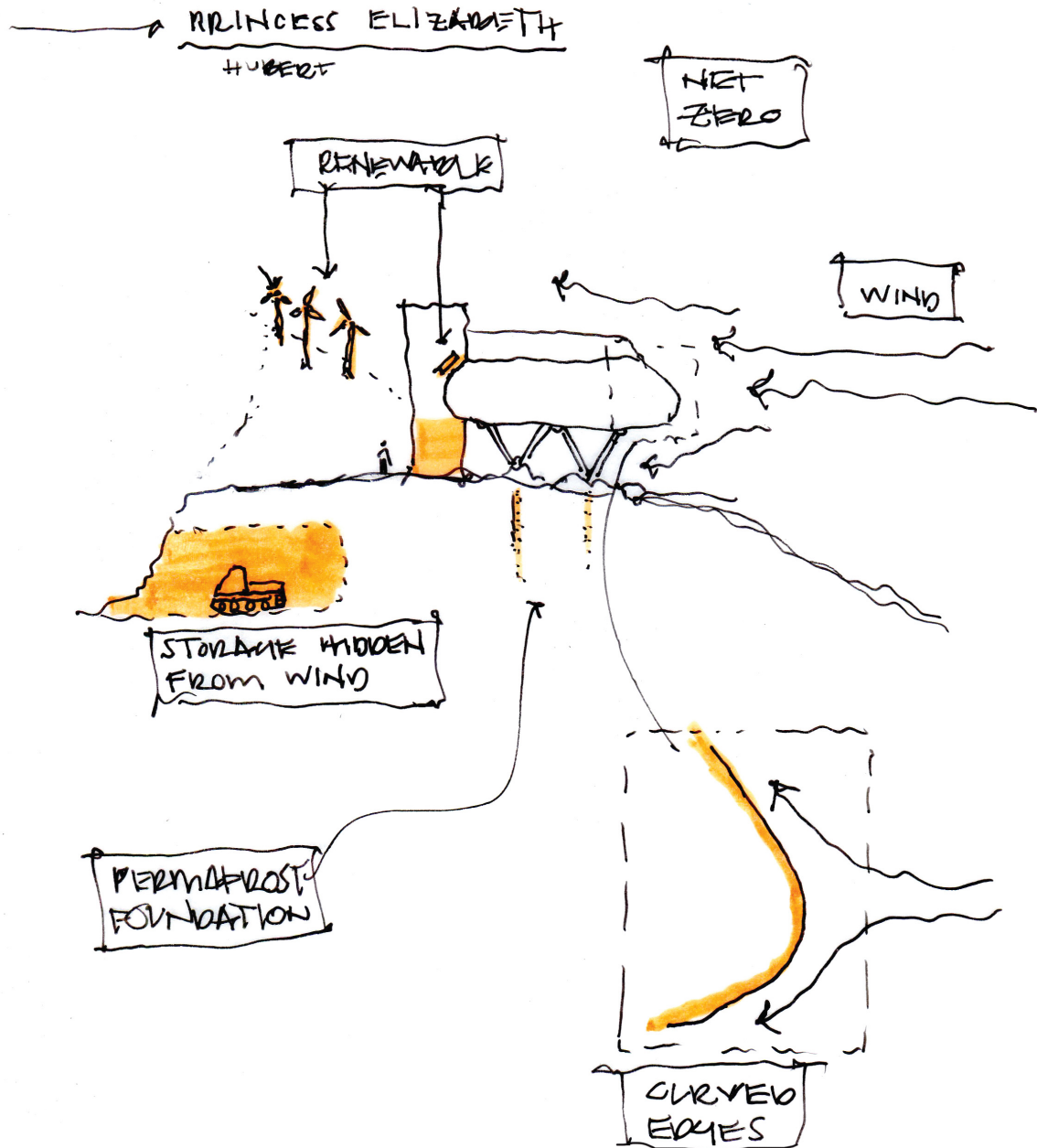

Analysis of the Princess Elizabeth Station, noting several polar specific design strategies; data from International Polar Foundation, "Princess Elizabeth Station: The First Zero Emission Polar Research Station."

utilizes several building systems to permit a comfortable ambient temperature inside with little energy input. The building shape and orientation also reflect the climatic conditions of the area. The structure is lifted from the ground and entrances are positioned to face away from the wind. The wind also influences the cladding of the building, curving it to encourage snow scouring. These architectural strategies are visible in the building proposed for Cambridge Bay.

### **Dynamic Elements**

As noted in Chapter 4, to design in the Arctic exclusively for either the summer or winter season will result in the failure of the building. Winter-specific buildings retain too much heat in the summer and let in either too much or not enough light. Summer-specific buildings lack thermal performance in the winter and can encounter moisture and mould problems if not detailed properly for the spring melt. To design for the 'middle' of the seasons will present challenges of its own, however, likely a combination of the two situations mentioned above. To move towards a sixth generation Arctic building proposal requires elements of the building to adapt to the climatic differences between the Northern summer and winter. When the building changes in response to climatic conditions and human activity, it is both a winter building and a summer building, allowing it to be used more effectively throughout the year, regardless of weather condition.

The building responds to two major seasonal changes: climate and human activity. Responding to a seasonal change involves the activation or modification of a building element by a user; responding to a change in human activity

requires a programmatic reassignment of space. Seasonally responsive building elements operate as mediators between the building's users and the climatic conditions. For example, if the user wants an interior office space to be lit with natural light, the operable window shading is lifted. In another example, if a building user is finding a workspace too warm, shading can be shut and wall panels partially opened to introduce a cross breeze. Mediating between a user and the weather requires a gradient change and not a binary one. Programmatic changes are internal, and would have specific dates when they would change according to human schedules. In the proposed building there are several classrooms. When classes are completed for the term, those rooms are turned over to the community to be used for gatherings, meetings, etc. There is another space that functions as a tourist information centre during the summer months, but as the tourism slows, it adapts to serve as a navigation centre for local population travelling on the ice and land. The intention behind dynamic building elements and programmatic changes of space is three-fold: maintaining operational effectiveness of programs over multiple seasons, ensuring a comfortable work environment for humans, and increasing building energy efficiency. The following drawings examine the building in its summer and winter states.

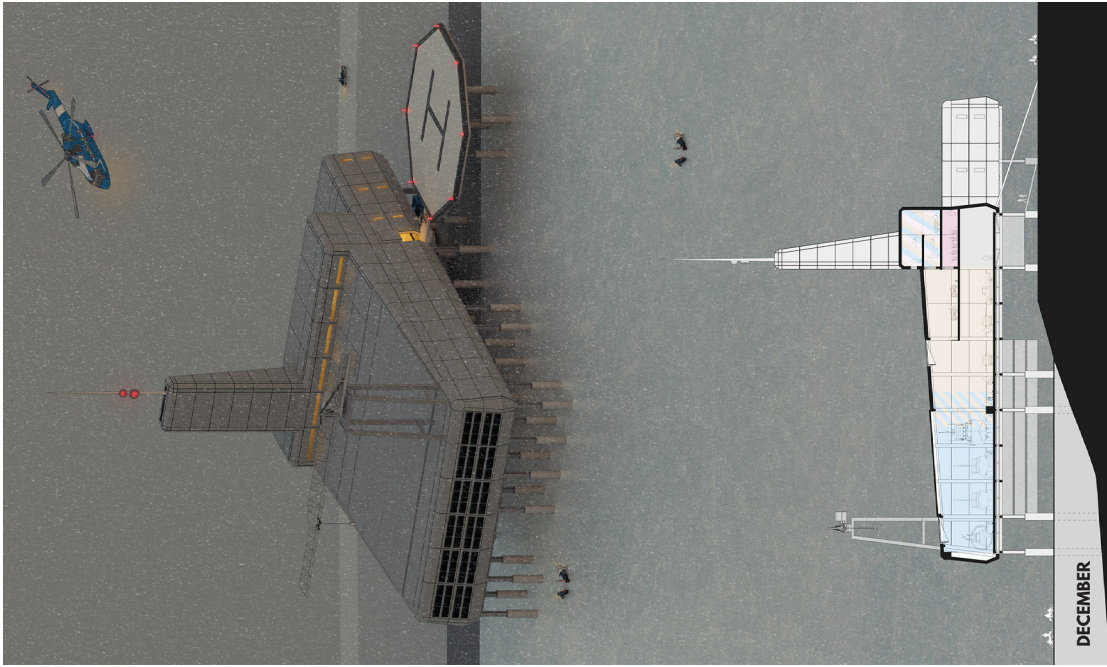
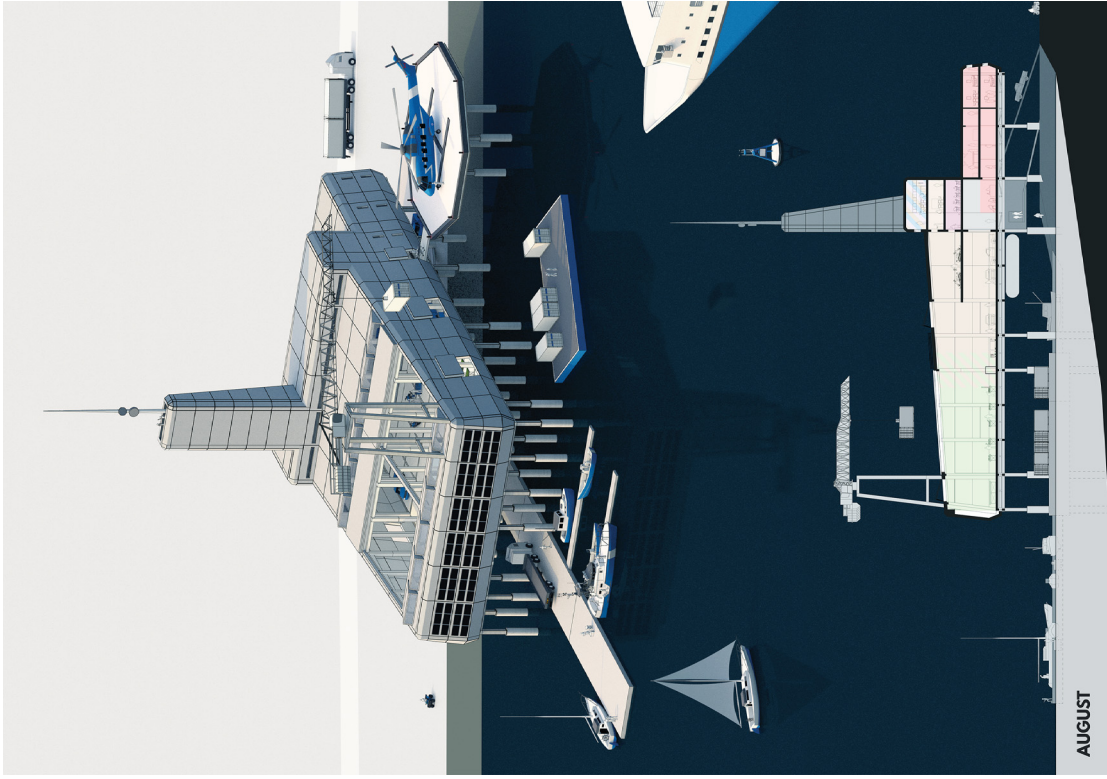

The building in winter state (left) and summer state (right), with corresponding sections.

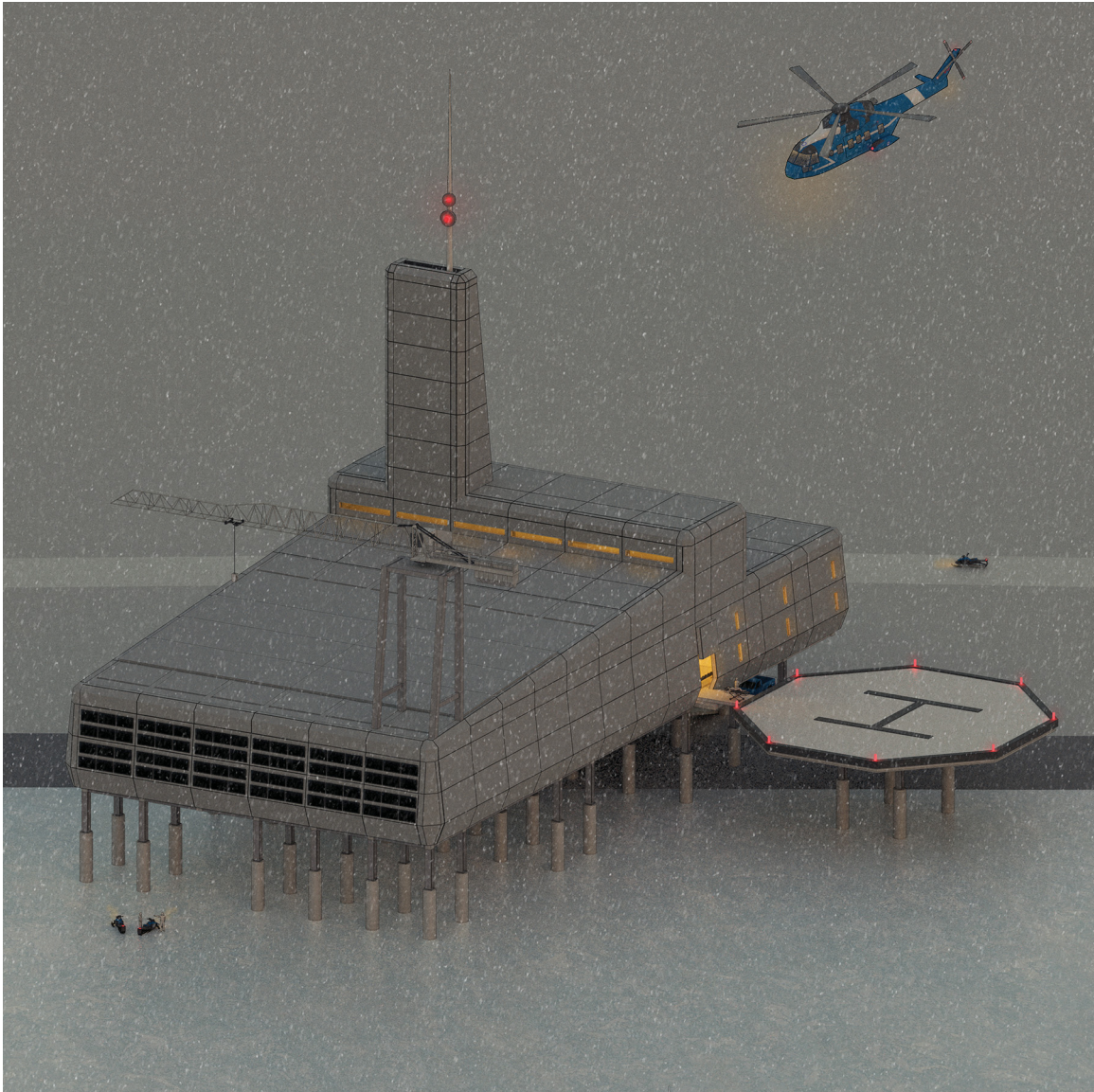

The building in its winter state. Note the minimal amount of glazing exposed, to reduce heat loss. The building is still able to provide emergency services, with human and helicopter entry located on the leeward side of the building to ease access in the wind and blowing snow

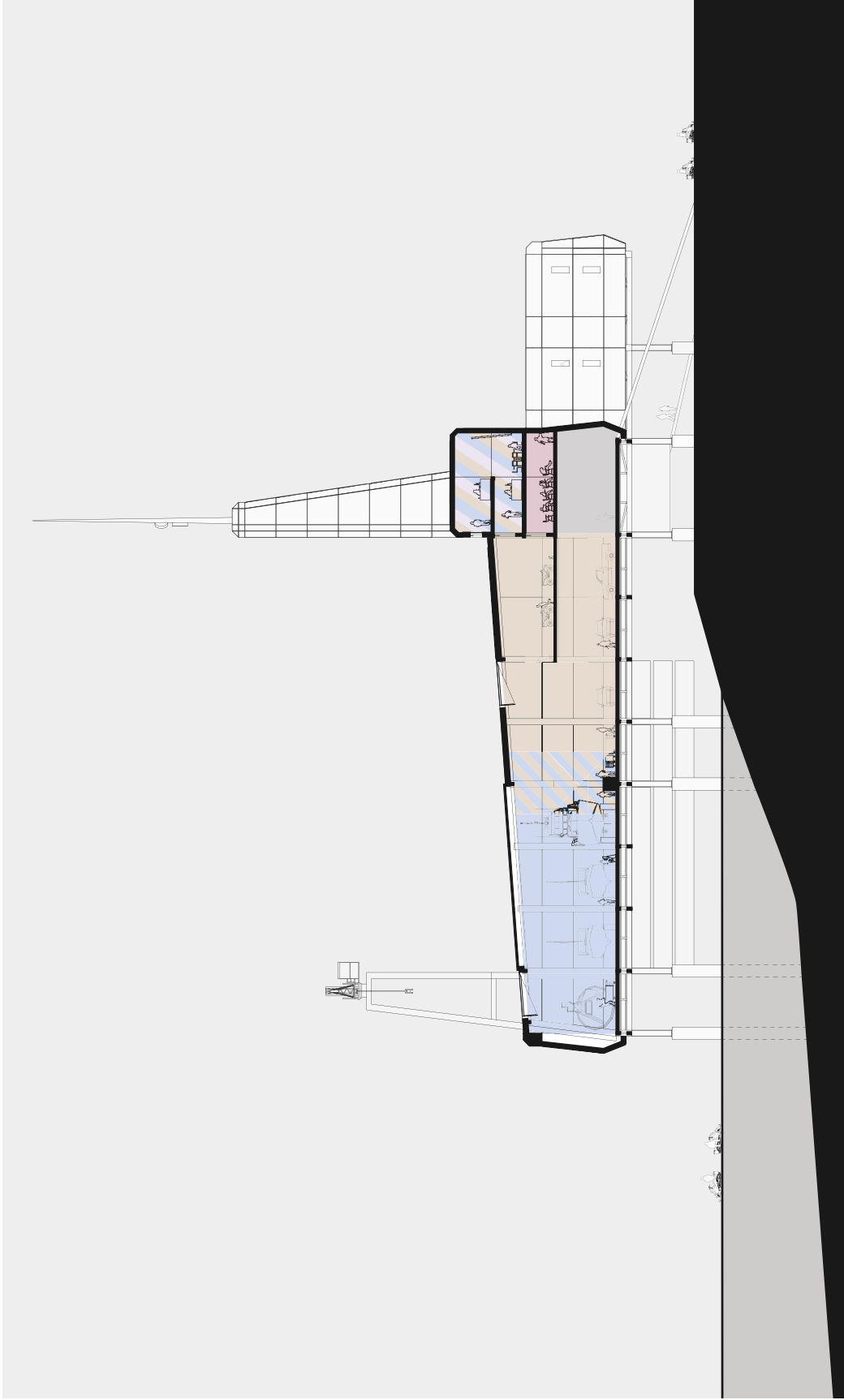

Section through the building in its winter state, with skylights closed, and workshop with marine equipment. Diagonal stripes indicate shared or temporarily occupied space. Note the shared tool storage between workshop bays and shared office space. Classrooms (in red) are able to observe workshops through soundproof glazing

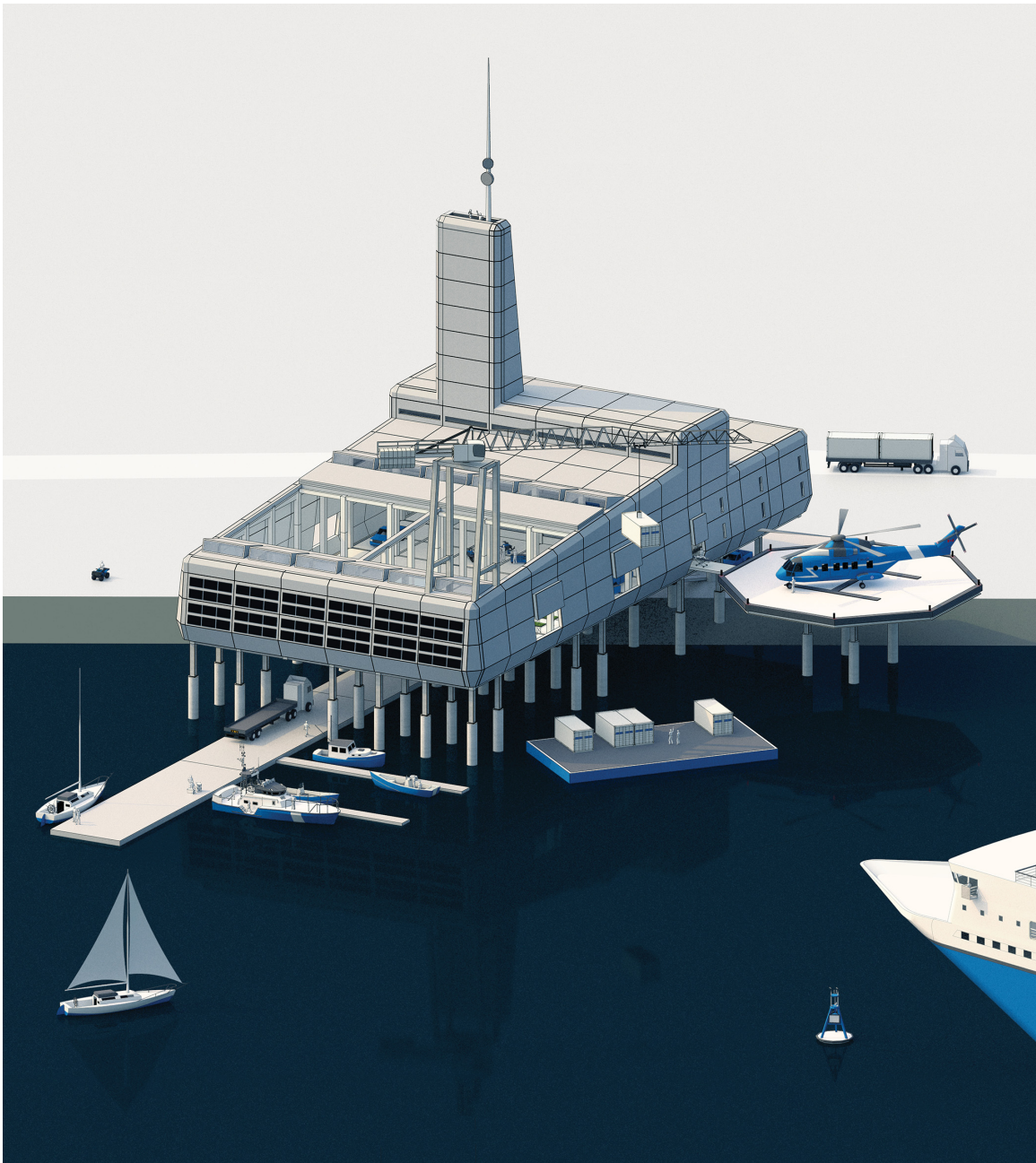

The building in its summer state. Note the open glazing to allow natural light, and open wall panels to induce a cooling cross breeze. Roof panels are opened to facilitate movement of vessels and equipment within. Dock is extended for the use of locals, government vessels, and visitors. The fuel, water, and waste buoy is visible, deployed to service deep draft ships anchored in the bay.

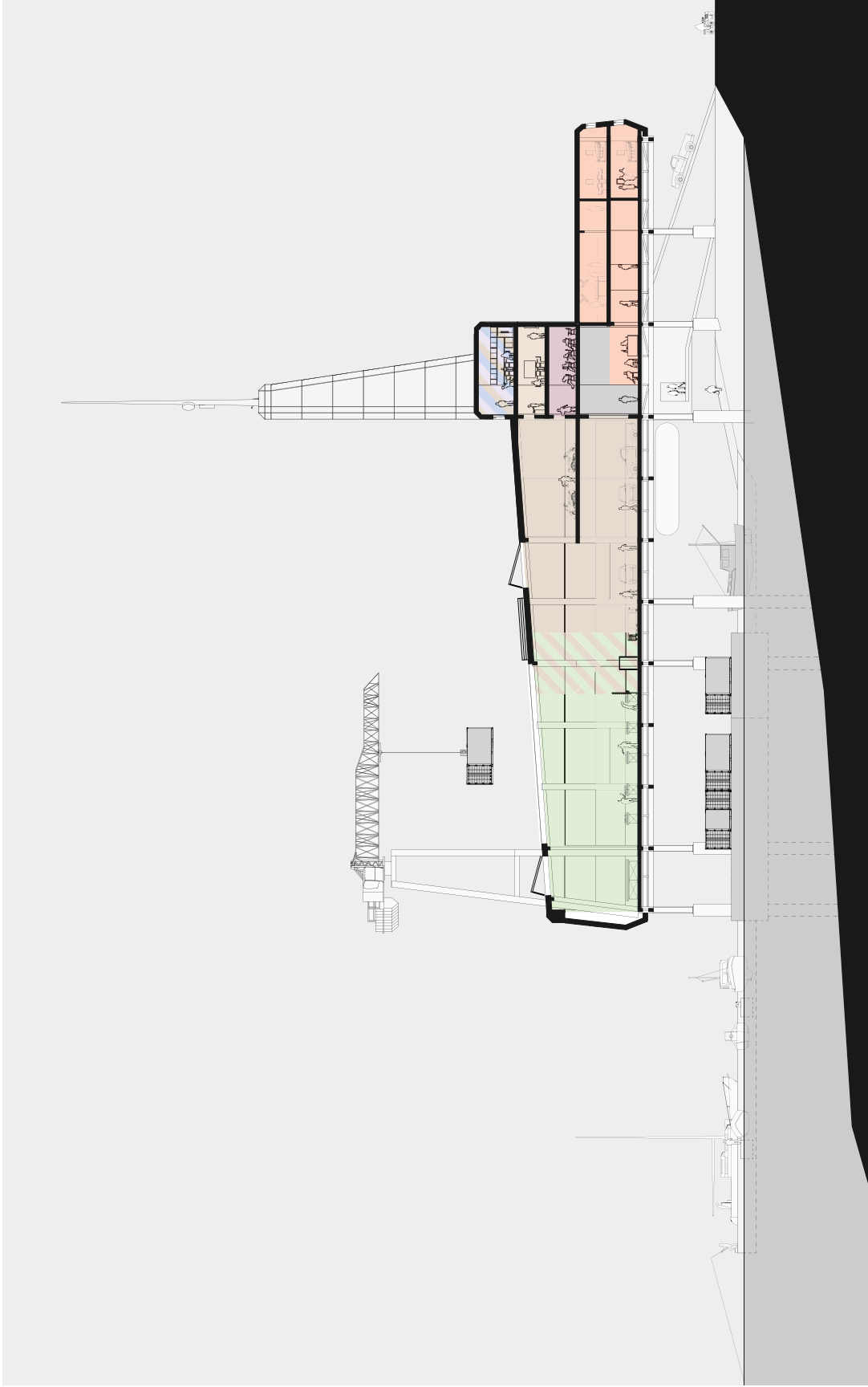

Section through the building in its summer state. Note the open skylights, deployed dock, and crane unloading a sealift barge. Inside, the marine workshop has changed to a greenhouse. The shared kitchen/lounge space is shown on the top floor



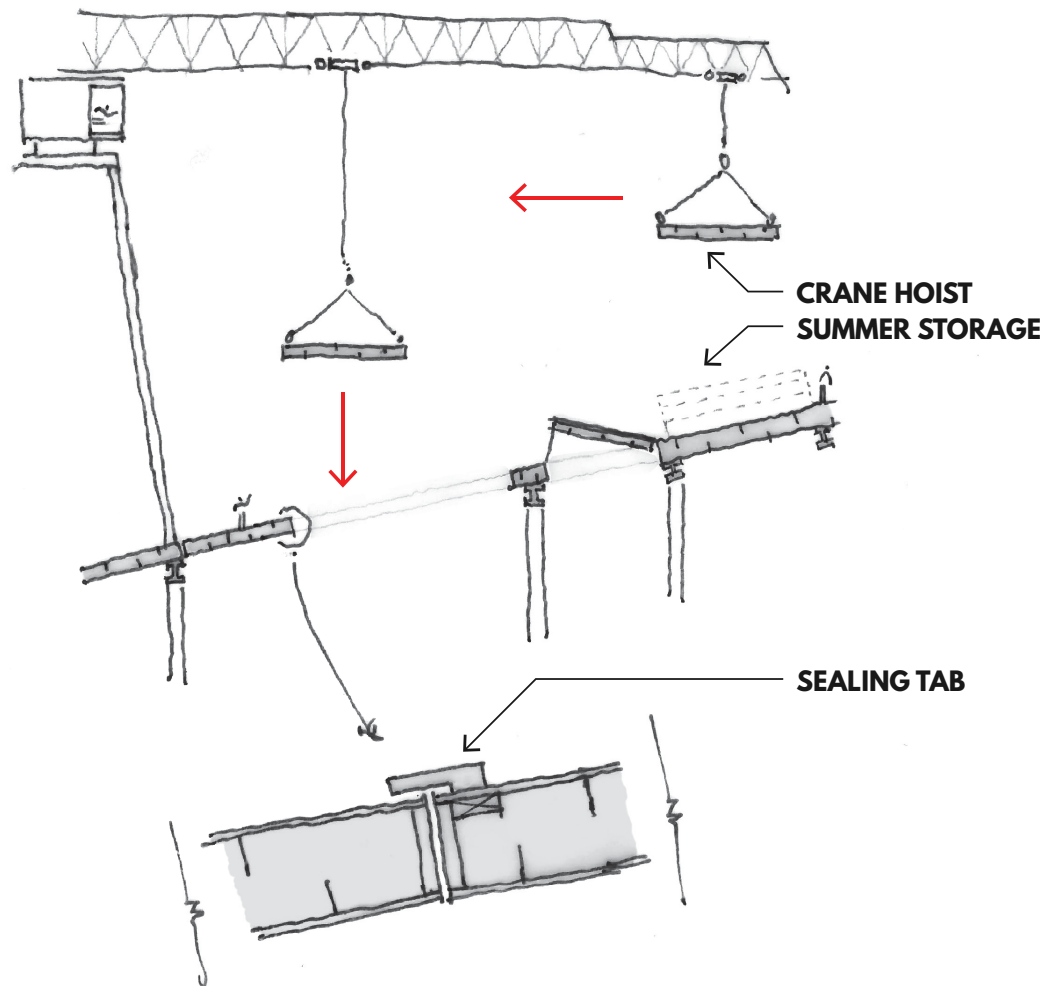

## REMOVEABLE ROOF PANELS

MAY + OCTOBER

When the weather begins to warm and access is desired to the marine equipment, the roof-mounted crane lifts off the roof panels. This also allows increased natural light and ventilation into the workspaces below. When temperatures decrease and marine equipment is stored, panels are re-installed. As the workspaces are only semi-conditioned, the design of the seal between panels focuses on durability rather than creating a perfect thermal barrier.

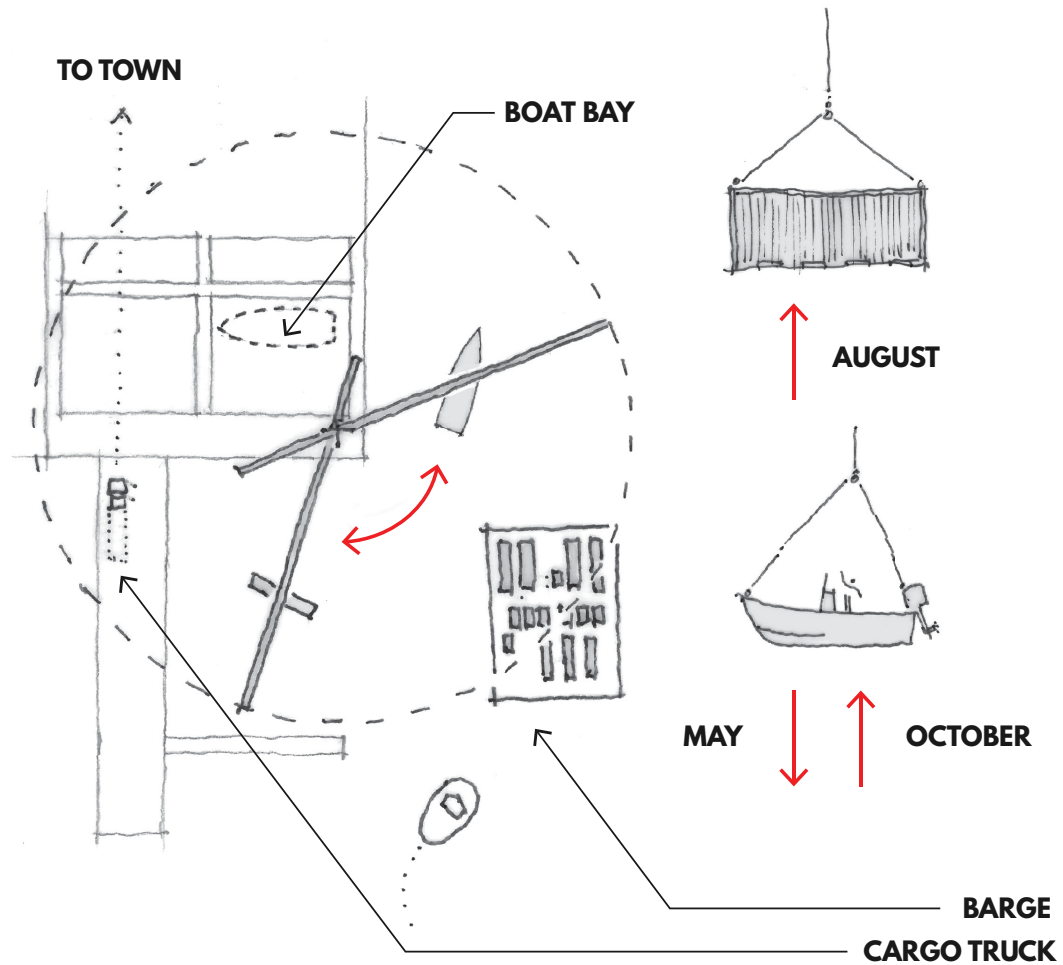

## VESSEL + CARGO LIFT

MAY - OCTOBER

The large crane is also capable of moving cargo, vehicles, and equipment. Once the roof panels are opened, boats and marine equipment can be moved onto the water. Cargo from supply barges, traditionally off-loaded with a purpose-built vehicle, can be lifted onto waiting trucks, to be delivered into town.

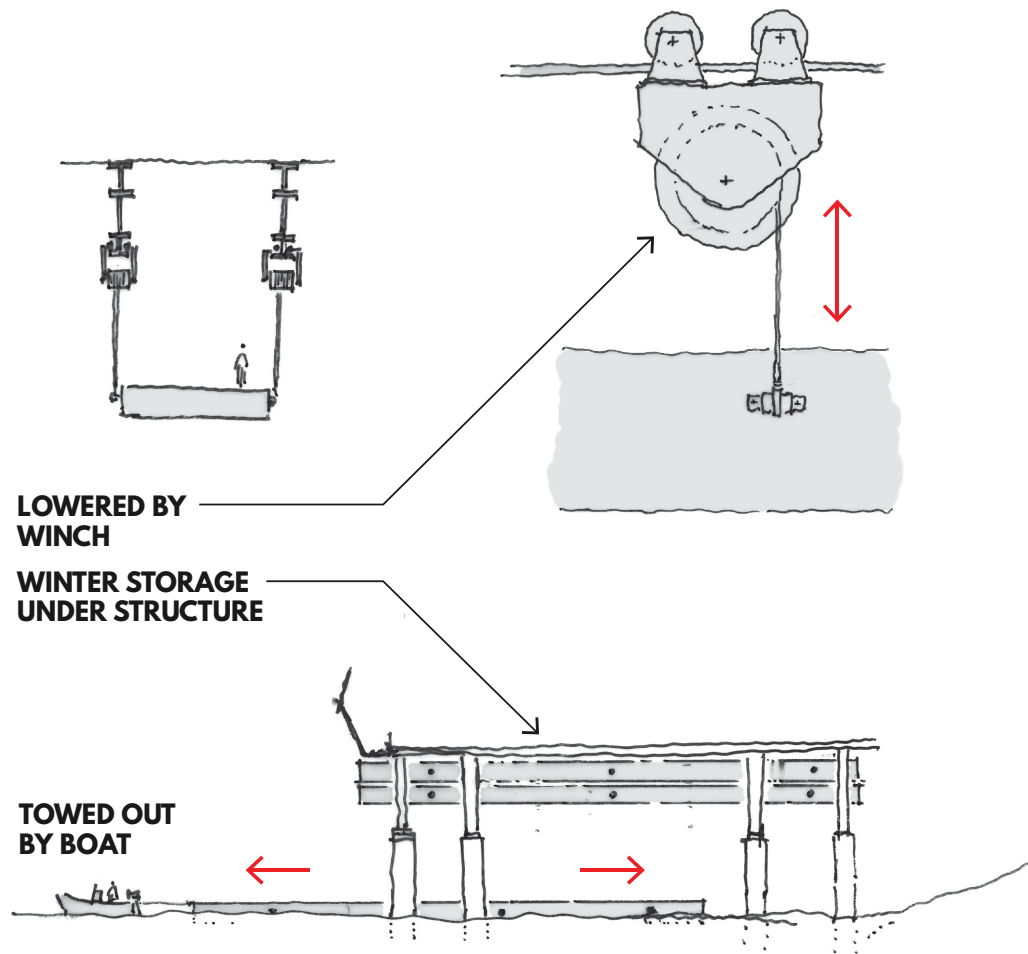

## DOCK DEPLOYMENT

MAY / SEPTEMBER

Each winter the waters around Cambridge Bay freeze. Other polar communities with docks drag them out with large vehicles and equipment (Kotzebue, Alaska); however, the proposed building is capable of deploying the dock itself. During the winter the docks are stored below the structure to prevent damage from the elements.

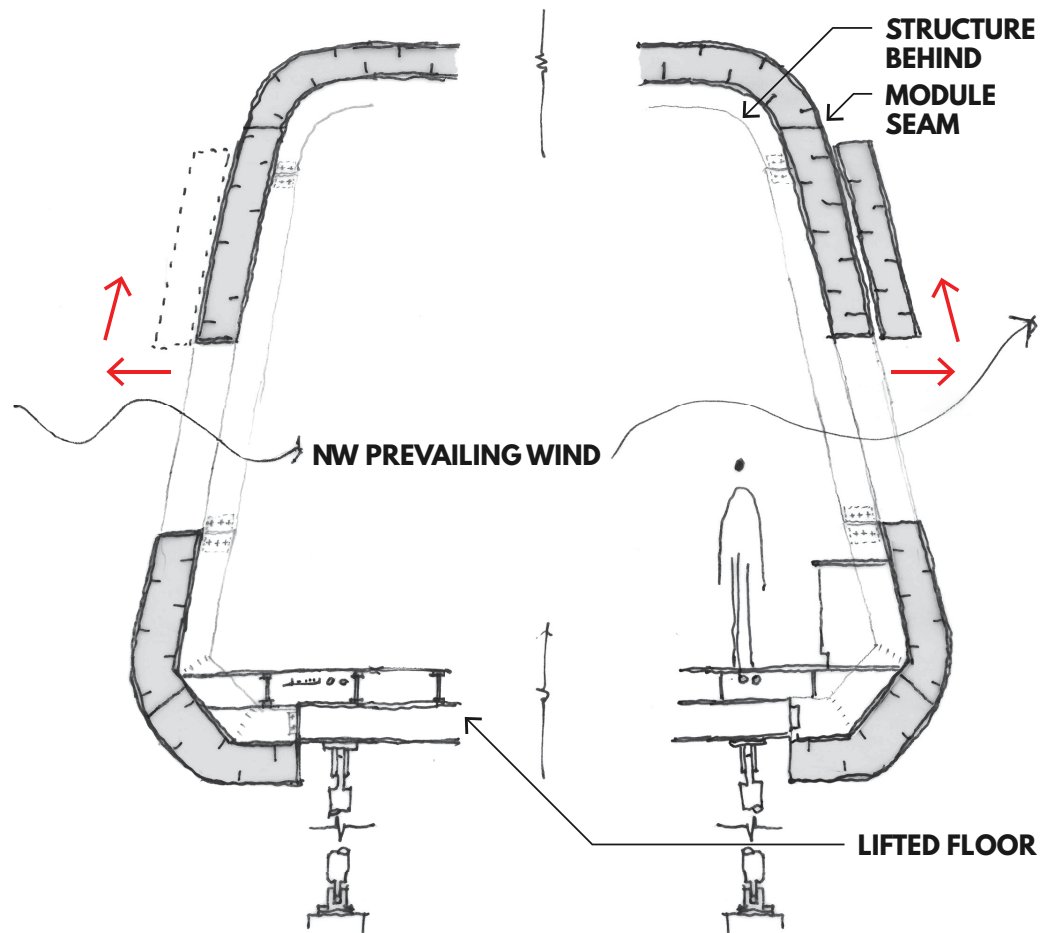

## OPERABLE WALL PANEL

JUNE - AUGUST

During the summer the large semi-conditioned workshop spaces in the building would be active with workers and locals maintaining vehicles and equipment. The activity of machinery, combined the long sun filled days, could result in higher interior temperatures. To prevent this, a cross breeze can be generated by opening wall panels on either side of the building to allow the prevailing wind to cool the space.

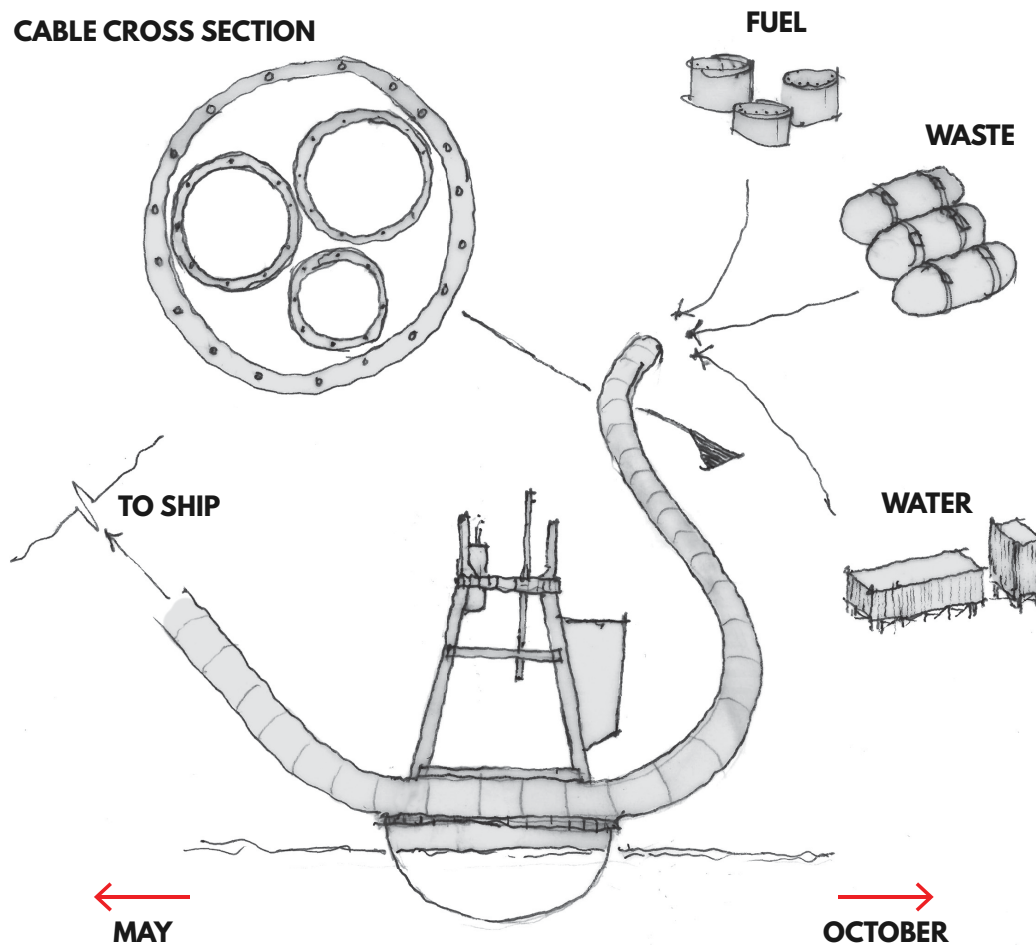

## MARINE RESUPPLY NODE

MAY - OCTOBER

Research has shown that the number of deep draft ships visiting Cambridge Bay and passing through the Northwest Passage will increase. These vessels will require fuel and fresh water, and will also need to deposit waste. The sea floor around Cambridge Bay slopes away gently and dredging near the shore to create a deep draft mooring would be expensive and not often used. For this reason, an off-shore buoy and cable would be used to connecting the visiting vessel to shore services, with passengers tendered to shore with a smaller boat.

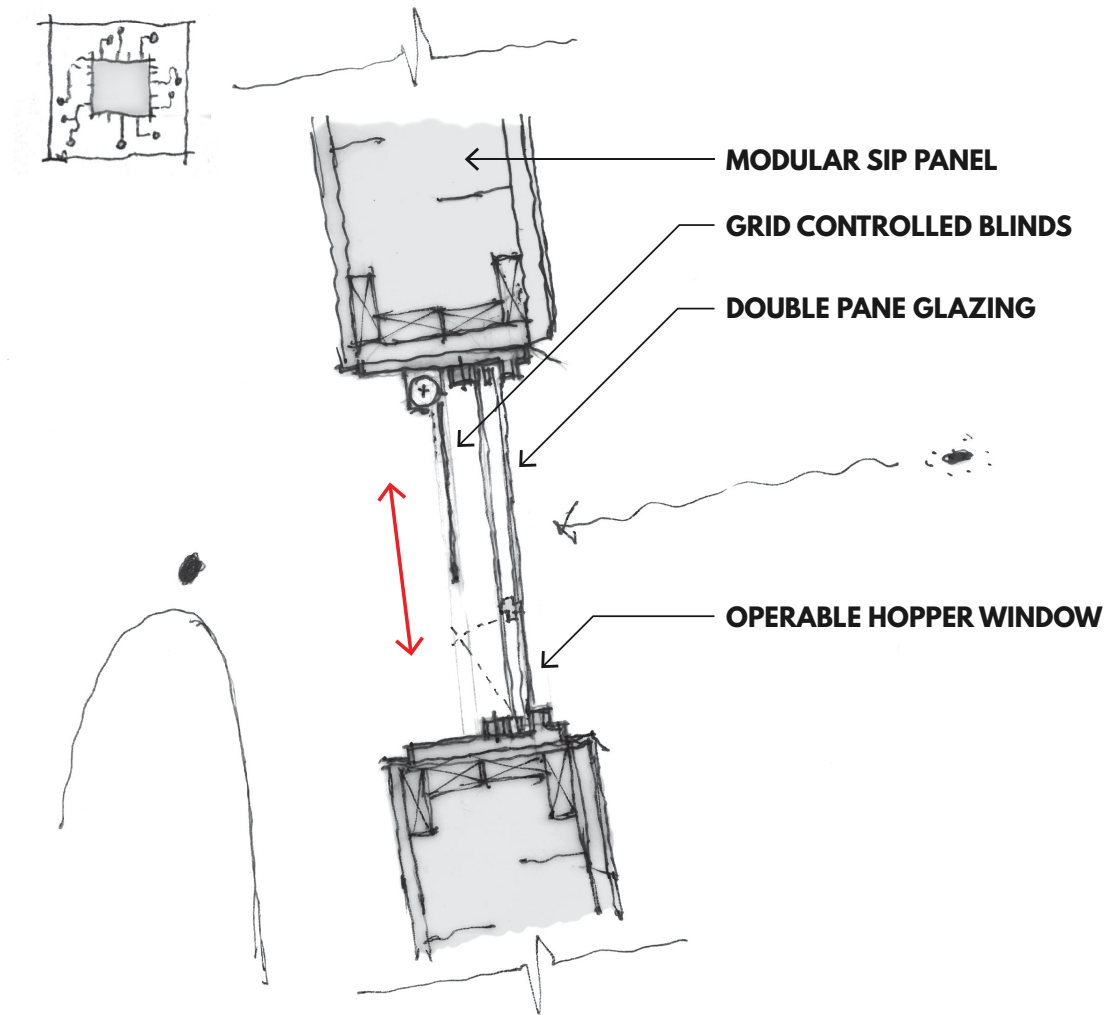

## RETRACTABLE WINDOW SHADING

FEBRUARY - OCTOBER

Building interiors in the Arctic have a tendency to become warm and stuffy in the summer, due to southern-oriented glazing allowing natural light into the space for long periods of time each day. A combination of window shading and operable glazing can prevent this. The shading and operable glazing in the proposed building is controlled by a thermostat, opening and closing elements throughout the day to maintain conditions set by building users.

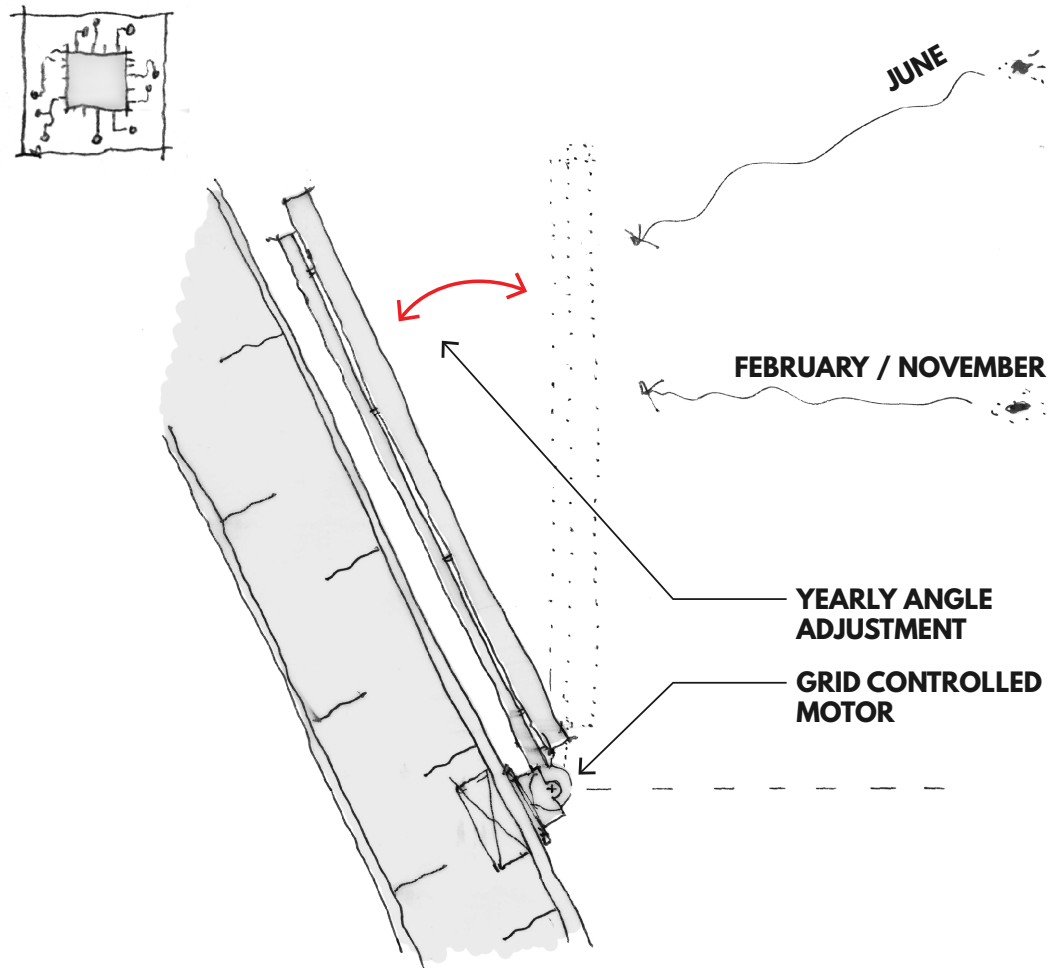

## PHOTOVOLTAIC TILT

JANUARY - NOVEMBER

Photovoltaic panels are a proven way to generate energy in polar regions. Paired with a wind turbine farm and dense energy storage, the system would be able to generate and store power for the building and community. Photovoltaic panels perform optimally when they are set perpendicular to the sun angle. By adjusting the angle of the south-facing panels through the year to track the sun, the greatest amount of energy can be generated.

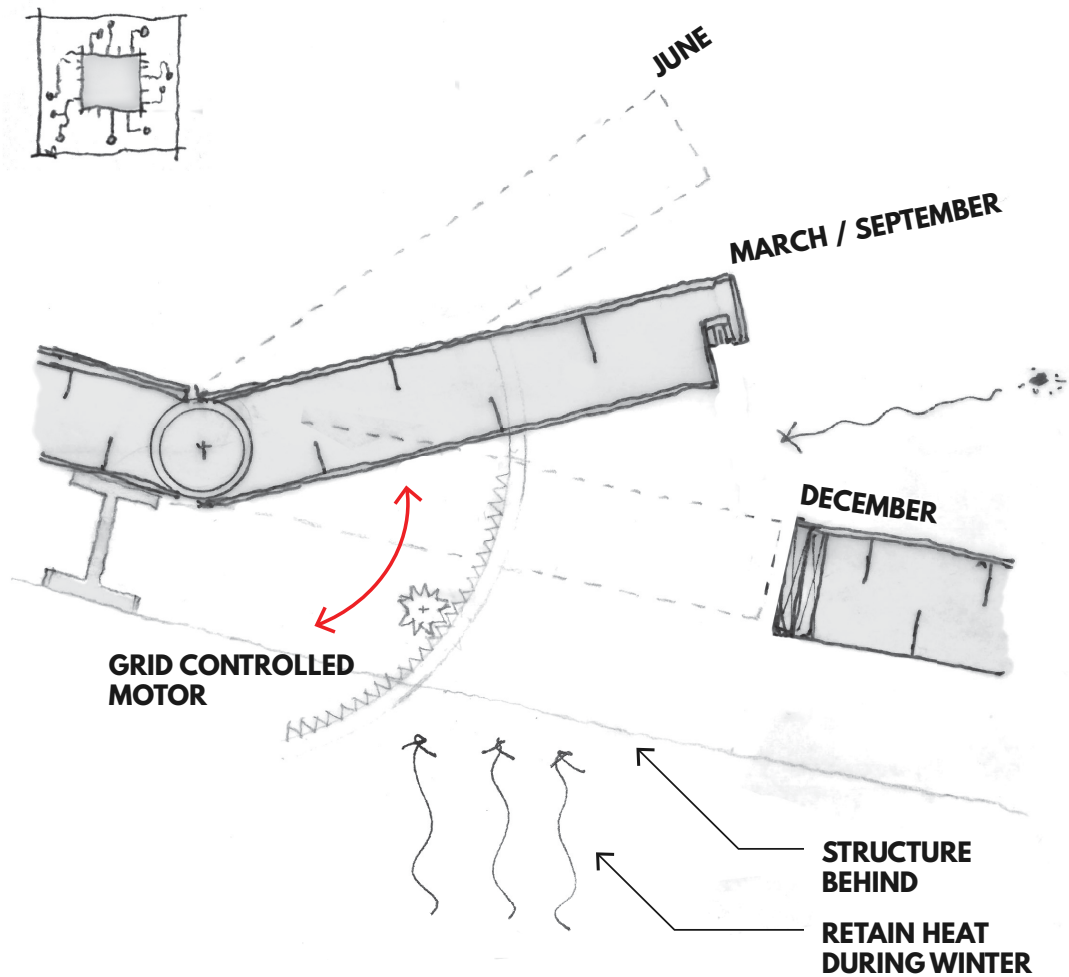

## OPERABLE ROOF PANEL

FEBRUARY - OCTOBER

Opening the roof with skylights allows natural light into the centre of the workshop spaces during the spring, summer, and fall seasons. As with the window shading, the degree of openness is set by users via a thermostat. During the winter, the panels are shut and locked to retain the heat within the space.



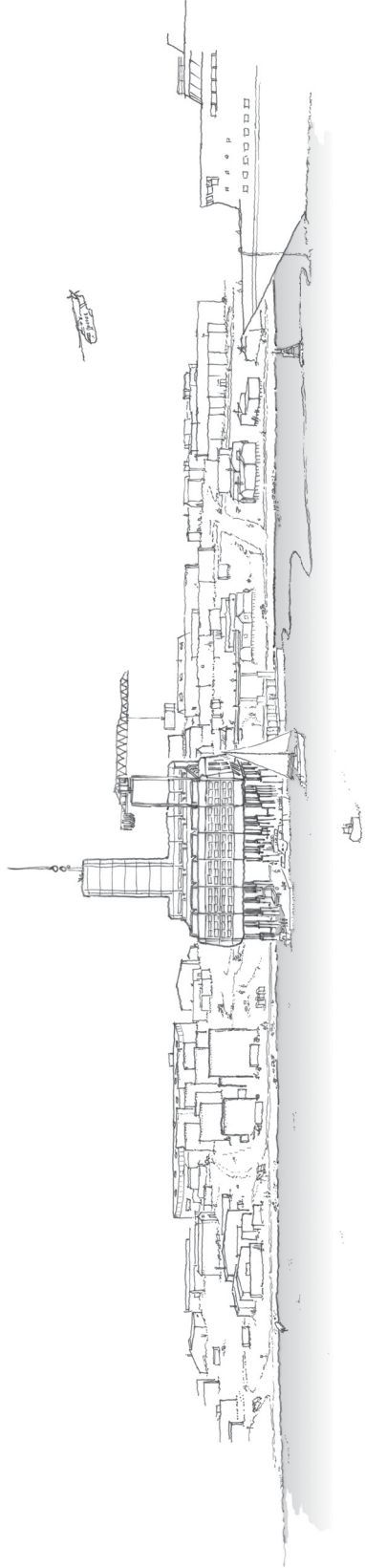

Cambridge Bay shoreline from the bridge of a visiting ship  
User: Tourists / Government; Date: August

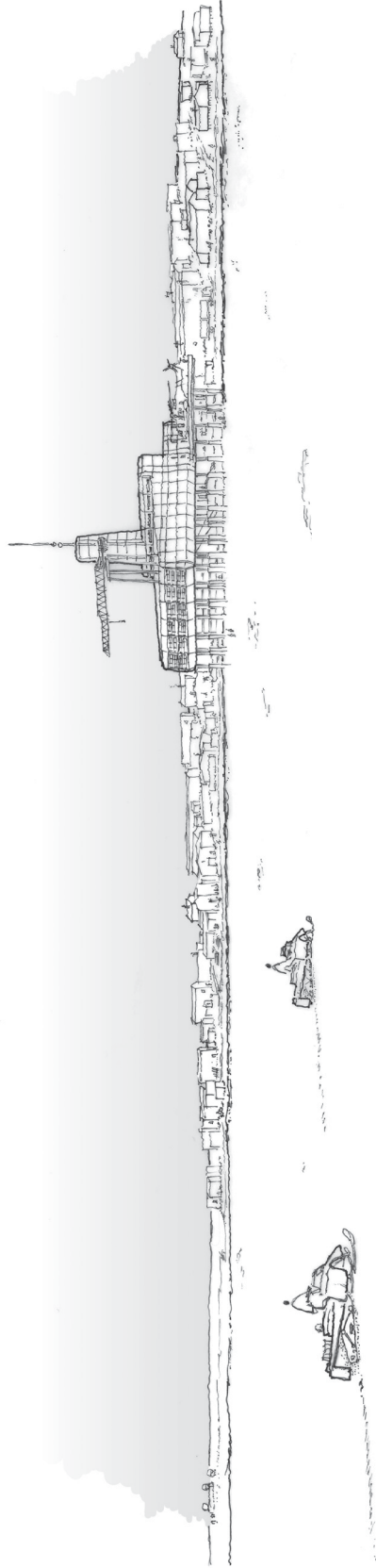

Hunters returning from the ice  
User: Locals; Date: December

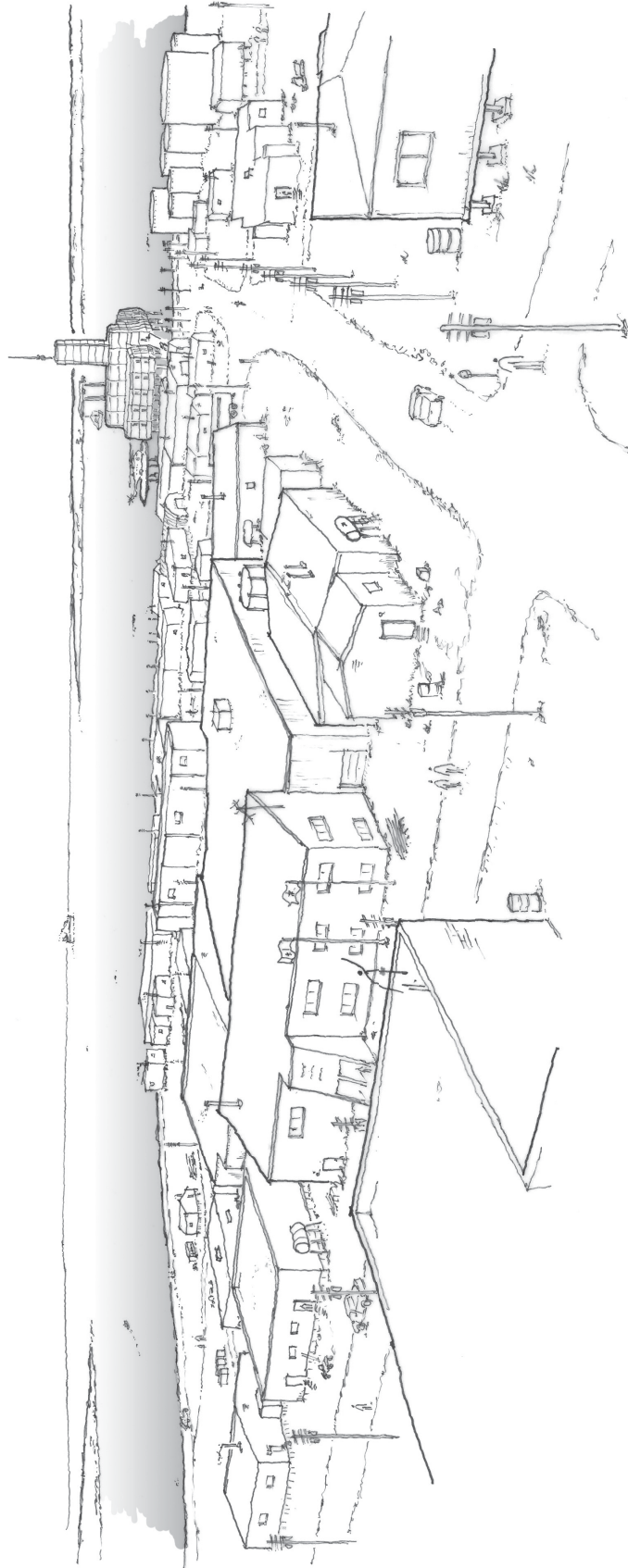

Looking to the shoreline from the downtown axis  
User: Locals; Date: May

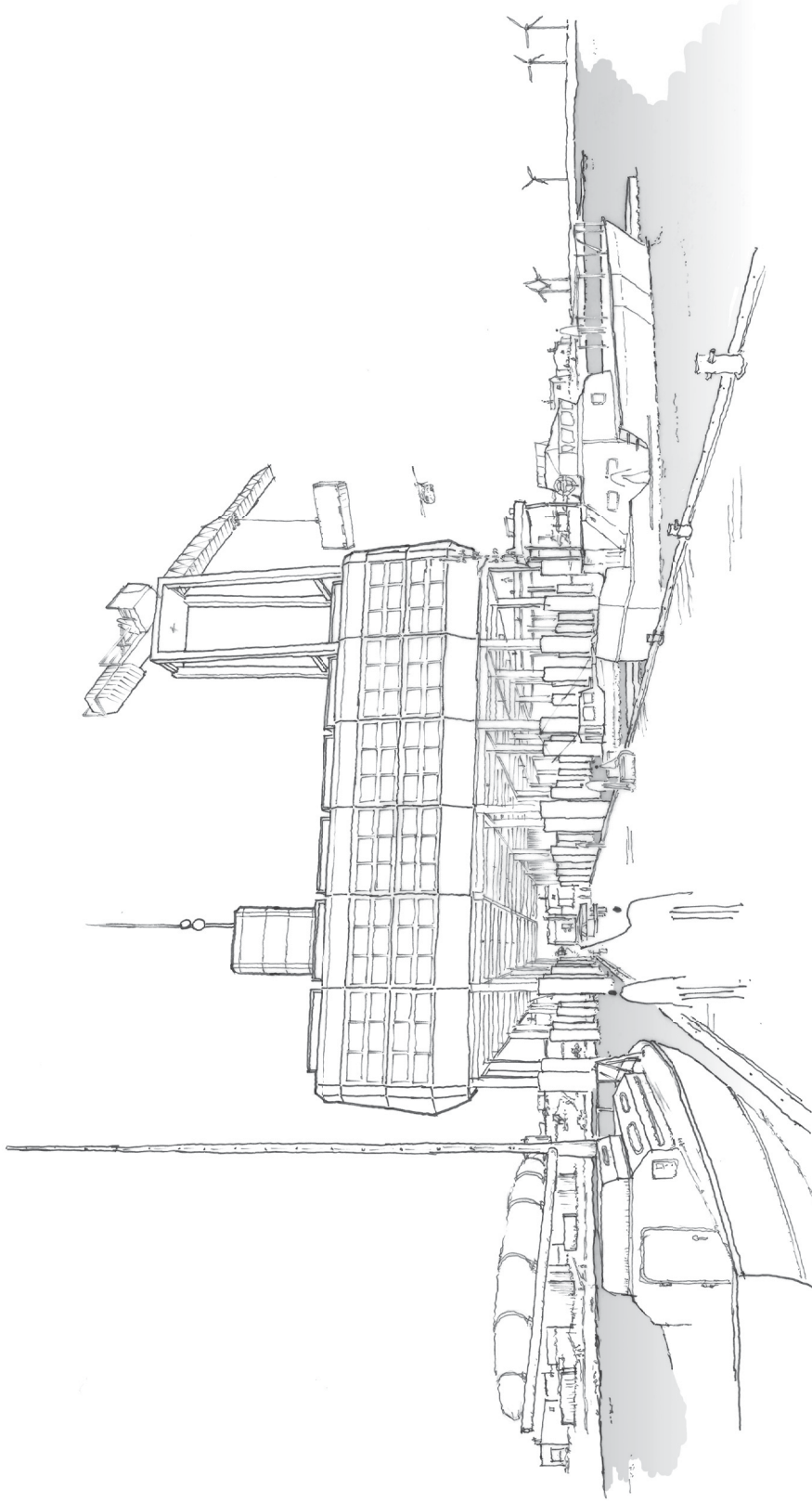

Multiuser activity around the dock  
User: Locals / Tourists / Government; Date: June

## CHAPTER 6: CONCLUSION

How can architecture address risks associated with transportation in the Canadian Arctic while acknowledging Northern geographical and climatic complexities?

The Canadian Arctic is a unique region unlike anywhere else on the North American continent. Seasonal extremes strongly influence the cyclical patterns of all life, and are responsible for moments of dramatic change throughout the year. The local flora and fauna, as well as the lifestyles of traditional and contemporary indigenous people, change throughout the year to suit the conditions. To be static in the Arctic is at best uncomfortable, and at worst fatal.

In the executive summary of the 2017 edition of the *Arctic Report Card*, the National Oceanic and Atmospheric Administration highlights the “pressing need to prepare for and adapt to the New Arctic.”<sup>52</sup> The coining of the phrase *New Arctic* emphasizes how drastic the changes have and will be. To remain static now would be detrimental to the lifestyle of Northern Canadians; the enjoyment and safety of visitors; and Canadian sovereignty in the Arctic. The centre proposed for Cambridge Bay strives to react to seasonal changes just as the local people have done for eons. Eileen Grey talked of creating architecture as “a living organism” serving “the atmosphere required by human life.”<sup>53</sup> A building that physically and programmatic changes

---

52 J. Richter-Menge, J. E. Overland, J. T. Mathis, and E. Osborne, eds., *Arctic Report Card 2017*, 3, [ftp://ftp.oar.noaa.gov/arctic/documents/ArcticReportCard\\_full\\_report2017.pdf](ftp://ftp.oar.noaa.gov/arctic/documents/ArcticReportCard_full_report2017.pdf).

53 Rowan Moore, “Eileen Gray’s E1027: a lost legend of 20th-century architecture is resurrected,” *The Guardian*, May 2, 2015, <https://www.theguardian.com/artanddesign/2015/may/02/eileen-gray-e1027-villa-cote-dazur-reopens-lost-legend-le-corbusier>.

to address climatic externalities is programmatically more effective, benefits user comfort in all seasons, and increases building system efficiency. Due to its remoteness, Northern Canada was historically separated from the mindset of the rest of the country. Economical, political, and environmental decisions were made in the Canadian South, far from the people and areas they affected. The centre's program shifts agency and resources to Northern Canadians, capitalizing on their knowledge of the region, and placing infrastructure directly where it is needed.

Anthropogenic climate change will continue to have numerous significant effects in the Canadian Arctic and will impact every facet of Arctic life. Applying static Southern architectural solutions to dynamic Northern conditions is not sufficient. This thesis addresses the challenges posed by one effect, increased traffic, but also suggests a different way of thinking about architecture, a way that is more Arctic-specific. It is the author's intention that the strategies suggested here will benefit those designing for Arctic conditions, and be expanded upon to address the continually changing Canadian Arctic.

## BIBLIOGRAPHY

- Aarluk Consulting Inc. *Infrastructure for a Sustainable Cambridge Bay*. Vol. 2. February 28, 2011. [http://toolkit.buildingnunavut.com/ICSP/Cambridge%20Bay/Cambridge%20Bay%20ICISP%20Volume%202%20Final%20\(2011-05-18\).pdf](http://toolkit.buildingnunavut.com/ICSP/Cambridge%20Bay/Cambridge%20Bay%20ICISP%20Volume%202%20Final%20(2011-05-18).pdf).
- Arctic Council. *Arctic Marine Shipping Assessment 2009 Report*, Second Printing. Akureyri: Protection of the Arctic Marine Environment, 2009.
- . *Status on Implementation of the Arctic Marine Shipping Assessment 2009 Report Recommendations*. Akureyri: Protection of the Arctic Marine Environment, 2013.
- Arctic Monitoring and Assessment Programme (AMAP). *Arctic Climate Issues 2011: Changes in Arctic Snow, Water, Ice and Permafrost*. Oslo: Arctic Monitoring and Assessment Programme, 2012.
- Arctic Portal Library. "Arctic Search and Rescue Delimitation Map" Accessed January 20, 2019. <http://library.arcticportal.org/1500/>.
- Atkisson, A., T. Arnbom, C. Tesar, and A. Christensen. *Getting it Right in a New Ocean: Bringing Sustainable Blue Economy Principles to the Arctic* (Summary). Ottawa, World Wildlife Foundation Arctic Programme, 2018.
- Bennett, Mia. "MH 370: What if it were to Happen in the Arctic?" Accessed February 6, 2019. <https://www.cryopolitics.com/2014/03/25/mh370-what-if-it-were-to-happen-in-the-arctic/>.
- Carter, N. A., J. Dawson, J. Knopp, J. Joyce, M. Weber, Z. Kochanowicz, and O. Mussells. *Arctic Corridors and Northern Voices: Governing Marine Transportation in the Canadian Arctic*. Ottawa: University of Ottawa, 2018.
- CBC. "B.C. Firm Wins Design Contract for Arctic Naval Port." November 26, 2009. <https://web.archive.org/web/20091130223348/http://www.cbc.ca/canada/north/story/2009/11/26/nanisivik-contract.html>.
- Chauvin, Maude. "Anatomie du mur de Fermont." Accessed October 20, 2018. <https://www.jobboom.com/carriere/anatomie-du-mur-de-fermont/>.
- Clark, Dylan. Senate Committee on Fisheries and Oceans. *Arctic Search and Rescue - Senate Testimony Opening Statement*. February 15, 2018. <http://www.jamesford.ca/archives/5275>.
- Coates, Kenneth, P. Whitney Lackenbauer, William R. Morrison, and Greg Poelzer. *Arctic Front: Defending Canada in the Far North*. Toronto: T. Allen Publishers, 2008.
- Croft, John. "US FAA to End ETOPS Range Restrictions for Qualified Aircraft." Flight Global, (2007). <https://www.flightglobal.com/news/articles/us-faa-to-end-etops-range-restrictions-for-qualified-aircraft-211460/>.

- Davies, John. "RCAF EHI CH-149 Cormorant" Photograph from *Wikipedia*, March 16, 2018. [https://en.wikipedia.org/wiki/AgustaWestland\\_CH-149\\_Cormorant](https://en.wikipedia.org/wiki/AgustaWestland_CH-149_Cormorant).
- Dawson, Jackie, Larissa Pizzolato, Stephen E. L. Howell, Luke Copland, and Margaret E. Johnston. "Temporal and Spatial Patterns of Ship Traffic in the Canadian Arctic from 1990 to 2015." *Arctic* 71, no. 1 (2018): 15-26.
- Elkaim, Aaron V. "Mr. Qisiiq, outside, and Mr. Sakiagak, inside, demonstrated igloo construction techniques." Photograph from "A Lost Art in the Arctic: Igloo Making." *New York Times*, June 21, 2017. <https://www.nytimes.com/2017/06/21/world/canada/igloos-inuit-arctic-canada.html>.
- Encyclopaedia Britannica, The Editors of. "Roald Amundsen." *Encyclopædia Britannica*. Accessed December 2, 2018. <https://www.britannica.com/biography/Roald-Amundsen>.
- FlightAware, "Flight Search." Accessed February 6, 2019. [www.flightaware.com](http://www.flightaware.com).
- Frizzell, Sara. "Remembering the Baffin Island Plane Crash that could have Killed 26, 42 Years Ago Today." *CBC*, November 3, 2017. <https://www.cbc.ca/news/canada/north/plane-crash-1975-nunavut-1.4385869>.
- Government of Canada. "Canadian Rangers Frequently Asked Questions." Accessed March 6, 2019. <http://www.army-armee.forces.gc.ca/en/canadian-rangers/faq.page>.
- Grant, Shelagh D. *Polar Imperative: A History of Arctic Sovereignty in North America*. Vancouver: Douglas & McIntyre, 2010.
- Hassol, Susan J. *Impacts of a Warming Arctic: Arctic Climate Impact Assessment*. Cambridge: Cambridge University Press, 2004.
- Hidden Architecture. "Arctic Town." November 11, 2011. <http://hiddenarchitecture.net/arctic-town/>.
- Ingegneria dei Sistemi. "Canada - Italy: Arctic Science and Technology Collaboration Workshop." Slide presentation at Canada-Italy Workshop on Arctic Science and Technology Collaboration, Ottawa, Canada, October 22, 2014. [http://www.polarcom.gc.ca/sites/default/files/ids\\_arctic.pdf](http://www.polarcom.gc.ca/sites/default/files/ids_arctic.pdf).
- International Polar Foundation. "Passive Building Techniques." Accessed on December 3, 2018. [http://www.antarcticstation.org/station/passive\\_building/](http://www.antarcticstation.org/station/passive_building/).
- . "Princess Elizabeth Antarctica: The First Zero Emission Polar Research Station." April 19, 2013. [http://www.antarcticstation.org/assets/uploads/documents\\_files/brochure\\_pea\\_19\\_04\\_2013\\_web.pdf](http://www.antarcticstation.org/assets/uploads/documents_files/brochure_pea_19_04_2013_web.pdf).
- . "Unloading is always an adventure!" Accessed December 3, 2018. [http://www.antarcticstation.org/multimedia/picture\\_gallery/unloading\\_is\\_always\\_an\\_adventure](http://www.antarcticstation.org/multimedia/picture_gallery/unloading_is_always_an_adventure).

- and Robert, René. “Up on its feet.” Accessed December 3, 2018. [www.antarcticstation.org/multimedia/picture\\_gallery/up\\_on\\_its\\_feet](http://www.antarcticstation.org/multimedia/picture_gallery/up_on_its_feet).
- KAYAK. “Flight Search.” Accessed March 3 2019. [www.kayak.com](http://www.kayak.com).
- Lee, Brian. “Radical Arctic Proposals,” Rice School of Architecture, Spring 2012. Accessed December 18, 2018. <https://estatedocbox.com/Architects/86207810-Radical-arctic-proposals.html>.
- Lennox, E. G. “It’s Time... Search and Rescue IN the Arctic!” *Frontline* 2, no. 5, (2005). <https://defence.frontline.online/article/2005/5/6099>.
- Leroux, J. G. R. “The Arctic SAR Region: Frozen in Time.” Canadian Forces College, 2017. Accessed February 6, 2019. <https://www.cfc.forces.gc.ca/259/290/402/305/leroux.pdf>.
- Leslie, Frank. “The Fate of Sir John Franklin.” *Frank Leslie’s New York Journal* 1-2 (1855). Accessed March 24, 2019. <https://books.google.com/books?id=moFNAAAAYAAJ>.
- Mackay, Mac. “Louis S. St-Laurent.” Photograph from *Shiphax*, December 22, 2011. <http://shipfax.blogspot.com/2011/12/ccgs-louis-s-st-laurent-novadock-to-bio.html>.
- Miller, Mark M. “Walk to the Neighboring settlement of Apex.” Photograph from “My Trip to Nunavut, Canada.” *Mark M. Miller*, August 2010. [http://ocean.otr.usm.edu/~w301497/travels/nunavut/nunavut\\_home\\_2.html](http://ocean.otr.usm.edu/~w301497/travels/nunavut/nunavut_home_2.html).
- Moore, Rowan. “Eileen Gray’s E1027: a lost legend of 20th-century architecture is resurrected.” *The Guardian*, May 2, 2015. <https://www.theguardian.com/artanddesign/2015/may/02/eileen-gray-e1027-villa-cote-dazur-reopens-lost-legend-le-corbusier>.
- Morrison, William R. “Canadian Arctic Sovereignty.” *The Canadian Encyclopedia*. Accessed December 2, 2018. <https://www.thecanadianencyclopedia.ca/en/article/arctic-sovereignty>.
- National Snow and Ice Data Centre. “Sea Ice Index.” Accessed December 2, 2018. [https://nsidc.org/data/seaice\\_index/](https://nsidc.org/data/seaice_index/).
- Natural Resources Canada. *North Circumpolar Region*. Scale 1:9,000,000. “The Atlas of Canada Reference Map Series.” May 30, 2017. [http://ftp.geogratis.gc.ca/pub/nrcan\\_rncan/raster/atlas/eng/reference/circumpolar/MCR0001\\_circumpolar\\_2017.pdf](http://ftp.geogratis.gc.ca/pub/nrcan_rncan/raster/atlas/eng/reference/circumpolar/MCR0001_circumpolar_2017.pdf).
- Ng, H. K., B. Sridhar, S. Grabbe, and N. Chen. “Cross-Polar Aircraft Trajectory Optimization and the Potential Climate Impact,” 30th Digital Avionics Systems Conference (DASC). Seattle, WA: IEEE, October 16-20, 2011. <https://ieeexplore.ieee.org/document/6096216>.
- NSIDC / NASA. “Arctic Sea Ice Minimum.” Accessed December 2, 2018. <https://climate.nasa.gov/vital-signs/arctic-sea-ice/>.



- Parsons, Gordon. "Fermont, Quebec." Photograph from "Fermont, Quebec: Living on the Edge." *Gateway Labrador*. Accessed October 20, 2018. <http://www.gatewaylabrador.ca/our-towns/fermont-quebec>.
- Parsons, James. *Benchmarking of Best Practices for Arctic Shipping*. World Wildlife Foundation, 2012.
- The Pew Charitable Trusts. *The Integrated Arctic Corridors Framework: Planning for Responsible Shipping in Canada's Arctic Waters*, April 2016. <https://www.pewtrusts.org/~media/assets/2016/04/the-integrated-arctic-corridors-framework.pdf>.
- Rae, John. *Frank Leslie's New York Journal*, vol. 1-2. 1855. Accessed March 24, 2019. <https://books.google.ca/books?id=moFNAAAAYAAJ>.
- Richter-Menge, J., Overland, J. E., Mathis, J. T., and Osborne, E., eds. *Arctic Report Card 2017*. November 17, 2017. [ftp://ftp.oar.noaa.gov/arctic/documents/ArcticReportCard\\_full\\_report2017.pdf](ftp://ftp.oar.noaa.gov/arctic/documents/ArcticReportCard_full_report2017.pdf).
- Schmaltz, Jeff / NASA Earth Observatory. "A Nearly Ice-Free Northwest Passage." Accessed November 28, 2018. <https://earthobservatory.nasa.gov/images/88597>.
- Schoenauer, Norbert. "Shape and Orientation of New Buildings Design for Energy Conservation in the Sub-Arctic with Special Reference to Fermont." Paper prepared for the Economic Commission for Europe Committee on Housing, Building and Planning, Ottawa, Canada, May 23 1977.
- . "Townsite of Fermont." From *Norbert Schoenauer Collections*. Accessed December 16, 2018. <http://cac.mcgill.ca/schoenauer/cases/urban-fermont.htm>.
- Sevunts, Levon. "Canadian Coast Guard Wraps Up Busy Arctic Season." *CBC*, October 17, 2017. <http://www.rcinet.ca/eye-on-the-arctic/2017/10/17/canadian-coast-guard-wraps-up-busy-arctic-season/>.
- Sheppard, Adrian. "Fermont: The Making of a New Town in the Canadian Sub-Arctic." March 2012. [https://www.mcgill.ca/architecture/files/architecture/fermont-nov\\_2011-rev.pdf](https://www.mcgill.ca/architecture/files/architecture/fermont-nov_2011-rev.pdf).
- Sheppard, Lola, and White, Mason. *Many Norths: Spatial Practice in a Polar Territory*. New York: Actar Publishers, 2017.
- Statistics Canada. *Population, Dwelling and Households of Canada, Provinces and Territories*. Ottawa, Ontario, 2016.
- World Wildlife Foundation (WWF). *Arctic Shipping Fact Sheet*, (WWF, 2013). [www.awsassets.wwf.ca/downloads/wwf\\_arctic\\_shipping\\_factsheet.pdf](http://www.awsassets.wwf.ca/downloads/wwf_arctic_shipping_factsheet.pdf).
- . "Arctic Climate Change." Accessed January 3, 2019. <https://arcticwwf.org/work/climate/>.