

Studies on Ring Forming Reactions: Geminal Acylation, Nazarov Cyclization and
Cyclohexyne Reactions

by

François M. LeFort

Submitted in partial fulfilment of the requirements
for the degree of Doctor of Philosophy

at

Dalhousie University
Halifax, Nova Scotia
August 2015

© Copyright by François M. LeFort, 2015

Table of Contents

| | |
|--|------|
| List of Tables..... | v |
| List of Figures..... | vi |
| List of Schemes..... | vii |
| Abstract..... | xi |
| List of Abbreviations and Symbols Used..... | xii |
| Acknowledgements..... | xvii |
| Chapter 1 – Introduction..... | 1 |
| Chapter 2 – Exploring the Synthesis of a Propellane via Geminal Acylation..... | 4 |
| 2.1 Introduction to Geminal Acylation..... | 4 |
| 2.2 The Scope and Limitations of the Geminal Acylation..... | 7 |
| 2.2.1 Modification of the Acyloin..... | 7 |
| 2.2.2 Modification of the Substrate..... | 11 |
| 2.2.3 Post Geminal Acylation Modifications..... | 13 |
| 2.3 Natural Product Synthesis Using Geminal Acylation..... | 15 |
| 2.4 My Research Project..... | 19 |
| 2.4.1 Synthesis of a Propellane Using Geminal Acylation..... | 19 |
| 2.4.2 Retrosynthesis..... | 21 |
| 2.5 Results and Discussion..... | 22 |
| 2.6 Conclusions & Future Work..... | 29 |
| 2.7 Experimental..... | 30 |
| 2.7.1 General Considerations..... | 30 |
| 2.7.2 Preparation and Characterization Data..... | 31 |

| | |
|---|-----|
| Chapter 3 – Nazarov Reactions Intercepted by (4+3) Cycloadditions with Oxygen-Substituted Dienes..... | 44 |
| 3.1 Introduction..... | 44 |
| 3.2 The Interrupted Nazarov Reaction..... | 46 |
| 3.3 Nazarov Reactions with Allenyl Vinyl Ketones..... | 47 |
| 3.4 Interrupted Nazarov Reactions of AVKs..... | 49 |
| 3.4.1 Mono-Additions to Oxyallyl π -Systems..... | 49 |
| 3.4.2 Bis-Additions to Oxyallyl π -Systems..... | 53 |
| 3.4.3 Interrupted Nazarov Reactions with Oxygen-Substituted Dienes..... | 55 |
| 3.5 Results and Discussions..... | 56 |
| 3.5.1 Synthesis of the AVKs..... | 56 |
| 3.5.2 Synthesis of Dienes..... | 58 |
| 3.5.3 Interrupted Nazarov Reactions..... | 60 |
| 3.6 Conclusions and Future Work..... | 77 |
| 3.7 Experimental..... | 78 |
| 3.7.1 General Information..... | 78 |
| 3.7.2 Preparation and Characterization Data..... | 80 |
| Chapter 4 – The Study of Cyclohexyne..... | 115 |
| 4.1 Introduction..... | 115 |
| 4.2 Metal Complexes of Cyclohexyne..... | 120 |
| 4.3 Applications of Cyclohexyne in Total Synthesis..... | 122 |
| 4.4 Results and Discussion..... | 126 |
| 4.4.1 Introduction..... | 126 |
| 4.4.2 Diels-Alder Reactions of Cyclohexyne 144 | 126 |
| 4.4.3 Diels-Alder Reactions of a Substituted Cyclohexyne..... | 132 |
| 4.4.4 Tetramerization of Cyclohexyne..... | 142 |

| | | |
|-------------|--|-----|
| 4.5 | Conclusions and Future Work..... | 148 |
| 4.6 | Experimental | 149 |
| 4.6.1 | General Information | 149 |
| 4.6.2 | Preparation and Characterization Data..... | 150 |
| Chapter 5 | – Conclusions and Future Directions..... | 175 |
| References | | 179 |
| Appendix A: | ^1H and ^{13}C NMR Spectra for Chapter 2 | 189 |
| Appendix B: | ^1H and ^{13}C NMR Spectra for Chapter 3 | 202 |
| Appendix C: | ^1H and ^{13}C NMR Spectra for Chapter 4 | 277 |

List of Tables

| | |
|--|-----|
| Table 1. The geminal acylation of acetals with 2 and 15 | 11 |
| Table 2. Geminal acylation of substituted ketones | 12 |
| Table 3. Preparation of TMSO-substituted dienes 100a-d | 58 |
| Table 4. Preparation of TBSO-substituted dienes 101a-i | 59 |
| Table 5. Ring-expanded cyclic ketones | 119 |
| Table 6. Reactions of cyclohexyne with dienes | 130 |
| Table 7. The 1,4-reduction of 178 and the trapping of its enolate | 139 |

List of Figures

| | |
|--|-----|
| Figure 1. Example of a [4.4.4]propellane | 2 |
| Figure 2. Acyloin 15 | 10 |
| Figure 3. Sesquiterpenes made by geminal acylation | 16 |
| Figure 4. Modhephene | 20 |
| Figure 5. Potential trapping sites of an oxyallyl cation..... | 49 |
| Figure 6. Type 1, Type 2, and Type 3 AVKs..... | 56 |
| Figure 7. Stereochemical assignments of Nazarov products using NOE..... | 63 |
| Figure 8. ORTEP of 111 | 66 |
| Figure 9. ORTEP of 116 | 67 |
| Figure 10. Thiophenes and thiazole to be tested as nucleophiles | 78 |
| Figure 11. Batrachotoxin..... | 124 |
| Figure 12. Alkyl-substituted cyclohexynes..... | 134 |
| Figure 13. Transition state geometries of the diastereoselective Diels-Alder reaction. | 142 |
| Figure 14. ORTEP of tetramer 180 | 146 |

List of Schemes

| | |
|---|----|
| Scheme 1 - The geminal acylation reaction | 5 |
| Scheme 2. The synthetic utility of 1,3-diketones | 5 |
| Scheme 3. The “reductive succinoylation” reaction | 6 |
| Scheme 4. A) Geminal acylation with a five-membered acyloin. B) The formation of a 1,2-diketone | 8 |
| Scheme 5. The stereoselectivity of 10 | 9 |
| Scheme 6. A) Byproducts of the geminal acylation reaction with 12 . B) The improved geminal acylation reaction of ketones with 12 | 10 |
| Scheme 7. The geminal acylation of a 2-methoxyoxazolidine | 13 |
| Scheme 8. The synthesis of a trichothecane analog | 14 |
| Scheme 9. Further manipulation of geminal acylation products 23 and 26 | 15 |
| Scheme 10. A) Synthons prepared for the synthesis of 32 . B) Wendt's geminal acylation step. C) Parker's geminal acylation key step. D) Morrison's geminal acylation key step and core synthon | 17 |
| Scheme 11. The total synthesis of (–)-chokol G 45 | 19 |
| Scheme 12. Retrosynthesis of a [4.n.3]-propellane..... | 21 |
| Scheme 13. Acyloin condensation using TMSCl as the trapping agent | 22 |
| Scheme 14. Attempted synthesis of a ketodiester | 23 |
| Scheme 15. Acid-catalyzed ring-opening of a 1,3-diketone | 24 |
| Scheme 16. Initial attempts at the geminal acylation of 61 | 25 |
| Scheme 17. A new method for the generation of a ketodiester then its protection..... | 26 |
| Scheme 18. Attempted transesterifications | 27 |
| Scheme 19. Synthesis of the unmethylated ketodiester | 28 |
| Scheme 20. Future attempt toward the synthesis of 76 | 30 |
| Scheme 21. The Nazarov reaction | 44 |

| | |
|---|-----|
| Scheme 22. Diastereospecificity of 4π electrocyclization | 45 |
| Scheme 23. The major conformations of divinyl ketones..... | 46 |
| Scheme 24. An interrupted Nazarov reaction with an alkene. ⁸⁴ | 47 |
| Scheme 25. The silica gel-mediated Nazarov cyclization of an AVK..... | 48 |
| Scheme 26. The resonance contributors of oxyallyl cation intermediates..... | 48 |
| Scheme 27. An interrupted Nazarov reaction with TFA..... | 50 |
| Scheme 28. Interrupted Nazarov reactions using halogen nucleophiles..... | 51 |
| Scheme 29. Interrupted Nazarov reactions with <i>N</i> -substituted pyrroles..... | 52 |
| Scheme 30. Interrupted Nazarov reactions with cyclic dienes | 52 |
| Scheme 31. Nazarov cyclization with an ambiphilic molecule | 53 |
| Scheme 32. Interrupted Nazarov reactions with acyclic dienes..... | 54 |
| Scheme 33. (4+3) Cycloadditions with 2,3-dimethylbutadiene..... | 55 |
| Scheme 34. Synthesis of AVKs | 57 |
| Scheme 35. Preparation of 101j | 60 |
| Scheme 36. Formation of (4+3) cycloadducts using 100a-c | 62 |
| Scheme 37. Nazarov reactions of AVK 80 in the presence of dienes 101a-d and 101j . 64 | |
| Scheme 38. Nazarov reactions of AVK 80 in the presence of dienes 101e-i | 68 |
| Scheme 39. Nazarov reactions with AVKs 93 and 95 | 70 |
| Scheme 40. Possible mechanisms for the formation of 106 | 71 |
| Scheme 41. Acid treatment of 116 , 109a,b and 111 | 72 |
| Scheme 42. Acid treatment of 120 and 121 | 73 |
| Scheme 43. Compact and extended transition states of the (4+3) cycloaddition..... | 74 |
| Scheme 44. The transition states of (4+3) cycloadditions with the oxyallyl cations from AVKs 93 and 95 | 76 |
| Scheme 45. Putative formation of 144 in the elimination-addition reaction of 145 | 116 |

| | |
|---|-----|
| Scheme 46. The (2+2) addition of an enolate to a cyclohexyne derivative and ring expansion of the product..... | 116 |
| Scheme 47. (4+2) Cycloaddition of an α -pyrone to cyclohexyne..... | 117 |
| Scheme 48. The generation and trapping of cyclohexyne from iodonium salt 152 | 118 |
| Scheme 49. Cyclohexyne complexes with platinum..... | 120 |
| Scheme 50. Reactions of organometallic complexes of cyclohexyne | 122 |
| Scheme 51. Retrosynthesis of guanacastepenes N and O..... | 123 |
| Scheme 52. The cycloinsertion of cyclohexyne in the total synthesis of guanacastepenes N and O | 124 |
| Scheme 53. Synthesis of batrachotoxin core structures | 125 |
| Scheme 54. Preparation of cyclohexyne precursor 148 | 127 |
| Scheme 55. A) Trimerization of cyclohexyne. B) Tetramerization of cyclohexyne. C) Distannylation of cyclohexyne. D) Acyl-alkylation of cyclohexyne..... | 129 |
| Scheme 56. Generating cyclohexyne using TBAF | 132 |
| Scheme 57. (3+2) Reaction of 193 with benzyl azide | 133 |
| Scheme 58. Retrosynthesis of substituted cyclohexynes 193 , 194 , and 195 | 134 |
| Scheme 59. Attempts at preparing methylated cyclohexynes from 2-cyclohexenones | 135 |
| Scheme 60. Attempts at forming methyl-substituted cyclohexyne precursors | 137 |
| Scheme 61. The preparation of methyl-substituted cyclohexyne precursor 219 | 138 |
| Scheme 62. Attempts at generating a dimethyl-substituted cyclohexyne precursor..... | 140 |
| Scheme 63. Diastereoselective Diels-Alder of a methyl-substituted cyclohexyne..... | 141 |
| Scheme 64. Mechanism proposed by Wittig for the formation of tetramer 180 and trimer 179 | 143 |
| Scheme 65. Generating cyclohexyne from a halogenated cyclohexene triflate..... | 144 |
| Scheme 66. Results of the generation of cyclohexyne from bromocyclohexene triflate 233 | 144 |
| Scheme 67. The generation of cyclohexyne from iodocyclohexene triflate 236 | 145 |

| | |
|---|-----|
| Scheme 68. The attempted generation of cyclohexyne from chlorocyclohexene triflate 238 | 145 |
| Scheme 69. Computationally derived mechanism for the formation of tetramer 180 .. | 147 |
| Scheme 70. Alternative method for generating 73 | 176 |
| Scheme 71. Proposed route to forming trisubstituted cyclohexyne precursor 200 and the retrosynthesis of a chiral cyclohexyne | 178 |

Abstract

Geminal acylation is a powerful tool for converting ketones into 1,3-diketones. An ambitious synthesis of a propellane was envisaged by three geminal acylation reactions. Geminal acylations were done on the ethylene glycol ketal of ethyl levulinate with four- and five-membered acyloins, generating, following a ring-opening process, a series of ketodiester. A methyl substituent appeared to sterically inhibit the subsequent geminal acylation under many different reaction conditions and with different ester moieties. Thus, an unmethylated analog was prepared, but, unfortunately, the geminal acylation of that substrate was also unsuccessful.

Nazarov reactions of allenyl vinyl ketones (AVKs) can be interrupted by the addition of a nucleophile to the reaction mixture. The oxyallyl cations of AVKs were intercepted with a wide variety of oxygen-substituted dienes by (4+3) cycloaddition with a high degree of regioselectivity and with very high facial selectivity. Dienes with a substituent on the terminus of the oxygenated double bond formed (4+3) products in greater than 95% yield, but with modest diastereoselectivities, whereas dienes with a substituent on the terminus of the other double bond formed (4+3) products in modest yield but with high diastereoselectivity. The results were most consistent with a mechanism for the cycloaddition that is concerted but asynchronous.

Cyclohexyne is so strained that it cannot be isolated, but it can be generated and reacted *in situ* with nucleophiles. Cyclohexyne has been studied very little and not much is known about its ability to undergo Diels-Alder reactions. Diels-Alder products were produced from the reactions of cyclohexyne with furan, an oxygenated acyclic diene, and a carbocyclic diene. 3-Methylcyclohexyne was prepared, and it reacted with furan forming diastereomeric adducts in a 2:1 ratio. Attempts were made to generate 3,3-dimethylcyclohexyne, but difficulties in methylation prevented its formation. The Diels-Alder reactions were generally low yielding. Tetramerization of cyclohexyne was a dominant reaction pathway, and the tetramer was obtained as a single diastereomer in 80% yield by a novel method.

List of Abbreviations and Symbols Used

| | |
|---------------------|--|
| Δ | heat |
| ΔG^\ddagger | Gibbs energy of activation |
| δ | chemical shift |
| ν | wavenumber(s) |
| \AA | angstrom |
| Ac | acetyl |
| APCI | atmospheric-pressure chemical ionization |
| aq | aqueous |
| AVK | allenyl vinyl ketone |
| Boc | <i>tert</i> -butyloxycarbonyl |
| Bn | benzyl |
| bp | boiling point |
| br | broad |
| <i>n</i> Bu | <i>n</i> -butyl |
| <i>t</i> Bu | <i>tert</i> -butyl |
| calcd. | calculated |
| COD | 1,5-cyclooctadiene |
| conc. | concentrated |

| | |
|-----------|------------------------------------|
| COSY | correlation spectroscopy |
| Cy | cyclohexyl |
| d | doublet |
| dd | doublet of doublets |
| DBU | 1,8-diazabicyclo[5.4.0]undec-7-ene |
| DCM | dichloromethane |
| dcpe | bis(dicyclohexylphosphino)ethane |
| Diphos | bis(diphenylphosphino)ethane |
| DMAD | dimethyl acetylenedicarboxylate |
| DMAP | 4-(dimethylamino)pyridine |
| DME | 1,2-dimethoxyethane |
| DMF | dimethylformamide |
| DMP | Dess-Martin periodinane |
| DMS | dimethylsulfide |
| dppe | see Diphos |
| <i>dr</i> | diastereomeric ratio |
| equiv. | equivalent(s) |
| ESI | electrospray ionization |
| Et | ethyl |

| | |
|---------------|---|
| g | gram(s) |
| h | hour(s) |
| HMBC | heteronuclear multiple bond correlation (spectroscopy) |
| HOMO | highest occupied molecular orbital |
| HRMS | high-resolution mass spectrometry |
| HSQC | heteronuclear single quantum correlation (spectroscopy) |
| h ν | light energy |
| Hz | hertz |
| IR | infrared |
| <i>J</i> | coupling constant |
| kcal | kilocalorie(s) |
| KHMDS | potassium hexamethyldisilazide |
| K-Selectride | potassium tri- <i>sec</i> -butylborohydride |
| LDA | lithium diisopropylamide |
| LiICA | lithium cyclohexylisopropylamide |
| L-Selectride | lithium tri- <i>sec</i> -butylborohydride |
| LS-Selectride | lithium trisiamylborohydride |
| LUMO | lowest unoccupied molecular orbital |
| M | molar |
| m | multiplet |

| | |
|--------------|--|
| Me | methyl |
| mg | milligram(s) |
| MHz | megahertz |
| min | minute(s) |
| mL | millilitre(s) |
| mmol | milimole(s) |
| mol | mole(s) |
| MOM | methoxymethyl |
| mp | melting point |
| Ms | methanesulfonyl |
| nm | nanometer(s) |
| NMR | nuclear magnetic resonance |
| NOE | nuclear Overhauser effect |
| N-Selectride | sodium tri- <i>sec</i> -butylborohydride |
| Nu | nucleophile |
| ORTEP | Oak Ridge thermal ellipsoid plot |
| <i>i</i> Pr | isopropyl |
| Ph | phenyl |
| ppm | parts per million |
| pTSA | <i>para</i> -toluenesulfonic acid |

| | |
|---------------|---|
| q | quartet |
| rt | room temperature |
| s | singlet |
| t | triplet |
| TBAF | tetrabutylammonium fluoride |
| TBATB | tetrabutylammonium tribromide |
| TFA | trifluoroacetic acid |
| TBS | <i>tert</i> -butyldimethylsilyl |
| TBSOTf | <i>tert</i> -butyldimethylsilyl trifluoromethanesulfonate |
| Tf | trifluoromethanesulfonyl |
| THF | tetrahydrofuran |
| TLC | thin layer chromatography |
| TMEDA | <i>N,N,N',N'</i> -tetramethylethylenediamine |
| TMOF | trimethyl orthoformate |
| TMS | trimethylsilyl |
| <i>t</i> OcNC | <i>tert</i> -octyl isocyanide |
| TOF | time of flight |
| Ts | <i>para</i> -toluenesulfonyl |
| UV | ultraviolet |
| xs | excess |

Acknowledgements

Reflecting on my time at Dalhousie, it seems difficult to come up with every single person who has influenced me and who has made nine years at this institution some of the most memorable years of my life.

Firstly, I would like to thank my supervisor and mentor, Dr. Jean Burnell. I don't think I ever missed any of his 8:30 AM organic chemistry classes, despite being a night owl (and this was long before I started drinking 2-3 cups of coffee per day). Dr. Burnell has taught me a great deal about chemistry and about life. I would like to thank him for bringing me into his lab as an undergraduate to work on an honours project, for then accepting me as a graduate student, and for allowing me to stay an extra couple of years for a PhD. These past five years have been the best years of my life and they will never be forgotten. I would also like to thank my committee members, Dr. Norman Schepp, Dr. Robert White and Dr. Mark Stradiotto. They have all played a significant role during my stay at Dal.

I have had the absolute pleasure of working alongside some great graduate students who have taught me many things and whose friendships I value dearly. They are Dr. Vanessa Marx, Dr. Jonathan Moulins, Tim Morgan, Craig Stamp, Mariam Zaky, Luc LeBlanc, Stephen Driscoll and Dr. Zhe Li. I've also had the pleasure of mentoring some undergraduate students who've contributed to my research projects, Graham Dexter, Vinayak Mishra, and Emily Murrell; thank you for the work that you've done. I am also grateful for the opportunity to have worked

with some other undergraduate students, Owen Chauhan, Giselle Ardagh, Hunter Warden, Lauren Doyle, Scott Panther and Matt Adams.

I would also like to acknowledge Dr. Mike Lumsden for his NMR expertise, Mr. Xiao Feng for running high-resolution mass spectra, and Dr. T. Stanley Cameron for providing X-ray crystal structures. I am grateful to the financial assistance that was provided by Dr. Burnell, the Department of Chemistry, Dalhousie University, and NSERC.

I would like to thank all the new friends I have made along the way; it would not have been easy without them. Special thanks to Ben Tardiff, Andrew Robertson, Jon Moulins, Tim Morgan, Jennifer Melanson, Travis Lundrigan, John Camardese and Paul Duchesne for all the helpful discussions and for the late nights. I am also grateful for my parents, Angus and Carmel, who have helped me financially, emotionally and who have done everything they can to help me achieve my goals. My sisters H el ene and Catherine have helped me along the way.

Most importantly, thank you to my wife Stacey for always being there for me, for putting up with my long hours away, and for keeping me sane. I am incredibly fortunate to spend the rest of my life with her, and I am excited to see where the future will bring us as we move into a new chapter in our lives.

Chapter 1 – Introduction

Organic chemistry began as the study of the chemistry of life, then the study of carbon compounds, especially those related to coal, but now it encompasses both, including all that is carbon-based, along with other elements that are found in living organisms.¹ From methane to enzymes, from Earth to outer space, and from living organisms to materials that improve our daily lives, organic chemicals are all around us. Organic chemists have been synthesizing and characterizing chemicals produced in nature since Wöhler's synthesis of urea in 1828.² Organic chemists around the globe have spent years dedicated to studying biologically active compounds (e.g. drugs, pesticides, natural products), materials of commercial importance (e.g. dyes, clothing fabric, oils), and other carbon-containing molecules. Some of these important chemicals are produced in abundance naturally and may not require synthesis, although you'll likely find chemists who have prepared them synthetically, usually to confirm the molecular geometry or to highlight useful chemical transformations.

Organic synthesis is split into two subcategories. The first is total synthesis, which is the preparation of a target molecule, whether biologically interesting, materials sciences interesting, or theoretically interesting. The second is methodology, which is the investigation of chemical transformations to develop reagents, catalysts, or synthetic strategies, but ultimately methodology helps us to understand how chemical reactions work.³

The following three chapters will highlight three research projects that I have undertaken during the course of my PhD studies. These three studies are diverse and do not have many similarities, other than the fact they involve the formation of cyclic products, though by very different mechanisms.

The first project explores cyclic reactions in the hope of creating an interesting molecular scaffold, a propellane, from geminal acylation reactions (see Chapter 2). The term propellane refers to a tricyclic system conjoined by a carbon-carbon single bond, creating a molecule that resembles a propeller (Figure 1). Propellanes were first synthesized in the 1930s by Diels-Alder cycloadditions,⁴ but the term propellane was only introduced in the literature in 1966.⁵

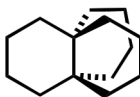

Figure 1. Example of a [4.4.4]propellane.

The second project pertained to mechanistic insights on regio- and diastereoselectivities of a (4+3) cycloadditions of allenyl vinyl ketones and oxygen-substituted dienes in interrupted Nazarov reactions, a tandem process involving electrocyclization and cycloaddition (see Chapter 3). Electrocyclizations are appealing in synthesis because they generate rings from acyclic molecules, creating two new sp^3 hybridized centers along with a new σ bond while losing a π bond.⁶ The interrupted Nazarov reaction can then introduce new carbon-carbon bonds to the product of electrocyclization, which, if done with a high degree of stereocontrol, would be a powerful method of generating complex ring systems.

The third and final project involved the study of cyclohexyne, a strained cycloalkyne, and the desire of improving its synthetic utility, as well as better understanding its limitations as an electrophilic dienophile in Diels-Alder reactions (see Chapter 4). Although arynes, particularly benzyne, have evolved as powerful tools in organic synthesis, cyclohexyne has not been used in synthesis until recently.⁷ Cyclohexyne has been used in a very limited number of examples undergoing (2+2), (3+2) and (4+2)-cycloadditions, although the stereoselectivity of the latter had not been studied. This study also covered a new methodology under development that was aimed at generating substituted cyclohexynes, both for the purpose of examining their stereoselectivity with unsymmetrical dienes in Diels-Alder reactions, and also to substitute the cyclohexyne in an effort to extend its synthetic utility.

Chapter 2 – Exploring the Synthesis of a Propellane via Geminal Acylation

2.1 Introduction to Geminal Acylation

Geminal acylation is the net replacement of a carbonyl group (or equivalent) by two geminal acyl groups. Up until the mid-70's, there were no efficient processes for carrying out this transformation, but in 1977 Eiichi Nakamura and Isao Kuwajima reported a two-step process they termed geminal acylation.⁸ They prepared geminally acylated products from benzaldehyde, acetals and ketals by first forming a pinacol intermediate (**1**) via an acid catalyzed Mukaiyama aldol-type addition of a bis-silylated succinoin (**2**). This was achieved using TiCl_4 , tetrabutylammonium fluoride (TBAF) for benzaldehyde derivatives, or $\text{BF}_3 \cdot \text{OEt}_2$ for acetal and ketal derivatives (Scheme 1). 1,3-Cyclopentanediones (**3**) were then obtained by way of a trifluoroacetic acid (TFA) mediated pinacol rearrangement, which was a concerted process presumably aided by the release of ring strain of the cyclobutanone. This method of forming geminally disubstituted 1,3-cyclopentanediones in two steps made these molecules, and derivatives thereof, much easier to access, and this provided an improved method for syntheses of natural products that contain these core structures.⁹

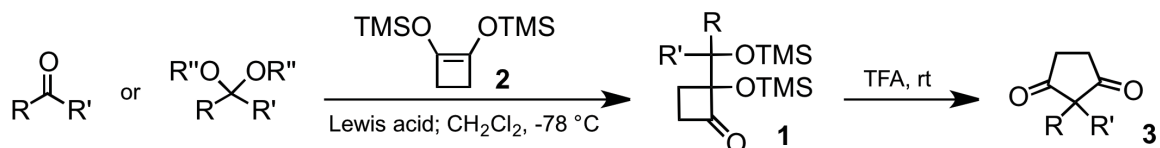

Scheme 1 - The geminal acylation reaction.

They observed that acetals and ketals reacted more efficiently with **2** compared to their carbonyl counterparts, as indicated by higher yields of **1** and comparable yields for the second step. The synthetic utility of this process was highlighted by the formation of 2,2-disubstituted cyclopentanones, including spiro[4.n]alkanes such as **4**, which could then be fragmented and reduced to form a lactone **5**. Functionalization prior to the pinacol rearrangement was possible, as in the formation of **6** (Scheme 2).⁸

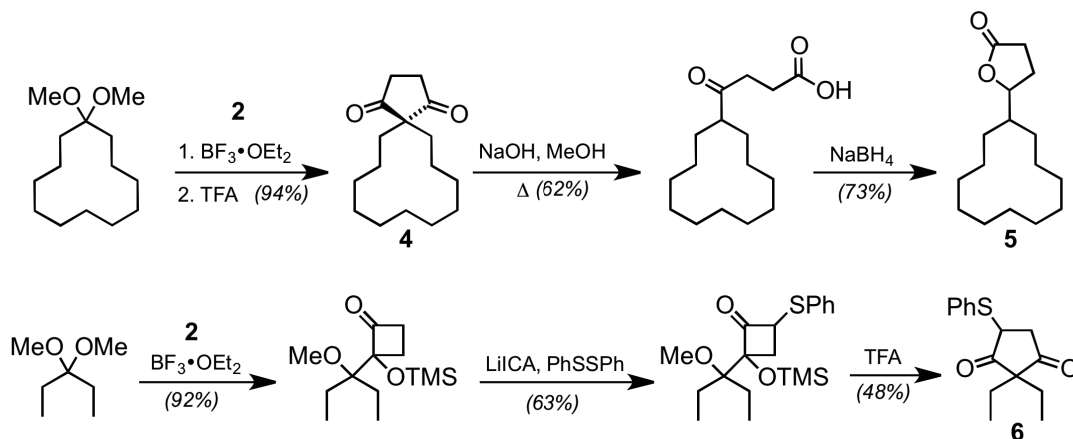

Scheme 2. The synthetic utility of 1,3-diketones.

Kuwajima and coworkers reported the “reductive succinylation” via the intermediate cyclobutanone, forming silyl enol ethers of γ -keto esters (**7**), adding

another facet to this methodology.¹⁰ The preparation of such products was achieved as a result of screening various Lewis acids. SnCl₄ proved to be effective for both the initial aldol step and the subsequent ring-opening step (Scheme 3). The silyl enol ether moiety of **7** could then be used as a nucleophile for a Mukaiyama aldol-type addition or may be hydrolyzed to form a γ -keto ester.^{10,11}

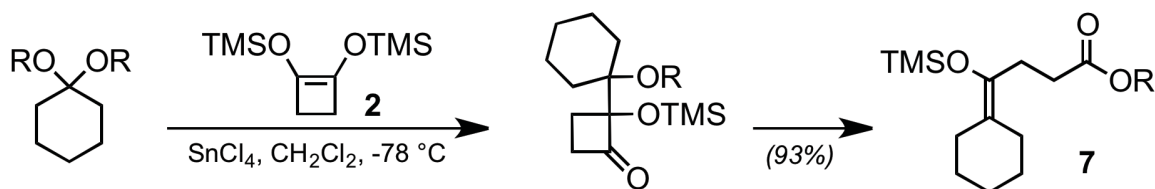

Scheme 3. The “reductive succinylation” reaction.

This geminal acylation process was improved upon in 1988 when Wu and Burnell showed that both the aldol reaction and the pinacol rearrangement could be mediated by the use of excess BF₃•OEt₂ in a one-pot synthesis.¹² This new protocol generally worked better for ketals and benzylic acetals as it gave higher yields than the previous two-step method, it gave cleaner products, and it eliminated the need to work-up the intermediate pinacol.¹² Ketones appeared to be unreactive toward silyl enol ethers however, careful experimentation showed that the initial aldol-like reaction did take place, but the pinacol intermediate underwent a retro-aldol reversion to starting material. This problem was overcome using a one-pot procedure, facilitated by the addition of a small amount of water after forming the pinacol.¹³ The geminal acylation of aldehydes and acetals was also improved by Martinez *et al.* by adding Nafion-H as an acidic co-catalyst to help in the pinacol rearrangement step.¹⁴

Further studies have shown this methodology can be applied to various substrates using different acyloins. These modifications have been performed to examine the stereoselectivities involved in both the aldol reaction and pinacol rearrangement, as well as the functionalizability of the geminal acylation products, so as to better understand the scope and limitations of this methodology going forward in natural product synthesis.

2.2 The Scope and Limitations of the Geminal Acylation

2.2.1 Modification of the Acyloin

The initial Mukaiyama-aldol addition is not only viable with the succinoin **2**, but with other acyloins as well. These can be prepared according to Bloomfield by the condensation of diesters in refluxing toluene with finely dispersed sodium metal, then trapping the dianion with chlorotrimethylsilane.^{15,16} Wu and Burnell have shown that a five-membered ring acyloin (**8**), a homolog of **2**, will yield 2,2-disubstituted-1,3-cyclohexanediones following the one-pot procedure with excess $\text{BF}_3 \cdot \text{OEt}_2$ (Scheme 4A).¹⁷ Relief of ring strain cannot be a necessary condition for the pinacol rearrangement step to occur because high yields (75%-95%) were obtained for unhindered ketals. In an earlier publication, Pattenden and Teague had reported that pinacol intermediate **9** underwent an alternative rearrangement (Scheme 4B) when pTSA was used to form the desired diketone.¹⁸

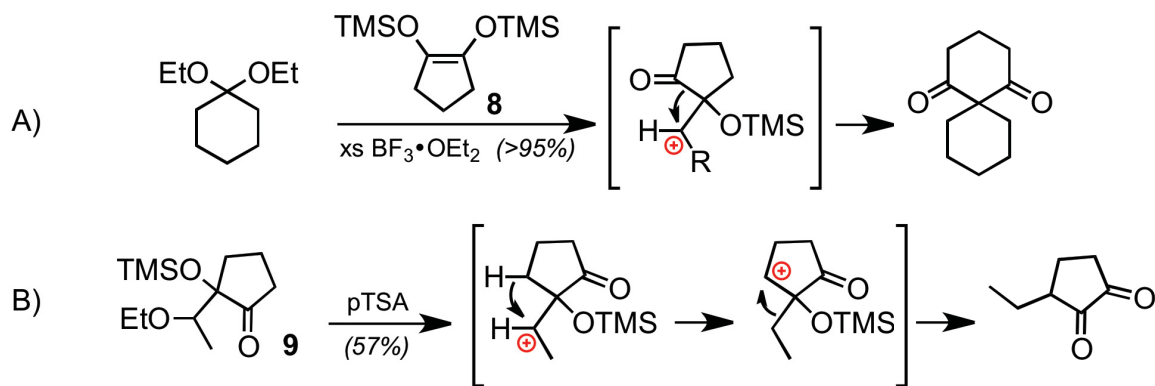

Scheme 4. A) Geminal acylation with a five-membered acyloin. B) The formation of a 1,2-diketone.

Modifications were also done on four-membered acyloins to examine the effects of substitution with alkyl groups.¹⁹⁻²¹ The reactions of **10**, a monomethylated analog of **2**, had similar yields to the reactions of **2**. Modest diastereoselectivity was observed with substituted ketone substrates, such as 4-*tert*-butylcyclohexanone, and its ketal. It was interesting to note that the ketone and ketal had complementary preferences for the two diastereomers produced. Whereas the ketone generated **11a** predominantly (3.1:1) over **11b**, and the dibenzyl ketal provided **11b** predominantly (7.5:1) over **11a** (Scheme 5). Because the isomeric ratios of the pinacol intermediates were similar to the ratios of the cyclopentanedione products, it is likely that the stereoselectivity was introduced during the aldol step. The reason why ketones gave largely the opposite diastereomer was thought to be due to an equilibration of the pinacol in the protic medium.¹⁹ A geminal dimethyl-substituted acyloin **12** was also prepared and reacted with benzylic ketones and ketals (along with acyloins **2** and **10**), providing cyclohexanedione products, but also producing some furanone **13** and 1,2-diketone byproducts **14** (Scheme 6).²⁰

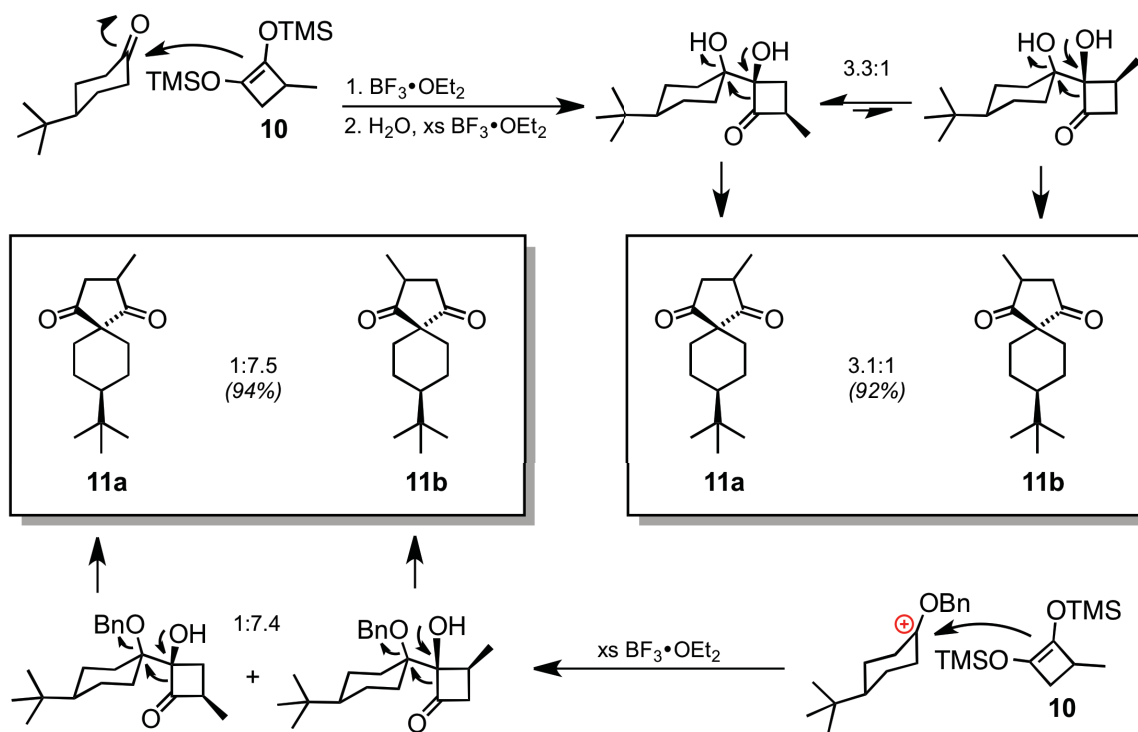

Scheme 5. The stereoselectivity of 10.

The dimethyl-substituted acyloin **12** gave lower yields than the less substituted acyloins, which was not surprising given the steric implications, but the diastereoselectivity was often higher for **12** than with **10**.¹⁹⁻²¹ Along with modest yields, geminal acylation reactions using **12** were plagued with unwanted byproducts (Scheme 6A). To circumvent this problem, Crane and Burnell used BCl_3 in lieu of $\text{BF}_3 \cdot \text{OEt}_2$ to initiate the reaction.²¹ The result of this was a boron complex, which prevented equilibration from occurring and prevented the formation of furanones and 1,2-diketones. This boron complex was then hydrolyzed with HF, and TFA was used to initiate the pinacol rearrangement. This was all in a three-step, but one-pot, reaction (Scheme 6B). Reactions were also attempted with a tetramethyl acyloin, but furanone products were obtained exclusively.¹⁹

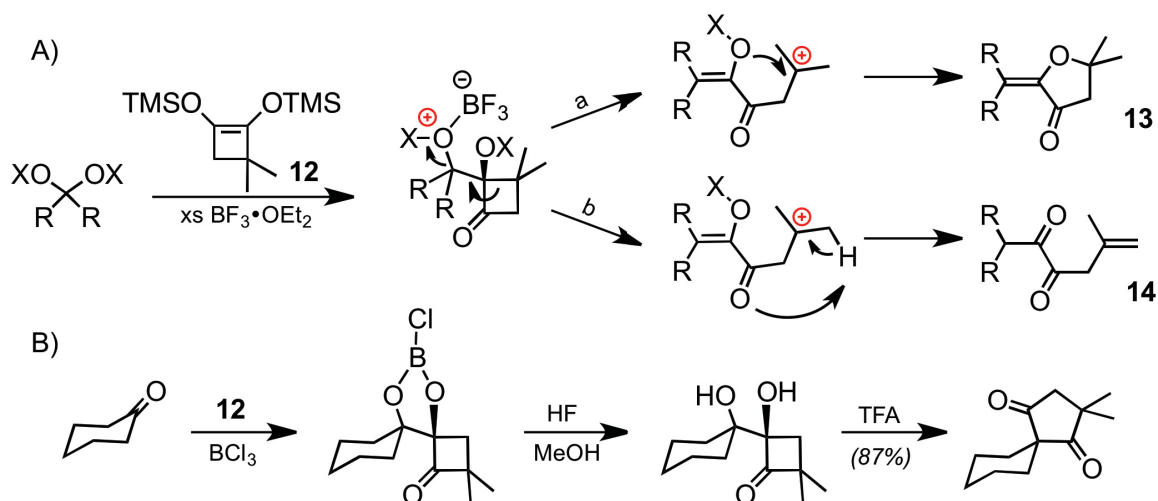

Scheme 6. A) Byproducts of the geminal acylation reaction with 12. B) The improved geminal acylation reaction of ketones with 12.

Several aliphatic acetals were also subjected to a cyclohexyl-fused succinoin **15** (Figure 2). Yields were comparable to those of reactions with **2**, aside from the diethyl acetal of benzaldehyde, which gave a 20% increase in the yield of the 1,3-diketone.²² The yields of 1,3-diketones from **15** and from **2** are compared in Table 1.

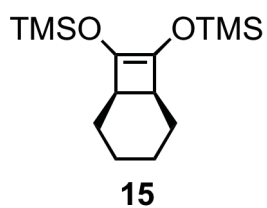
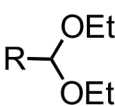
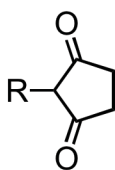
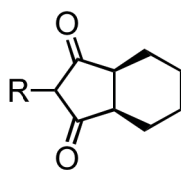

Figure 2. Acylin 15.

Table 1. The geminal acylation of acetals with 2 and 15.

| Entry |  |  |  |
|-------|---|---|---|
| | R = | %Yield | % Yield |
| 1 | Methyl | 79 | 84 |
| 2 | Nonyl | 87 | 86 |
| 3 | Prenyl | 86 | 83 |
| 4 | Cyclohexyl | 83 | 86 |
| 5 | Phenyl | 64 | 84 |
| 6 | Cinnamyl | 51 | 49 |

2.2.2 Modification of the Substrate

This simple method of generating 1,3-diketones from carbonyl-containing molecules (or acetal/ketal derivatives) works well in general, providing high yields with the ability to control chemo- and stereoselectivity; however, there are some drawbacks to this process. Simple enones, such as 2-cyclohexen-1-one give very poor yields, unless there was substitution on the β -carbon (Entries 1 and 2, Table 2).¹³ α -Alkyl substituents on a ketone also lower the yield by about 30% due to steric hindrance, although α -heterosubstituted cyclohexanones can provide useful yields of products when the pinacol step was mediated by an acidic Amberlyst-15 resin (Entry 5, Table 2).^{13,23}

Table 2. Geminal acylation of substituted ketones.

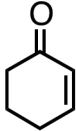
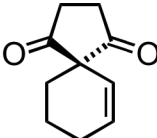
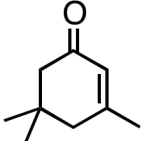
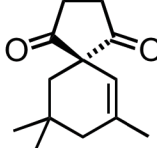
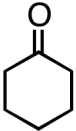
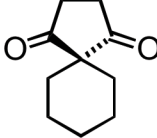
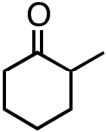
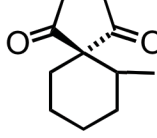
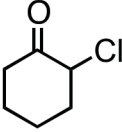
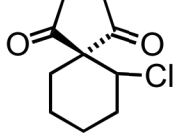
| Entry | Ketone | Product | % Yield |
|-------|---|--|-----------------|
| 1 |  |  | 2 |
| 2 |  |  | 33 |
| 3 |  |  | 94 |
| 4 |  |  | 62 |
| 5 |  |  | 73 ^a |

^a Pinacol rearrangement was achieved using Amberlyst-15.

Bach and Klix²⁴⁻²⁶ showed that dithioketals undergo the same Mukaiyama-aldol reaction as ketones and ketals, when the pinacol rearrangement step was initiated by an almost neutral mercuric chloride salt instead of under acidic conditions. Orthoesters can undergo geminal acylation, but the yields are low due to acid-catalyzed ring opening of the 1,3-diketone products to form γ -ketodiester.²⁷ The cyclobutanone intermediates, however, can be isolated in moderate to high yield.²⁸ Primary and secondary amides do not afford 1,3-diketones because the acyloin reacts with the nitrogen, rather than with the carbonyl, forming

aminocyclobutanones.²⁹ This method of making *N*-substituted cyclobutanones is still useful as it has been used to make natural products and potential drug molecules.³⁰⁻³²

Geminal acylation can be carried out with 2-methoxyoxazolidines (**16**) to form 1,4-oxazines (**18a,b**).³³ The initial aldol reaction displaces the methoxy group to form a cyclobutanone intermediate. Depending on the presence or absence of water, the ring expansion step either takes place by cleavage of the C-N bond, or the C-O bond, respectively (Scheme 7) to give **17a** or **17b**. These compounds can further cyclize to form cyclopenta[*b*][1,4]oxazinones (**18a,b**).

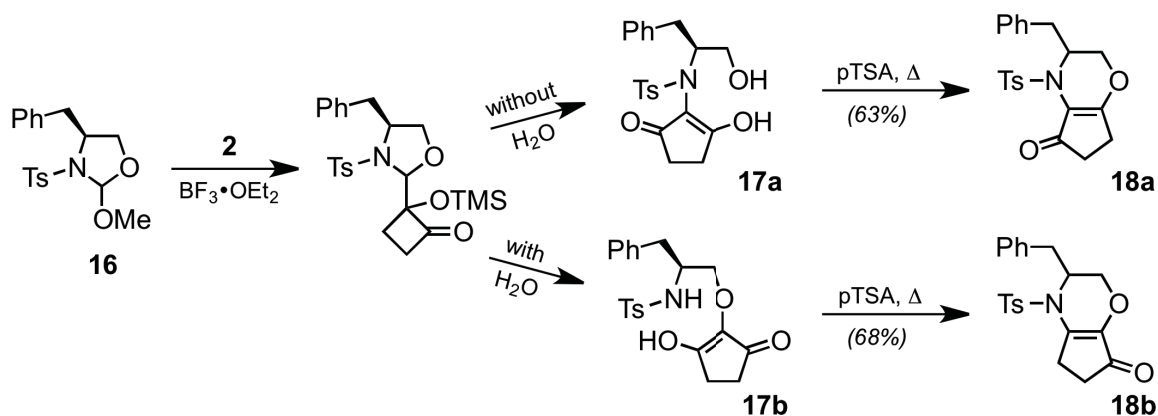

Scheme 7. The geminal acylation of a 2-methoxyoxazolidine.

2.2.3 Post Geminal Acylation Modifications

Aside from forming 1,3-diketones and γ -ketoesters, the products of geminal acylation contain functional groups that can be further derivatized into molecules of synthetic interest. Anderson and Lee used this method to derivatize a 1,3-diketone **19** made from the ketal of a mesylated 2'-hydroxy-5'-methoxyacetophenone. They

transformed **19** into a benzo[*b*]furan derivative **20** by opening the cyclic ketone using sodium hydroxide and methanol. After a few more operations, this intermediate has become a trichothecane analog **21**, a class of fungal metabolites that possess biological activity (Scheme 8).^{34,35}

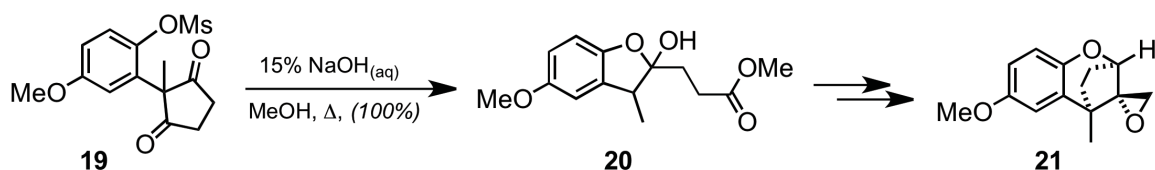

Scheme 8. The synthesis of a trichothecane analog.

Further cyclizations onto the 1,3-cyclopentanedione can be achieved if the substrate contains an alkyne. The treatment of ketal **22** with the acyloin **2** following the improved methodology (15 equiv. of $\text{BF}_3 \cdot \text{OEt}_2$) provided the geminal acylation product **23**, which was converted to the ring expanded product **24** when left in the acidic solution for 48 h (Scheme 9).³⁶ Follow-up studies have shown that reacting molecules like **23** with different Lewis acids, in the presence or absence of water, formed many structural isomers of **24**.^{37,38} A geminal acylation product containing an ester functionality **26** can undergo intramolecular coupling with the cyclic diketone in the presence of low-valent titanium to form a [3.3.0]bicyclic product **27** in modest yield, but in very few steps (Scheme 9).³⁹

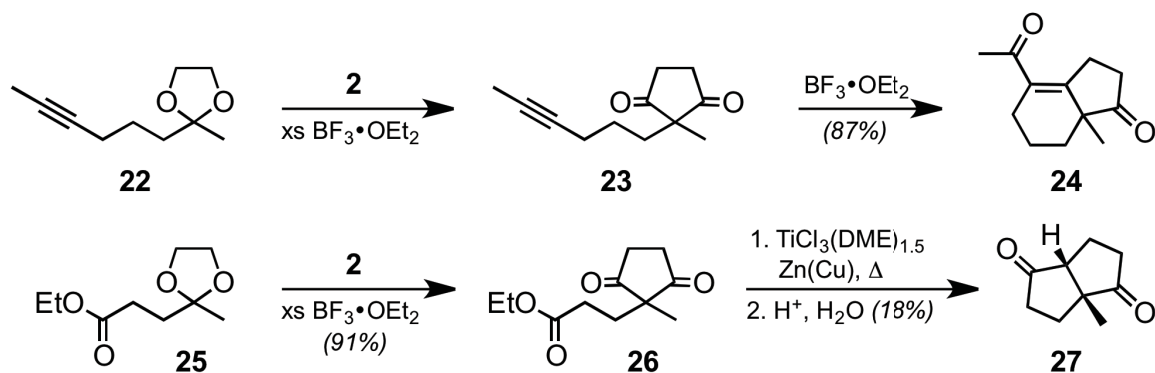

Scheme 9. Further manipulation of geminal acylation products 23 and 26.

These post-geminal acylation modifications are especially useful when planning a synthetic route. It is easy to imagine synthetic targets that contain 1,3-cyclopentanedione moieties as prime candidates for geminal acylation, but the functionalizability of these compounds has shown many different ring systems can be achieved after geminal acylation. For example, as was previously mentioned, the derivatization of diketone **19** to form benzo[*b*]furans proved key in the synthesis of trichothecane analogs.

2.3 Natural Product Synthesis Using Geminal Acylation

The trichothecanes belong to the sesquiterpene family of natural products, of which many have been synthesized using a geminal acylation as a key step. Most notably, they include β -bulnesene (**28**),⁴⁰ (\pm)-isokhusimone (**29**),^{12,41} (\pm)-pentalenene (**30**),⁴² and (\pm)- β -herbertenol (**31**)⁴³ (Figure 3).

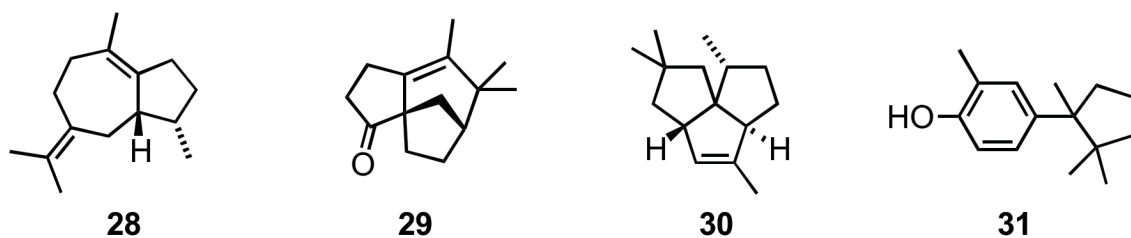
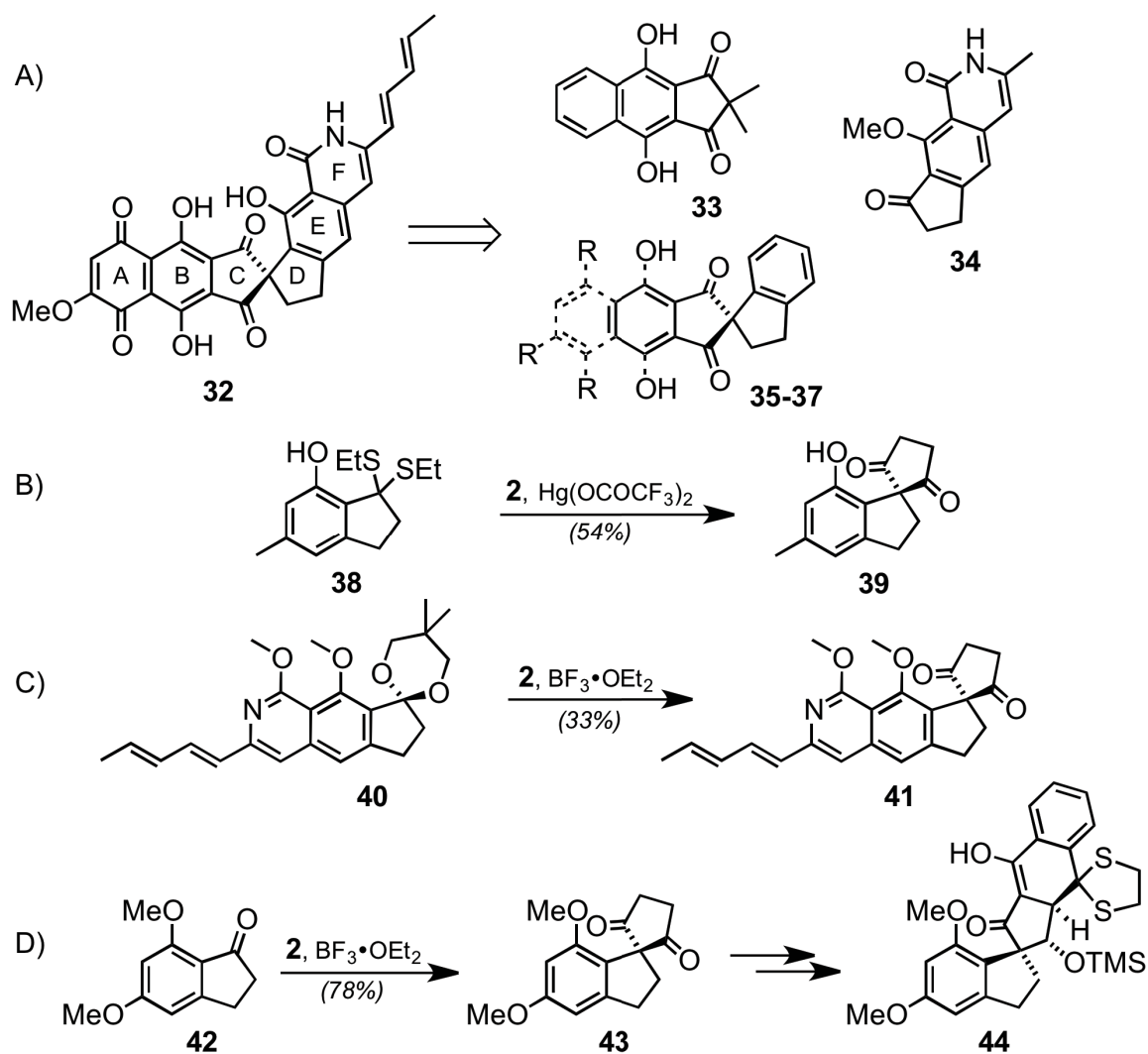

Figure 3. Sesquiterpenes made by geminal acylation.

Considerable effort by many research groups has been directed toward the synthesis of (\pm)-fredericamycin A **32**, a spirodiketone polycyclic molecule with potent antitumour properties.⁴⁴ Since geminal acylation has been shown to produce spirodiketones in very few steps, the process has been used to construct the C and D rings of the natural product. Parker *et al.* were the first to use this geminal acylation methodology to make synthons for **32** (Scheme 10 A). They first established the A-B-C ring system by preparing **33**, beginning with a geminal acylation of the methyl ketal of acetone followed by the addition of the A-B ring system in two more steps.⁴⁵ They later published a method to prepare the D-E-F ring system by producing **34** with the idea of carrying out a geminal acylation on the ketone (or ketal derivatives) of the D ring.⁴⁶ Bach and coworkers were also exploring various synthons during the same time period, looking to make the core structure of **32**. They first synthesized the B-C-D-E ring system **35** via geminal acylation onto a thioketal,²⁵ then added the A ring (unsubstituted) **36** to the same molecular framework.²⁴ They later managed to substitute the A ring with three methoxy groups and the B ring with two phenolic groups to form **37**.²⁶ They would finally complete the total synthesis of (\pm)-**32** in 1994 using the same thioketal approach (Scheme 10 B).⁴⁷ The total synthesis of (\pm)-**32** was also completed the year before

by Saint-Jalmes *et al.*, who also used a geminal acylation step, employing it on an already functionalized ketal **40** further on during the synthesis, forming spirocycle **41** (Scheme 10 B).⁴⁸ In 2009, Morrison *et al.* reported an improved synthetic route to core synthons of **32**. The geminally acylated product **43** was transformed into the A-B-C-D-E core containing molecule **44** in an overall yield of 31% (Scheme 10 D).⁴⁹



Scheme 10. A) Synthons prepared for the synthesis of **32**. B) Wendt's geminal acylation step. C) Parker's geminal acylation key step. D) Morrison's geminal acylation key step and core synthon.

The fungitoxic metabolite (–)-chokol G **45** has also been synthesized using geminal acylation as a key step.⁵⁰ The synthesis began with the formation of the acyloin **46** and its reaction with 1,1-dimethoxyethane, followed by treatment with dimethylsulfate and sodium hydride to form the methyl enol ether of a geminally acylated product **47** (Scheme 11). Following a reduction and an asymmetric hydrogen transfer, intermediate (–)-**48** was produced in high enantiomeric excess (87-98% ee). Compound **49** was then converted to a cuprate to form the *exo* product **50** from its reaction with **48**. The α -methyl of ketone **50** was epimerized to the thermodynamically favoured *trans* product after refluxing in diphenyl ether, which also produced a cyclopentenone product from the elimination of cyclopentadiene by a retro-Diels-Alder reaction. After three more minor operations, the total synthesis of the natural product (–)-**45** was accomplished. The stereoselectivity in this synthesis was largely controlled by the acyloin and the geminal acylation adduct it formed.

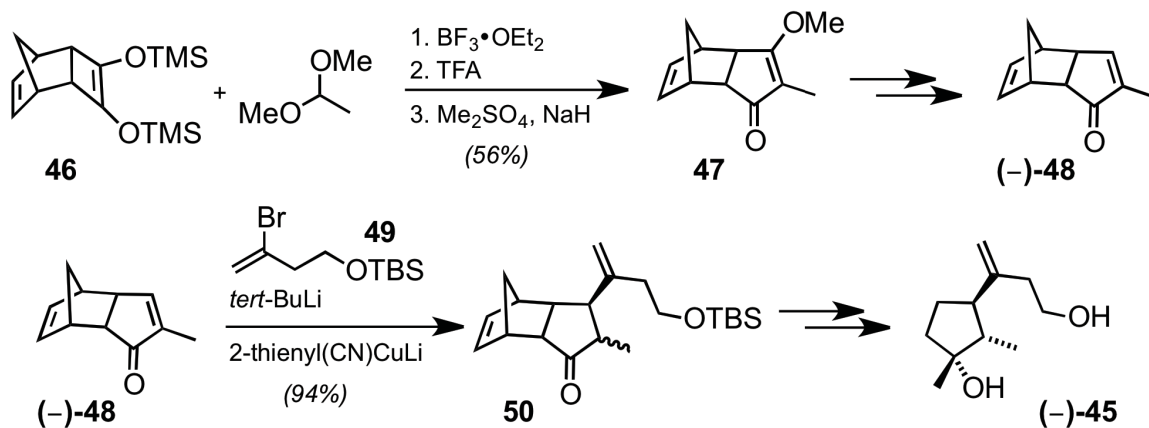

Scheme 11. The total synthesis of (-)-chokol G 45.

Other natural products, and analogs thereof, were synthesized with geminal acylation as a key step. These include aquariolide diterpenes,^{51,52} indolizidine analogs,⁵³ a cephalotaxus alkaloid,⁵⁴ and a steroidal diene.⁵⁵ These natural products are structurally very different, but all of them were accessible through geminal acylation.

2.4 My Research Project

2.4.1 Synthesis of a Propellane Using Geminal Acylation

This geminal acylation methodology has been shown to be useful for making otherwise synthetically difficult molecules, which include cyclobutanones and spirocycles. It was hypothesized that a propellane might also be prepared using this methodology in three successive steps, although it was recognized that this was a high-risk endeavour and we anticipated some difficulties. The term “propellane” is used to describe a tricyclic system conjoined by a single carbon-carbon bond. It

is not a coincidence that these molecules are similar in appearance to a propeller. A number of natural products contain a propellane skeleton, including modhephene **51** (Figure 4), a [3.3.3]-propellane that was first isolated in 1978 from *Isocoma wrightii*.⁵⁶

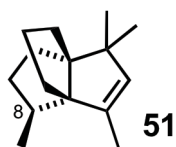
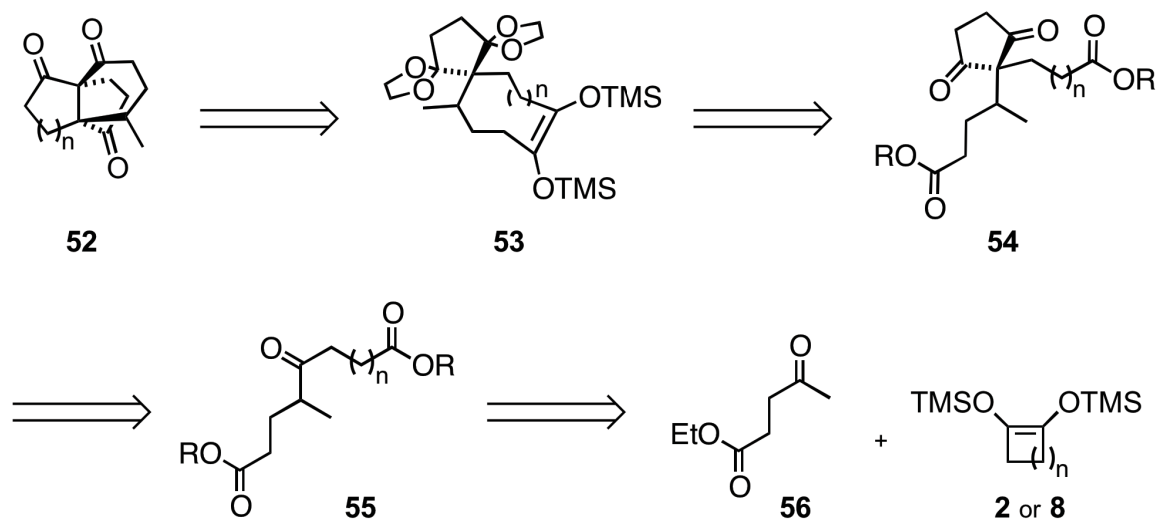

Figure 4. Modhephene.

Modhephene has been synthesized 18 times, via anionic cyclizations, by radical reactions, and by acid-catalyzed, thermal, and photochemical rearrangements.⁴ The greatest difficulty encountered in these syntheses has been the stereoselective installation of the C-8 methyl group. Incorporating this methyl group into the geminal acylation methodology was anticipated to present a challenge because a geminal acylation would have to occur onto a site with an α -substituent. Nevertheless, there was some precedent that this was achievable (Table 2, Entry 4).^{13,23} Other anticipated difficulties included the formation of an acyloin in the presence of other oxygen functions (where the acyloin would be made in a highly reducing medium), and a transannular geminal acylation (which would take place on the congested ketal). Transannular geminal acylation was unprecedented, but an intramolecular geminal acylation had been achieved.⁵⁷

2.4.2 Retrosynthesis

Transannular ring closure had been achieved by other methods to form propellane carbon frameworks by Reingold⁵⁸ and by Yamago.^{59,60} It was proposed that a [4.n.3]-propellane **52** might be synthesized by the intramolecular spiroannulation of **53** (Scheme 12). The tetracyclic structure of **53** could be made from the acyloin condensation of **54**. Not surprisingly, the 1,3-diketone of **54** would arise from the geminal acylation of ketone **55** or its ketal. The ketodiester **55** could itself come from another geminal acylation of ethyl levulinate **56** followed by ring opening reductive succinylation of the 1,3-diketone formed. Using either succinoin **2** or the five-membered acyloin **8**, we considered that the length of the carbon chain might be varied to ultimately form [4.3.3]- or [4.4.3]propellanes.



Scheme 12. Retrosynthesis of a [4.n.3]-propellane.

If successful, this functionalizable analog of **51** would be synthesized in eight steps or less via three consecutive geminal acylation reactions, beginning with a readily available starting material.

2.5 Results and Discussion

Both four- and five-membered acyloins **2** and **8** were synthesized based on a literature procedure¹⁶ (Scheme 13), using diethyl succinate to make **2** and dimethyl glutarate to make **8**. Yields were also noticeably better when fresh chlorotrimethylsilane from an unopened bottle was used.

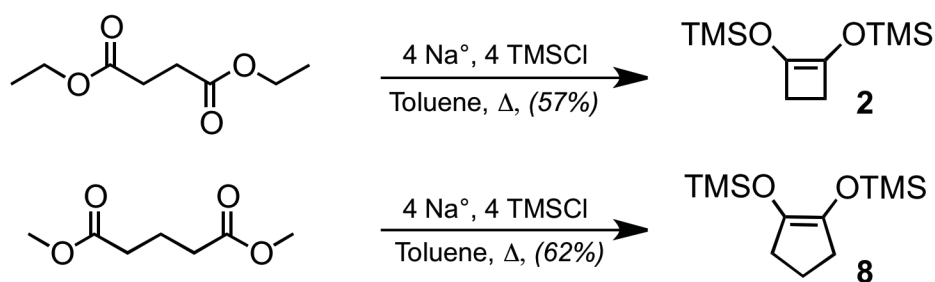

Scheme 13. Acyloin condensation using TMSCl as the trapping agent.

These acyloins were surprisingly stable as long as they were kept away from moisture. Both reagents were stored at rt under a N₂ atmosphere, and they did not decompose to any noticeable extent over many months.

As discussed earlier in this chapter, there are different procedures to pick from when it comes to geminal acylation. Because using ketals often leads to higher yields than from ketones, and since the one-pot procedure was previously developed in this lab, it was the methodology employed throughout this project.

The first step toward modhephene was to make a ketodiester such as **55** from the ketal of ethyl levulinate **56**. Kuwajima reported that ketodiesters could be formed from ketals using SnCl₄ as a Lewis acid.^{61,62} The ethylene glycol ketal of ethyl levulinate **57** was prepared following a standard procedure.⁶³ Unfortunately, Kuwajima's method did not produce any of the expected ketodiester **58**, and the starting ketone was recovered in 70% yield (Scheme 14). The same reaction was attempted using **8**, but, once again, the only material recovered was the starting ketone **56**.

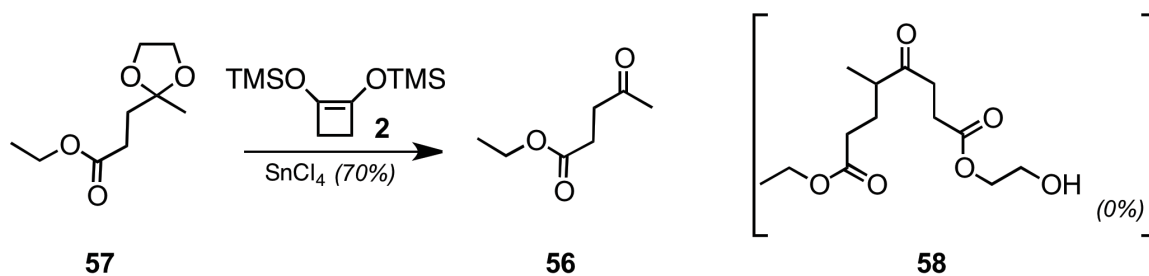

Scheme 14. Attempted synthesis of a ketodiester.

When **57** and **2** were reacted with excess BF₃•OEt₂, the 1,3-diketone was formed in yields near 80%, accompanied by traces of ketodiester. It was speculated that the ketodiesters were formed from an acid-catalyzed ring opening reaction involving ethylene glycol, once it has been cleaved from the ketal.⁶⁴ With this in mind, excess ethylene glycol was added to the reaction mixture of **57** and **2** after TLC analysis showed the ketal was completely consumed. The result was a mixture of 30% ketodiester **58** and 15% 1,3-diketone **59** (Scheme 15).

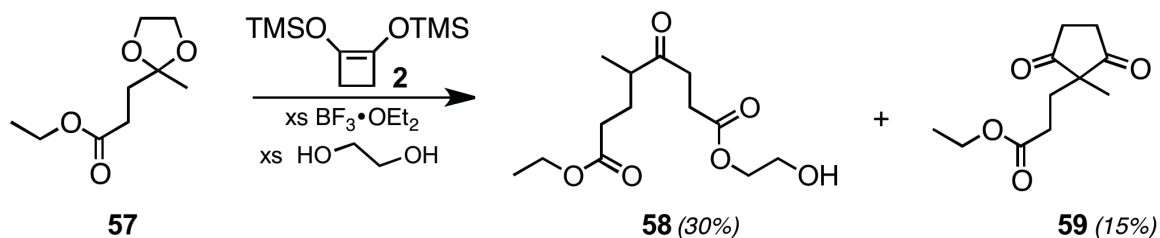

Scheme 15. Acid-catalyzed ring-opening of a 1,3-diketone.

However when **58** was converted to its ethylene glycol ketal, it did not undergo a second geminal acylation. It was thought this reaction might be inhibited due to the ethylene glycol ester, as previous studies have shown that ketals containing a hydroxyl substituent did not yield any geminal acylation product.²⁷ Thus a *tert*-butyldimethylsilyl (TBS) group was used to protect the alcohol.⁶⁴ Unfortunately, this TBS-protected derivative did not produce any 1,3-diketone, either.

When **57** was reacted with **8** in the presence of $\text{BF}_3\cdot\text{OEt}_2$, the reaction mixture mostly contained the ring-opened product, which was then transesterified with methanol to avoid the problems observed with the ethylene glycol ester. This polar intermediate was then converted to the ethylene glycol ketal **61** in 80% yield. Unfortunately, the standard one-pot geminal acylation procedure with **2** gave none of the desired 1,3-diketone **62**; instead, only **60** was recovered (Scheme 16).

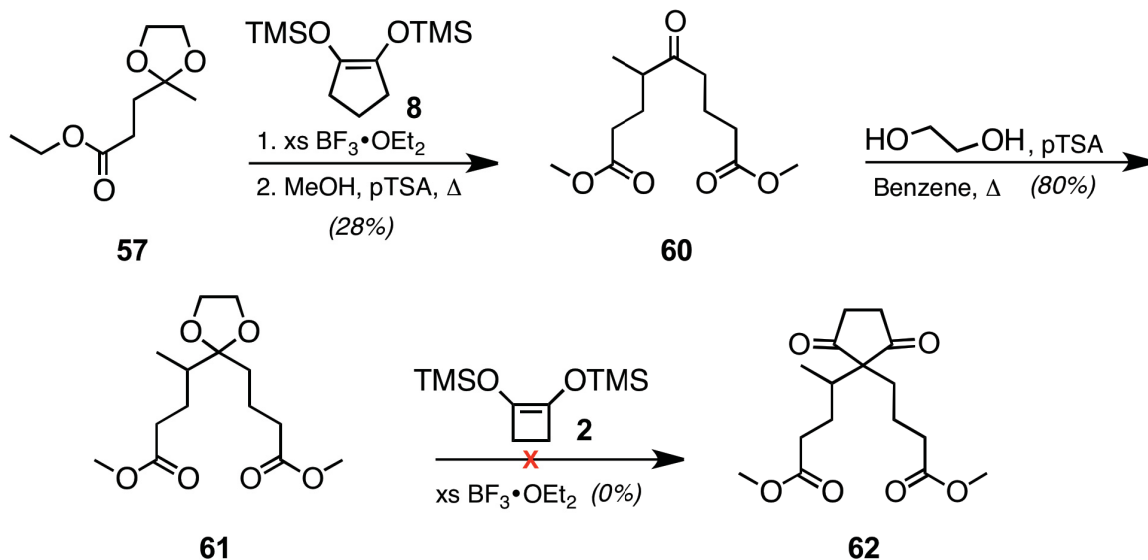

Scheme 16. Initial attempts at the geminal acylation of 61.

Kawata *et al.* had reported that a 1,3-cyclohexanedione could undergo a ring-opening reaction with an alcohol in the presence of indium(III) trifluoromethanesulfonate in catalytic amount.⁶⁵ Unfortunately, when the same conditions were employed with the 1,3-diketone **59**, only the transesterified product was produced in 73% yield. Conversely, the ketodiester could be generated by the base-induced ring-opening of **59**, followed by esterification of the resulting carboxylic acid to produce a dimethylated ketodiester. This method gave **63** in 35% yield, but although the yield was low, it was still a much more attractive method than those previously mentioned (Scheme 17). Its ethylene glycol ketal **64** was then subjected to geminal acylation conditions with **2**, but the diketone product **65** was not observed.

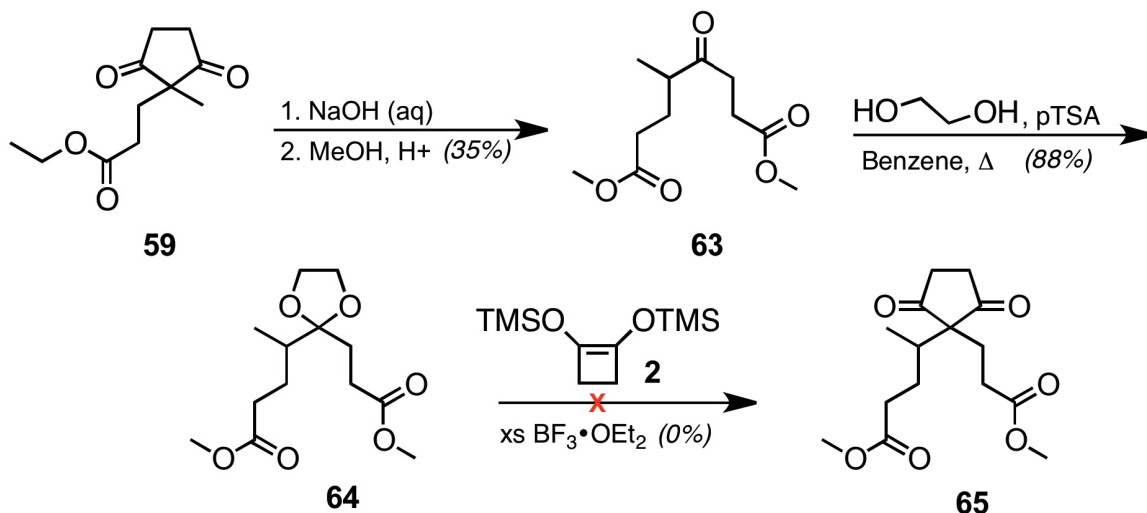

Scheme 17. A new method for the generation of a ketodiester then its protection.

Because these products were very polar and difficult to purify by column chromatography on silica gel, *n*-hexanol was used for the transesterification of **58** to add hydrophobicity. A 43% yield was obtained when using pTSA, but indium(III) trifluoromethanesulfonate yielded 60% of the dihexyl ketodiester **66**. Geminal acylation was attempted following the transformation of **66** to its ethylene glycol ketal **67**, but, once again, only **66** was recovered this time in 33% yield. (Scheme 18).

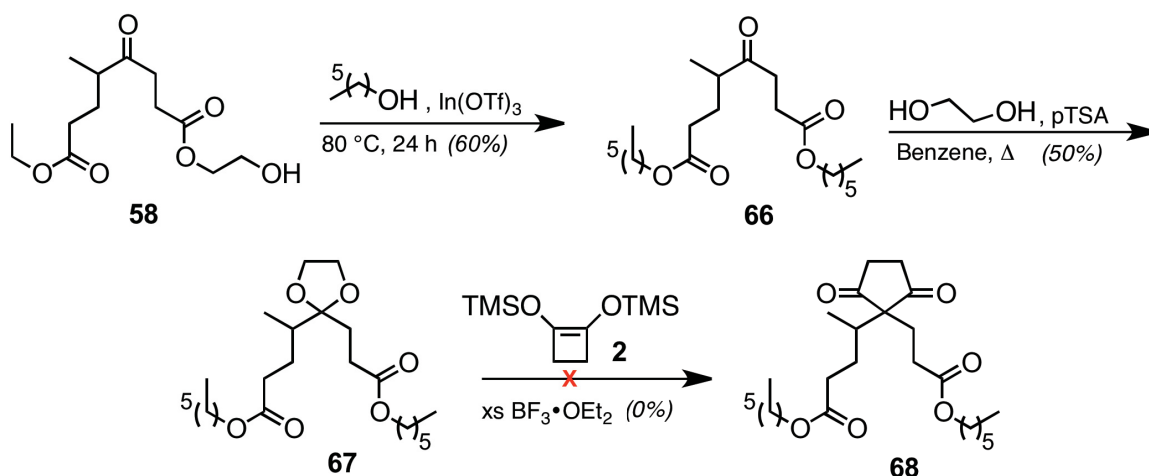

Scheme 18. Attempted geminal acylation of a transesterified ketodiester.

Many attempts were made at converting **63** and its ethylene glycol ketal **64** into a geminally acylated product. Despite testing several temperatures and trying TiCl_4 as the Lewis acid, no geminal acylation product was ever observed by NMR spectroscopy. The formation of the cyclobutanone intermediate had not been observed either, so it seemed that the α -methyl substituent was simply too sterically encumbering for the initial Mukaiyama aldol-type step to occur.

The next approach to propellane synthesis involved the use of ketodiester without the methyl substituent. It was unfortunate that the methyl could not be carried through, as it is the stereoselective installation of this methyl group that has made modhephene tricky to synthesize. It also existed as an element of non-symmetry, which could have imparted diastereoselectivity during the transannular geminal acylation step. Regardless, synthesizing a propellane via geminal acylation would still be the first of its kind, with or without a methyl group.

Thus, a methyl-free analog of **59** was made, beginning with the Michael addition of 1,3-cyclohexanedione and ethyl acrylate, generating **69**, which existed largely as the enol **70**. This was then followed by an acid-catalyzed ring opening of **70** to yield a diethyl ketodiester **71** (Scheme 19). After converting **71** to its ethylene glycol ketal **72**, a geminal acylation was attempted using **2**. This reaction was performed only once on small-scale, but the ^1H NMR spectrum of the crude reaction mixture did not show any signals for **73**, but did show reversion to **71**.

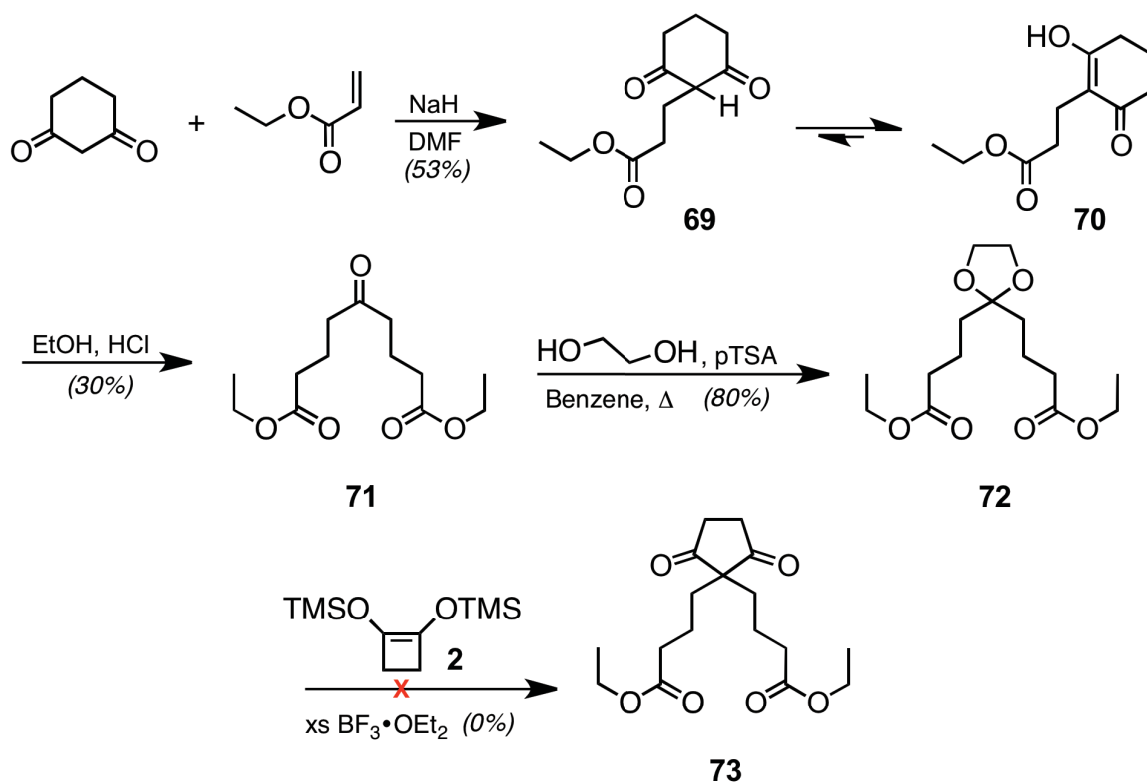

Scheme 19. Synthesis of the unmethylated ketodiester.

The project was suspended at this juncture.

2.6 Conclusions & Future Work

A series of ketodiester was synthesized with the goal of converting their ethylene glycol ketals into geminally acylated products. The presence of a methyl substituent α to the electrophilic center was hypothesized to be preventing the formation of cyclobutanone intermediates when no geminally acylated products were observed.

An unmethylated ketodiester was also prepared, but its initial reaction with **2** was also unsuccessful, therefore the presence of a diester moiety might be the reason why the reaction would not go to completion.. Further attempts need to be made at synthesizing the geminally acylated product **73**, possibly by employing the two-step procedure if the cyclobutanone intermediate can be isolated. Once **73** has been prepared, attempts will be made to transform its ketal **74** (with multiple variations to try) into acyloin **75** and to induce geminal acylation *in situ* to form propellane **76** (Scheme 20).

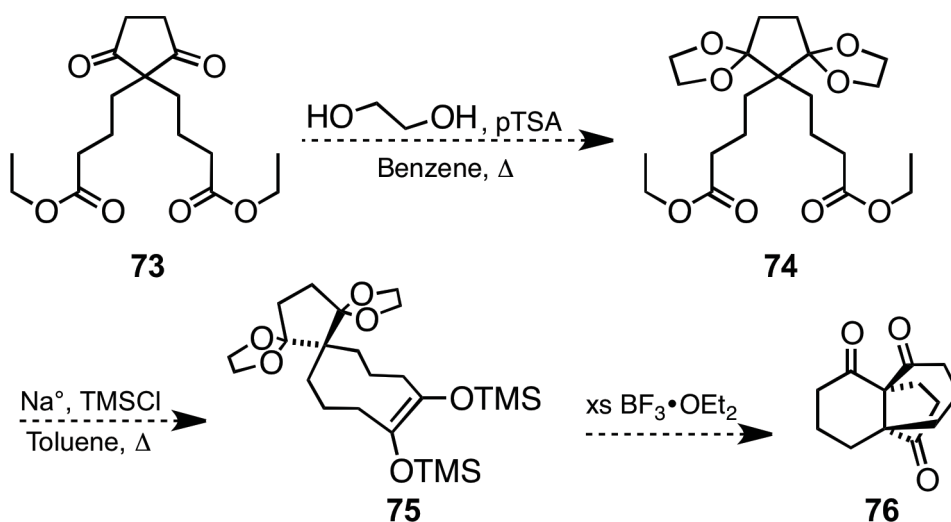

Scheme 20. Future attempt toward the synthesis of 76.

If successful, this would constitute the first transannular geminal acylation reaction, as well as the first propellane synthesized with geminal acylations as key steps.

2.7 Experimental

2.7.1 General Considerations

All non-aqueous reactions were conducted in oven-dried glassware under an N_2 atmosphere. Reagents were obtained from Sigma-Aldrich or Alfa/Aesar and were used as received. Dichloromethane and toluene were freshly distilled from calcium hydride. Ethyl acetate and hexanes for column chromatography were distilled. All other solvents were used without further purification.

TLC was conducted using pre-coated aluminum-backed silica plates (SiliCycle, silica gel 60 F₂₅₄), using UV light (254 nm) as a visualizing agent and *o*-vanillin in ethanol/H₂SO₄ and heat as developing agents. Flash chromatography was carried out on silica gel purchased from SiliCycle (40-63 μm particle size, 230-240 mesh).

Melting points (uncorrected) were acquired using a Fisher-Johns apparatus. ¹H NMR spectra were recorded at 500 MHz on a Bruker Avance spectrometer with CDCl₃ as solvent (δ 7.26 ppm) with tetramethylsilane as the internal reference (δ 0.00 ppm). ¹³C NMR spectra were recorded at 126 MHz on the Bruker Avance spectrometer with CDCl₃ as solvent and as internal reference (δ 77.16 ppm). High-resolution mass spectra were acquired by Mr. Xiao Feng on a Bruker microTOF Focus orthogonal ESI-TOF mass spectrometer.

All structures were determined using ¹H and ¹³C NMR spectra, along with two-dimensional NMR experiments (COSY, HSQC and HMBC).

2.7.2 Preparation and Characterization Data

1,2-Bis(trimethylsilyloxy)cyclobutene (**2**)

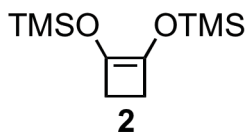

A solution of diethyl succinate (16.6 mL, 100 mmol) and chlorotrimethylsilane (50.8 mL, 400 mmol) in toluene (125 mL) was added

dropwise over a period of 4 h to a refluxing dispersion of molten sodium (420 mmol, 9.71 g) in toluene (250 mL). A dark purple precipitate appeared within 20 min of addition, but then it quickly turned dark brown. The mixture was heated under reflux overnight, then cooled to rt and filtered through a sintered-glass funnel. The filtrate was concentrated *in vacuo* and distilled under reduced pressure (bp 53-54 °C / 5 mmHg) to yield **2** (13.1 g, 57%) as a colorless liquid: ¹H NMR (500 MHz, CDCl₃): δ 2.14 (s, 4H), 0.20 (s, 18 H); ¹³C NMR (126 MHz, CDCl₃): δ 120.2, 26.2, 0.5. These data match those in the literature.^{66,67}

1,2-Bis(trimethylsilyloxy)cyclopentene (**8**)

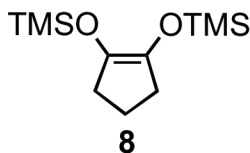

A solution of dimethyl glutarate (14.8 mL, 100 mmol) and chlorotrimethylsilane (50.8 mL, 400 mmol) in toluene (125 mL) was added dropwise over a period of 4 h to a refluxing dispersion of molten sodium (420 mmol, 9.71 g) in toluene (250 mL). The solution turned green within 15 min of addition, then gradually became yellow over 2 to 3 h, and eventually turned a dark brown. The mixture was heated under reflux overnight, then cooled to rt and filtered through a sintered-glass funnel. The filtrate was then concentrated *in vacuo* and distilled under reduced pressure (bp 90-92 °C / 4 mmHg) to yield **8** (16.0 g, 62%) as a colorless liquid: ¹H NMR (500 MHz, CDCl₃): δ 2.23 (t, *J* = 7.3 Hz, 4H),

1.76 (quintet, $J = 7.4$ Hz, 2H), 0.18 (s, 18 H); ^{13}C NMR (126 MHz, CDCl_3): δ 130.7, 30.3, 17.1, 0.9. These data match those in the literature.^{66,68,69}

Ethyl 4-(1,3-dioxolan-2-yl)pentanoate (**57**)

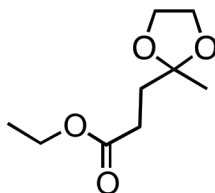

57

para-Toluenesulfonic acid (0.12 g, 6.0 mmol) was added to a solution of ethyl levulinate (28.4 mL, 200 mmol) and ethylene glycol (12.3 mL, 220 mmol) in benzene (100 mL). The solution was heated under reflux over 6 h with azeotropic removal of water using a Dean-Stark apparatus filled with 4 Å Molecular Sieves. The solution was cooled to rt, and the acid was quenched with triethylamine (2 mL). The organic solution was washed with water (2×100 mL) and brine (100 mL), dried over MgSO_4 , and concentrated *in vacuo*. The residue was purified by flash chromatography (25% ethyl acetate in hexanes) to provide **57** (33.7 g, 90%) as a colourless liquid: ^1H NMR (500 MHz, CDCl_3): δ 4.07 (q, $J = 7.1$ Hz, 2H), 3.88 (m, 4H), 2.32 (t, $J = 7.7$ Hz, 2H), 1.96 (t, $J = 7.7$ Hz, 2H), 1.26 (s, 3H), 1.19 (t, $J = 7.1$ Hz, 3H); ^{13}C NMR (126 MHz, CDCl_3): δ 173.6, 109.2, 64.8, 60.3, 34.0, 29.1, 24.0, 14.3. These data match those in the literature.⁷⁰

1-Ethyl 8-(2-hydroxyethyl) 4-methyl-5-oxooctanedioate (58) and ethyl 3-(1-methyl-2,5-dioxocyclopentyl)propanoate (59)

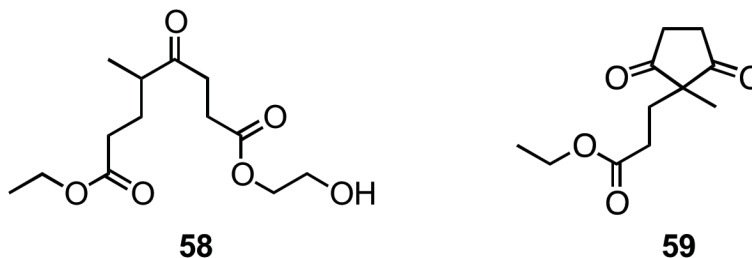

A stirred solution of ketal **57** (0.25 mL, 1.3 mmol) in CH₂Cl₂ (7 mL) was cooled to -78 °C. BF₃•OEt₂ (0.25 mL, 1.95 mmol) was added, followed by the dropwise addition of a solution of acyloin **2** (0.50 mL, 1.95 mmol) in CH₂Cl₂ (3 mL). The mixture was stirred at -78 °C for 3 h, then warmed to rt over 2.5 h. An excess of ethylene glycol (0.50 mL, 8.9 mmol) was added to the mixture, followed by BF₃•OEt₂ (2.4 mL, 19.5 mmol) then stirred overnight (~ 14 h). The solution was washed with water (2 × 10 mL), and the aqueous layer was re-extracted with CH₂Cl₂ (2 × 10 mL). The combined organic solutions was washed with brine (25 mL), dried over MgSO₄ and concentrated *in vacuo*. The residue was purified by flash chromatography (50% ethyl acetate in hexanes) to provide **58** (0.14 g, 30%) and **59**^{*} (42 mg, 15%), both as colourless oils: For **58**: ¹H NMR (500 MHz, CDCl₃): δ 4.23-4.21 (m, 2H), 4.13 (q, *J* = 7.1 Hz, 2H), 3.82-3.80 (m, 2H), 2.88-2.67 (m, 3H), 2.67-2.61 (m, 3H), 2.32-2.28 (m, *J* = 3.9 Hz, 2H), 2.05-1.98 (m, 1H), 1.72-1.64 (m, 1H), 1.26 (t, *J* = 7.1 Hz, 3H), 1.13 (d, *J* = 7.0 Hz, 3H); ¹³C NMR (126 MHz, CDCl₃): δ 212.4, 173.3, 173.1, 66.3, 61.0, 60.5, 45.2, 35.8, 31.7, 27.9, 27.7, 16.4,

^{*} **59** was made in 83% yield following the one pot procedure.⁵

14.2; HRMS (ESI) calcd for $[\text{C}_{13}\text{H}_{22}\text{O}_6\text{Na}]^+$: 297.1309, found: 297.1304. For **59**: ^1H NMR (500 MHz, CDCl_3): δ 4.10 (q, $J = 7.1$ Hz, 2H), 2.88-2.81 (m, 4H), 2.32 (t, $J = 7.5$ Hz, 2H), 2.00 (t, $J = 7.5$ Hz, 2H), 1.27 (t, $J = 7.1$ Hz, 3H), 1.17 (s, 3H); ^{13}C NMR (126 MHz, CDCl_3): δ 215.7, 172.8, 60.7, 55.3, 34.8, 28.8, 20.0, 14.1. These data match those in the literature.²⁷

Dimethyl 4-methyl-5-oxononanedioate (**60**)

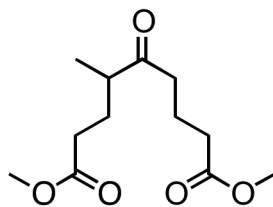

60

A stirred solution of ketal **57** (2.9 mL, 16 mmol) in CH_2Cl_2 (20 mL) was cooled to -78 °C. $\text{BF}_3 \cdot \text{OEt}_2$ (3.0 mL, 24 mmol) was added, followed by the dropwise addition of a solution of acyloin **8** (7.2 mL, 24 mmol) in CH_2Cl_2 (10 mL). The mixture was stirred at -78 °C for 3 h, then warmed to rt over 2 h. $\text{BF}_3 \cdot \text{OEt}_2$ (30.5 mL, 240 mmol) was added, then, the reaction mixture was stirred overnight (~ 14 h). The solution was washed with water (2×50 mL), and the aqueous layer was re-extracted with CH_2Cl_2 (2×50 mL). The solvent was then removed *in vacuo*. The resulting residue was dissolved in a solution of pTSA (0.15 g, 0.80 mmol) in methanol (50 mL), and the mixture was heated under reflux for 7 h. The solvent was then removed *in vacuo*, and the residue was diluted with ethyl acetate (50 mL)

and washed with saturated aqueous sodium bicarbonate (2×50 mL). The aqueous solution was re-extracted with ethyl acetate (50 mL), and the combined organic solutions was washed with brine (75 mL), dried over MgSO_4 and concentrated *in vacuo*. The residue was purified by flash chromatography (50% ethyl acetate in hexanes) to provide **60** (1.09 g, 28%) as a colourless oil: ^1H NMR (500 MHz, CDCl_3): δ 3.68 (s, 3H), 3.67 (s, 3H), 2.60-2.46 (m, 3H), 2.34 (t, $J = 7.2$ Hz, 2H), 2.31-2.24 (m, 2H), 2.02-1.95 (m, 1H), 1.89 (quintet, $J = 7.2$ Hz, 2H), 1.69-1.62 (m, 1H), 1.09 (d, $J = 7.0$ Hz, 3H). ^{13}C NMR (126 MHz, CDCl_3): δ 213.0, 173.8, 173.7, 51.75, 51.69, 45.3, 40.1, 33.1, 31.6, 27.7, 18.9, 16.5; HRMS (ESI) calcd for $[\text{C}_{12}\text{H}_{20}\text{O}_5\text{Na}]^+$: 267.1203, found: 267.1201.

Dimethyl 5-(1,3-dioxolan-2-yl)-4-methylnonanedioate (**61**)

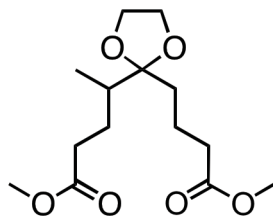

61

According to the procedure for **57**: ketodiester **60** (0.58 g, 2.0 mmol) was reacted with ethylene glycol (0.12 mL, 2.2 mmol) and *para*-toluenesulfonic acid (0.11 g, 0.6 mmol) in benzene (20 mL) to yield, after purification by flash chromatography (66% ethyl acetate in hexanes), **61** (0.53 g, 80%) as a colourless oil: ^1H NMR (500 MHz, CDCl_3): δ 3.96-3.91 (m, 4H), 3.67 (s, 3H), 3.66 (s, 3H),

2.44-2.38 (m, $J = 5.7$ Hz, 1H), 2.34-2.25 (m, 3H), 1.97-1.89 (m, 1H), 1.74-1.63 (m, 5H), 1.44-1.36 (m, 1H), 0.93 (d, $J = 6.9$ Hz, 3H); ^{13}C NMR (126 MHz, CDCl_3): δ 174.4, 174.1, 113.3, 65.4, 65.3, 51.7, 51.6, 39.2, 34.3, 33.1, 32.6, 26.7, 18.8, 14.2; HRMS (ESI) calcd for $[\text{C}_{14}\text{H}_{24}\text{O}_6\text{Na}]^+$: 311.1466, found: 311.1460.

Dimethyl 4-methyl-5-oxooctanedioate (**63**)

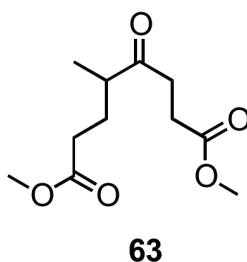

An aqueous solution of NaOH (1 M, 4.0 mL) was added to diketone **59** (0.42 g, 2.0 mmol) and the resulting emulsion was stirred at rt for 1 h. The mixture was washed with diethyl ether (5 mL), and the aqueous layer was acidified with HCl (1 M, 5 mL). The mixture was extracted with diethyl ether (2×10 mL), and the combined organic layers were dried over MgSO_4 , filtered, and concentrated *in vacuo*. The residue was dissolved in a solution of sulfuric acid (0.1 M, 0.8 mL) in methanol (8.0 mL, 0.20 mol). The mixture was heated under reflux for 4 h. Distilled water (10 mL) was added and stirring was continued for 10 min. The mixture was extracted with CH_2Cl_2 (30 mL), washed with saturated aqueous sodium bicarbonate (2×30 mL), and brine (30 mL). The organic layer was dried over MgSO_4 and concentrated *in vacuo*. The residue was purified by flash chromatography (50% ethyl acetate in hexanes) to afford **63** (0.16 g, 35%) as a

colourless oil: ^1H NMR (500 MHz, CDCl_3): δ 3.67 (s, 3H), 3.67 (s, 3H), 2.85-2.57 (m, 5H), 2.31 (td, $J = 7.5, 2.1$ Hz, 2H), 2.08-1.96 (m, 1H), 1.75-1.63 (m, 1H), 1.13 (d, $J = 7.0$ Hz, 3H). ^{13}C NMR (126 MHz, CDCl_3): δ 211.8, 173.7, 173.3, 51.9, 51.7, 45.4, 35.8, 31.6, 27.8, 16.5. These data match those in the literature.⁷¹

Dimethyl 4-(1,3-dioxolan-2-yl)-5-methyloctanedioate (**64**)

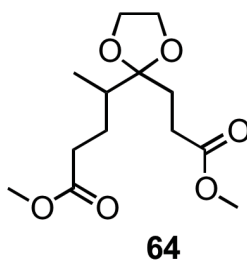

According to the procedure for **57**: ketodiester **63** (0.16 g, 0.69 mmol) was reacted with ethylene glycol (0.5 mL, 0.89 mmol) and *para*-toluenesulfonic acid (0.019 g, 0.10 mmol) in benzene (10 mL) to yield, after flash chromatography (66% ethyl acetate in hexanes), **68** (0.15 g, 80%) as a colourless oil: ^1H NMR (500 MHz, CDCl_3): δ 3.93-3.89 (m, 4H), 3.65 (br s, 6H), 2.87-2.66 (m, 2H), 2.65-2.53 (m, 2H), 2.24-2.22 (m, 2H), 2.06-2.04 (m, 1H), 1.73-1.71 (m, 1H), 0.91 (d, $J = 6.9$ Hz, 3H); ^{13}C NMR (126 MHz, CDCl_3): δ 174.0, 173.9, 113.0, 65.3, 65.1, 60.6, 60.4, 35.4, 34.2, 30.1, 27.4, 24.2, 15.6; HRMS (ESI) calcd for $[\text{C}_{13}\text{H}_{22}\text{O}_6\text{Na}]^+$: 297.1309, found: 297.1306.

Di-*n*-hexyl 4-methyl-5-oxooctanedioate (66)

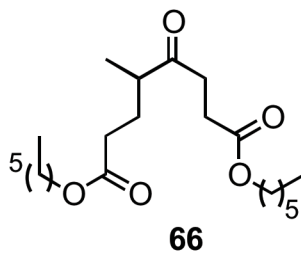

Indium(III) trifluoromethanesulfonate (45 mg, 0.080 mmol) was added to a solution of ketodiester **58** (0.11 g, 0.40 mmol) in 1-hexanol (6.0 mL). The solution was heated to 80 °C for 24 h. After being cooled to rt, the solution was diluted with ethyl acetate (20 mL) washed with H₂O (20 mL). The aqueous layer was re-extracted with ethyl acetate (20 mL), washed with brine (20 mL), dried over MgSO₄ and concentrated *in vacuo*. The residue was purified by flash chromatography (toluene) to yield **66** (89 mg, 60%) as a colourless oil: ¹H NMR (500 MHz, CDCl₃): δ 4.06 (t, *J* = 6.8 Hz, 4H), 2.84-2.78 (m, 1H), 2.75-2.69 (m, 1H), 2.66-2.61 (m, 1H), 2.60-2.57 (m, 2H), 2.32-2.27 (m, 2H), 2.04-2.00 (m, 1H), 1.70-1.66 (m, 1H), 1.64-1.58 (m, 4H), 1.37-1.26 (m, 12H), 1.13 (d, *J* = 7.0 Hz, 3H), 0.90-0.88 (m, 6H); ¹³C NMR (126 MHz, CDCl₃): δ 212.0, 173.4, 173.0, 65.0, 64.8, 45.4, 35.8, 31.9, 31.5 (2C), 28.7, 28.6, 28.0, 27.8, 25.7, 25.6, 22.6 (2C), 16.5, 14.1 (2C); HRMS (ESI) calcd for [C₂₁H₃₈O₅Na]⁺: 393.2611, found: 393.2608.

Di-*n*-hexyl 4-(1,3-dioxolan-2-yl)-5-methyloctanedioate (67)

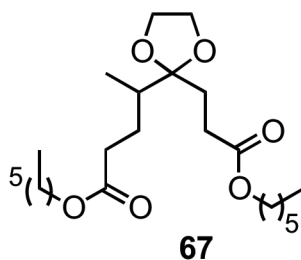

According to the procedure for **57**: ketodiester **66** (89 mg, 0.25 mmol) was reacted with ethylene glycol (0.02 mL, 0.30 mmol) and *para*-toluenesulfonic acid (14 mg, 0.070 mmol) in benzene (5 mL) to yield, after flash chromatography (toluene), **67** (52 mg, 50%) as a pale yellow oil: ^1H NMR (500 MHz, CDCl_3): δ 4.06-4.04 (m, 4H), 3.93-3.90 (m, 4H), 2.85-2.79 (m, 1H), 2.76-2.70 (m, 1H), 2.68-2.62 (m, 1H), 2.59-2.56 (m, 2H), 2.33-2.28 (m, 2H), 2.02-1.97 (m, 1H), 1.70-1.66 (m, 1H), 1.65-1.57 (m, 4H), 1.37-1.22 (m, 12H), 0.94 (d, $J = 6.9$ Hz, 3H), 0.91-0.86 (m, 6H); ^{13}C NMR (126 MHz, CDCl_3): δ 174.1, 173.2, 110.3, 66.3, 65.3, 65.0, 64.8, 60.8, 42.3, 39.3, 35.7, 32.8 (2C), 28.8, 28.5, 27.8, 26.9, 25.7, 22.7 (2C), 17.5, 14.3 (2C); HRMS (ESI) calcd for $[\text{C}_{23}\text{H}_{42}\text{O}_6\text{Na}]^+$: 437.2874, found: 437.2857.

Ethyl 3-(3-hydroxy-1-oxocyclohex-2-en-2-yl)propanoate (**70**)

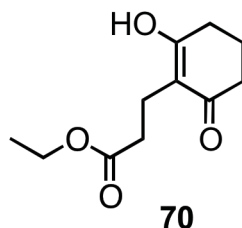

A solution of 1,3-cyclohexanedione (0.28 g, 2.5 mmol) in DMF (25 mL) was added to a suspension of sodium hydride (60% dispersion in mineral oil) (100 mg, 2.5 mmol) in DMF (25 mL). Ethyl acrylate (0.30 mL, 2.8 mmol) was then added to the mixture, and the stirred solution was heated to 80 °C under an N₂ atmosphere for 4 h. The solution was diluted with ethyl acetate (100 mL) and washed with H₂O (2 × 100 mL), which was re-extracted with ethyl acetate (50 mL). The combined organic layers was washed with aqueous 5% LiCl (100 mL) and with 0.5 M HCl (100 mL), dried over MgSO₄ and concentrated *in vacuo*. The residue was purified by flash chromatography (30% ethyl acetate in hexanes) to afford **70** (0.28 g, 53%) as a colourless solid: mp 129-131 °C; ¹H NMR (500 MHz, CDCl₃): δ 9.56 (s, 1H), 4.18 (q, *J* = 7.2 Hz, 2H), 2.57-2.55 (m, 2H), 2.52-2.49 (m, 2H), 2.46 (t, *J* = 6.3 Hz, 2H), 2.32 (dd, *J* = 9.1, 4.2 Hz, 2H), 1.91 (quintet, *J* = 6.5 Hz, 2H), 1.27 (t, *J* = 7.2 Hz, 3H); ¹³C NMR (126 MHz, CDCl₃): δ 198.9, 178.6, 173.6, 114.8, 62.0, 36.8, 33.3, 29.4, 20.6, 16.7, 14.2. These data match those in the literature.⁷²

Diethyl 5-oxononanedioate (71)

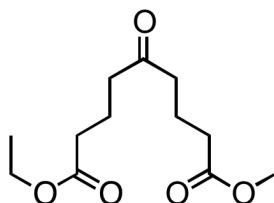

71

To a solution of keto-enol **70** (0.28 g, 1.3 mmol) in ethanol (10 mL) was added conc. HCl (1 mL). The stirred solution was heated under reflux for 7 h. The solution was diluted with ethyl acetate (25 mL) then washed with water (2×10 mL), with brine (10 mL), dried over MgSO_4 and concentrated *in vacuo*. The residue was purified by flash chromatography (25% ethyl acetate in hexanes) to afford **71** (0.10 g, 30%) as a colourless oil: ^1H NMR (500 MHz, CDCl_3): δ 4.10 (q, $J = 7.1$ Hz, 4H), 2.54-2.52 (m, 4H), 2.32-2.30 (m, 4H), 1.89-1.86 (m, 4H), 1.22 (t, $J = 7.1$ Hz, 6H); ^{13}C NMR (126 MHz, CDCl_3): δ 209.4, 173.1, 60.5, 41.6, 35.2, 29.2, 14.3. These data match those in the literature.^{73,74}

Diethyl 5-(1,3-dioxolan-2-yl)nonanedioate (72)

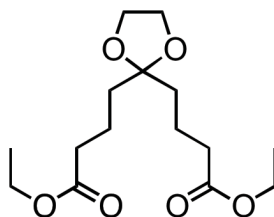

72

According to the procedure for **57**: ketodiester **71** (0.10 g, 0.40 mmol) was reacted with ethylene glycol (0.03 mL, 0.44 mmol) and *para*-toluenesulfonic acid (23 mg, 0.12 mmol) in benzene (4 mL) to yield, after flash chromatography (50% ethyl acetate in hexanes), **72** (97 mg, 80%) as a colourless oil: ^1H NMR (500 MHz, CDCl_3): δ 4.14-4.10 (m, 4H), 3.93-3.91 (m, 4H), 2.56-2.54 (m, 4H), 2.37-2.35 (m, 4H), 1.93-1.90 (m, 4H), 1.23 (m, 6H); ^{13}C NMR (126 MHz, CDCl_3): δ 173.1 (2C), 113.2, 65.3 (2C), 60.5 (2C), 41.6 (2C), 35.2 (2C), 29.2 (2C), 14.3 (2C); HRMS pending.

Chapter 3 – Nazarov Reactions Intercepted by (4+3) Cycloadditions with Oxygen-Substituted Dienes

3.1 Introduction

The Nazarov reaction, named after Ivan Nikolaevich Nazarov who first reported the reaction in 1941,⁷⁵ is a 4π electrocyclic reaction that converts divinyl ketones into cyclopentenones.^{6,76-78} The reaction is mediated by a Brønsted or Lewis acid, which generates a pentadienyl cation **77**, and ring-closure follows to form an oxyallyl carbocation **78**. A proton is eliminated from this intermediate to form an α,β -unsaturated cyclopentenone after tautomerization (Scheme 21).

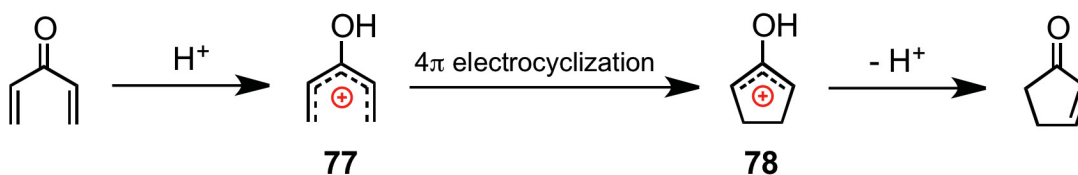

Scheme 21. The Nazarov reaction.

The 4π electrocyclization is a diastereospecific process that is governed by the Woodward-Hoffmann rules. The rules state that under thermal conditions, 4π electrocyclization will undergo conrotatory ring closure through the highest occupied molecular orbital (HOMO), while photochemical conditions dictate a disrotatory ring closure through the promotion of an electron to the lowest unoccupied molecular orbital (LUMO) (Scheme 22). The stereochemical outcome

of a Nazarov reaction is therefore predictable, which makes the reaction useful for making five-membered rings.

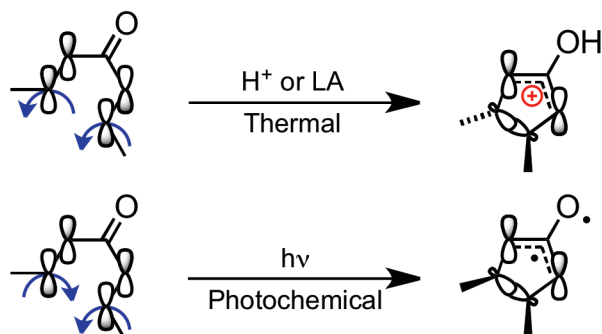

Scheme 22. Diastereospecificity of 4π electrocyclization.

There are many natural products that contain five-membered rings, and the Nazarov reaction could be applied to make carbocycles en route to the total synthesis of a natural product. One of the major drawbacks of the Nazarov reaction is that it usually requires harsh acidic conditions, which could be undesirable if other functional groups were present in the molecule. Milder conditions can induce cyclization if the divinyl ketone has α substituents. In order for cyclization to occur, the divinyl ketone must be in the *s*-trans/*s*-trans conformation (Scheme 23). Divinyl ketones with α substituents will favour an *s*-trans/*s*-trans conformation over *s*-cis/*s*-cis or *s*-cis/*s*-trans conformations.

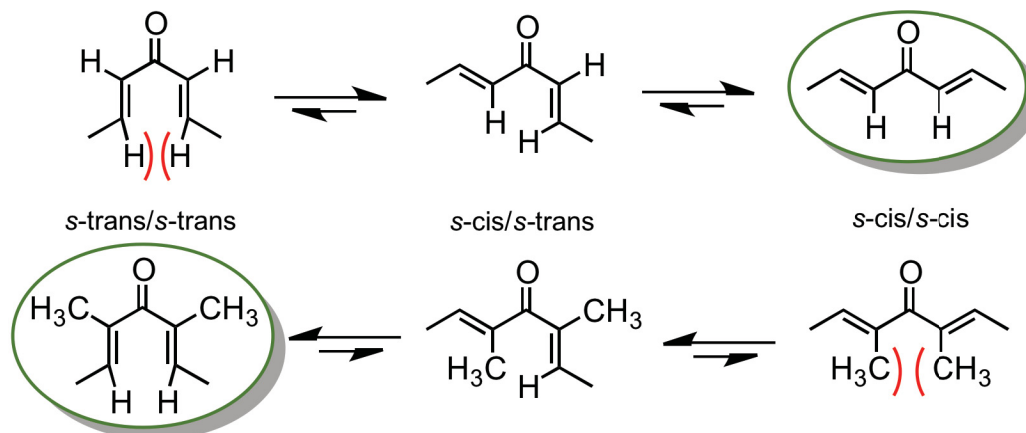

Scheme 23. The major conformations of divinyl ketones.

This phenomenon is due to the alleviation of a steric interaction that is presented in the *s-cis/s-cis* conformation. An α -substituent that also complexes with Lewis acids can also increase the *s-trans/s-trans* population.⁷⁹⁻⁸² This increase in the *s-trans/s-trans* population facilitates cyclization, and thus milder Lewis acids and lower temperatures can be used.

3.2 The Interrupted Nazarov Reaction

The interrupted Nazarov reaction takes advantage of the highly reactive oxyallyl cation intermediate by the introduction of a nucleophile to “interrupt” the proton elimination step, and instead form a new sigma bond. The term was coined by Dr. Fred West and coworkers,⁸³ who have contributed significantly to the scope of this type of reaction. Oxyallyl cations were trapped by alkenes either by forming one new carbon-carbon bond, or by forming two new carbon-carbon bonds via (3+2) cycloaddition (Scheme 24).⁸⁴⁻⁸⁷ (4+3) Cycloadditions were also observed with dienes. Oxyallyl cations were trapped by arenes by means of a Friedel-Crafts

alkylation,^{88,89} halides after dissociating from the Lewis acid,⁹⁰ and hydride, in a process known as the reductive Nazarov reaction.⁹¹

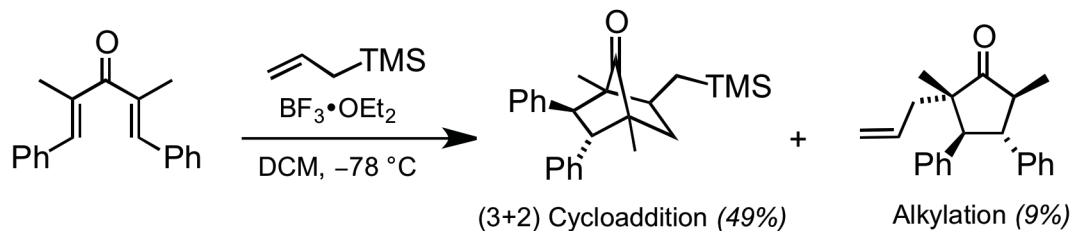

Scheme 24. An interrupted Nazarov reaction with an alkene.⁸⁴

3.3 Nazarov Reactions with Allenyl Vinyl Ketones

Allenyl vinyl ketones (AVKs) are more reactive than divinyl ketones. Hashmi *et al.*⁹² were the first to report Nazarov cyclizations with AVKs in 1998. They showed AVKs to be more reactive than divinyl ketones, as cyclization of AVKs occurred spontaneously on silica gel during column chromatography (Scheme 25). This enhancement in reactivity was likely due to a number of factors, which included the release of allenic strain on the *sp*-hybridized central carbon during cyclization, and the reduced steric repulsion on the vinylic hydrogen when in the *s*-trans/*s*-trans conformation.

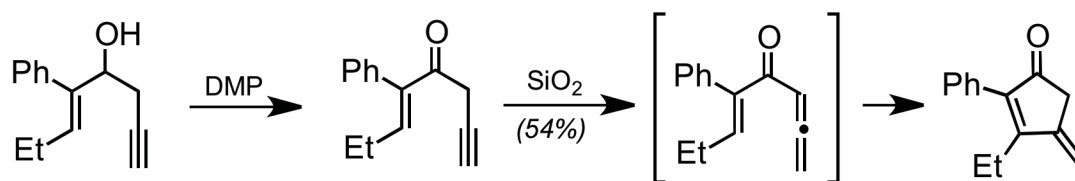

Scheme 25. The silica gel-mediated Nazarov cyclization of an AVK.

Nazarov cyclizations of AVKs are facilitated by a lower energy oxyallyl cation intermediate compared to that from a divinyl ketone. The cationic intermediate from an AVK **79** has the added stability of an additional resonance contributor arising from an exocyclic double bond, which is not present in oxyallyl cations of divinyl ketones **78** (Scheme 26).

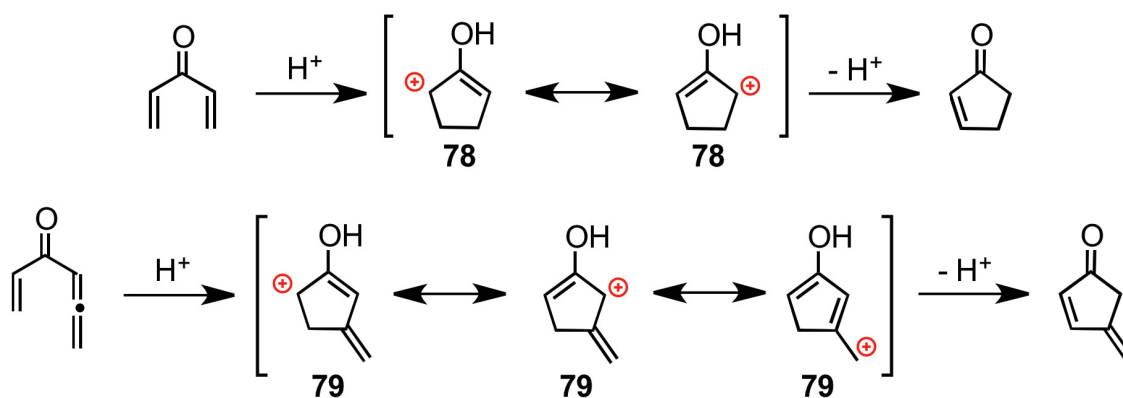

Scheme 26. The resonance contributors of oxyallyl cation intermediates.

3.4 Interrupted Nazarov Reactions of AVKs

3.4.1 Mono-Additions to Oxyallyl π -Systems

AVKs seem better suited for interrupted Nazarov reactions as the oxyallyl cation should be longer lived. Nucleophilic addition could potentially occur on one of three carbons of the delocalized carbocation (Figure 5). Computational studies have shown position *a* to be the most nucleophilic site,⁹³ however there have been instances of trapping at position *c* and, very much less often, at position *b*.

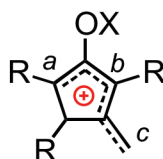
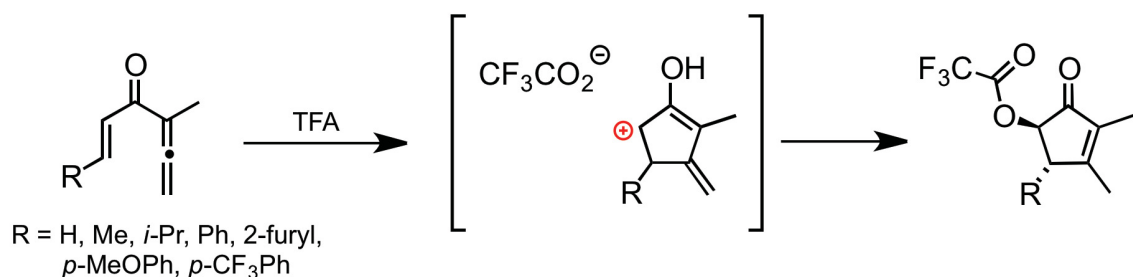

Figure 5. Potential trapping sites of an oxyallyl cation.

Trifluoroacetic acid (TFA) has been shown to both promote cyclization and to provide a nucleophile.⁹⁴ The results of Nazarov reactions in the presence of TFA showed only trapping at position *a* along with isomerization of the exocyclic double bond to form the more stable conjugated cyclopent-2-enone (Scheme 27).



Scheme 27. An interrupted Nazarov reaction with TFA.

The oxyallyl cations from AVKs were also reacted with halides as nucleophiles.⁹⁵ Trapping was observed primarily at position *a* but also sometimes at *c*, depending on the Lewis acid used. When AuCl₃ was used with AVK **80**, the cyclopentenone product **81** was observed, trapping the oxyallyl cation at position *a*. When titanium tetrachloride was used, AVK **80** was rapidly consumed, but only intractable material was obtained. Titanium tetrabromide gave mixed results with different AVKs, but with AVK **80** it exclusively formed a product **82** that had trapped at position *a*. Titanium tetraiodide, however, formed cyclopentenone **83**, which was not only a product of Nazarov cyclization but also a reduction. It is likely this was a result of deiodination of an α -iodocyclopentenone.⁹⁰ Indium(III) halides consistently provided cyclopent-2-enones with nucleophilic addition exclusively at position *c*, producing **84**, **85**, and **86**, albeit in low yield (Scheme 28).

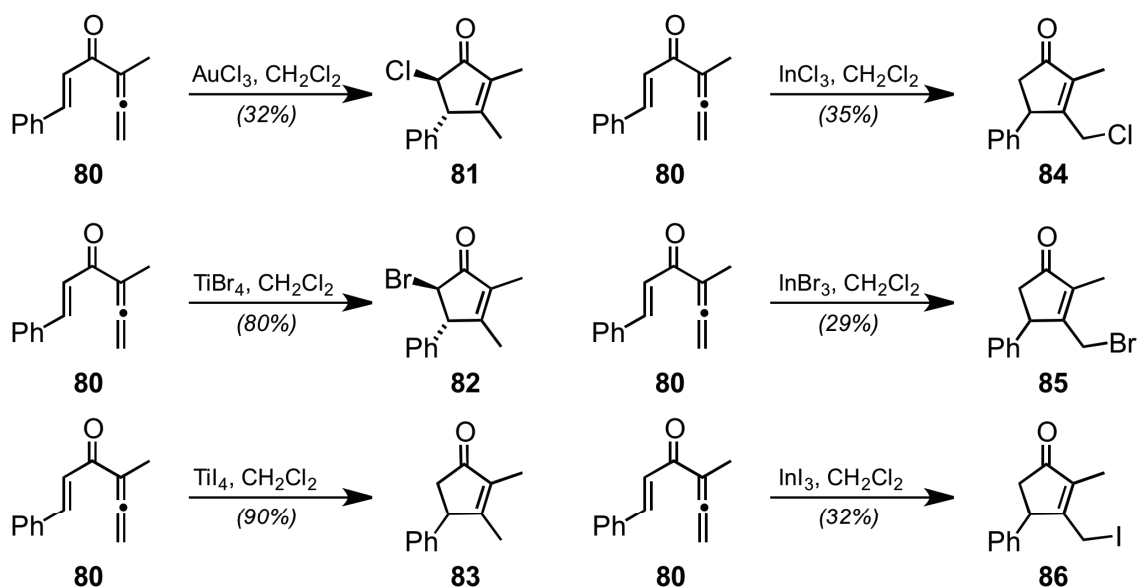

Scheme 28. Interrupted Nazarov reactions using halogen nucleophiles.

Nitrogen-based heterocycles intercepted Nazarov reactions of AVKs to give cyclopent-2-enones trapped at positions *a* and *c*.⁹⁶ *N*-Alkyl-, *N*-aryl- and *N*-silyl-substituted pyrroles were trapped highly regioselectively and gave products trapped only at position *a*, but only modest selectivity was observed when electron-withdrawing acyl or sulfonyl groups were bonded to the nitrogen of pyrrole (Scheme 29). Indoles were capable of trapping much more efficiently than pyrroles, and regioselectivity depended on the substitution near the reacting carbons. The results are in accord with the computational results that suggest position *a* is the electronically preferred trapping site,⁹³ and position *c* must be the sterically preferred trapping site.

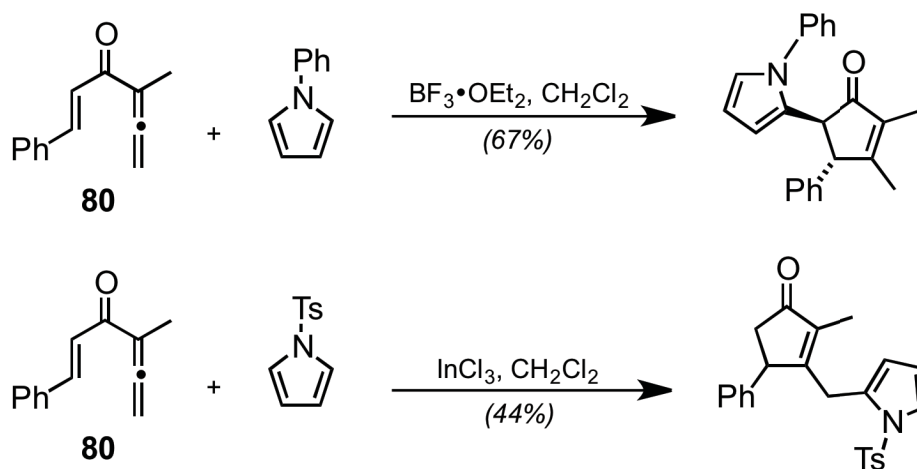

Scheme 29. Interrupted Nazarov reactions with *N*-substituted pyrroles.

These results corroborate a previous study that used other cyclic dienes.⁹⁷ Using the same AVK **80**, furan trapped primarily at position *a*, with a minor product trapped at position *c*. 1,3-Cyclohexadiene trapped only at position *a* forming **87**, and the bulkier 1,2,3,4,5-pentamethylcyclopentadiene trapped primarily at position *c* to form **88** (Scheme 30).

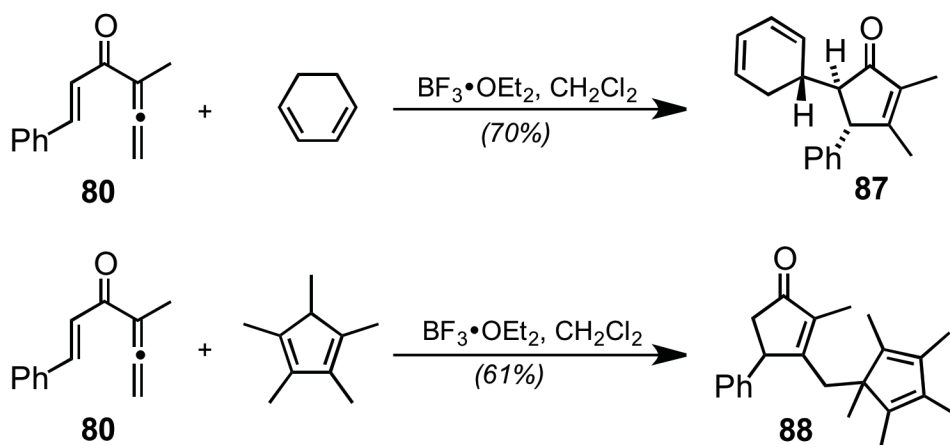

Scheme 30. Interrupted Nazarov reactions with cyclic dienes.

Trapping at position *b* has only been observed when an ambiphilic molecule was used, acting as both a Lewis acid and nucleophile.⁹⁸ When AVK **80** was reacted with $(\text{Me}_2\text{AlCH}_2\text{PMe}_2)_2$ at rt for 40 min, a 3:7 mixture of **89** and **90** was observed by NMR spectroscopy. However, after 20 h, complete conversion to **90** was observed (Scheme 31).

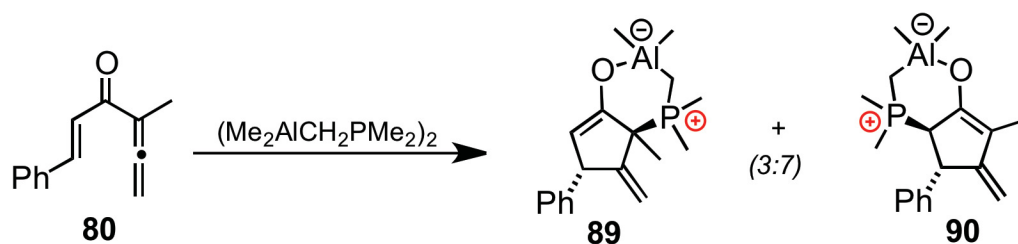

Scheme 31. Nazarov cyclization with an ambiphilic molecule.

3.4.2 Bis-Additions to Oxyallyl π -Systems

Acyclic dienes when reacted with **80** did not produce products trapped at positions *a* or *c*, but rather formed two carbon-carbon bonds across positions *a* and *b*.^{93,97} These products were either (4+3) cycloadducts, where the four sp^2 carbons of the diene participated in a cycloaddition with the three sp^2 carbons of the oxyallyl cation, or (3+2) cycloadducts, where only one double bond of the diene participated in the cycloaddition reaction. When different AVKs were used, only (4+3) cycloadducts were observed (Scheme 32).⁹³ This tandem Nazarov cyclization / cycloaddition strategy would be useful in the synthesis of natural products that contain [4.2.1] or [2.2.1] bicyclic ring systems.

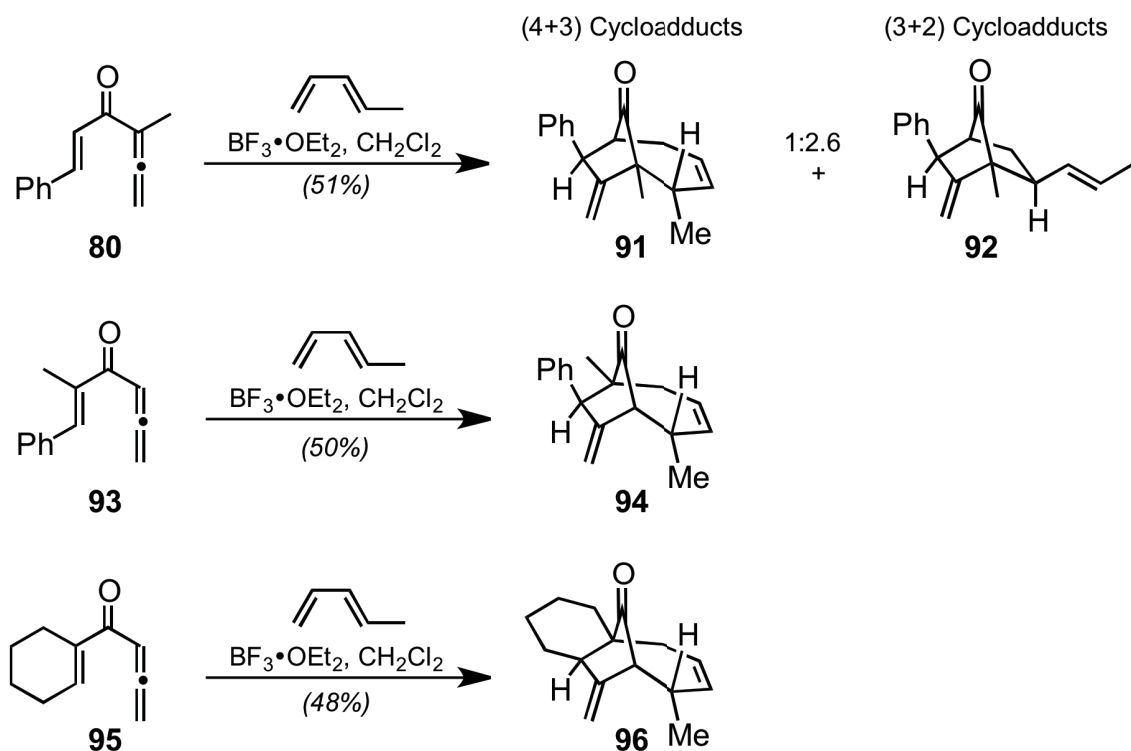

Scheme 32. Interrupted Nazarov reactions with acyclic dienes.

Although with some dienes AVK **80** showed modest (4+3) versus (3+2) selectivity, the regioselectivity of the trapping reactions was usually high. The electron-rich terminus of the diene formed a carbon-carbon bond with the most nucleophilic terminus of the delocalized oxyallyl cation. Diastereoselectivity was high in some instances, but the interrupted Nazarov reactions of **80**, **93**, and **95** with *trans*-piperylene gave **91**, **92**, **94**, and **96** as single diastereomers.

Divinyl ketones are also capable of trapping nucleophiles by (4+3) cycloadditions.⁸⁷ 2,3-Dimethylbutadiene was used to trap the oxyallyl cation of divinyl ketone **97** to produce a (4+3) adduct **98** in 50% yield after 3 h at -78 °C.

When the same diene was used with AVK **80**, the (4+3) cycloadduct **99** was produced in nearly quantitative yield in only five min at $-78\text{ }^{\circ}\text{C}$ (Scheme 33).⁹⁷

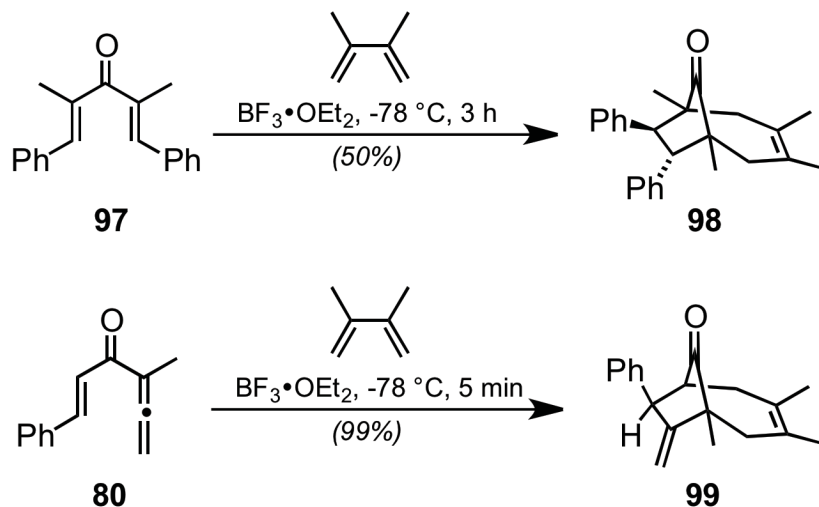

Scheme 33. (4+3) Cycloadditions with 2,3-dimethylbutadiene.

3.4.3 Interrupted Nazarov Reactions with Oxygen-Substituted Dienes

It was hypothesized that a strong π -donor like a silyl enol ether would have a great effect on the regioselectivity of the cycloaddition, but what was unknown was how this functionality would affect the (3+2) versus the (4+3) selectivity as well as the diastereoselectivity. When the Nazarov reaction was carried out with **80** in the presence of *trans*-1-methoxy-3-trimethylsilyloxy-1,3-butadiene, commonly known as Danishefsky's diene, intractable material was produced, with no trace of cycloadducts or alkylated minor products.⁹⁷ Therefore many butadiene analogs, but limited to only one oxygen function, were prepared and tested for cycloaddition onto the oxyallyl cation of AVK **80**.⁹⁹

3.5 Results and Discussions

3.5.1 Synthesis of the AVKs

The AVKs can be classified into three different types (Figure 6). Type 1 AVKs have an α -alkyl substituent on the allene moiety with β -vinylic substituents being phenyl **80**, methyl, isopropyl, *para*-methoxyphenyl, *para*-(trifluoromethyl)phenyl, furan-2-yl, and hydrogen. Only two Type 2 AVKs have been synthesized. One of which has an α -methyl substituent on the vinyl moiety with a vinylic phenyl group **93**; the other has two substituents fused as a cyclohexene ring **95**. The only Type 3 AVK synthesized to date has a phenyl substituent.

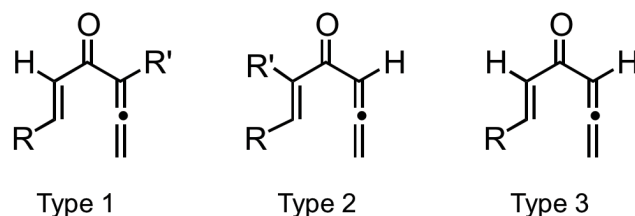
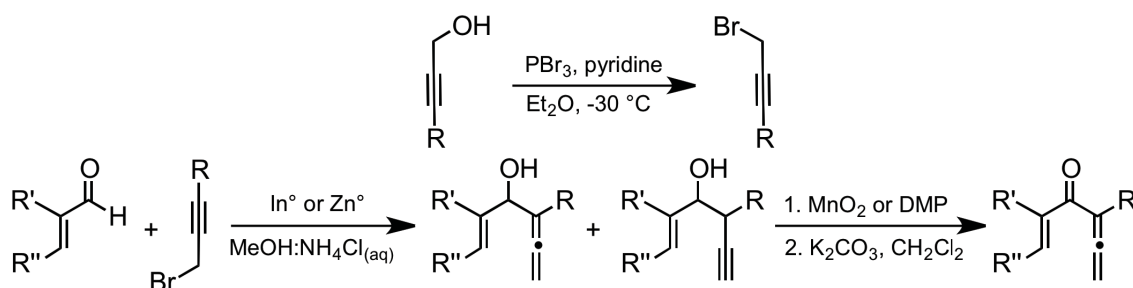

Figure 6. Type 1, Type 2, and Type 3 AVKs.

AVK **80** was chosen for the investigation of the trapping of an oxyallyl cation with a range of oxygen-substituted dienes. AVK **80** had been used in studies with other dienes, alkenes and heterocycles.⁹³⁻⁹⁸ It is more stable than the majority of other AVKs, so it can be prepared on a relatively large scale and stored at $-20\text{ }^{\circ}\text{C}$ over many months. AVK **80** has a methyl substituent on the allene moiety that provides some steric protection for the allene central carbon and probably helps to

mitigate unwanted Michael reactions. Two more AVKs were also prepared to see if the observed stereochemical trends held true for other substrates. They were both Type 2 AVKs, **93** and **95**.

The AVKs were synthesized in three or four steps. The first step was to brominate commercially available propargyl alcohol with PBr_3 . The second step was to couple this bromide with an α,β -unsaturated aldehyde. Using zinc provided the allene, whereas indium provided a mixture of the allene and the alkyne, albeit in better total yield. The third and fourth steps were to oxidize the resulting allylic alcohol and to isomerize the alkyne to the allene when necessary. This method produced **80** in 35% overall yield from the propargyl alcohol. AVKs **93** and **95** were not at all as stable as **80**, thus their alcohol precursors were prepared and stored, and only oxidized/isomerized immediately before the initiation of the Nazarov cyclization.



Scheme 34. Synthesis of AVKs.

3.5.2 Synthesis of Dienes

Two types of oxygen-substituted dienes were prepared for this study. The first type were trimethylsilyl- (TMS) trapped enolates of α,β -unsaturated ketones. The second type were *tert*-butyldimethylsilyl- (TBS) trapped enolates of α,β -unsaturated ketones.

TMS-trapped enolates were synthesized following a procedure by Jung and McCombs,¹⁰⁰ but with some modifications. Triethylamine was used to form the enolate and chlorotrimethylsilane (TMSCl) was used to trap the anion. Four dienes **100a-d** were prepared by this method (Table 3).

Table 3. Preparation of TMSO-substituted dienes 100a-d.

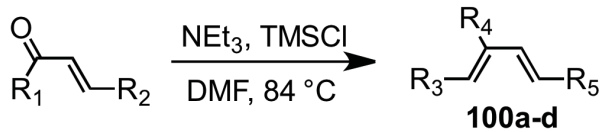
|  | | | | | | | |
|--|---------------------------------|-----------------|-----------------|----------------|-----------------|-------------|-----------------|
| Entry | R ₁ | R ₂ | R ₃ | R ₄ | R ₅ | Product | % Yield |
| 1 | CH ₃ | H | H | OTMS | H | 100a | 37 |
| 2 | CH ₃ | CH ₃ | H | OTMS | CH ₃ | 100b | 42 |
| 3 | CH ₂ CH ₃ | H | CH ₃ | OTMS | H | 100c | 21 |
| 4 | H | CH ₃ | OTMS | H | H | 100d | 15 ^a |

^a Mixture of *E,E* and *E,Z* diene.

Attempts at making TBS-trapped enolates following the same procedure, but with TBSCl, failed. *tert*-Butyldimethylsilyl trifluoromethanesulfonate (TBSOTf) was instead used to trap the enolate using triethylamine or potassium hexamethyldisilazide (KHMDS) as the base.^{101,102} Nine dienes **101a-i** were prepared by this method (Table 4).

Table 4. Preparation of TBSO-substituted dienes 101a-i.

| Entry | R ₁ | R ₂ | R ₃ | R ₄ | Product | % Yield |
|-------|-----------------|--|-----------------|-----------------|-------------|-------------------|
| 1 | Me | H | H | H | 101a | 59 |
| 2 | Et | H | H | H | 101b | 75 ^a |
| 3 | <i>i</i> Pr | H | H | H | 101c | 92 ^a |
| 4 | Ph | H | H | H | 101d | 50 ^{a,b} |
| 5 | H | CH ₃ | H | H | 101e | 17 |
| 6 | H | H | CH ₃ | H | 101f | 73 |
| 7 | H | H | CH ₃ | CH ₃ | 101g | 90 |
| 8 | H | -CH ₂ (CH ₂) ₂ CH ₂ - | H | H | 101h | 90 |
| 9 | CH ₃ | H | CH ₃ | H | 101i | 50 ^a |

^a Yield obtained using KHMDS and TBSOTf in THF at -78 °C. ^b Product was a 1:1 mixture of *E* and *Z* isomers.

Attempts at making a 1,1-dimethyl-2-silyloxy-substituted butadiene were unsuccessful. Fortunately, a methoxy analog could be prepared in three steps

(Scheme 35). This method began with the formation of an acetal of acrolein, followed by an Arbuzov reaction to make a stabilized phosphonate.¹⁰³ The phosphonate then coupled with acetone via a Horner-Wadsworth-Emmons-type reaction to produce diene **101j**.¹⁰³

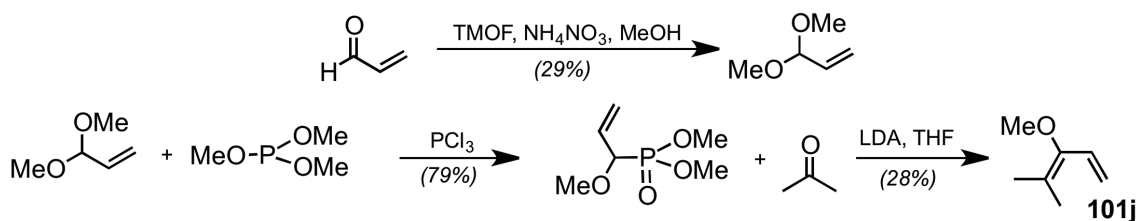

Scheme 35. Preparation of 101j.

3.5.3 Interrupted Nazarov Reactions

Following the same procedure used for the cycloaddition of acyclic dienes to oxyallyl cations from an interrupted Nazarov reaction of an AVK,⁹³ a series of (4+3) cycloadducts was synthesized using oxygen-substituted dienes.

Dienes **100a-c** formed (4+3) cycloadducts regioselectively and with high facial selectivity (adding to the face of the oxyallyl cation opposite the phenyl) when reacted with AVK **80** (Scheme 36). Dienes **100d** produced a complex mixture of intractable products. The products of dienes **100a-c** were largely desilylated during the reaction and so mixtures of products were observed. Unsubstituted diene **100a** gave a 1:1 mixture of silylated **102** and desilylated **103** products in a 51% combined yield favouring the (4+3) over the (3+2) or mono-addition pathways. A methyl substituent γ to the oxygen of the diene **100b** led to (4+3) products with

high diastereoselectivity, favouring products where the methyl substituent was *anti* (or “down” as shown in Scheme 36) with respect to the bridging carbonyl **104** and **105**, but the yields were lower. Some mono-addition product **106** was also obtained. A methyl substituent β to the oxygen (on the opposite end of the diene) as in diene **100c** provided (4+3) products exclusively and in a combined 95% yield, however, the diastereoselectivity in this example was lower than with **100b** forming a 5:1 mixture of silylated products **107a,b** and 1.2:1 mixture of desilylated products **108a,b**. The major diastereomer of **107** had the methyl *syn* (or “up” as shown in Scheme 36) with respect to the bridging carbonyl, while the major diastereomer of **108** had the methyl *anti* (“down”) with respect to the bridging carbonyl.

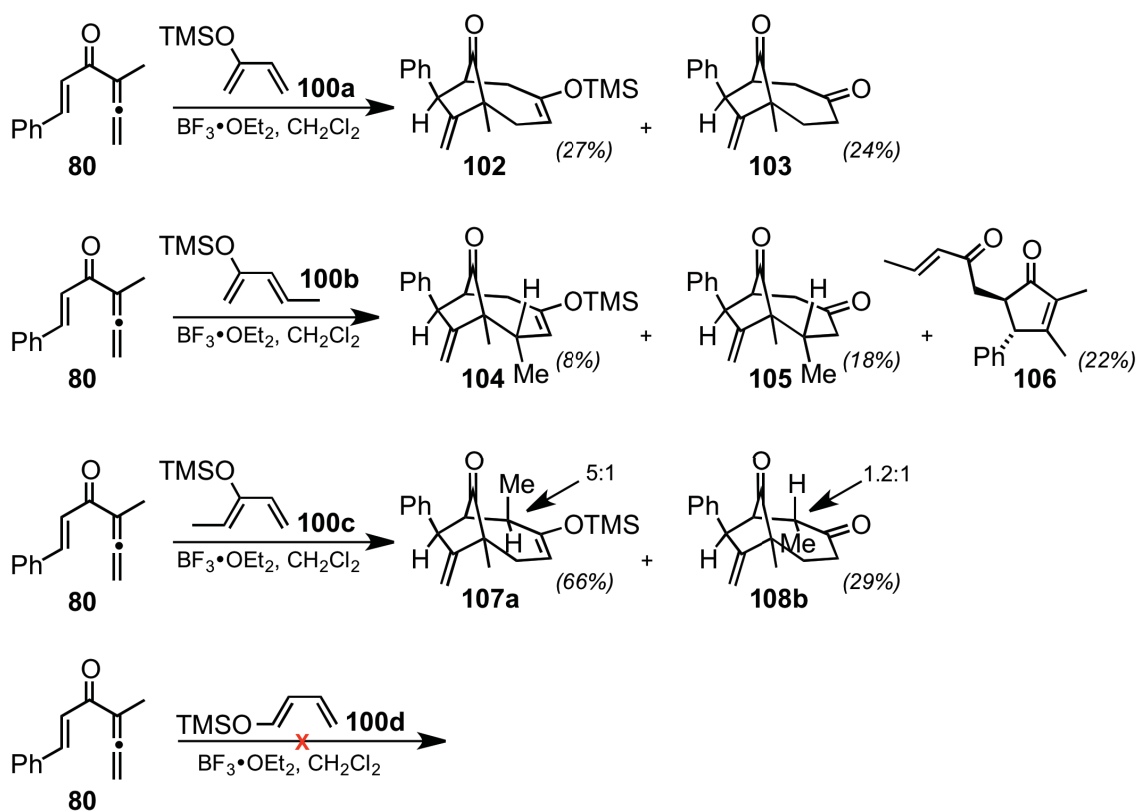

Scheme 36. Formation of (4+3) cycloadducts using 100a-c.

The relative stereochemistry of these diastereomers was determined by NOE experiments. Irradiation of the more deshielded hydrogen of the exocyclic double bond in **104** and **105** showed enhancements for the methyl doublet signal, while irradiation of the benzylic hydrogen in **107a,b** and **108a,b** showed enhancements for the substituent that is *anti* to the carbonyl (Figure 7).

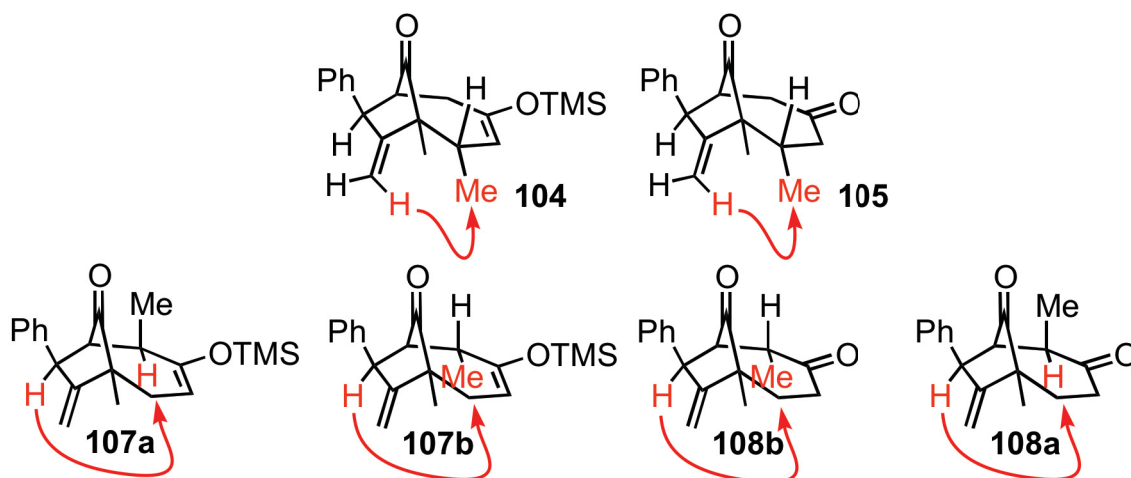
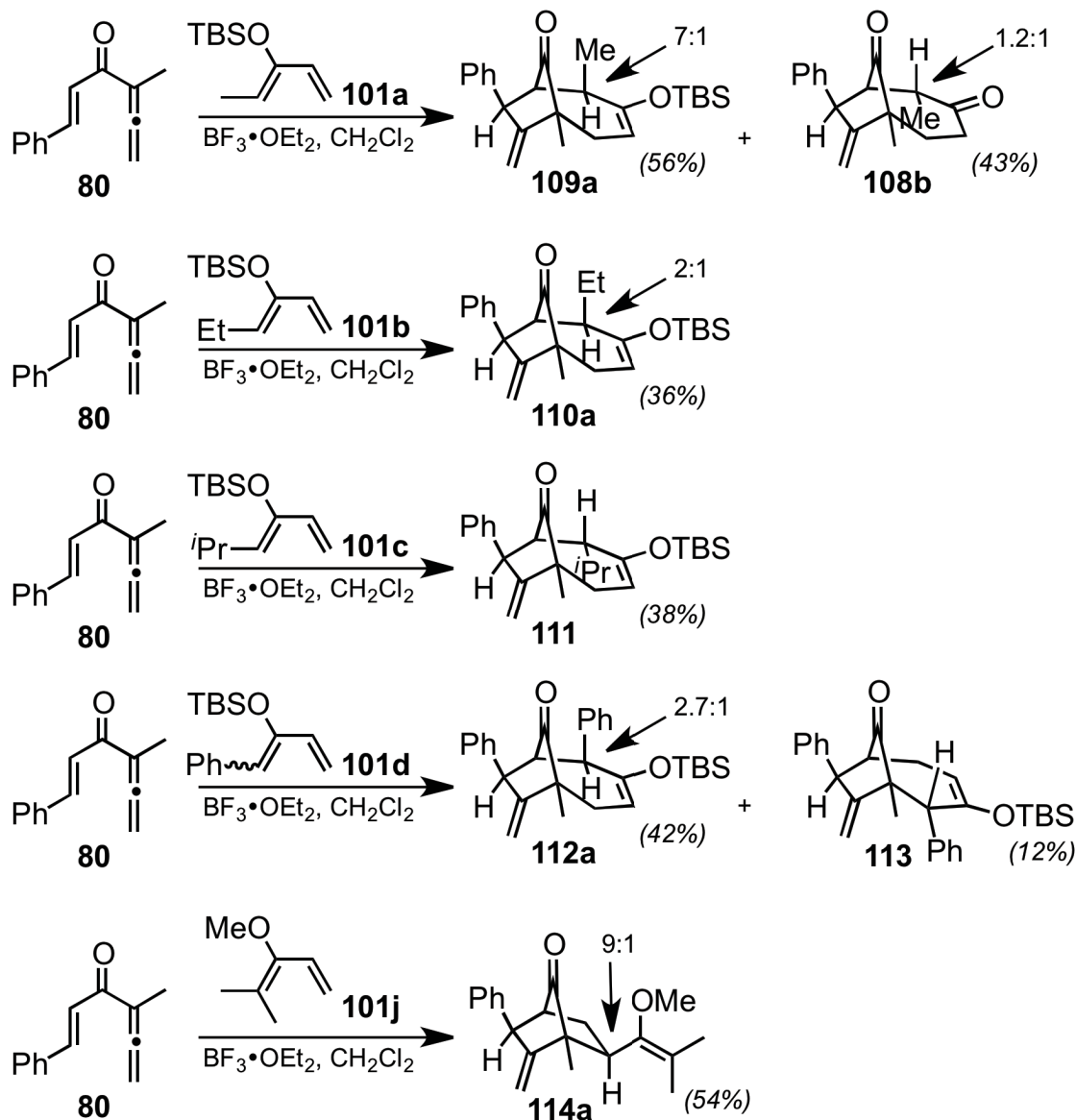

Figure 7. Stereochemical assignments of Nazarov products using NOE.

Desilylation of these products posed a problem with analysis. It was not obvious whether the discrepancy in the diastereomeric ratios of **107a,b** and **108a,b** was due to an epimerization of the methyl group since it was α to a carbonyl, or if **107b** simply desilylated faster than **107a**. It was hoped that TBSO-substituted dienes would be more robust than their TMSO-counterparts and that desilylation would not occur. This was true for most cases except diene **101a**, which still produced **108a,b** along with **109a,b**. The results with this diene were similar to those of **100c** as the reactions were both high yielding and the diastereomer that was formed preferentially was the one with a methyl in the “up” position, but preferentially “down” in the desilylated product (Scheme 37).



Scheme 37. Nazarov reactions of AVK **80 in the presence of dienes **101a-d** and **101j**.**

Three other dienes with substituents on the same carbon of the diene as **101a** were also investigated. The ethyl-substituted diene **101b** reacted regioselectively forming **110a,b**, where **110a** was the major diastereomer bearing an ethyl group that was “up” as shown in Scheme 37. The slightly bulkier isopropyl-substituted diene **101c** reacted with the same regioselectivity as the

previous two dienes but had the opposite diastereoselectivity. The only product isolated, **111**, had the isopropyl group “down”. The structure of **111** was verified by X-ray crystallography (Figure 8).^{*} Diene **101d** was obtained as an inseparable 1:1 mixture of *E* and *Z* isomers, but the ¹H NMR spectrum of the crude reaction mixture with AVK **80** showed that only the *Z* isomer had reacted. It appeared that the cation-stabilizing ability of the phenyl group competed with the electron-donating ability of the silyloxy group and the (4+3) products **112a,b** were accompanied by a lesser amount of **113** with the regiochemistry reversed. Diene **101j** contained geminal methyl substituents on the more nucleophilic carbon of the diene, which prevented the formation of a (4+3) cycloadduct, presumably due to steric hindrance, and formed a 9:1 mixture of (3+2) products instead. The relative stereochemistry for all compounds was determined by NOE experiments.

^{*} X-ray crystal structures were provided by Dr. T. S. Cameron.

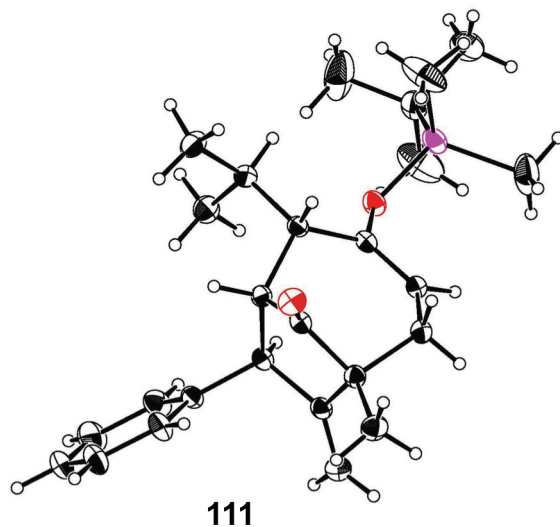
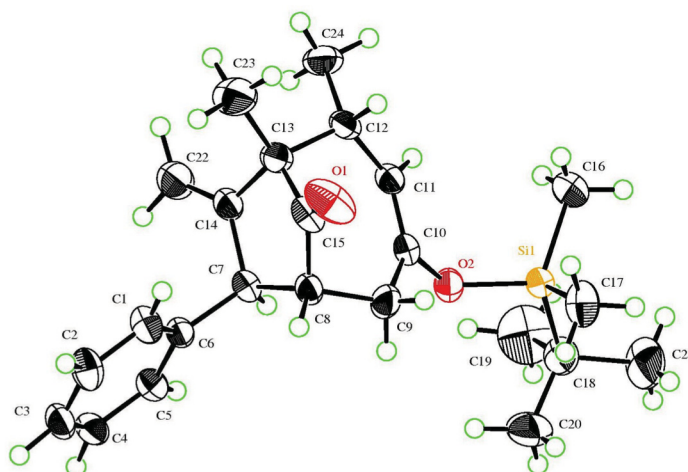

Figure 8. ORTEP of 111.

Dienes **101e-h** had substituents on the other carbon-carbon double bond of the diene. These four dienes formed (4+3) products with a high degree of regioselectivity and diastereoselectivity (Scheme 38). Consistent with the result of the Nazarov product trapped with **100b**, products **116** and **118** bore alkyl substituents that had an *anti* relationship with the bridging carbonyl. This high degree of stereoselectivity was in contrast with examples of modest stereoselectivity in the (4+3) cycloadditions onto oxyallyl cations.^{86,104-107} The yield of **116** was modest, but it was accompanied by a larger amount of **106**. The structure of **116** was also confirmed by X-ray crystallography (Figure 9).



116

Figure 9. ORTEP of 116.

Diene **101g** bore two geminal methyl groups on the carbon that was γ to the oxygen and reacted with the oxyallyl cation of **80** to form **117**. This was especially noteworthy because similar dienes without an oxygen functional group gave (3+2) products exclusively.^{97,108}

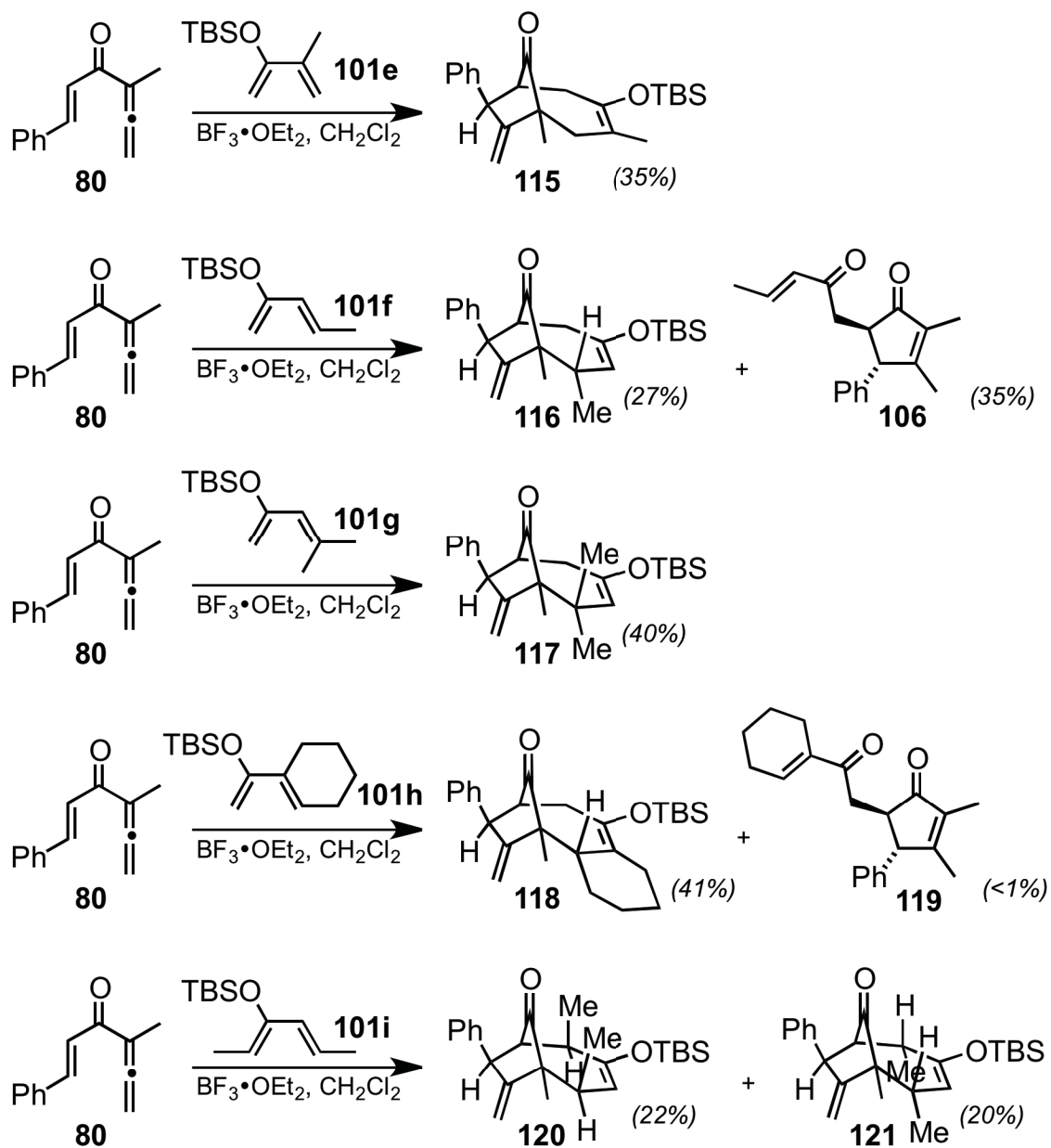

Scheme 38. Nazarov reactions of AVK **80 in the presence of dienes **101e-i**.**

Two equivalents (each) of dienes **101a** and **101f** were added to one equivalent of AVK **80**, to see if the oxyallyl cation was consumed faster by one diene or the other. The ^1H NMR spectrum of the crude reaction mixture indicated trapped Nazarov products **116:106:109a:109b** were formed in a ratio of 1:3.5:8:2,

respectively. Therefore, although diene **101a** gave a higher yield of tandem product compared to diene **101f**, diene **101a** reacted with the oxyallyl cation only slightly faster than did diene **101f**. This would imply that diene **101i**, with substituents on both termini of the diene, would be subject roughly equally to the phenomena at either end of the diene that controlled the stereochemical outcome. When AVK **80** was cyclized and its oxyallyl cation was trapped with **101i**, a mixture of diastereomers was produced in nearly equal quantities (Scheme 38). Cycloadduct **120** had both methyl groups in the “up” orientation, while **121** had them both “down”; no *trans* product was observed.

To check whether or not the observed selectivities would also be evident with other oxyallyl cations, two more AVKs were prepared for this study. Because these molecules are quite reactive, they needed to be prepared immediately before use and used without purification. The yields of the (4+3) products are thus calculated over three steps (oxidation, isomerization and cyclization) from the corresponding alcohol precursors of the AVK. The Nazarov reactions of AVK **93** were carried out in the presence of dienes **101a** and **101g**, forming (4+3) trapped products exclusively (Scheme 39). In the case of **101a**, the opposite regioselectivity was observed with respect to the oxyallyl cation of **80**, and the product favoured the diastereomer that bore the methyl group “up”. Diene **101g**, however, produced an adduct with the expected regioselectivity, and it was obtained as a single diastereomer. AVK **95** was reacted with **101a** to form a desilylated product in extremely low yield; however, it was interesting to note that the diene added the

same way as it did with **93** to form an analogous regioisomer, but the stereoselectivity for the opposite diastereomer of **93**.

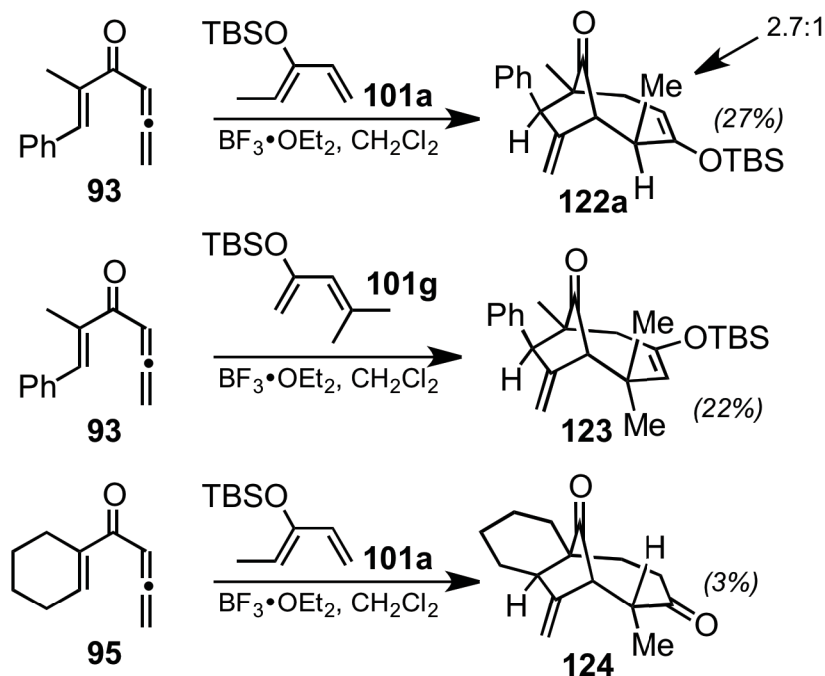

Scheme 39. Nazarov reactions with AVKs 93 and 95.

There is some debate over whether or not (4+3) cycloadditions of oxyallyl cations are concerted or stepwise. The formation of **106** and **119** could arise from a stepwise mechanism, where the second bond was not formed, possibly due to steric hindrance between the methyl and alkyl groups (Scheme 40). It is also possible that the (4+3) products could arise from an equilibration process as was demonstrated when (3+2) products were resubjected to acidic conditions.^{93,108} Some of the products from this study were treated again with $\text{BF}_3 \cdot \text{OEt}_2$ to see if they would equilibrate to form single diastereomers or new constitutional isomers.

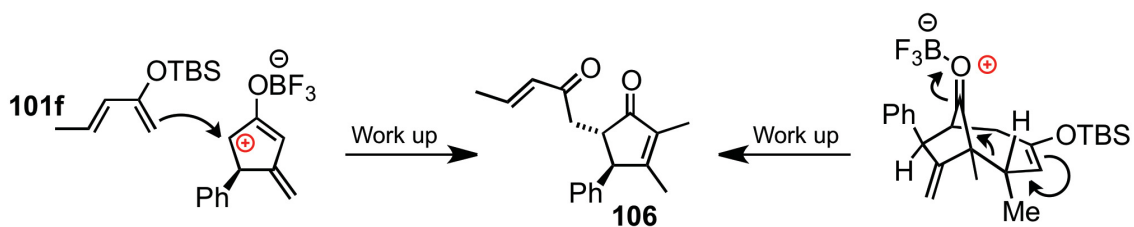

Scheme 40. Possible mechanisms for the formation of 106.

When **116** was resubjected to acidic conditions, complete conversion to **106** was observed (Scheme 41). Therefore, a few more (4+3) products were resubjected to the same conditions. A 7:1 diastereomeric mixture of **109a,b** was simply desilylated to **108a,b** when resubjected to $\text{BF}_3 \cdot \text{OEt}_2$, but it was important that the diastereomeric ratio was unchanged during desilylation. Therefore, the diastereoselectivity of the trapping reaction was very likely to have not been altered by epimerization following desilylation. The isopropyl-substituted (4+3) cycloadduct **111** was also resubjected to these conditions as it had its substituent in the “down” orientation. The product was desilylated without fragmentation, and the relative stereochemistry of the isopropyl-substituted center had not changed.

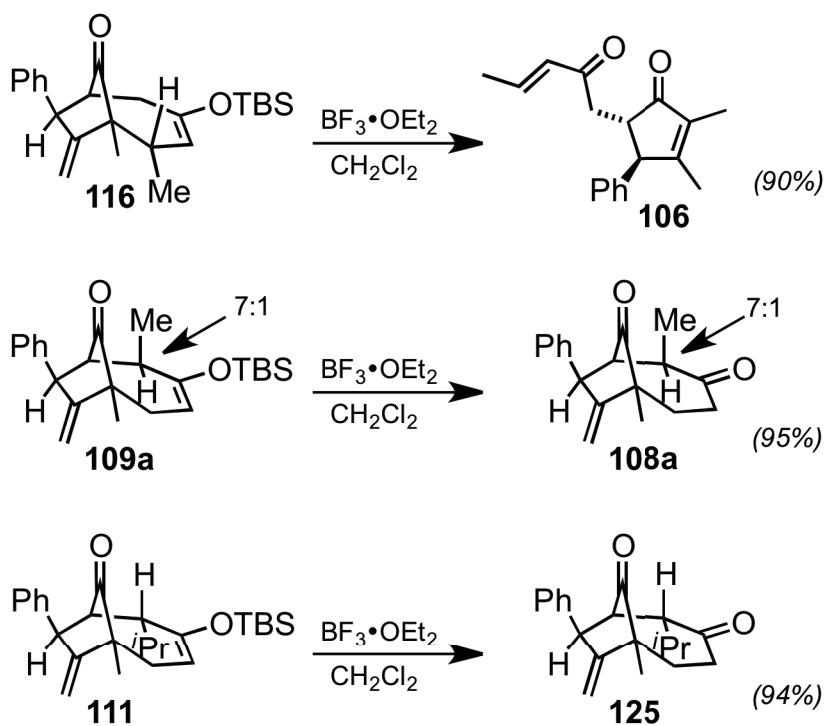

Scheme 41. Acid treatment of 116, 109a,b and 111.

Cycloadducts **120** and **121** were also allowed to equilibrate (Scheme 42). The results of this were two desilylated products **126** and **129**, two ring opened products **127** and **130**, and two bicyclo[5.2.1]decenedione products **128** and **131**. It is important to note that the ring opening and desilylation products did not show any epimerization, and ring closure onto the exocyclic double bond of the cationic intermediate occurred diastereoselectively.

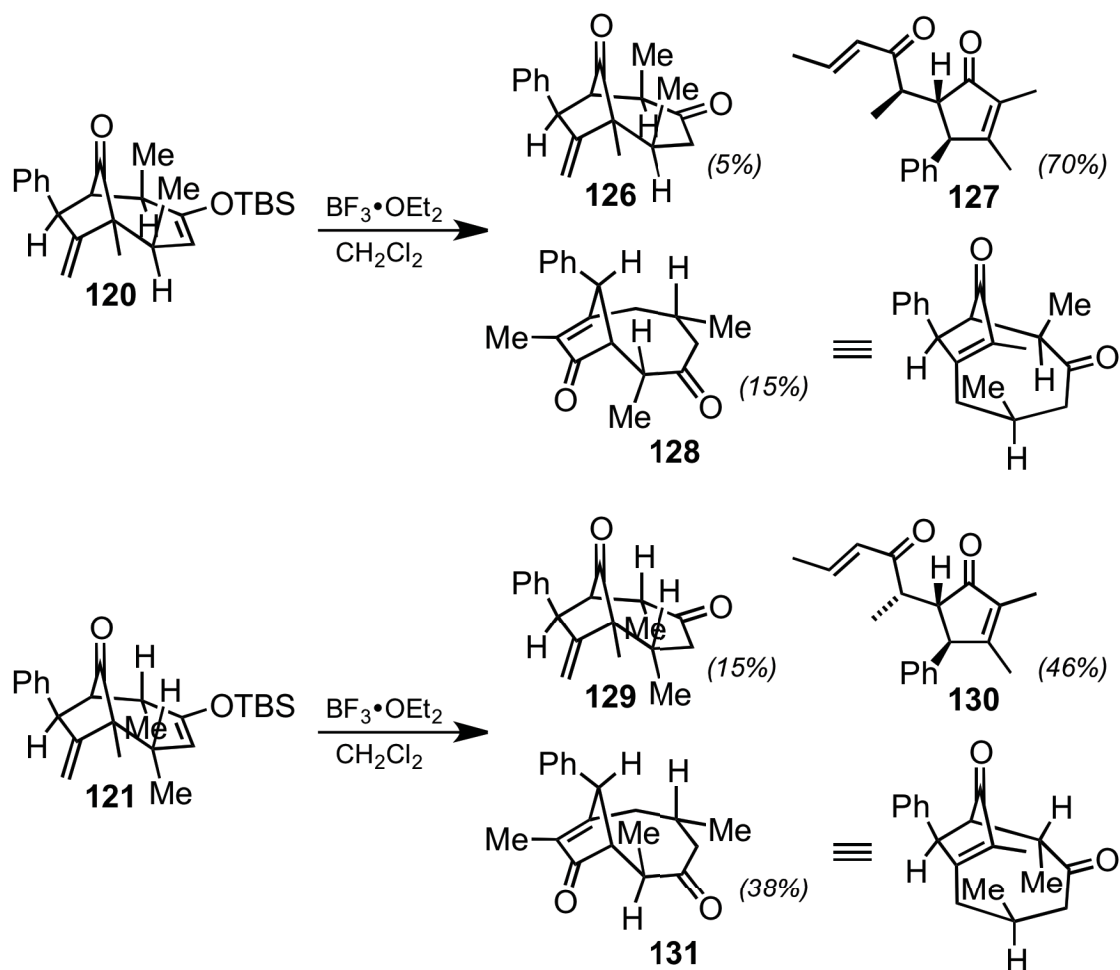

Scheme 42. Acid treatment of 120 and 121.

The results of these reactions suggest that the alkyl substituents that end up α to the carbonyl do not epimerize, and therefore the diastereoselectivity must come from the initial carbon-carbon bond formation of the (4+3) process. Substituents that end up β to the carbonyl have a carbon-carbon bond to quaternary center, which is sufficiently labile to break under acidic conditions. There is no significant reclosure onto this quaternary center, so it would be very likely that the initial bond was formed in a concerted (4+3) process.

The observed diastereoselectivity can be rationalized by an asynchronous but concerted transition state in which the shorter incipient bond is the one formed between the electron-rich terminus of the diene and the most electrophilic carbon of the oxyallyl cation (Scheme 43). Dienes that were substituted on the carbon that is β to the oxygen, i.e., **101a-d**, preferred to react through a compact transition state **132C** forming **134a** predominantly, except for the diene that bore a larger isopropyl group **101c**, which formed **134b** exclusively via an extended transition state **132E**. The reason why **132C** appeared to be the more favourable transition state could be due to the steric influence of the benzylic hydrogen in **132E**. In the case of **101c**, the isopropyl group might have an unfavourable interaction with the hydrogen of the carbocation in **132C** that is minimized in **132E**.

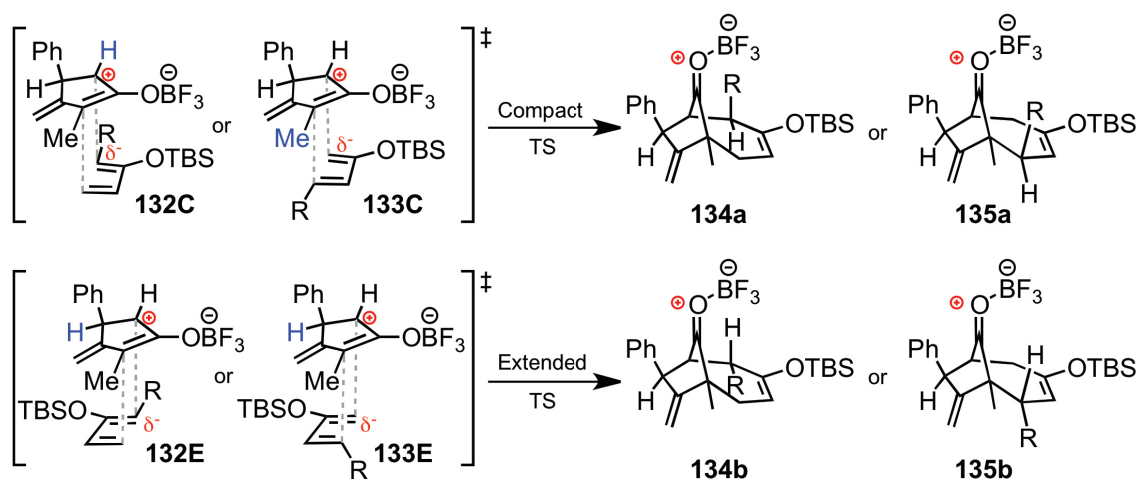

Scheme 43. Compact and extended transition states of the (4+3) cycloaddition.

The same phenomena would hold true for reactions taking place with dienes substituted on the carbon γ to the oxygen, i.e., **101f-h**. The compact transition state **133C** would be disfavoured due to the steric influence of the methyl group on the

oxyallyl cation. Instead, the dienes would react through an extended transition state **133E** forming **135b** exclusively. Both dienes **101g** and **101j** have two geminal methyl substituents on the γ carbon and the β carbon of the diene, respectively. Diene **101g** gave a product of type **135**, while diene **101j** produced a (3+2) cycloadduct. The difference between the two was that the methyl substituents on **101j** would have a larger steric influence due to their proximity to the oxyallyl cation, as they are located on the carbon that has the shorter incipient bond, whereas the incipient bond to the dimethyl substituted carbon of **101g** is longer. Diene **101i** also bears two methyl substituents, but they are on opposite termini of the diene. The result of its cycloaddition to the oxyallyl cation of **80** was a nearly equal amount of products arising from each transition state.

The steric influence of the methyl group of the oxyallyl cation was further exemplified during the interrupted Nazarov reaction of AVK **93** and **95** (Scheme 44). The alkyl substituents on the most electrophilic carbon of the oxyallyl cation made transition states **136** and **137** too high in energy, and thus the regioselectivity was reversed. Diene **101a** reacted predominantly with the oxyallyl cation of **93** via the compact transition state **138C** (for the same reasons it did with the oxyallyl cation of **80**). However, **101a** reacted with the oxyallyl cation of **95** exclusively via the extended transition state **140E**. This could be due to the enhanced steric effects of the cyclohexyl moiety. Diene **101g** reacted with the oxyallyl cation of **93** by the expected regioselectivity forming **143**.

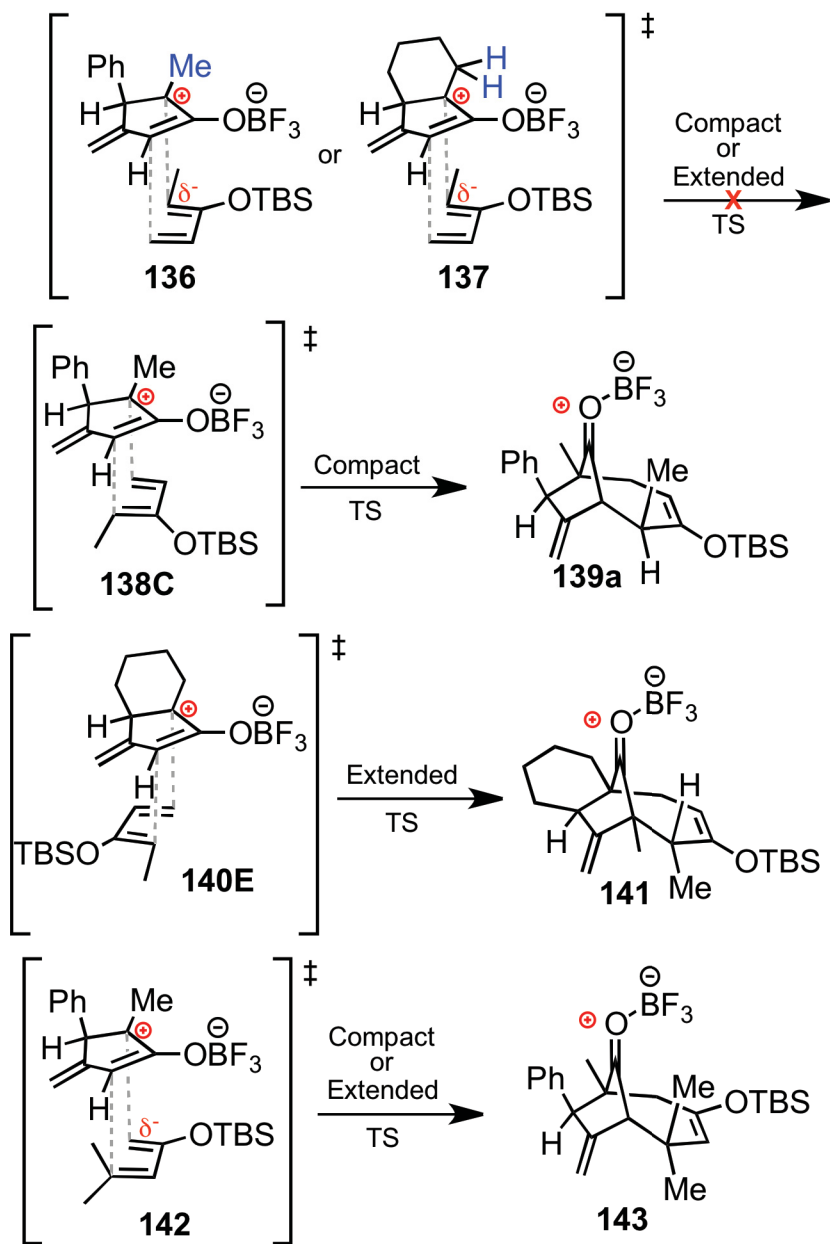

Scheme 44. The transition states of (4+3) cycloadditions with the oxyallyl cations from AVKs 93 and 95.

3.6 Conclusions and Future Work

The oxyallyl cations of AVKs have been shown to trap oxygen-substituted dienes exclusively by a (4+3) cycloaddition with the exception of one diene that trapped in a (3+2) process. These reactions occurred with high facial selectivity, high regioselectivity and high diastereoselectivity when the carbon γ to the oxygen on the diene was substituted; diastereoselectivity was modest when the carbon β to the oxygen of the diene was substituted. The (4+3) cycloaddition is concerted, with the compact transition state having a somewhat lower energy barrier than the extended one, although steric interactions from the diene and the oxyallyl cation can influence this selectivity. These results will be tested with computational studies that are currently underway.

Future work for this project would be to examine the trapping ability of sulfur containing dienes, mainly thiophenes. Pyrroles and furans have been shown to trap the oxyallyl cation of AVK **80** via a Friedel-Crafts reaction forming products that had trapped at position *a* and *c* depending on the electronic and steric influences of substituents on these aromatic molecules.

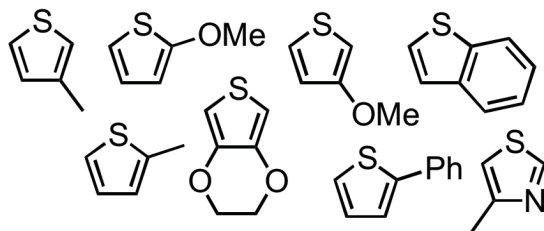

Figure 10. Thiophenes and thiazole to be tested as nucleophiles.

Preliminary studies had shown that thiophene was not a suitable nucleophile to trap the oxyallyl cation, but it is hypothesized that thiophenes bearing electron-donating groups would increase its nucleophilicity and possibly trap the oxyallyl cation. The thiophenes, as well as a thiazole, chosen to begin this study are shown in Figure 10.

3.7 Experimental

3.7.1 General Information

Reactions were carried out using oven-dried Teflon-coated magnetic stir bars in oven-dried glassware (150 °C), sealed with rubber septa under a positive nitrogen atmosphere. Elevated temperatures were maintained using a silicone oil bath controlled with a thermostat device. Temperatures of 0 and -78 °C were achieved using ice/water and ethyl acetate/liquid nitrogen, respectively. Concentration *in vacuo* was achieved using a rotary evaporator (22 mmHg) with residual solvent being removed under high vacuum (5 mmHg).

All reagents were purchased from Sigma-Aldrich, Strem Chemicals, or Alfa Aesar and were used without further purification. Tetrahydrofuran (THF) was distilled over sodium/benzophenone under a dry nitrogen atmosphere. CH₂Cl₂ was distilled over calcium hydride under a dry nitrogen atmosphere. Thin layer chromatography (TLC) was performed using 250 μm aluminum-backed F₂₅₄ silica gel plates from SiliCycle. The plates were visualized by ultraviolet light (254 nm) and treated with *o*-vanillin or potassium permanganate stains followed by heating on a hot plate. Flash chromatography was carried out on 230–400 mesh (40–63 μm) silica gel from SiliCycle.

Melting points (uncorrected) were acquired using a Fisher-Johns apparatus. ¹H and ¹³C NMR spectra were recorded from CDCl₃ solutions on a Bruker Avance 500 spectrometer. Chemical shifts (δ) are reported in parts per million (ppm) downfield from tetramethylsilane but are referenced to the solvent peak (for CDCl₃, ¹H NMR: 7.26 ppm; ¹³C NMR: 77.16 ppm). High-resolution mass spectra (HRMS) were obtained on a Bruker microTOF Focus orthogonal ESI-TOF mass spectrometer. Infrared (IR) spectra were recorded on an FT instrument. Samples were prepared as thin films on a NaCl plate. The X-ray crystal structures were provided by Dr. T. Stanley Cameron.

Structures were determined using ¹H and ¹³C NMR spectra, including two-dimensional NMR experiments (COSY, HSQC and HMBC). Relative stereochemistry was assigned using one-dimensional NOE experiments.^{109,110}

3.7.2 Preparation and Characterization Data

General procedure 1:¹⁰⁰ A solution of α,β -unsaturated ketone (50 mmol) in anhydrous dimethylformamide (DMF) (3.5 mL) and a solution of chlorotrimethylsilane (62 mmol) in DMF (3.5 mL) were both added dropwise over a period of 30 min to a heated (84 °C) solution of triethylamine (62 mmol) in DMF (30 mL). Heating was continued overnight (14 h). The solution was then allowed to attain rt before work-up. The solution was diluted with pentane (50 mL) and washed with cold 5% aqueous NaHCO₃ (150 mL). The aqueous layer was re-extracted with pentane (2 × 50 mL), and the combined organic extracts was washed with distilled water (50 mL), dried over Na₂SO₄ and concentrated *in vacuo*. The residue was then distilled under reduced pressure.

2-(Trimethylsilyloxy)-1,3-butadiene (**100a**)

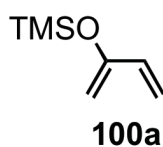

Following *General procedure 1*, 3-buten-2-one (4.1 mL, 50 mmol), chlorotrimethylsilane (7.9 mL, 62 mmol), and triethylamine (8.6 mL, 62 mmol) gave **100a** (2.6 g, 37%) as a colourless liquid. bp 33–35 °C (22 mmHg); ¹H NMR (500 MHz, CDCl₃): δ 6.19 (dd, $J = 16.9, 10.5$ Hz, 1H), 5.47 (dd, $J = 16.9, 1.5$ Hz, 1H), 5.08 (br d, $J = 10.5$ Hz, 1H), 4.35 (s, 1H), 4.34 (s, 1H), 0.23 (s, 9H); ¹³C NMR

(126 MHz, CDCl₃): δ 154.9, 134.6, 114.6, 96.5, 0.7 (3C). These data match those in the literature¹⁰⁰

(E)-2-(Trimethylsilyloxy)-1,3-pentadiene (100b)

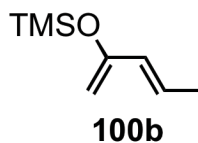

Following *General procedure 1*, 3-penten-2-one (4.9 mL, 50 mmol), chlorotrimethylsilane (7.9 mL, 62 mmol), and triethylamine (8.6 mL, 62 mmol) gave **100b** (3.3 g, 42%) as a colourless liquid. bp 36–37 °C (22 mmHg); ¹H NMR (500 MHz, CDCl₃): δ 5.96 (dq, J = 15.1, 6.4 Hz, 1H), 5.90 (d, J = 15.3 Hz, 1H), 4.20 (s, 2H), 1.76 (d, J = 6.4 Hz, 3H), 0.22 (s, 9H); ¹³C NMR (126 MHz, CDCl₃): δ 155.0, 129.1, 126.7, 93.8, 17.7, 0.2 (3C). These data match those in the literature.¹¹¹

(Z)-3-(Trimethylsilyloxy)-1,3-pentadiene (100c)

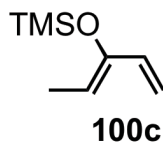

Following *General procedure 1*, 1-penten-3-one (4.9 mL, 50 mmol), chlorotrimethylsilane (7.9 mL, 62 mmol), and triethylamine (8.6 mL, 62 mmol) gave **100c** (1.7 g, 21%) as a colourless liquid. bp 41–42 °C (22 mmHg); ¹H NMR

(500 MHz, CDCl₃): δ 6.17 (dd, $J = 17.1, 10.6$ Hz, 1H), 5.24 (br d, $J = 17.0$ Hz, 1H), 4.93 (br d, $J = 10.1$ Hz, 1H), 4.87 (q, $J = 7.0$ Hz, 1H), 1.64 (d, $J = 7.0$ Hz, 3H), 0.21 (s, 9H); ¹³C NMR (126 MHz, CDCl₃): δ 149.9, 135.6, 111.5, 110.4, 11.7, 0.8 (3C). These data match those in the literature.¹¹²

General Procedure 2:¹⁰¹ A solution of α,β -unsaturated ketone (10 mmol) in THF (40 mL) was cooled to 0 °C. Triethylamine (25 mmol) was added, followed by the slow addition of *tert*-butyldimethylsilyl trifluoromethanesulfonate (11 mmol). The solution was stirred at 0 °C until reaction was complete, as evidenced by TLC. The solution was then diluted with pentane (80 mL), washed with saturated aqueous NaHCO₃ (25 mL), with water (2 \times 25 mL), and with brine (25 mL). The organic layer was dried over MgSO₄, filtered, and concentrated *in vacuo*. The residue was purified by flash chromatography (2% triethylamine in pentane).

(*Z*)-3-(*tert*-Butyldimethylsilyloxy)-1,3-pentadiene (101a)

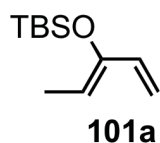

Following *General procedure 2*, 1-penten-3-one (1.0 mL, 10 mmol), *tert*-butyldimethylsilyl trifluoromethanesulfonate (2.5 mL, 11 mmol), and triethylamine (3.5 mL, 25 mmol) were stirred for 1 h at 0 °C to give **101a** (1.16 g, 59%) as a

colourless liquid. ^1H NMR (500 MHz, CDCl_3): δ 6.16 (dd, $J = 17.1, 10.8$ Hz, 1H), 5.27 (d, $J = 17.1$ Hz, 1H), 4.94 (d, $J = 10.8$ Hz, 1H), 4.87 (q, $J = 7.1$ Hz, 1H), 1.64 (d, $J = 7.1$ Hz, 3H), 1.01 (s, 9H), 0.12 (s, 6H); ^{13}C NMR (126 MHz, CDCl_3): δ 149.5, 135.7, 111.8, 110.3, 25.9 (3C), 18.3, 12.0, -2.8, -3.5. These data match those in the literature.¹⁰²

General Procedure 3:¹⁰² A solution of α,β -unsaturated ketone (10 mmol) and *tert*-butyldimethylsilyl trifluoromethanesulfonate (11 mmol) in THF (80 mL) was cooled to -78 °C. A 1 M solution of potassium bis(trimethylsilyl)amide in THF (10 mmol) was slowly added. The solution was stirred at -78 °C for 30 min, then allowed to warm to rt with stirring for 1 h. The mixture was hydrolyzed using saturated aqueous NaHCO_3 (80 mL) and extracted with Et_2O (80 mL). The organic residue was washed with brine (80 mL), dried over MgSO_4 , filtered, and concentrated *in vacuo*. The residue was purified by flash chromatography (2% triethylamine in pentane).

(Z)-3-(tert-Butyldimethylsilyloxy)-1,3-hexadiene (101b)

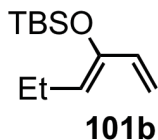

Following *General procedure 3*, 1-hexen-3-one (1.2 mL, 10 mmol), *tert*-butyldimethylsilyl trifluoromethanesulfonate (2.5 mL, 11 mmol), and potassium bis(trimethylsilyl)amide (10 mL, 10 mmol) gave **101b** (1.59 g, 75%) as a colourless liquid. ^1H NMR (500 MHz, CDCl_3): δ 6.14 (dd, $J = 17.2, 10.8$ Hz, 1H), 5.28 (dd, $J = 17.1, 1.0$ Hz, 1H), 4.94 (dd, $J = 10.8, 0.8$ Hz, 1H), 4.76 (t, $J = 7.2$ Hz, 1H), 2.12 (quintet, $J = 7.4$ Hz, 2H), 1.00 (s, 9H), 0.96 (t, $J = 7.5$ Hz, 3H), 0.11 (s, 6H); ^{13}C NMR (126 MHz, CDCl_3): δ 148.0, 135.9, 118.0, 112.0, 26.2 (3C), 19.5, 18.6, 14.2, -3.5 (2C); IR (thin film): ν 1255, 1050, 839, 780 cm^{-1} ; HRMS (APCI) calcd for $[\text{C}_{12}\text{H}_{25}\text{OSi}]^+$: 213.1669, found: 213.1663.

(Z)-3-(tert-Butyldimethylsilyloxy)-5-methyl-1,3-hexadiene (101c)

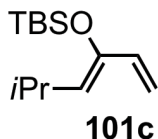

Following *General procedure 3*, 5-methylhex-1-en-3-one¹¹³ (1.12 g, 10 mmol), *tert*-butyldimethylsilyl trifluoromethanesulfonate (2.5 mL, 11 mmol), and potassium bis(trimethylsilyl)amide (10 mL, 10 mmol) gave **101c** (2.08 g, 92%) as a colourless liquid. ^1H NMR (500 MHz, CDCl_3): δ 6.10 (dd, $J = 17.1, 10.8$ Hz, 1H),

5.26 (d, $J = 17.1$ Hz, 1H), 4.93 (d, $J = 10.8$ Hz, 1H), 4.60 (d, $J = 9.7$ Hz, 1H), 2.75-2.65 (m, 1H), 0.98 (s, 9H), 0.94 (d, $J = 7.3$ Hz, 6H), 0.11 (s, 6H); ^{13}C NMR (126 MHz, CDCl_3): δ 146.6, 136.1, 123.5, 112.2, 26.2 (3C), 25.1, 23.1 (2C), 18.6, -3.6 (2C); IR (thin film): ν 1253, 1053, 844 cm^{-1} ; HRMS (ESI) calcd for $[\text{C}_{13}\text{H}_{26}\text{OSiNa}]^+$: 249.1645, found: 249.1653.

2-(*tert*-Butyldimethylsilyloxy)-1-phenyl-1,3-butadiene (**101d**)

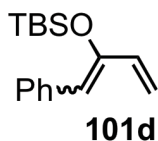

Following *General procedure 3*, 1-phenylbut-3-en-2-one¹⁴ (1.46 g, 10 mmol), *tert*-butyldimethylsilyl trifluoromethanesulfonate (2.5 mL, 11 mmol), and potassium bis(trimethylsilyl)amide (10 mL, 10 mmol) gave a 1:1 mixture of *E*:*Z* isomers of **101d*** (1.30 g, 50%) as a colourless liquid. For *Z*-isomer: ^1H NMR (500 MHz, CDCl_3): δ 7.50 (d, $J = 7.8$ Hz, 2H), 7.26 (t, $J = 7.5$ Hz, 2H), 7.14 (t, $J = 7.4$ Hz, 1H), 6.31 (dd, $J = 17.1, 10.7$ Hz, 1H), 5.78 (s, 1H), 5.48 (d, $J = 17.1$ Hz, 1H), 5.13 (d, $J = 10.7$ Hz, 1H), 0.99 (s, 9H), -0.12 (s, 6H); ^{13}C NMR (126 MHz, CDCl_3): δ 149.8, 136.5, 136.3, 129.3 (2C), 128.0 (2C), 126.4, 114.6, 114.5, 26.1 (3C), 18.5, -3.6 (2C). For *E*-isomer: ^1H NMR (500 MHz, CDCl_3): δ 7.30-7.17 (m, 5H), 6.68 (dd, $J = 16.9, 10.7$ Hz, 1H), 6.01 (s, 1H), 5.67 (d, $J = 16.9$ Hz, 1H), 5.18 (d, $J = 10.7$ Hz, 1H), 1.01 (s, 9H), 0.23 (s, 6H); ^{13}C NMR (126 MHz, CDCl_3): δ 150.1,

* Following *General procedure 2* provides **Z-101d** only, but in 5% yield.

136.6, 131.2, 129.4 (2C), 128.3 (2C), 126.3, 116.5, 113.8, 26.1 (3C), 18.6, – 4.2 (2C). For mixture of isomers: IR (thin film): ν 1630, 1472, 1362, 1254, 1085, 839, 781 cm^{-1} ; HRMS (ESI) calcd for $[\text{C}_{16}\text{H}_{25}\text{OSi}]^+$: 261.1669, found: 261.1680.

2-(*tert*-Butyldimethylsilyloxy)-3-methyl-1,3-butadiene (101e)

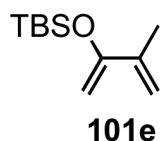

Following *General procedure 2*, 3-methyl-3-buten-2-one (1.0 mL, 10 mmol), *tert*-butyldimethylsilyl trifluoromethanesulfonate (2.5 mL, 11 mmol), and triethylamine (3.5 mL, 25 mmol) were stirred for 1 h at 0 °C to give **101e** (0.34 g, 17%) as a colourless liquid. ^1H NMR (500 MHz, CDCl_3): δ 5.43 (narrow m, 1H), 4.96 (narrow m, 1H), 4.47 (narrow m, 1H), 4.32 (narrow m, 1H), 1.87 (s, 3H), 0.97 (s, 9H), 0.17 (s, 6H); ^{13}C NMR (126 MHz, CDCl_3): δ 156.6, 140.0, 113.8, 92.9, 26.0 (3C), 19.8, 18.4, – 4.6 (2C). These data match those in the literature.¹¹⁵

(E)-2-(tert-Butyldimethylsilyloxy)-1,3-pentadiene (101f)

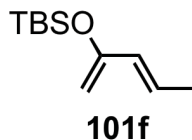

Following *General procedure 2*, 3-penten-2-one (0.98 mL, 10 mmol), *tert*-butyldimethylsilyl trifluoromethanesulfonate (2.5 mL, 11 mmol), and triethylamine (3.5 mL, 25 mmol) were stirred for 1 h at 0 °C to give **101f** (1.50 g, 73%) as a colourless liquid. ¹H NMR (500 MHz, CDCl₃): δ 6.00 (dq, *J* = 15.1, 6.7 Hz, 1H), 5.89 (dq, *J* = 15.1, 1.5 Hz, 1H), 4.19 (s, 1H), 4.18 (s, 1H), 1.77–1.75 (m, 3H), 0.97 (s, 9H), 0.17 (s, 6H); ¹³C NMR (126 MHz, CDCl₃): δ 155.2, 129.3, 126.5, 93.6, 26.0 (3C), 18.4, 17.8, –4.5 (2C). These data match those in the literature.¹⁰¹

2-(tert-Butyldimethylsilyloxy)-4-methyl-1,3-pentadiene (101g)

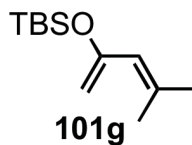

Following *General procedure 2*, 4-methyl-3-penten-2-one (1.1 mL, 10 mmol), *tert*-butyldimethylsilyl trifluoromethanesulfonate (2.5 mL, 11 mmol), and triethylamine (3.5 mL, 25 mmol) were stirred for 1 h at 0 °C to give **101g** (1.95 g, 90%) as a colourless liquid. ¹H NMR (500 MHz, CDCl₃): δ 5.56 (s, 1H), 4.30 (s, 1H), 4.16 (s, 1H), 1.89 (s, 3H), 1.77 (s, 3H), 0.94 (s, 9H), 0.16 (s, 6H); ¹³C NMR

(126 MHz, CDCl₃): δ 155.8, 136.8, 123.3, 95.0, 27.1, 26.0 (3C), 20.0, 18.5, – 4.3 (2C). These data match those in the literature.¹¹⁶

1-(*tert*-Butyldimethylsilyloxy)-1-(1-cyclohexenyl)ethene (101h)

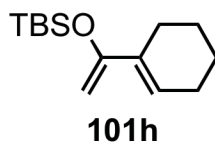

Following *General procedure 2*, 1-acetyl-1-cyclohexene (1.3 mL, 10 mmol), *tert*-butyldimethylsilyl trifluoromethanesulfonate (2.5 mL, 11 mmol), and triethylamine (3.5 mL, 25 mmol) were stirred for 2 h at 0 °C to give **101h** (2.15 g, 90%) as a colourless liquid. ¹H NMR (500 MHz, CDCl₃): δ 6.26–6.24 (narrow m, 1H), 4.34 (s, 1H), 4.18 (s, 1H), 2.14–2.12 (narrow m, 4H), 1.68–1.57 (m, 4H), 0.97 (s, 9H), 0.17 (s, 6H); ¹³C NMR (126 MHz, CDCl₃): δ 156.9, 133.3, 125.5, 89.6, 26.0 (3C), 25.6, 25.1, 22.9, 22.3, 18.5, – 4.5 (2C). These data match those in the literature.¹⁰¹

(2Z,4E)-3-(tert-Butyldimethylsilyloxy)-2,4-hexadiene (101i)

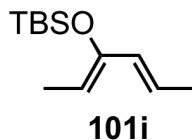

Following *General procedure 3*, 4-hexen-3-one (1.1 mL, 10 mmol), *tert*-butyldimethylsilyl trifluoromethanesulfonate (2.5 mL, 11 mmol), and potassium bis(trimethylsilyl)amide (10 mL, 10 mmol) gave **101i** (1.06 g, 50%) as a colourless liquid. ^1H NMR (500 MHz, CDCl_3): δ 5.85 (br d, $J = 15.4$, 1H), 5.74 (dq, $J = 15.4$, 6.6 Hz, 1H), 4.72 (q, $J = 7.0$ Hz, 1H), 1.73 (d, $J = 6.6$ Hz, 3H), 1.61 (d, $J = 7.0$ Hz, 3H), 1.00 (s, 9H), 0.10 (s, 6H); ^{13}C NMR (126 MHz, CDCl_3): δ 149.2, 130.0, 123.5, 107.1, 26.1 (3C), 18.6, 17.8, 11.8, -3.5 (2C); IR (thin film): ν 1255, 1073, 837 cm^{-1} ; HRMS (ESI) calcd for $[\text{C}_{12}\text{H}_{25}\text{OSi}]^+$: 213.1669, found: 213.1667.

3-Methoxy-4-methyl-1,3-pentadiene (101j)

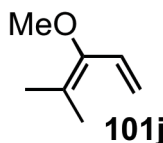

A solution of dimethyl 1-methoxyallylphosphonate (1.7 g, 9.6 mmol) in THF (5.0 mL) was added to a solution of lithium diisopropylamide (11.5 mmol) in THF (20 mL) at -78 $^\circ\text{C}$ and stirred for 30 min. A solution of acetone (0.74 mL, 9.6 mmol) in THF (5.0 mL) was added to the mixture. The mixture was allowed to warm slowly to rt over 1 h. The reaction was quenched by addition of saturated

aqueous NH_4Cl (25 mL), and the mixture was extracted with Et_2O (25 mL). The organic layer was washed with brine (25 mL), dried over MgSO_4 , filtered, and concentrated *in vacuo*. The residue was purified by flash chromatography (10% Et_2O in pentane) to give **101j** (0.30 g, 28%) as a colourless liquid. ^1H NMR (500 MHz, CDCl_3): δ 6.46 (dd, $J = 17.1, 10.8$ Hz, 1H), 5.33 (d, $J = 17.0$ Hz, 1H), 5.04 (dd, $J = 10.8, 0.4$ Hz, 1H), 3.52 (s, 3H), 1.77 (s, 3H), 1.74 (s, 3H); ^{13}C NMR (126 MHz, CDCl_3): δ 149.1, 127.9, 122.0, 112.3, 59.0, 18.5, 18.0. These data match those in the literature.¹⁰³

General procedure 4:⁹⁷ $\text{BF}_3 \cdot \text{OEt}_2$ (0.44 mmol) was added to a solution of the allenyl vinyl ketone⁹³ (0.40 mmol) and the diene (2.0 mmol) in CH_2Cl_2 (40 mL) at -78 °C. The solution was stirred for 5 min then saturated aqueous NaHCO_3 (40 mL) was added at -78 °C. After warming to rt, the aqueous layer was extracted with CH_2Cl_2 (3×40 mL). The combined organic solutions were dried over Na_2SO_4 and concentrated *in vacuo*. The residue was purified by flash chromatography (5% Et_2O in pentane).

(1*R,6*S**,7*S**)-1-Methyl-8-methylene-7-phenyl-4-(trimethylsilyloxy)bicyclo[4.2.1]non-3-en-9-one (102) and (1*R**,6*S**,7*S**)-1-methyl-8-methylene-7-phenylbicyclo[4.2.1]nonane-4,9-dione (103)**

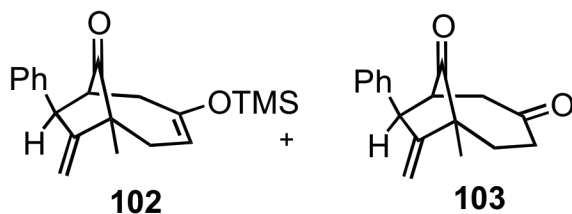

Following *General procedure 4*, **80** (70 mg, 0.40 mmol), **100a** (0.28 g, 2.0 mmol), and $\text{BF}_3 \cdot \text{OEt}_2$ (0.050 mL, 0.44 mmol) gave **102** (35 mg, 27%) and **103** (24 mg, 24%) as colourless oils. For **102**: $^1\text{H NMR}$ (500 MHz, CDCl_3): δ 7.28–7.26 (m, 2H), 7.19 (tt, $J = 7.4, 1.5$ Hz, 1H), 7.04–7.02 (m, 2H), 5.09 (d, $J = 2.4$ Hz, 1H), 4.96 (dt, $J = 7.4, 2.5$ Hz, 1H), 4.86 (d, $J = 2.1$ Hz, 1H), 3.80 (q, $J = 2.1$ Hz, 1H), 2.70–2.68 (m, 1H), 2.57–2.52 (m, 1H), 2.38–2.30 (m, 2H), 2.15 (dd, $J = 15.8, 7.4$ Hz, 1H), 1.30 (s, 3H), 0.19 (s, 9H); $^{13}\text{C NMR}$ (126 MHz, CDCl_3): δ 222.0, 157.7, 149.1, 146.3, 128.9 (2C), 127.5 (2C), 126.6, 110.0, 106.9, 54.7, 53.5, 52.0, 42.6, 37.3, 21.2, 0.5 (3C); IR (thin film): ν 1750 cm^{-1} ; HRMS (ESI) calcd for $[\text{C}_{20}\text{H}_{26}\text{O}_2\text{SiNa}]^+$: 349.1594, found: 349.1581. For **103**: $^1\text{H NMR}$ (500 MHz, CDCl_3): δ 7.29 (t, $J = 7.5$ Hz, 2H), 7.22 (t, $J = 7.4$ Hz, 1H), 7.07 (d, $J = 7.4$ Hz, 2H), 5.25 (d, $J = 1.9$ Hz, 1H), 5.12 (d, $J = 1.7$ Hz, 1H), 3.87 (q, $J = 1.8$ Hz, 1H), 2.86–2.84 (m 1H), 2.78 (dd, $J = 15.1, 5.8$ Hz, 1H), 2.68–2.62 (m, 1H), 2.60–2.52 (m, 2H), 1.95–1.90 (m, 1H), 1.87–1.82 (m, 1H), 1.31 (s, 3H); $^{13}\text{C NMR}$ (126 MHz, CDCl_3): δ 220.2, 209.4, 156.1, 145.0, 129.1 (2C), 127.1 (2C), 127.0, 113.0, 54.0, 53.0, 51.3, 45.5, 41.3, 40.0, 22.3;

IR (thin film): ν 1743, 1704 cm^{-1} ; HRMS (ESI) calcd for $[\text{C}_{17}\text{H}_{18}\text{O}_2\text{Na}]^+$: 277.1199, found: 277.1196.

(1*R,2*R**,6*S**,7*S**)-1,2-Dimethyl-8-methylene-7-phenyl-4-(trimethylsilyloxy)-bicyclo[4.2.1]non-3-en-9-one (104), (1*R**,2*R**,6*S**,7*S**)-1,2-dimethyl-8-methylene-7-phenylbicyclo[4.2.1]nonane-4,9-dione (105), and (4*R**,5*R**)-2,3-dimethyl-5-((*E*)-2-oxopent-3-en-1-yl)-4-phenylcyclopent-2-enone (106)**

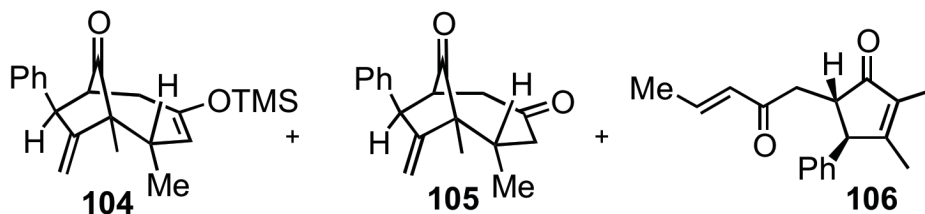

Following *General procedure 4*, **80** (70 mg, 0.40 mmol), **100b** (0.31 g, 2.0 mmol), and $\text{BF}_3 \cdot \text{OEt}_2$ (0.050 mL, 0.44 mmol) gave **104** (11 mg, 8%), **105** (19 mg, 18%) and **106** (24 mg, 22%) as colourless oils. For **104**: ^1H NMR (500 MHz, CDCl_3): δ 7.30–7.27 (m, 2H), 7.23–7.20 (m, 1H), 7.08–7.06 (m, 2H), 5.00 (d, $J = 2.9$ Hz, 1H), 4.79–4.78 (m, 2H), 3.71 (q, $J = 3.2$ Hz, 1H), 2.65 (q, $J = 4.2$ Hz, 1H), 2.62–2.58 (m, 1H), 2.38–2.32 (m, 2H), 1.24 (s, 3H), 1.07 (d, $J = 7.1$ Hz, 3H), 0.19 (s, 9H); ^{13}C NMR (126 MHz, CDCl_3): δ 221.8, 154.2, 147.2, 145.6, 128.9 (2C), 128.2 (2C), 126.7, 115.5, 112.5, 58.4, 53.3, 52.2, 40.8, 37.8, 19.5, 17.7, 0.5 (3C); IR (thin film): ν 1747 cm^{-1} ; HRMS (ESI) calcd for $[\text{C}_{21}\text{H}_{28}\text{O}_2\text{SiNa}]^+$: 363.1751, found: 363.1754. For **105**: ^1H NMR (500 MHz, CDCl_3): δ 7.32–7.28 (m, 2H), 7.25–7.21 (m, 1H), 7.07–7.05 (m, 2H), 5.16 (d, $J = 2.8$ Hz, 1H), 5.05 (d, $J = 2.4$ Hz, 1H),

3.87 (q, $J = 2.7$ Hz, 1H), 2.85-2.78 (m, 2H), 2.61-2.51 (m, 3H), 1.26 (s, 3H), 1.04 (d, $J = 6.8$ Hz, 3H); ^{13}C NMR (126 MHz CDCl_3): δ 220.7, 208.5, 152.8, 146.0, 129.1 (2C), 127.7 (2C), 127.0, 115.4, 58.1, 54.0, 51.5, 50.4, 46.2, 40.7, 19.9, 16.2; IR (thin film): ν 1744, 1712 cm^{-1} ; HRMS (ESI) calcd for $[\text{C}_{18}\text{H}_{20}\text{O}_2\text{Na}]^+$: 291.1356, found: 291.1348. For **106**: ^1H NMR (500 MHz, CDCl_3): δ 7.31 (t, $J = 7.3$ Hz, 2H), 7.24 (t, $J = 7.4$ Hz, 1H), 7.06 (d, $J = 7.6$ Hz, 2H), 6.82 (dq, $J = 15.5, 6.9$ Hz, 1H), 6.08 (d, $J = 15.8$ Hz, 1H), 3.56 (s, 1H), 3.04 (dd, $J = 16.9, 3.7$ Hz, 1H), 2.80 (dd, $J = 16.9, 7.8$ Hz, 1H), 2.58 (t, $J = 3.9$ Hz, 1H), 1.86 (d, $J = 6.8$ Hz, 3H), 1.82 (s, 3H), 1.80 (s, 3H); ^{13}C NMR (126 MHz, CDCl_3): δ 209.3, 198.1, 169.8, 143.3, 141.6, 136.4, 131.6, 129.0 (2C), 127.9 (2C), 127.2, 56.0, 51.9, 40.3, 18.4, 15.6, 8.6; IR (thin film): ν 1700, 1648 cm^{-1} ; HRMS (ESI) calcd for $[\text{C}_{18}\text{H}_{20}\text{O}_2\text{Na}]^+$: 291.1356, found: 291.1352.

(1*R**,5*S**,6*S**,7*S**)-1,5-Dimethyl-8-methylene-7-phenyl-4-(trimethylsilyloxy)-bicyclo[4.2.1]non-3-en-9-one (107a), (1*R**,5*R**,6*S**,7*S**)-1,5-dimethyl-8-methylene-7-phenyl-4-(trimethylsilyloxy)bicyclo[4.2.1]non-3-en-9-one (107b), (1*R**,5*S**,6*S**,7*S**)-1,5-dimethyl-8-methylene-7-phenylbicyclo[4.2.1]nonane-4,9-dione (108a), and (1*R**,5*R**,6*S**,7*S**)-1,5-dimethyl-8-methylene-7-phenylbicyclo[4.2.1]nonane-4,9-dione (108b)

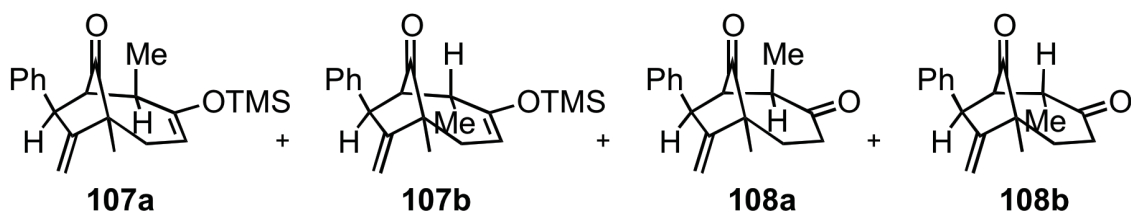

Following *General procedure 4*, **80** (70 mg, 0.40 mmol), **100c** (0.31 g, 2.0 mmol), and $\text{BF}_3 \cdot \text{OEt}_2$ (0.050 mL, 0.44 mmol) gave a 5:1 mixture of **107a** and **107b** (89 mg, 66%) and a 1:1.2 mixture of **108a** and **108b** (31 mg, 29%) as colourless oils. For **107a**: ^1H NMR (500 MHz, CDCl_3): δ 7.30 (t, $J = 7.5$ Hz, 2H), 7.22 (t, $J = 7.3$ Hz, 1H), 7.06 (d, $J = 7.8$ Hz, 2H), 5.13 (d, $J = 2.0$ Hz, 1H), 4.90 (d, $J = 1.2$ Hz, 1H), 4.85 (dd, $J = 7.7, 1.9$ Hz, 1H), 3.80 (s, 1H), 2.54-2.52 (m, 2H), 2.33 (d, $J = 16.0$ Hz, 1H), 2.13 (dd, $J = 15.9, 7.7$ Hz, 1H), 1.32 (s, 3H), 1.20 (d, $J = 6.4$ Hz, 3H), 0.26 (s, 9H); ^{13}C NMR (126 MHz, CDCl_3): δ 219.7, 157.5, 154.2, 146.6, 128.9 (2C), 127.4 (2C), 126.5, 109.8, 104.4, 59.7, 54.2, 53.0, 42.9, 41.6, 21.2, 17.6, 0.7 (3C). For **107b**: ^1H NMR (500 MHz, CDCl_3): δ 7.30 (t, $J = 7.5$ Hz, 2H), 7.22 (t, $J = 7.3$ Hz, 1H), 7.08 (d, $J = 7.8$ Hz, 2H), 5.09 (d, $J = 2.4$ Hz, 1H), 4.98-4.97 (m, 1H), 4.76 (d, $J = 1.7$ Hz, 1H), 3.93 (d, $J = 2.5$ Hz, 1H), 2.72-2.71 (m, 1H), 2.64 (t, $J = 3.3$ Hz, 1H), 2.31-2.28 (m, 1H), 2.20-2.15 (m, 1H), 1.34 (s, 3H), 1.23 (d, $J = 7.2$ Hz, 3H),

0.23 (s, 9H); ^{13}C NMR (126 MHz, CDCl_3): δ 221.4, 158.4, 151.6, 146.5, 128.9 (2C), 128.0 (2C), 126.4, 109.4, 106.2, 60.8, 54.9, 48.6, 42.0, 39.4, 20.1, 17.5, 0.4 (3C). For **107a** and **107b**: IR (thin film): ν 1741 cm^{-1} ; HRMS (ESI) calcd for $[\text{C}_{21}\text{H}_{28}\text{O}_2\text{SiNa}]^+$: 363.1751, found: 363.1747. For **108a**: ^1H NMR (500 MHz, CDCl_3): δ 7.30-7.26 (m, 2H), 7.23-7.18 (m, 1H), 7.07-7.04 (m, 2H), 5.22 (d, $J = 2.2$ Hz, 1H), 5.08 (d, $J = 2.0$ Hz, 1H), 3.96 (q, $J = 2.1$ Hz, 1H), 2.69-2.50 (m, 4H), 1.98-1.80 (m, 2H), 1.27 (s, 3H), 1.25 (d, $J = 7.0$ Hz, 3H); ^{13}C NMR (126 MHz, CDCl_3): δ 218.8, 211.6, 156.2, 145.4, 129.1 (2C), 127.1 (2C), 126.9, 112.5, 58.3, 54.4, 54.2, 50.4, 40.6, 38.8, 22.1, 16.5. For **108b**: ^1H NMR (500 MHz, CDCl_3): δ 7.30-7.26 (m, 2H), 7.23-7.18 (m, 1H), 7.07-7.04 (m, 2H), 5.21 (d, $J = 2.2$ Hz, 1H), 5.00 (d, $J = 1.9$ Hz, 1H), 3.81 (q, $J = 2.1$ Hz, 1H), 2.90 (qd, $J = 6.8, 4.6$ Hz, 1H), 2.69-2.50 (m, 3H), 1.98-1.80 (m, 2H), 1.31 (s, 3H), 1.21 (d, $J = 6.8$ Hz, 3H); ^{13}C NMR (126 MHz, CDCl_3): δ 221.0, 211.2, 156.6, 145.1, 129.0 (2C), 127.3 (2C), 126.8, 112.7, 57.9, 53.2, 47.1, 46.9, 40.7, 40.5, 22.5, 13.9. For **108a** and **108b**: IR (thin film): ν 1743, 1745, 1711, 1709 cm^{-1} ; HRMS (ESI) calcd for $[\text{C}_{18}\text{H}_{20}\text{O}_2\text{Na}]^+$: 291.1356, found: 291.1346.

(1*R**,5*S**,6*S**,7*S**)-4-(*tert*-Butyldimethylsilyloxy)-1,5-dimethyl-8-methylene-7-phenylbicyclo[4.2.1]non-3-en-9-one (**109a**), (1*R**,5*R**,6*S**,7*S**)-4-(*tert*-butyldimethylsilyloxy)-1,5-dimethyl-8-methylene-7-phenylbicyclo[4.2.1]non-3-en-9-one (**109b**), (1*R**,5*S**,6*S**,7*S**)-1,5-dimethyl-8-methylene-7-phenylbicyclo[4.2.1]nonane-4,9-dione (**108a**) and (1*R**,5*R**,6*S**,7*S**)-1,5-dimethyl-8-methylene-7-phenylbicyclo[4.2.1]nonane-4,9-dione (**108b**)

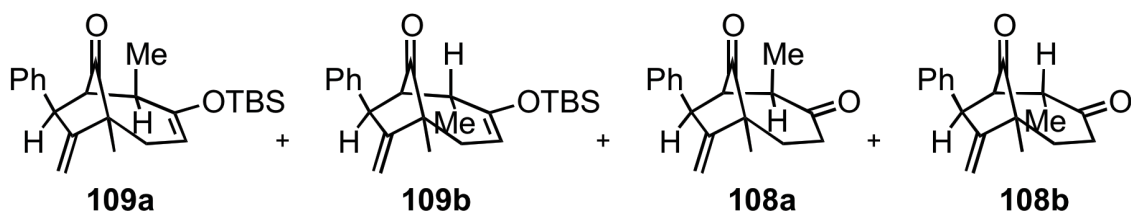

Following *General procedure 4*, **80** (70 mg, 0.40 mmol), **101a** (0.40 g, 2.0 mmol), and $\text{BF}_3 \cdot \text{OEt}_2$ (0.050 mL, 0.44 mmol) gave a 7:1 mixture of **109a** and **109b** (86 mg, 56%) and a 1:1.2 mixture of **108a** and **108b** (46 mg, 43%) as colourless oils. For **109a**: ^1H NMR (500 MHz, CDCl_3): δ 7.28–7.25 (m, 2H), 7.21–7.17 (m, 1H), 7.03–7.02 (m, 2H), 5.09 (d, $J = 2.5$ Hz, 1H), 4.85 (d, $J = 2.1$ Hz, 1H), 4.79 (dd, $J = 7.6, 2.4$ Hz, 1H), 3.75 (t, $J = 2.1$ Hz, 1H), 2.51–2.47 (m, 2H), 2.31–2.27 (m, 1H), 2.09 (dd, $J = 16.0, 7.7$ Hz, 1H), 1.28 (s, 3H), 1.17 (d, $J = 6.8$ Hz, 3H), 0.94 (s, 9H), 0.20 (s, 3H), 0.15 (s, 3H); ^{13}C NMR (126 MHz, CDCl_3): δ 219.9, 157.5, 154.2, 146.5, 128.9 (2C), 127.4 (2C), 126.5, 109.8, 104.2, 59.7, 54.2, 53.0, 42.9, 41.7, 25.8 (3C), 21.2, 18.1, 17.6, – 4.1, – 4.2. For **109b**: ^1H NMR (500 MHz, CDCl_3): δ 7.27–7.24 (m, 2H), 7.19–7.16 (m, 1H), 7.04–7.02 (m, 2H), 5.07 (d, $J = 2.3$ Hz, 1H), 5.05 (dd, $J = 7.2, 2.4$ Hz, 1H), 4.88 (d, $J = 2.0$ Hz, 1H), 3.77 (d, $J = 1.8$ Hz, 1H), 2.64 (dd, $J = 7.8, 3.2$ Hz, 1H), 2.56–2.52 (m, 1H), 2.36–2.32 (m, 1H), 2.28–2.24 (m, 1H),

1.29 (s, 3H), 0.97 (d, $J = 6.9$ Hz, 3H), 0.93 (s, 9H), 0.15 (s, 3H), 0.11 (s, 3H); ^{13}C NMR (126 MHz, CDCl_3): δ 220.3, 162.2, 159.7, 147.6, 128.9 (2C), 127.2 (2C), 126.5, 114.4, 109.7, 56.8, 53.7, 51.9, 46.4, 36.7, 25.9 (3C), 20.2, 18.2, 17.1, - 4.0, - 4.4. For **109a** and **109b**: IR (thin film): ν 1737 cm^{-1} ; HRMS (ESI) calcd for $[\text{C}_{24}\text{H}_{34}\text{O}_2\text{SiNa}]^+$: 405.2220, found: 405.2203.

(1R*,5S*,6S*,7S*)-4-(tert-Butyldimethylsilyloxy)-5-ethyl-1-methyl-8-methylene-7-phenylbicyclo[4.2.1]non-3-en-9-one (110a) and **(1R*,5R*,6S*,7S*)-4-(tert-butyldimethylsilyloxy)-5-ethyl-1-methyl-8-methylene-7-phenylbicyclo[4.2.1]non-3-en-9-one (110b)**

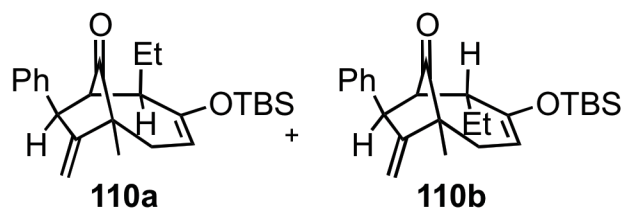

Following *General procedure 4*, **80** (70 mg, 0.40 mmol), **101b** (0.42 g, 2.0 mmol), and $\text{BF}_3 \cdot \text{OEt}_2$ (0.050 mL, 0.44 mmol) gave a 2:1 mixture of **110a** and **110b** (54 mg, 34%) as a colourless oil. For **110a**: ^1H NMR (500 MHz, CDCl_3): δ 7.27 (t, $J = 7.4$ Hz, 2H), 7.19 (t, $J = 7.3$ Hz, 1H), 7.03 (d, $J = 7.3$ Hz, 2H), 5.09 (d, $J = 2.3$ Hz, 1H), 4.86 (d, $J = 2.0$ Hz, 1H), 4.81 (dd, $J = 8.2, 2.3$ Hz, 1H), 3.72 (d, $J = 1.9$ Hz, 1H), 2.69 (dd, $J = 5.3, 1.8$ Hz, 1H), 2.29-2.25 (m, 2H), 2.06 (dd, $J = 15.9, 8.2$ Hz, 1H), 1.64-1.62 (m, 1H), 1.48-1.35 (m, 1H), 1.27 (s, 3H), 0.99 (t, $J = 7.4$ Hz, 3H), 0.95 (s, 9H), 0.22 (s, 3H), 0.17 (s, 3H); ^{13}C NMR (126 MHz, CDCl_3): δ 220.0,

157.5, 154.3, 146.7, 128.9 (2C), 127.4 (2C), 126.5, 109.8, 104.1, 56.2, 54.4, 52.8, 50.3, 41.3, 25.8 (3C), 24.5, 21.0, 18.1, 12.6, - 4.1, - 4.3. For **110b**: ^1H NMR (500 MHz, CDCl_3): δ 7.27 (t, $J = 7.4$ Hz, 2H), 7.19 (t, $J = 7.3$ Hz, 1H), 7.07 (d, $J = 7.3$ Hz, 2H), 5.03 (d, $J = 2.7$ Hz, 1H), 4.92-4.89 (m, 1H), 4.63 (d, $J = 2.3$ Hz, 1H), 3.90 (q, $J = 3.0$ Hz, 1H), 2.81 (t, $J = 3.9$ Hz, 1H), 2.42-2.39 (m, 1H), 2.29-2.25 (m, 1H), 2.19-2.14 (m, 2H), 1.48-1.35 (m, 1H), 1.30 (s, 3H), 0.94 (s, 9H), 0.67 (t, $J = 7.4$ Hz, 3H), 0.15 (s, 3H), 0.12 (s, 3H); ^{13}C NMR (126 MHz, CDCl_3): δ 221.4, 158.8, 151.5, 145.9, 128.8 (2C), 128.1 (2C), 126.4, 108.9, 105.9, 55.9, 55.5, 48.4, 46.8, 41.8, 26.0 (3C), 22.3, 19.9, 18.4, 11.9, - 4.1, - 4.4. For **110a** and **110b**: IR (thin film): ν 1743 cm^{-1} ; HRMS (ESI) calcd for $[\text{C}_{25}\text{H}_{36}\text{O}_2\text{SiNa}]^+$: 419.2377, found: 419.2382.

(1*R,5*R**,6*S**,7*S**)-4-(*tert*-Butyldimethylsilyloxy)-1-methyl-8-methylene-7-phenyl-5-isopropylbicyclo[4.2.1]non-3-en-9-one (111)**

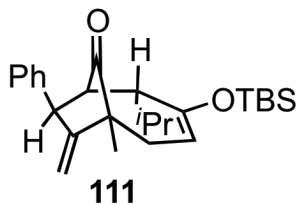

Following *General procedure 4*, **80** (70 mg, 0.40 mmol), **101c** (0.45 g, 2.0 mmol), and $\text{BF}_3 \cdot \text{OEt}_2$ (0.050 mL, 0.44 mmol) gave **111** (62 mg, 38%) as a colourless solid. mp: 168-169 $^\circ\text{C}$; ^1H NMR (500 MHz, CDCl_3): δ 7.25 (t, $J = 7.5$ Hz, 2H), 7.17 (t, $J = 7.4$ Hz, 1H), 6.99 (d, $J = 7.3$ Hz, 2H), 4.99-4.96 (m, 2H), 4.61 (d, $J = 2.2$ Hz, 1H), 3.74 (q, $J = 2.4$ Hz, 1H), 2.74 (br s, 1H), 2.46-2.41 (m, 1H),

2.39 (br s, 1H), 2.15-2.05 (m, 2H), 1.26 (s, 3H), 0.95 (s, 9H), 0.89 (d, $J = 6.8$ Hz, 3H), 0.84 (d, $J = 6.8$ Hz, 3H), 0.21 (s, 3H), 0.15 (s, 3H); ^{13}C NMR (126 MHz, CDCl_3): δ 223.0, 159.1, 153.4, 146.2, 128.7 (2C), 128.2 (2C), 126.3, 109.0, 104.4, 56.1, 54.4, 51.3, 49.7, 41.2, 28.5, 26.1 (3C), 21.9, 19.9, 19.6, 18.4, -4.1, -4.4; IR (thin film): ν 1737 cm^{-1} ; HRMS (ESI) calcd for $[\text{C}_{26}\text{H}_{38}\text{O}_2\text{SiNa}]^+$: 433.2533, found: 433.2533.

(1*R,5*S**,6*S**,7*S**)-4-(*tert*-Butyldimethylsilyloxy)-1-methyl-8-methylene-5,7-diphenylbicyclo[4.2.1]non-3-en-9-one (112a)**, **(1*R**,5*R**,6*S**,7*S**)-4-(*tert*-butyldimethylsilyloxy)-1-methyl-8-methylene-5,7-diphenylbicyclo[4.2.1]non-3-en-9-one (112b)**, and **(1*R**,2*R**,6*S**,7*S**)-3-(*tert*-butyldimethylsilyloxy)-1-methyl-8-methylene-2,7-diphenylbicyclo[4.2.1]non-3-en-9-one (113)**

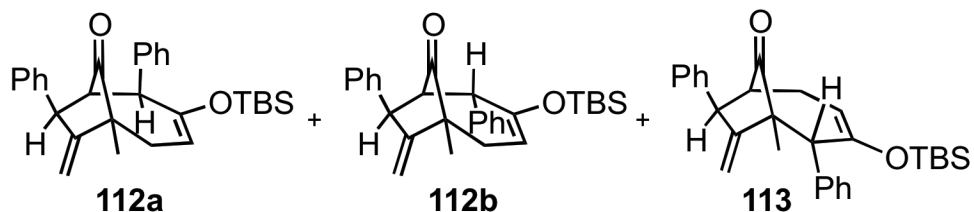

Following *General procedure 4*, **80** (70 mg, 0.40 mmol), **101d** (0.52 g, 2.0 mmol), and $\text{BF}_3 \cdot \text{OEt}_2$ (0.050 mL, 0.44 mmol) gave **112a** (59 mg, 33%) and a 1.3:1 mixture of **112b** and **113** (37 mg, 21%) as colourless oils. For **112a**: ^1H NMR (500 MHz, CDCl_3): δ 7.28-7.17 (m, 6H), 7.05 (d, $J = 7.3$ Hz, 4H), 5.14 (d, $J = 2.3$ Hz, 1H), 5.07 (dd, $J = 7.9, 2.3$ Hz, 1H), 4.92 (d, $J = 2.0$ Hz, 1H), 3.97 (d, $J = 2.0$ Hz, 1H), 3.74 (d, $J = 4.7$ Hz, 1H), 2.75 (dd, $J = 4.8, 2.0$ Hz, 1H), 2.51 (d, $J = 16.1$ Hz,

1H), 2.23 (dd, $J = 16.1, 7.9$ Hz, 1H), 1.28 (s, 3H), 0.75 (s, 9H), 0.13 (s, 3H), -0.11 (s, 3H); ^{13}C NMR (126 MHz, CDCl_3): δ 217.8, 157.2, 151.7, 146.4, 139.3, 128.9 (2C), 128.45 (2C), 128.37 (2C), 127.39 (2C), 127.21, 126.6, 110.2, 106.5, 60.7, 54.8, 54.3, 53.2, 41.7, 25.6 (3C), 21.4, 18.0, -4.1, -4.7; IR (thin film): ν 1744 cm^{-1} ; HRMS (ESI) calcd for $[\text{C}_{29}\text{H}_{36}\text{O}_2\text{SiNa}]^+$: 467.2377, found: 467.2381. For **112b**: ^1H NMR (500 MHz, CDCl_3): δ 7.29-7.02 (m, 8H), 6.52 (d, $J = 6.5$ Hz, 2H), 5.15 (d, $J = 2.4$ Hz, 1H), 5.08-5.07 (m, 1H), 4.82 (d, $J = 2.0$ Hz, 1H), 4.10 (d, $J = 2.4$ Hz, 1H), 3.92-3.91 (m, 1H), 2.78 (dd, $J = 5.0, 3.1$ Hz, 1H), 2.43 (dt, $J = 16.5, 3.3$ Hz, 1H), 2.33 (dd, $J = 17.9, 5.3$ Hz, 1H), 1.35 (s, 3H), 0.58 (s, 9H), 0.05 (s, 3H), -0.10 (s, 3H); ^{13}C NMR (126 MHz, CDCl_3): δ 219.8, 157.5, 148.4, 145.8, 140.0, 129.8 (2C), 128.4 (2C), 128.1 (2C), 127.0, 126.6, 126.0 (2C), 109.8, 108.6, 61.6, 54.6, 50.7, 47.5, 42.8, 25.4 (3C), 21.0, 17.8, -4.1, -5.1. For **113**: ^1H NMR (500 MHz, CDCl_3): δ 7.29-7.02 (m, 10H), 5.02-5.01 (m, 1H), 4.54 (d, $J = 2.5$ Hz, 1H), 4.15 (d, $J = 3.0$ Hz, 1H), 3.92-3.91 (m, 1H), 3.35 (d, $J = 1.8$ Hz, 1H), 2.84 (q, $J = 4.3$ Hz, 1H), 2.71-2.66 (m, 1H), 2.52-2.48 (m, 1H), 1.19 (s, 3H), 0.51 (s, 9H), -0.02 (s, 3H), -0.03 (s, 3H); ^{13}C NMR (126 MHz, CDCl_3): δ 220.3, 153.3, 150.1, 145.1, 137.9, 128.8 (2C), 128.6 (2C), 127.5 (2C), 127.0, 126.7, 126.5 (2C), 114.6, 106.3, 57.7, 56.6, 55.8, 52.4, 32.2, 25.3 (3C), 21.4, 17.8, -4.4, -4.8. For **112b** and **113**: IR (thin film): ν 1745 cm^{-1} ; HRMS (ESI) calcd for $[\text{C}_{29}\text{H}_{37}\text{O}_2\text{Si}]^+$: 445.2557, found: 445.2556.

(1*R**,2*S**,4*S**,5*S**)-2-(1-Methoxy-2-methylprop-1-en-1-yl)-1-methyl-6-methylene-5-phenylbicyclo[2.2.1]heptan-7-one (**114a**), and (1*R**,2*R**,4*S**,5*S**)-2-(1-methoxy-2-methylprop-1-en-1-yl)-1-methyl-6-methylene-5-phenylbicyclo[2.2.1]heptan-7-one (**114b**)

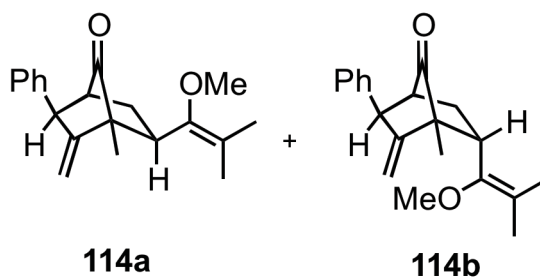

Following *General procedure 4*, **80** (70 mg, 0.40 mmol), **101j** (0.52 g, 2.0 mmol), and $\text{BF}_3 \cdot \text{OEt}_2$ (0.050 mL, 0.44 mmol) gave a 9:1 mixture of **114a** and **114b** (64 mg, 54%) as a colourless oil. For **114a**: ^1H NMR (500 MHz, CDCl_3): δ 7.25 (t, $J = 7.5$ Hz, 2H), 7.18 (t, $J = 7.1$ Hz, 1H), 7.11 (d, $J = 7.8$ Hz, 2H), 5.10 (d, $J = 2.0$ Hz, 1H), 4.81 (s, 1H), 3.78 (s, 1H), 3.55 (s, 3H), 3.04 (dd, $J = 10.3, 5.1$ Hz, 1H), 2.30 (d, $J = 4.7$ Hz, 1H), 2.24 (dt, $J = 12.4, 5.0$ Hz, 1H), 1.96 (dd, $J = 12.2, 10.7$ Hz, 1H), 1.71 (s, 3H), 1.64 (s, 3H), 1.08 (s, 3H); ^{13}C NMR (126 MHz, CDCl_3): δ 214.0, 153.3, 150.7, 143.3, 128.6 (2C), 127.5 (2C), 126.7, 117.0, 107.9, 61.3, 52.9, 51.9, 48.1, 43.4, 28.7, 19.7, 18.7, 9.4. For **114b**: ^1H NMR (500 MHz, CDCl_3): δ 7.26 (t, $J = 7.4$ Hz, 2H), 7.19 (t, $J = 7.3$ Hz, 1H), 7.11 (d, $J = 7.8$ Hz, 2H), 4.95 (d, $J = 2.6$ Hz, 1H), 4.77 (d, $J = 2.1$ Hz, 1H), 3.83 (s, 1H), 3.59 (s, 3H), 3.13 (dd, $J = 10.8, 6.5$ Hz, 1H), 2.17-2.08 (m, 2H), 1.95 (d, $J = 10.4$ Hz, 1H), 1.76 (s, 3H), 1.66 (s, 3H), 1.12 (s, 3H); ^{13}C NMR (126 MHz, CDCl_3): δ 215.1, 150.4, 149.8, 143.9, 128.7 (2C), 127.7 (2C), 126.7, 119.1, 109.6, 61.9, 55.1, 52.9, 48.2, 41.3, 28.1, 20.1, 19.3, 11.4. For

114a and **114b**: IR (thin film): ν 1777, 1767 cm^{-1} ; HRMS (ESI) calcd for $[\text{C}_{20}\text{H}_{24}\text{O}_2\text{Na}]^+$: 319.1669, found: 319.1670.

(1R*,6S*,7S*)-4-(tert-Butyldimethylsilyloxy)-1,3-dimethyl-8-methylene-7-phenylbicyclo[4.2.1]non-3-en-9-one (115)

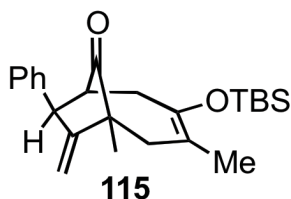

Following *General procedure 4*, **80** (70 mg, 0.40 mmol), **101e** (0.40 g, 2.0 mmol), and $\text{BF}_3 \cdot \text{OEt}_2$ (0.050 mL, 0.44 mmol) gave **115** (54 mg, 35%) as a colourless oil. ^1H NMR (500 MHz, CDCl_3): δ 7.26–7.25 (m, 2H), 7.20–7.17 (m, 1H), 7.03–7.01 (m, 2H), 5.08 (d, $J = 2.4$ Hz, 1H), 4.85 (d, $J = 2.1$ Hz, 1H), 3.80 (q, $J = 2.0$ Hz, 1H), 2.66–2.59 (m, 2H), 2.46 (dd, $J = 16.4, 5.7$ Hz, 1H), 2.40 (br d, $J = 15.6$ Hz, 1H), 2.04 (d, $J = 15.6$ Hz, 1H), 1.64 (br s, 3H), 1.28 (s, 3H), 0.96 (s, 9H), 0.13 (s, 3H), 0.13 (s, 3H); ^{13}C NMR (126 MHz, CDCl_3): δ 222.5, 157.2, 146.3, 142.3, 128.9 (2C), 127.4 (2C), 126.5, 113.9, 109.7, 54.1, 53.8, 51.5, 38.7, 26.1 (3C), 21.0, 20.9, 18.4, – 3.4, – 3.6; IR (thin film): ν 1737 cm^{-1} ; HRMS (ESI) calcd for $[\text{C}_{24}\text{H}_{34}\text{O}_2\text{SiNa}]^+$: 405.2220, found: 405.2229.

(1*R,2*R**,6*S**,7*S**)-4-(*tert*-Butyldimethylsilyloxy)-1,2-dimethyl-8-methylene-7-phenylbicyclo[4.2.1]non-3-en-9-one (116) and (4*R**,5*R**)-2,3-dimethyl-5-((*E*)-2-oxopent-3-en-1-yl)-4-phenylcyclopent-2-enone (106)**

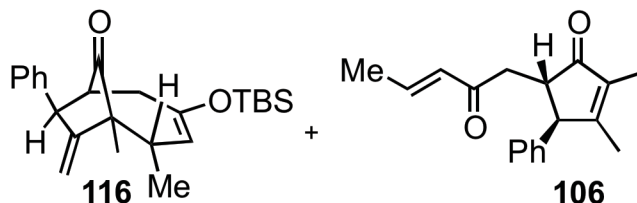

Following *General procedure 4*, **80** (70 mg, 0.40 mmol), **101f** (0.40 g, 2.0 mmol), and $\text{BF}_3 \cdot \text{OEt}_2$ (0.050 mL, 0.44 mmol) were stirred for 5 min at -78°C to give **116** (41 mg, 27%) as a colourless solid, and **106** (37 mg, 35%) as a colourless oil. For **116**: mp: $93\text{--}94^\circ\text{C}$; ^1H NMR (500 MHz, CDCl_3): δ 7.30–7.28 (m, 2H), 7.23–7.20 (m, 1H), 7.09–7.07 (m, 2H), 4.99 (d, $J = 2.9$ Hz, 1H), 4.79 (d, $J = 2.5$ Hz, 1H), 4.78 (t, $J = 2.5$ Hz, 1H), 3.72 (q, $J = 3.2$ Hz, 1H), 2.66 (q, $J = 4.2$ Hz, 1H), 2.63–2.58 (m, 1H), 2.38–2.32 (m, 2H), 1.24 (s, 3H), 1.08 (d, $J = 7.1$ Hz, 3H), 0.92 (s, 9H), 0.15 (s, 3H), 0.12 (s, 3H); ^{13}C NMR (126 MHz, CDCl_3): δ 221.6, 154.2, 147.4, 145.5, 128.8 (2C), 128.2 (2C), 126.6, 115.1, 112.4, 58.4, 53.1, 52.2, 40.9, 37.7, 25.8 (3C), 19.5, 18.1, 17.7, -4.1 , -4.3 ; IR (thin film): ν 1734 cm^{-1} ; HRMS (ESI) calcd for $[\text{C}_{24}\text{H}_{34}\text{O}_2\text{SiNa}]^+$: 405.2220, found: 405.2204.

(1*R,6*S**,7*S**)-4-(*tert*-Butyldimethylsilyloxy)-1,2,2-trimethyl-8-methylene-7-phenylbicyclo[4.2.1]non-3-en-9-one (117)**

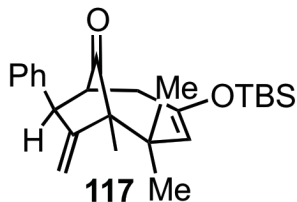

Following *General procedure 4*, **80** (70 mg, 0.40 mmol), **101g** (0.42 g, 2.0 mmol), and $\text{BF}_3 \cdot \text{OEt}_2$ (0.050 mL, 0.44 mmol) gave **117** (63 mg, 40%) as a colourless oil. ^1H NMR (500 MHz, CDCl_3): δ 7.27 (t, $J = 7.5$ Hz, 2H), 7.19 (t, $J = 7.3$ Hz, 1H), 7.06 (d, $J = 7.8$ Hz, 2H), 5.04 (d, $J = 2.7$ Hz, 1H), 4.85–4.82 (m, 2H), 3.75 (q, $J = 2.6$ Hz, 1H), 2.62–2.57 (m, 2H), 2.35 (dd, $J = 17.8, 6.2$ Hz, 1H), 1.22 (s, 3H), 1.12 (s, 3H), 1.01 (s, 3H), 0.93 (s, 9H), 0.16 (s, 3H), 0.12 (s, 3H); ^{13}C NMR (126 MHz, CDCl_3): δ 220.9, 157.0, 146.6, 146.3, 128.8 (2C), 128.1 (2C), 126.5, 121.8, 113.3, 60.0, 53.6, 51.8, 40.6, 37.5, 26.3, 26.0, 25.9 (3C), 18.2, 17.1, – 3.9, – 4.3; IR (thin film): ν 1740 cm^{-1} ; HRMS (ESI) calcd for $[\text{C}_{25}\text{H}_{36}\text{O}_2\text{SiNa}]^+$: 419.2377, found: 419.2369.

(1*R**,2*R**,10*S**,11*S**)-8-(*tert*-Butyldimethylsilyloxy)-1-methyl-12-methylene-11-phenyltricyclo[8^{2,7}.2.1]tridec-7-en-13-one (**118**) and (4*R**,5*R**)-2,3-dimethyl-5-(1-(cyclohex-1-enyl)-1-oxoethan-2-yl)-4-phenylcyclopent-2-enone (**119**)

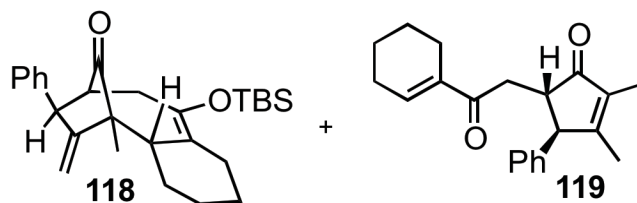

Following *General procedure 4*, **80** (70 mg, 0.40 mmol), **101h** (0.48 g, 2.0 mmol), and $\text{BF}_3 \cdot \text{OEt}_2$ (0.050 mL, 0.44 mmol) gave **118** (69 mg, 41%) as a colourless oil. ¹H NMR (500 MHz, CDCl_3): δ 7.26–7.25 (m, 2H), 7.19–7.17 (m, 1H), 7.05–7.02 (m, 2H), 5.07 (d, $J = 2.2$ Hz, 1H), 4.90 (d, $J = 2.0$ Hz, 1H), 3.80 (q, $J = 1.7$ Hz, 1H), 3.09–3.06 (m, 1H), 2.67–2.62 (m, 2H), 2.49–2.45 (m, 1H), 2.08–2.05 (m, 2H), 1.84 (br d, $J = 12.6$ Hz, 1H), 1.73 (br d, $J = 12.6$ Hz, 1H), 1.42–1.38 (m, 2H), 1.27 (s, 3H), 1.26–1.22 (m, 1H), 1.07–0.99 (m, 1H), 0.95 (s, 9H), 0.15 (s, 3H), 0.15 (s, 3H); ¹³C NMR (126 MHz, CDCl_3): δ 220.9, 159.9, 146.5, 138.1, 128.9 (2C), 127.1 (2C), 126.5, 123.6, 109.5, 58.4, 55.4, 53.5, 52.3, 38.4, 32.6, 30.8, 28.8, 27.7, 26.1 (3C), 20.8, 18.5, – 3.4, – 3.5; IR (thin film): ν 1729 cm^{-1} ; HRMS (ESI) calcd for $[\text{C}_{27}\text{H}_{39}\text{O}_2\text{Si}]^+$: 423.2714, found: 423.2699.

* Small signals at δ 3.56 and 2.58 ppm in the ¹H NMR spectrum of the crude mixture indicated a trace amount of **27**.

(1*R,2*S**,5*S**,6*S**,7*S**)-4-(*tert*-Butyldimethylsilyloxy)-1,2,5-trimethyl-8-methylene-7-phenylbicyclo[4.2.1]non-3-en-9-one (120) and (1*R**,2*R**,5*R**,6*S**,7*S**)-4-(*tert*-butyldimethylsilyloxy)-1,2,5-trimethyl-8-methylene-7-phenylbicyclo[4.2.1]non-3-en-9-one (121)**

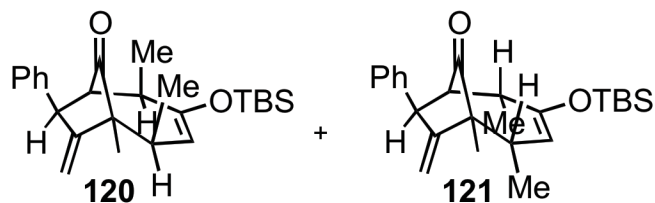

Following *General procedure 4*, **80** (70 mg, 0.40 mmol), **101i** (0.42 g, 2.0 mmol), and $\text{BF}_3 \cdot \text{OEt}_2$ (0.050 mL, 0.44 mmol) gave a mixture of **120** (35 mg, 22%) and **121** (32 mg, 20%) as colourless oils. For **120**: ^1H NMR (500 MHz, CDCl_3): δ 7.26 (t, $J = 7.5$ Hz, 2H), 7.18 (t, $J = 7.3$ Hz, 1H), 7.02 (d, $J = 7.7$ Hz, 2H), 5.06 (d, $J = 1.5$ Hz, 1H), 4.89 (d, $J = 7.2$ Hz, 1H), 4.86 (s, 1H), 3.73 (s, 1H), 2.46-2.44 (m, 2H), 2.22 (quintet, $J = 7.0$ Hz, 1H), 1.29 (s, 3H), 1.16 (d, $J = 6.6$ Hz, 3H), 0.98 (d, $J = 6.9$ Hz, 3H), 0.95 (s, 9H), 0.21 (s, 3H), 0.16 (s, 3H); ^{13}C NMR (126 MHz, CDCl_3): δ 218.5, 159.6, 152.5, 146.9, 128.9 (2C), 127.2 (2C), 126.4, 112.1, 109.5, 59.9, 56.5, 53.0, 46.1, 42.9, 25.9 (3C), 20.3, 18.4, 18.2, 17.8, -3.9, -4.2. For **121**: ^1H NMR (500 MHz, CDCl_3): δ 7.28 (t, $J = 7.5$ Hz, 2H), 7.20 (t, $J = 7.0$ Hz, 1H), 7.10 (d, $J = 7.8$ Hz, 2H), 4.93 (d, $J = 2.7$ Hz, 1H), 4.73 (s, 1H), 4.63 (d, $J = 1.8$ Hz, 1H), 3.78 (t, $J = 2.2$ Hz, 1H), 2.76-2.74 (m, 1H), 2.64 (t, $J = 4.6$ Hz, 1H), 2.30-2.26 (m, 1H), 1.23 (s, 3H), 1.12 (d, $J = 7.1$ Hz, 3H), 1.04 (d, $J = 6.8$ Hz, 3H), 0.93 (s, 9H), 0.14 (s, 3H), 0.11 (s, 3H); ^{13}C NMR (126 MHz, CDCl_3): δ 220.4, 154.8, 150.0, 145.5, 128.8 (2C), 128.7 (2C), 126.5, 113.9, 111.6, 59.7, 58.4, 49.0, 40.6, 40.2, 26.0

(3C), 18.7, 18.3, 18.0, 17.1, - 4.1, - 4.4. For **120** and **121**: IR (thin film): ν 1740 cm^{-1} ; HRMS (ESI) calcd for $[\text{C}_{25}\text{H}_{36}\text{O}_2\text{SiNa}]^+$: 419.2377, found: 419.2362.

(1R*,5R*,6S*,8R*)-4-(tert-Butyldimethylsilyloxy)-1,5-dimethyl-7-methylene-8-phenylbicyclo[4.2.1]non-3-en-9-one (122a), and **(1R*,5S*,6S*,8R*)-4-(tert-butylidimethylsilyloxy)-1,5-dimethyl-7-methylene-8-phenylbicyclo[4.2.1]non-3-en-9-one (122b)**

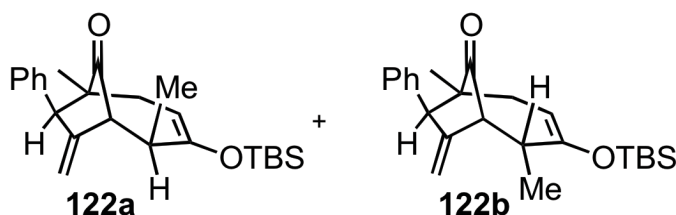

Following *General procedure 4*, **93** (70 mg, 0.40 mmol), **101a** (0.40 g, 2.0 mmol), and $\text{BF}_3 \cdot \text{OEt}_2$ (0.050 mL, 0.44 mmol) gave a 2.7:1 mixture of **122a** and **122b** (34 mg, 22%) as a colourless oil. For **122a**: ^1H NMR (500 MHz, CDCl_3): δ 7.26-7.22 (m, 2H), 7.18-7.15 (m, 1H), 6.96-6.93 (m, 2H), 5.16 (s, 1H), 4.93 (s, 1H), 4.80 (dd, $J = 5.7, 4.6$ Hz, 1H), 3.78 (s, 1H), 3.05 (dd, $J = 5.7, 1.0$ Hz, 1H), 2.47 (quintet, $J = 6.7$ Hz, 1H), 2.24-2.19 (m, 2H), 1.24 (d, $J = 7.1$ Hz, 3H), 0.92 (s, 9H), 0.66 (s, 3H), 0.14 (s, 6H); ^{13}C NMR (126 MHz, CDCl_3): δ 219.8, 155.3, 152.2, 144.5, 128.9, 128.4 (2C), 126.5 (2C), 111.6, 102.9, 57.9, 56.8, 54.4, 44.9, 41.5, 26.0 (3C), 20.4, 18.1, 16.7, - 4.1, - 4.2. For **122b**: ^1H NMR (500 MHz, CDCl_3): δ 7.26-7.22 (m, 2H), 7.18-7.15 (m, 1H), 6.96-6.93 (m, 2H), 5.18 (s, 1H), 4.91-4.90 (m, 2H), 3.72 (s, 1H), 3.08 (s, 1H), 2.71-2.69 (m, 1H), 2.24-2.19 (m, 1H), 2.15-2.11 (m,

1H), 1.33 (d, $J = 7.3$ Hz, 3H), 0.93 (s, 9H), 0.67 (s, 3H), 0.16 (s, 3H), 0.15 (s, 3H); ^{13}C NMR (126 MHz, CDCl_3): δ 222.2, 154.2, 149.6, 144.3, 129.4, 129.0 (2C), 128.3 (2C), 113.6, 102.7, 59.2, 58.1, 54.6, 41.4, 40.4, 25.8 (3C), 19.9, 18.4, 17.9, - 4.2 (2C). For **122a** and **122b**: IR (thin film): ν 1742 cm^{-1} ; HRMS (ESI) calcd for $[\text{C}_{24}\text{H}_{34}\text{O}_2\text{SiNa}]^+$: 405.2220, found: 405.2217.

(1*R,6*S**,8*R**)-4-(*tert*-Butyldimethylsilyloxy)-1,5,5-trimethyl-7-methylene-8-phenylbicyclo[4.2.1]non-3-en-9-one (123)**

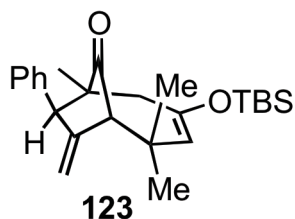

Following *General procedure 4*, **93** (70 mg, 0.40 mmol), **101g** (0.40 g, 2.0 mmol), and $\text{BF}_3 \cdot \text{OEt}_2$ (0.050 mL, 0.44 mmol) gave **123** (43 mg, 27%) as a colourless oil. ^1H NMR (500 MHz, CDCl_3): δ 7.25 (t, $J = 7.4$ Hz, 2H), 7.20 (t, $J = 7.2$ Hz, 1H), 7.03 (d, $J = 7.3$ Hz, 2H), 5.15 (d, $J = 2.5$ Hz, 1H), 4.90 (s, 1H), 4.83 (d, $J = 1.9$ Hz, 1H), 3.95 (d, $J = 1.7$ Hz, 1H), 2.81 (s, 1H), 2.31 (dd, $J = 16.8, 2.3$ Hz, 1H), 2.17 (d, $J = 16.8$ Hz, 1H), 1.25 (s, 3H), 1.17 (s, 3H), 0.94 (s, 9H), 0.63 (s, 3H), 0.17 (s, 3H), 0.12 (s, 3H); ^{13}C NMR (126 MHz, CDCl_3): δ 219.3, 149.5, 146.7, 143.1, 130.1, 128.2 (2C), 126.7 (2C), 118.8, 114.4, 65.9, 57.2, 51.1, 47.7, 38.9, 30.6, 29.2, 25.9 (3C), 21.0, 18.2, - 4.0, - 4.3; IR (thin film): ν 1742 cm^{-1} ; HRMS (ESI) calcd for $[\text{C}_{25}\text{H}_{36}\text{O}_2\text{SiNa}]^+$: 419.2377, found: 419.2371.

(4a*R,8*R**,9*R**,10a*R**)-8-Methyl-10-methyleneoctahydro-1*H*-4a,9-methano-benzo[8]annulene-7,11(2*H*)-dione (124)**

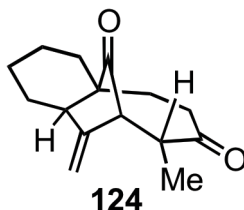

Following *General procedure 4*, **95** (70 mg, 0.40 mmol), **101a** (0.40 g, 2.0 mmol), and $\text{BF}_3 \cdot \text{OEt}_2$ (0.050 mL, 0.44 mmol) gave **124** (3 mg, 3%) as a colourless oil. ^1H NMR (500 MHz, CDCl_3): δ 5.21-5.20 (m, 1H), 5.14-5.13 (m, 1H), 3.00-2.98 (m, 1H), 2.88-2.82 (m, 1H), 2.76-2.71 (m, 1H), 2.55-2.51 (m, 1H), 2.32-2.27 (m, 1H), 2.21-2.17 (m, 1H), 1.92-1.88 (m, 1H), 1.75-1.70 (m, 1H), 1.65-1.57 (m, 3H), 1.33 (d, $J = 7.4$ Hz, 3H), 1.20-1.10 (m, 3H), 0.97-0.87 (m, 1H); ^{13}C NMR (126 MHz, CDCl_3): δ 219.1, 212.3, 149.8, 110.7, 53.5, 51.3, 49.7, 47.5, 39.6, 38.9, 34.7, 30.6, 24.4, 23.0, 16.3. HRMS pending.

General procedure 5: $\text{BF}_3 \cdot \text{OEt}_2$ (1.1 equiv) was added to a solution of a Nazarov product in CH_2Cl_2 (0.1 M) at rt. The solution was stirred for 5 min before saturated aqueous NaHCO_3 (40 mL) was added. The aqueous layer was extracted with CH_2Cl_2 (3×40 mL). The combined organic solutions were dried over Na_2SO_4 and concentrated *in vacuo*. The residue was purified by flash chromatography (15% Et_2O in pentane).

(4*R,5*R**)-2,3-Dimethyl-5-((*E*)-2-oxopent-3-en-1-yl)-4-phenylcyclopent-2-enone (106)**

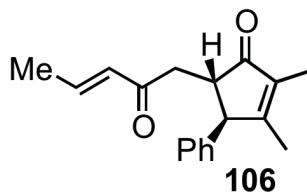

Following *General procedure 5*, **116** (41 mg, 0.11 mmol) and $\text{BF}_3 \cdot \text{OEt}_2$ (0.010 mL, 0.12 mmol) gave **106** (29 mg, 90%) as a colourless oil.

(1*R,5*S**,6*S**,7*S**)-1,5-Dimethyl-8-methylene-7-phenyl-bicyclo[4.2.1]nonane-4,9-dione (108a) and (1*R**,5*R**,6*S**,7*S**)-1,5-dimethyl-8-methylene-7-phenylbicyclo[4.2.1]nonane-4,9-dione (108b)**

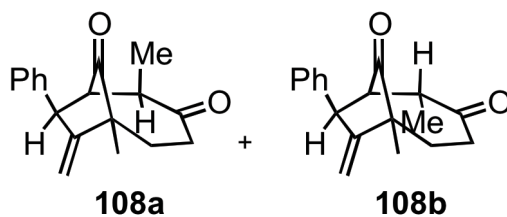

Following *General procedure 5*, a 7:1 mixture of **109a** and **109b** (86 mg, 0.22 mmol) and $\text{BF}_3 \cdot \text{OEt}_2$ (0.030 mL, 0.25 mmol) gave a 7:1 mixture of **108a** and **108b** (57 mg, 95%) as a colourless oil.

(1*R,5*R**,6*S**,7*S**)-1-Methyl-8-methylene-7-phenyl-5-isopropylbicyclo[4.2.1]-nonane-4,9-dione (125)**

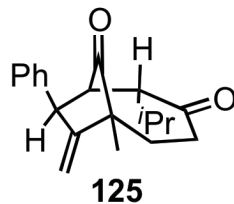

Following *General procedure 5*, **111** (62 mg, 0.40 mmol) and $\text{BF}_3 \cdot \text{OEt}_2$ (0.050 mL, 0.44 mmol) gave **125** (42 mg, 94%) as a colourless oil. ^1H NMR (500 MHz, CDCl_3): δ 7.29-7.26 (m, 2H), 7.20 (t, $J = 7.4$ Hz, 1H), 7.03 (d, $J = 7.2$ Hz, 2H), 5.16 (d, $J = 2.1$ Hz, 1H), 4.95 (d, $J = 1.8$ Hz, 1H), 3.88 (d, $J = 2.0$ Hz, 1H), 2.88 (dd, $J = 5.1, 2.4$ Hz, 1H), 2.57-2.53 (m, 1H), 2.47-2.41 (m, 2H), 2.25-2.22 (m, 1H), 1.94-1.87 (m, 2H), 1.30 (s, 3H), 0.91 (d, $J = 6.5$ Hz, 3H), 0.77 (d, $J = 6.7$ Hz, 3H); ^{13}C NMR (126 MHz, CDCl_3): δ 221.7, 210.8, 157.6, 146.0, 129.1 (2C), 127.3 (2C), 126.8, 112.4, 59.8, 54.4, 53.8, 47.2, 41.3, 40.5, 26.1, 22.3, 21.9, 20.4; IR (thin film): ν 1742, 1708 cm^{-1} ; HRMS (ESI) calcd for $[\text{C}_{20}\text{H}_{24}\text{O}_2\text{Na}]^+$: 319.1669, found: 319.1667.

(1*R**,2*S**,5*S**,6*S**,7*S**)-1,2,5-Trimethyl-8-methylene-7-phenylbicyclo[4.2.1]-nonane-4,9-dione (**126**), (4*R**,5*R**)-2,3-dimethyl-5-((*R**,*E*)-3-oxohex-4-en-2-yl)-4-phenylcyclopent-2-enone (**127**), and (1*R**,2*R**,5*S**,10*R**)-2,5,8-trimethyl-10-phenylbicyclo[5.2.1]dec-7-ene-3,9-dione (**128**)

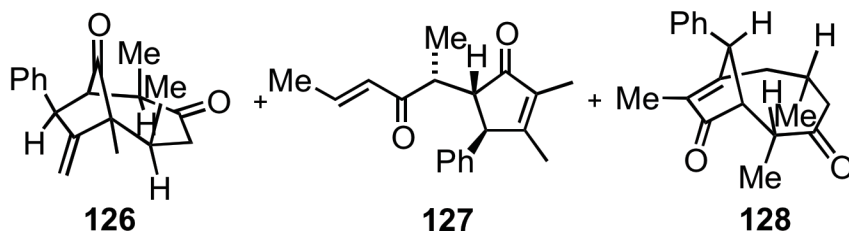

Following *General procedure 5*, **120** (35 mg, 0.40 mmol) and $\text{BF}_3 \cdot \text{OEt}_2$ (0.050 mL, 0.44 mmol) gave **126** (4 mg, 15%), **127** (11 mg, 46%), and **128** (9 mg, 38%) as colourless oils. For **126**: ^1H NMR (500 MHz, CDCl_3): δ 7.31 (t, $J = 7.6$ Hz, 2H), 7.24 (t, $J = 7.2$ Hz, 1H), 7.09 (d, $J = 7.7$ Hz, 2H), 5.24 (s, 1H), 5.10 (s, 1H), 4.00 (s, 1H), 3.00-2.97 (m, 1H), 2.63-2.62 (m, 2H), 2.43-2.39 (m, 1H), 2.00-1.97 (m, 1H), 1.28 (s, 3H), 1.26 (s, 3H), 0.96 (d, $J = 7.0$ Hz, 3H); ^{13}C NMR discernable signals (126 MHz, CDCl_3): δ 146.0, 129.1 (2C), 127.1 (2C), 126.9, 112.2, 58.7, 57.3, 54.8, 50.4, 44.3, 20.4, 16.5; IR (thin film): ν 1737, 1704 cm^{-1} ; HRMS (ESI) calcd for $[\text{C}_{19}\text{H}_{22}\text{O}_2\text{Na}]^+$: 305.1512, found: 305.1506. For **127**: ^1H NMR (500 MHz, CDCl_3): δ 7.26-7.24 (m, 2H), 7.20-7.17 (m, 1H), 6.99 (d, $J = 7.8$ Hz, 2H), 6.73 (dq, $J = 14.9, 7.3$ Hz, 1H), 6.01 (d, $J = 15.6$ Hz, 1H), 3.57 (s, 1H), 3.38-3.33 (m, 1H), 2.67 (s, 1H), 1.80 (s, 3H), 1.79 (s, 3H), 1.70 (d, $J = 6.9$ Hz, 3H), 0.96 (d, $J = 6.8$ Hz, 3H); ^{13}C NMR (126 MHz, CDCl_3): δ 208.9, 201.4, 171.5, 142.9, 141.4, 137.2, 130.0, 128.8 (2C), 128.0 (2C), 127.0, 56.6, 51.5, 44.0, 18.2, 15.6, 10.8, 8.4; IR (thin film): ν 1702, 1649 cm^{-1} ; HRMS (ESI) calcd for $[\text{C}_{19}\text{H}_{22}\text{O}_2\text{Na}]^+$: 305.1512, found:

305.1513. For **128**: ^1H NMR (500 MHz, CDCl_3): δ 7.30 (t, $J = 7.5$ Hz, 2H), 7.24 (t, $J = 6.9$ Hz, 1H), 7.14 (d, $J = 7.7$ Hz, 2H), 4.31 (s, 1H), 3.27 (dd, $J = 6.6, 3.9$ Hz, 1H), 3.01 (dd, $J = 14.0, 3.3$ Hz, 1H), 2.85 (d, $J = 3.7$ Hz, 1H), 2.74 (dt, $J = 7.0, 3.6$ Hz, 1H), 2.64-2.60 (m, 1H), 2.52 (dd, $J = 12.5, 3.8$ Hz, 1H), 2.17 (dd, $J = 14.0, 7.1$ Hz, 1H), 1.68 (s, 3H), 1.28 (d, $J = 7.0$ Hz, 3H), 1.12 (d, $J = 6.8$ Hz, 3H); ^{13}C NMR (126 MHz, CDCl_3): δ 211.1, 208.4, 173.5, 141.0, 135.2, 129.1 (2C), 127.5, 127.2 (2C), 65.4, 58.5, 53.3, 48.2, 35.3, 34.2, 22.7, 14.6, 9.4; IR (thin film): ν 1703, 1641 cm^{-1} ; HRMS (ESI) calcd for $[\text{C}_{19}\text{H}_{22}\text{O}_2\text{Na}]^+$: 305.1512, found: 305.1499.

(1R*,2R*,5R*,6S*,7S*)-1,2,5-Trimethyl-8-methylene-7-phenylbicyclo[4.2.1]-nonane-4,9-dione (129), **(4R*,5R*)-2,3-dimethyl-5-((S*,E)-3-oxohex-4-en-2-yl)-4-phenylcyclopent-2-enone (130)**, and **(1R*,2S*,5S*,10R*)-2,5,8-trimethyl-10-phenylbicyclo[5.2.1]dec-7-ene-3,9-dione (131)**

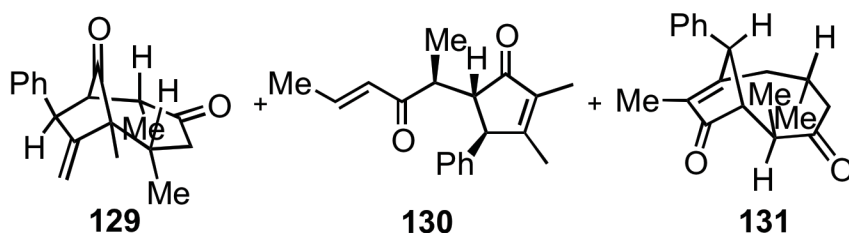

Following *General procedure 5*, **121** (32 mg, 0.40 mmol) and $\text{BF}_3 \cdot \text{OEt}_2$ (0.050 mL, 0.44 mmol) gave **129** (1 mg, 5%), **130** (16 mg, 70%), and **131** (3 mg, 15%) as colourless oils. For **129**: ^1H NMR (500 MHz, CDCl_3): δ 7.28 (t, $J = 7.1$ Hz, 2H), 7.20 (t, $J = 7.4$ Hz, 1H), 7.04 (d, $J = 7.5$ Hz, 2H), 5.10 (s, 1H), 4.93 (s, 1H), 3.71-3.70 (m, 1H), 2.95-2.93 (m, 1H), 2.65-2.59 (m, 2H), 2.39-2.36 (m, 1H), 2.04-

2.00 (m, 1H), 1.29 (s, 3H), 1.17 (d, $J = 6.9$ Hz, 3H), 1.02 (d, $J = 6.9$ Hz, 3H); ^{13}C NMR (126 MHz, CDCl_3): δ 220.7, 210.7, 153.1, 146.3, 129.0 (2C), 128.0 (2C), 126.8, 115.2, 57.9, 57.6, 48.5, 48.1, 47.8, 40.3, 20.7, 16.6, 14.4; IR (thin film): ν 1740, 1708 cm^{-1} ; HRMS (ESI) calcd for $[\text{C}_{19}\text{H}_{22}\text{O}_2\text{Na}]^+$: 305.1512, found: 305.1500. For **130**: ^1H NMR (500 MHz, CDCl_3): δ 7.30 (t, $J = 7.3$ Hz, 2H), 7.23 (t, $J = 7.0$ Hz, 1H), 7.09 (d, $J = 7.6$ Hz, 2H), 6.85 (dq, $J = 14.8, 7.3$ Hz, 1H), 6.11 (d, $J = 15.5$ Hz, 1H), 3.86 (s, 1H), 2.51-2.41 (m, 2H), 1.85 (d, $J = 6.9$ Hz, 3H), 1.75 (s, 6H), 1.17 (d, $J = 7.2$ Hz, 3H); ^{13}C NMR (126 MHz, CDCl_3): δ 209.3, 201.5, 170.7, 143.5, 142.4, 136.4, 130.5, 129.0 (2C), 127.9 (2C), 127.1, 58.4, 53.0, 44.5, 18.4, 15.6, 15.5, 8.4; IR (thin film): ν 1710, 1650 cm^{-1} ; HRMS (ESI) calcd for $[\text{C}_{19}\text{H}_{22}\text{O}_2\text{Na}]^+$: 305.1512, found: 305.1507. For **131**: ^1H NMR (500 MHz, CDCl_3): δ 7.28 (d, $J = 7.9$ Hz, 2H), 7.22 (t, $J = 7.2$ Hz, 1H), 7.08 (d, $J = 7.5$ Hz, 2H), 3.96 (s, 1H), 2.87-2.83 (m, 1H), 2.68-2.59 (m, 4H), 2.42 (dd, $J = 11.8, 4.4$ Hz, 1H), 2.06-2.02 (m, 1H), 1.79 (s, 3H), 1.31 (d, $J = 7.0$ Hz, 3H), 1.23 (d, $J = 6.4$ Hz, 3H); ^{13}C NMR (126 MHz, CDCl_3): δ 213.1, 210.2, 175.8, 141.0, 135.7, 129.1 (2C), 127.4, 127.2 (2C), 64.6, 54.1, 53.5, 45.7, 35.9, 35.0, 23.7, 17.5, 9.4; IR (thin film): ν 1705, 1640 cm^{-1} ; HRMS (ESI) calcd for $[\text{C}_{19}\text{H}_{22}\text{O}_2\text{Na}]^+$: 305.1512, found: 305.1498.

Chapter 4 – The Study of Cyclohexyne

4.1 Introduction

Angle-strained cycloalkynes have been studied for quite some time, yet their use in organic synthesis has been limited.¹¹⁷ Cyclooctyne is the smallest isolable unsubstituted cycloalkyne, whereas cycloheptyne, cyclohexyne (**144**) and cyclopentyne can only be prepared *in situ* and reacted immediately with nucleophiles. Cyclohexyne is of particular interest because its aromatic analog, benzyne, has been studied and used extensively in synthesis, whereas cyclohexyne has been used very little.⁷

Experiments by Wittig and Harboth involving elimination-addition reactions of 1-chlorocyclohexene (**145**) with phenyllithium were described as proceeding via a putative cyclohexyne intermediate (Scheme 45).¹¹⁸ This hypothesis was later corroborated by experiments using ¹⁴C-labeled precursors of **145**, providing strong evidence for a cyclohexyne intermediate.¹¹⁹ This method of forming cyclohexyne by the β -elimination of a halogen has since been used to form 1-aminated,¹²⁰⁻¹²² and 1-propargyl cyclohexene derivatives.¹²³ This method often yields multiple byproducts, presumed to be due to an isomerization of **144** to the cycloallene.¹²⁴

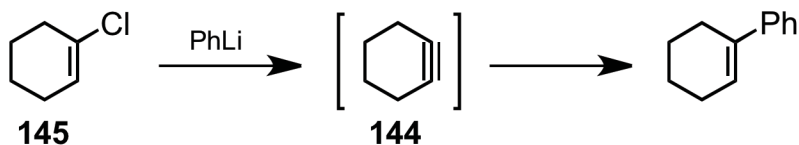

Scheme 45. Putative formation of 144 in the elimination-addition reaction of 145.

It was later shown by Caubere and coworkers that base-mediated elimination of 1-chloro-substituted cyclohexene derivatives could also undergo (2+2) additions with enolates (Scheme 46).¹²⁴ Depending on which cyclohexene and enolate precursors were used, mixtures of the (2+2) adduct **146** and a ring expanded product **147** were formed in different proportions.

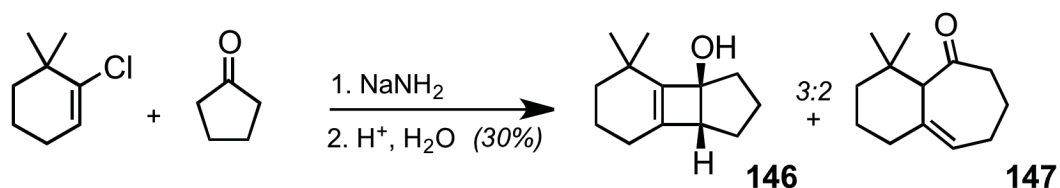

Scheme 46. The (2+2) addition of an enolate to a cyclohexene derivative and ring expansion of the product.

Forming (2+2) adducts like **146**, or ring expanded products like **147**, is more synthetically attractive than simple elimination-addition reactions because the products are more complex and give rise to rings that are more synthetically difficult to achieve, such as cyclobutene in **146**.

The harsh basic conditions and low yields are drawbacks to this methodology, and thus an alternative method that was analogous to benzyne synthesis was employed. Guitián and coworkers generated **144** by the fluoride-

assisted β -elimination of a trimethylsilyl-substituted vinyl triflate **148**, which was trapped using the simple α -pyrone derivative **149** to form **150** (by intermediate **151**) via a (4+2) Diels-Alder reaction (Scheme 47).¹²⁵ This was the first, and until recently, only known (4+2) reaction of cyclohexyne.

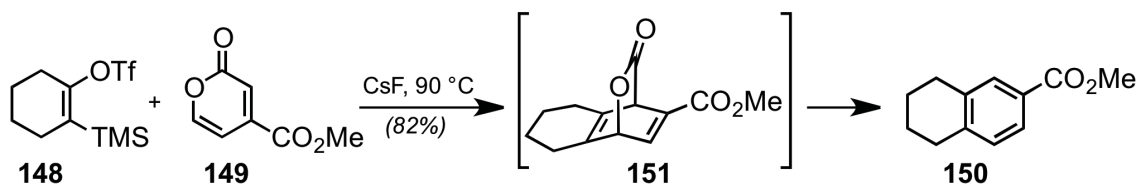

Scheme 47. (4+2) Cycloaddition of an α -pyrone to cyclohexyne.

The formation of cyclohexyne via base-promoted elimination of a substituted cyclohexene was later improved by the use of a hypervalent iodide salt.¹²⁶ Fujita *et al.* were the first to report the formation of **144** via the β -elimination of a cyclohexenyl(phenyl)iodonium tetrafluoroborate salt **152** using milder basic conditions than 1-chlorocyclohexene had required.¹²⁷ This resulted in less isomerization to the allene and better yields of elimination-addition products, although often mixtures of regioisomers were produced (Scheme 48). The regioselectivity was hypothesized to be the result of the difference in LUMO populations between the two carbons of the cyclohexyne.¹²⁸

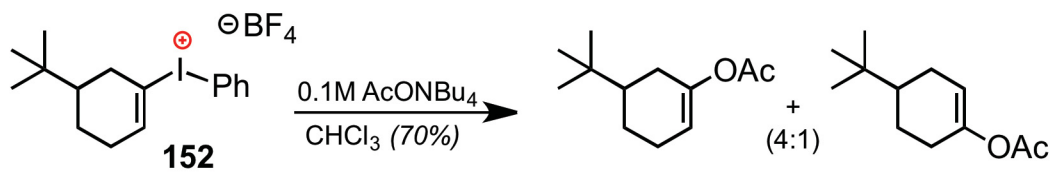

Scheme 48. The generation and trapping of cyclohexyne from iodonium salt **152.**

Cyclohexyne **144** generated from iodonium salt **153** was also shown to undergo (2+2) additions with enolates.¹²⁹ When KOCEt₃ was used to generate **144**, ring expanded products were predominantly observed (Table 5).

Table 5. Ring-expanded cyclic ketones.

| Entry | Substrate | Product | % Yield |
|-------|-----------|---------|-----------------|
| | | | |
| 1 | | | 67 ^a |
| 2 | | | 76 ^b |
| 3 | | | 64 ^a |
| 4 | | | 51 ^c |
| 5 | | | 74 ^a |

^a Combined yield with its deconjugated isomer. ^b Cyclobutene adduct isolated and opened in a successive step. ^c Product was obtained as a 2.5:1 mixture of *E* and *Z* isomers.

4.2 Metal Complexes of Cyclohexyne

The previous examples are indirect evidence for the existence of cyclohexyne as a short-lived intermediate, but cyclohexyne cannot be isolated and characterized due to its highly reactive nature. Cyclohexyne can, however, complex to transition metals, which allows its characterization by x-ray crystallography, and the complex can be used in organometallic reactions. The first transition metal complexes of cyclohexyne reported were platinum complexes (Scheme 49).¹³⁰⁻¹³⁴ Treatment of 1,2-dibromocyclohexene with sodium amalgam in the presence of $\text{Pt}(\text{PPh}_3)_3$ generated the η^2 -complex **154**, which could then be treated with TFA to form the σ -cyclohexenyl complex **155**. The triphenylphosphine ligands of **154** were substituted for 1,2-bis(diphenylphosphino)ethane (dppe or diphos) to generate **156**, which was more susceptible to attack by weak acids, such as methanol that formed the σ -cyclohexenyl complex **157**.

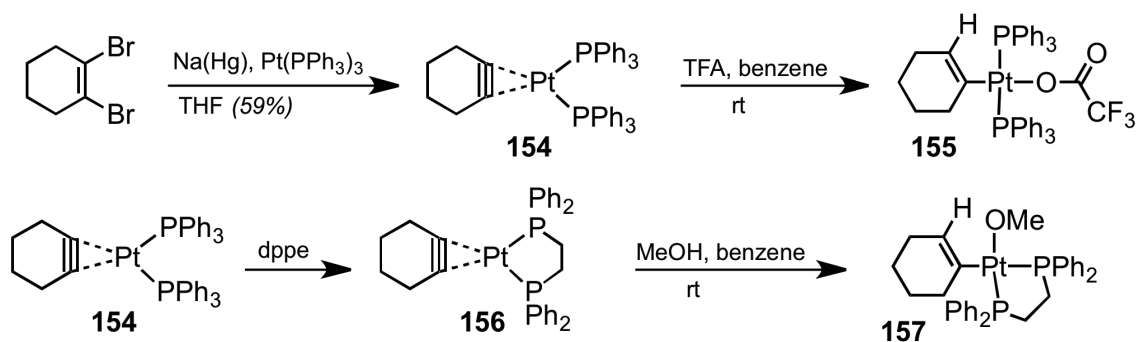

Scheme 49. Cyclohexyne complexes with platinum.

Similar complexes have also been made using palladium [Pd(PPh₃)₄]¹³⁵ and nickel [Ni(η^2 -C₂H₄)(PPh₃)₃, Ni(η^2 -C₂H₄)(PEt₃)₃, and Ni(η^2 -C₂H₄)(dcpe)],¹³⁶ all of which have been useful in derivatizing cyclohexyne into more functionalized species.¹³⁷ Platinum complexes, for example, reacted with dimethyl acetylenedicarboxylate (DMAD), carbon dioxide and acrolein to form insertion products **158**, **159** and **160**, respectively (Scheme 50). Furthermore, nickel complexes undergo two insertion reactions. Nickel η^2 -complex **161** was able to undergo an insertion reaction with carbon dioxide to form **162**, which was then converted to **163** by the insertion of DMAD.

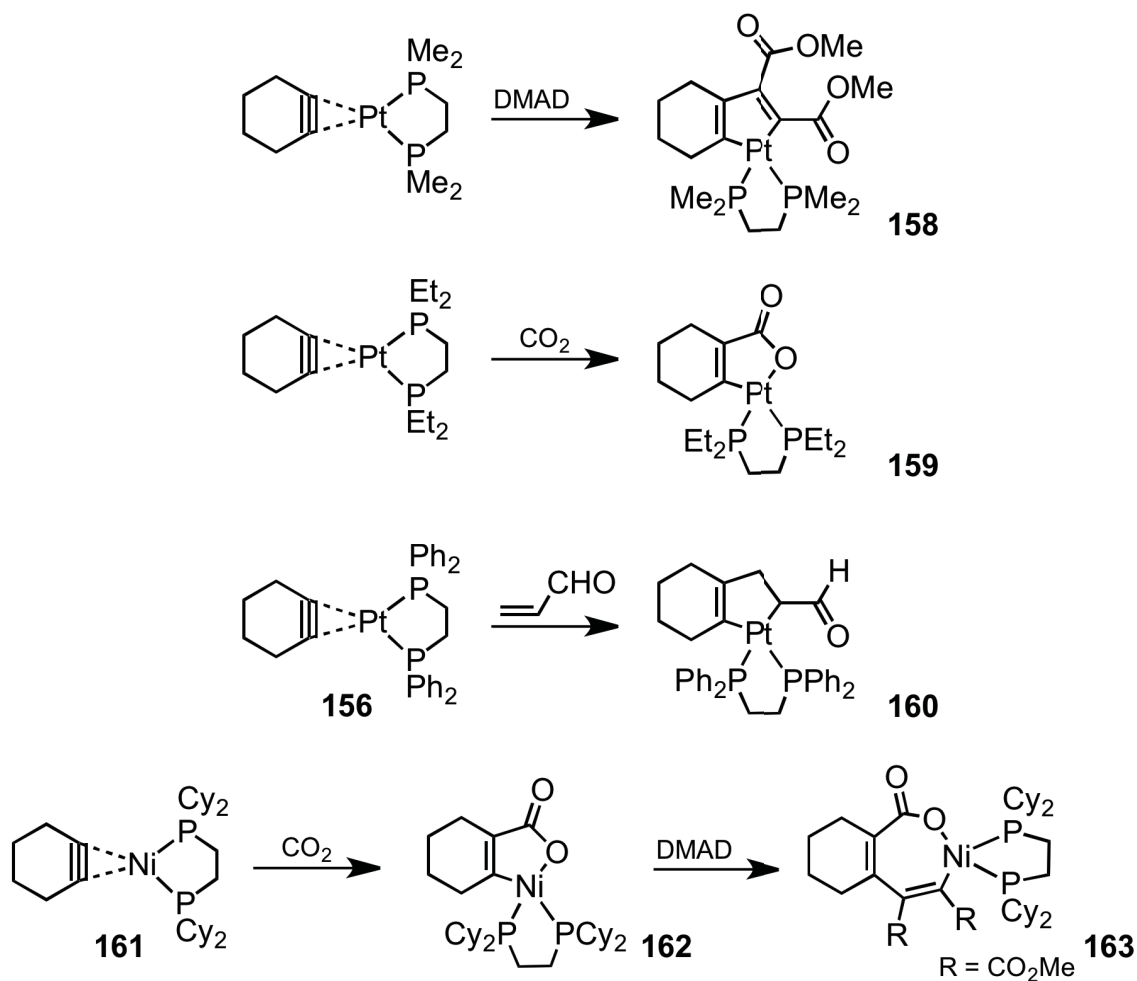

Scheme 50. Reactions of organometallic complexes of cyclohexyne.

4.3 Applications of Cyclohexyne in Total Synthesis

One of the benefits of cyclohexyne as an electrophile is it provides a way of appending a six-membered ring. Carreira and coworkers had shown that Fujita's method of generating cyclohexyne could be used to expand five-membered ring enolates to cyclohexene-appended seven-membered rings, which they used to produce the core of sandresolide A.¹²⁹ They later used this methodology in the

divergent syntheses of guanacastepenes N and O.¹³⁸ The guanacastepenes are a structurally diverse class of diterpenes that have activity against drug-resistant strains of *E. faecalis* and *S. aureus*. Guanacastepenes N and O are interesting from a synthetic point of view, in that they contain annealed five-, seven-, and six-membered rings. Guanacastepenes N **164** and O **165** are diastereomeric at C-13 (denoted by an asterisk in Scheme 51).

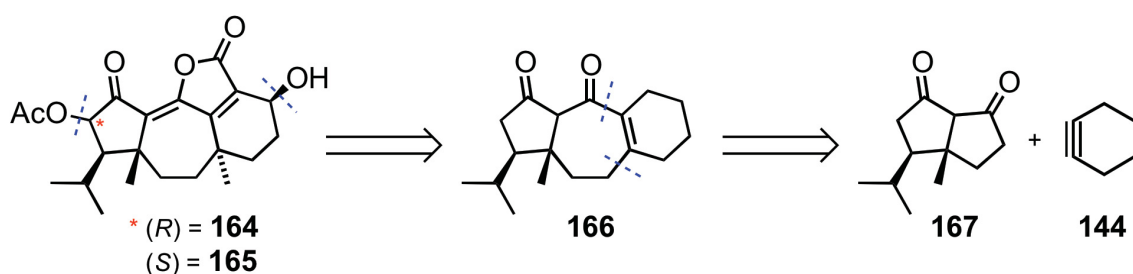

Scheme 51. Retrosynthesis of guanacastepenes N and O.

In their retrosynthetic analysis, the hydroxyl and acetate appendages were envisioned to be installed at a late stage into intermediate **166**. Previous work by Gampe *et al.* highlighted that annealed seven-, and six-membered rings could be obtained by the (2+2) cycloaddition of cyclohexyne to the enolate of a five-membered ring, followed by a ring opening (which occurred spontaneously in some instances, but could also be induced by the addition of *t*BuOK).¹²⁹ Thus, intermediate **166** was seen as the product of a cycloinsertion of cyclohexyne **144** with **167**.

Because **167** contains two enolizable ketones, and therefore cycloinsertion could potentially occur onto either of the five-membered rings, the ketal protected analog **168** would have to be used instead. They managed to prepare precursor **168**

in six steps (31% overall yield) from commercially available methyl 3,3-dimethylacrylate. The enolate and cyclohexyne were generated *in situ* using iodonium salt **153** and KOEt₃, which upon mixing formed the (2+2) adduct **169** (Scheme 52). The cyclobutene would not undergo ring-opening using the typical conditions (*t*BuOK, THF), thus alternative methods were pursued. They were able to open the ring using Fe₂(CO)₉ and then the resulting double bond was isomerized using DBU to form the conjugated product **170** in 51% yield.

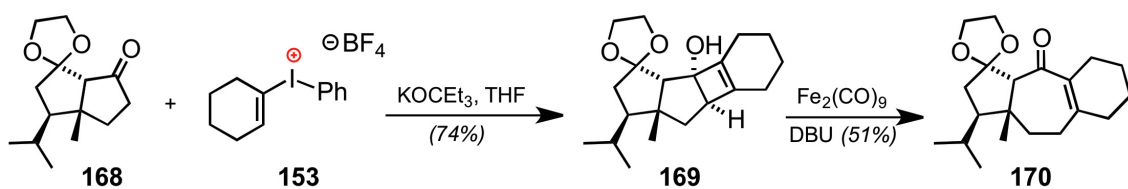

Scheme 52. The cycloinsertion of cyclohexyne in the total synthesis of guanacastepenes N and O.

The syntheses of guanacastepenes N and O were accomplished from **170** in fourteen more steps, which were largely due to the difficulty in functionalizing the six-membered ring.

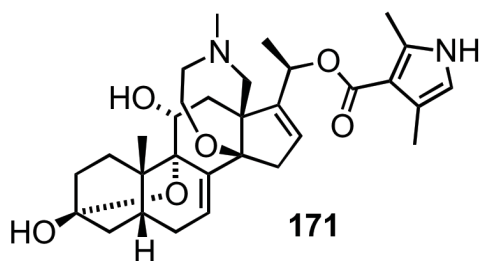
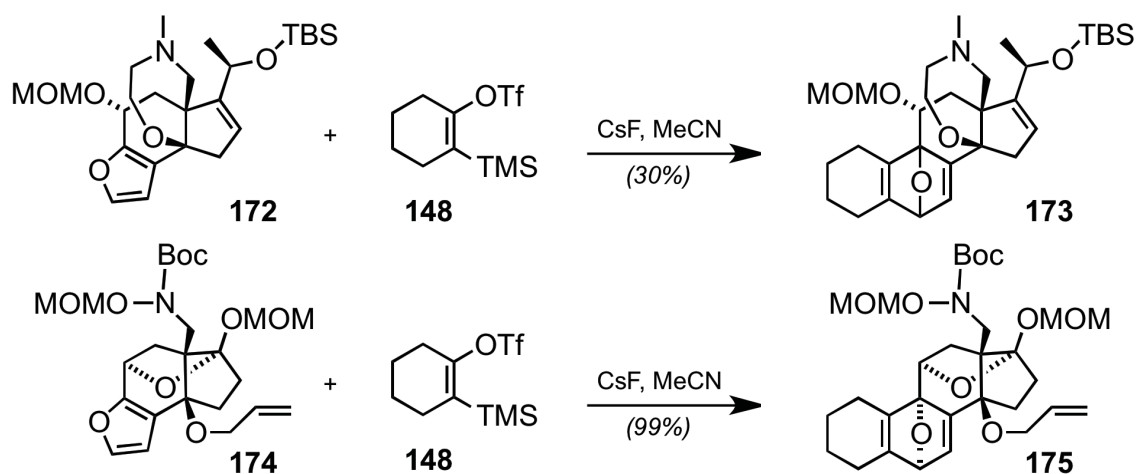

Figure 11. Batrachotoxin.

Devlin and Du Bois also made use of cyclohexyne in their modular synthesis of core structures of batrachotoxin (Figure 11).¹³⁹ Their approach made use of a furan-appended intermediate that could undergo (4+2) reactions with various dieneophiles, including cyclohexyne. They initially tried the Diels-Alder reaction at a late stage using intermediate **172** and cyclohexyne precursor **148**, but they obtained a low yield with low facial selectivity, forming a 3:1 mixture of diastereomers **173** (Scheme 53). They then tried the Diels-Alder reaction onto **174**, a synthetic precursor to **172**, and observed much greater selectivity (20:1 *dr*) producing **175** in nearly quantitative yield. They also mentioned that when the same reaction was carried out with iodonium salt **153** as a cyclohexyne precursor, no trace of **175** was observed.



Scheme 53. Synthesis of batrachotoxin core structures.

Although the use of cyclohexyne in total synthesis is limited, it could have a much higher impact if more was understood about its reactivity and selectivity. Benzyne has had considerable impact in the scientific community (“benzyne” has

been cited over 3000 times in the literature, whereas “cyclohexyne” has barely been cited 100 times), because cyclohexyne has not yet been studied thoroughly.

4.4 Results and Discussion

4.4.1 Introduction

The overall goal of this project was to examine reactions of cyclohexyne and substituted derivatives with dienes to better understand their (4+2) reactions. Aside from the work of Atanes *et al.* on α -pyrones (two examples)¹²⁵ and the work of Devlin and Du Bois on batrachotoxin (two examples),¹³⁹ there are no other examples of cyclohexyne participating in Diels-Alder reactions. The method chosen for generating cyclohexynes was via trimethylsilyl vinyltriflates, because this method avoids the strongly basic conditions that may not be compatible with other functional groups, and it is the only method known to produce (4+2) cycloadducts.

4.4.2 Diels-Alder Reactions of Cyclohexyne 144

Cyclohexyne precursor **148** was prepared starting from cyclohex-2-en-1-one in four steps. 1-Bromocyclohex-2-enone (**176**) was made in 97% yield by the bromination and subsequent dehydrobromination of cyclohex-2-en-1-one (Scheme 54).¹⁴⁰ The product decomposed if left at rt over 24 h, but it could be stored at –20 °C for more than a year. The ketone function of **176** was then protected as an ethylene glycol ketal, following a standard procedure, forming **177**.¹⁴¹ This protection was necessary to prevent the formation of an enolate in the following

step. With ketal **177** in hand, a lithium-halogen exchange reaction was undertaken to generate an organolithium intermediate, which was trapped subsequently with trimethylsilyl chloride, forming **178** upon hydrolysis of the ketal during workup.¹⁴² A Wurtz-Fittig coupling using sodium metal and trimethylsilyl chloride was also done, but the yield was slightly lower and the reaction itself was more hazardous.¹⁴³ A 1,4-reduction of **178** was effected smoothly using L-Selectride (lithium tri-*sec*-butylborohydride), and the resulting enolate was trapped by a triflyl-delivering agent forming **148**.¹⁴⁴ Yields of **148** were initially quite low due to decomposition on silica gel during chromatography. This was circumvented by treating the silica gel with a small amount of triethylamine before loading the column.

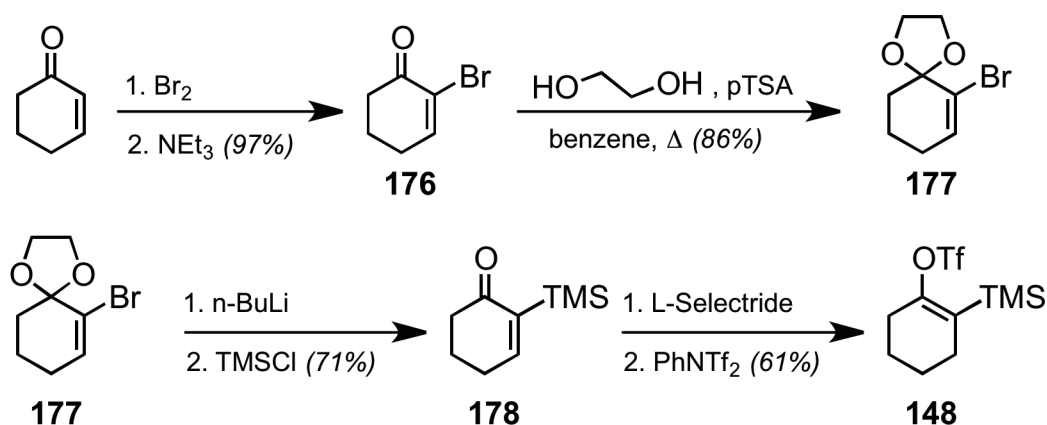

Scheme 54. Preparation of cyclohexyne precursor 148.

The literature was sometimes vague and often inconsistent on the conditions used to generate cyclohexyne from trimethylsilyl vinyltriflates. Atanes *et al.* did not specify the solvent used, but they did specify that reactions with α -pyrones using CsF required heating between 90-100 °C and a reaction time of over 30 h (see Scheme 47, page 117).¹²⁵ Peña and coworkers reported that cyclohexyne

oligomerized when generated using CsF at rt in acetonitrile, forming its trimer **179** in 30% yield (they stated that using 10 mol% of Pd(PPh₃)₄ increased the yield of trimer to 64%) (Scheme 55 A).¹⁴⁵ They also mentioned that the tetramer **180** could also be formed, but only in the presence of Ni(COD)₂ (10 mol%) (Scheme 55 B).¹⁴⁶ These results were in contrast with a previous report by Wittig and Mayer that stated that tetramerization of cyclohexyne occurred when 1,2-dihalogenated cyclohexenes were reacted with magnesium or lithium amalgam.¹⁴⁷ Yoshida *et al.* performed distannylation reactions of cyclohexynes generated using KF (3 equiv.) and 18-crown-6 (3 equiv.), with hexabutyliditin, Pd(OAc)₂ (2 mol%), and *tert*-octyl isocyanide (30 mol%) in THF at rt, with yields ranging from 60-90% over the course of three to four hours, forming **181** (Scheme 55 C).¹⁴⁸ Finally Allan *et al.* generated cyclohexyne using CsF in acetonitrile with methyl acetoacetate with heating to 80 °C to give acyl-alkylated cyclohexene **182**, followed by condensation with ammonia to provide 3-hydroxyisoquinoline product **183** (Scheme 55 D).¹⁴⁹

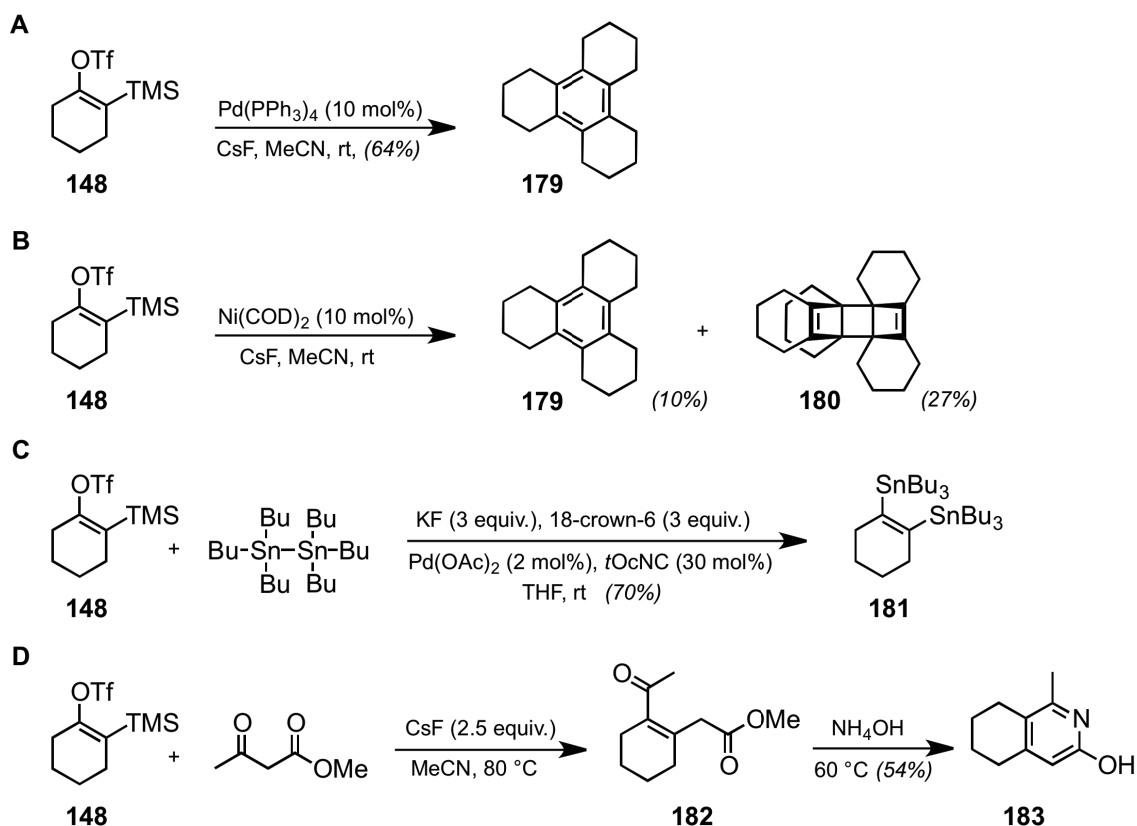





Scheme 55. A) Trimerization of cyclohexyne. B) Tetramerization of cyclohexyne. C) Distannylation of cyclohexyne. D) Acyl-alkylation of cyclohexyne.

Based on these results, it would appear that cyclohexyne could be generated at rt in acetonitrile or in tetrahydrofuran, but that increasing the temperature might be necessary in order to induce certain reactions. Therefore, reactions were carried out in both solvents, using three equiv. of CsF and **148** without any nucleophile, to see which compounds would be produced and in what sort of yield they could be obtained. This would give an approximate yield of cyclohexyne **144**. CsF, even after drying under reduced pressure at 100 °C for several hours, had poor solubility in both solvents, and TLC analysis showed no sign of conversion to cyclohexyne oligomers. The reaction mixtures were then heated to 60 °C to induce reaction, but

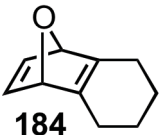
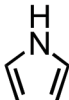
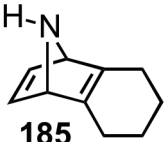
the only reaction that appeared to work was in THF. The result of this was a 17% yield of tetramer **180** and no sign of trimer **179**. These conditions were then used to trap dienes, but the yields were low and the resulting reaction mixtures were always contaminated with about 20% of the tetramer **180**.

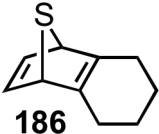
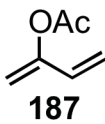
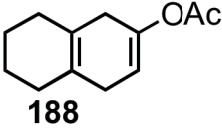
Table 6. Reactions of cyclohexyne with dienes.

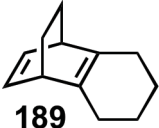
| Entry | Diene | Product | % Yield |
|-------|---|--|---------|
| 1 |  |  184 | 31 |
| 2 |  |  185 | 0 |
| 3 |  |  186 | 0 |
| 4 |  187 |  188 | 35 |
| 5 |  |  189 | 20 |

Reaction conditions: **148**, diene (3 equiv.), CsF (3 equiv.) in THF heated to 60 °C for 20 h.

Cyclohexyne was generated in the presence of three heteroaromatic nucleophiles; furan, pyrrole and thiophene. The reaction with furan gave the (4+2) product **184** in 31% yield, whereas pyrrole and thiophene did not yield any of the

expected products **185** and **186**. The yield of **184** appeared low when compared to Devlin and Du Bois' yield of 99% when the reaction was done on their more complex furan derivative **174** (see Scheme 53, page 125).¹³⁹ The reason that their yield was so high was possibly because they used three equiv. of cyclohexyne precursor **148**, and so their limiting reagent was the furan derivative **174**. Therefore, it is possible that one equiv. of **148** would have only formed their product **175** in one-third the yield.

Cyclohexyne also reacted with acetate-substituted 1,3-butadiene **187**, which was prepared from methyl vinyl ketone and acetic anhydride, providing **188** in 35% yield. 1,3-Cyclohexadiene also reacted with cyclohexyne, providing **189** in 20% yield. The lack of functional groups on **189** made it difficult to ionize it for mass spectrometry using ESI, thus a silver complex was formed by stirring **189** in a 1:1 solution of methanol and acetonitrile containing AgNO₃.

Because the yields were not as high as desired, an alternative source of fluoride was used to generate cyclohexyne. When **148** was allowed to react with tetrabutylammonium fluoride (TBAF) at rt, the reaction was conducted in less than five minutes and formed tetramer **180** in 50% yield (Scheme 56). This result suggested that cyclohexyne was generated more efficiently from TBAF because CsF only gave **180** in 17% yield. This increase in yield was likely due to the increased solubility of the fluoride anion. When the same conditions were employed using three equiv. of furan as a nucleophile to trap cyclohexyne, it was disappointing that only 20% of the trapped product **184** was obtained, accompanied by 60% of the tetramer. The yield of **184** was increased to 72% by running the

reaction with furan as the solvent, which suppressed the formation of tetramer to only 5%. This method, however, required a large excess of TBAF.

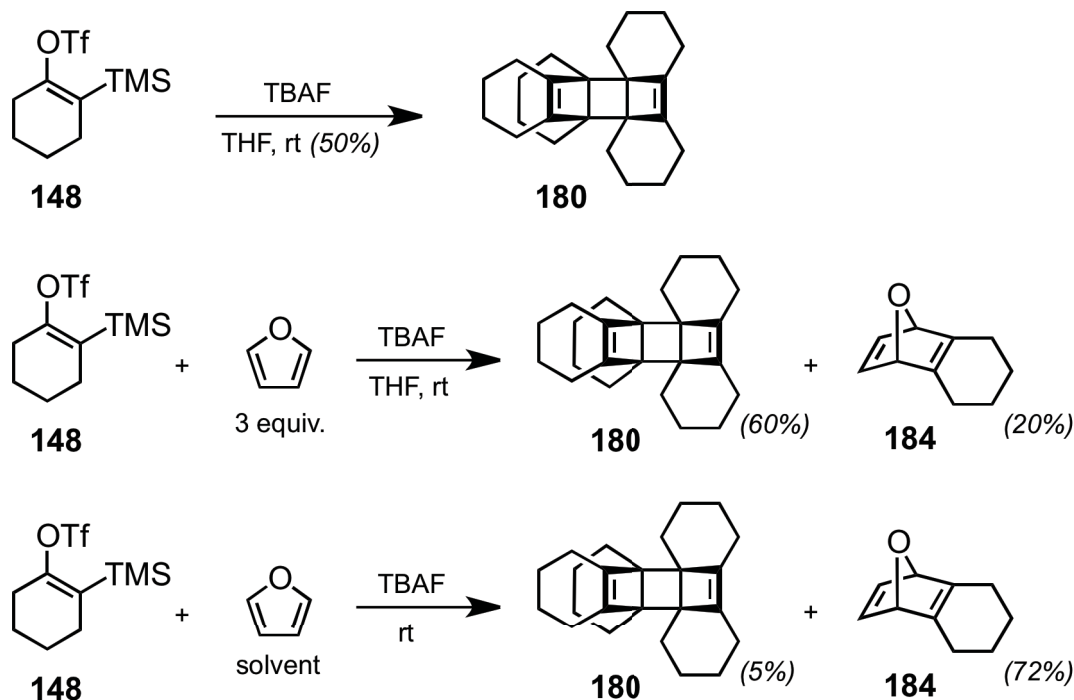

Scheme 56. Generating cyclohexyne using TBAF.

4.4.3 Diels-Alder Reactions of a Substituted Cyclohexyne

The regioselectivity of cyclohexynes in elimination-addition reactions was studied using substituted iodonium salt precursors, and the results were limited to seven examples.¹²⁸ The selectivity was hypothesized to result from LUMO populations.^{127,128,150} The only example of regioselectivity in (2+2) reactions of a substituted cyclohexyne was reported by Fixari *et al.* in 1976 using a chloro-substituted cyclohexene (see Scheme 46, page 116). Since the (2+2) reaction was likely to be a two-step process, it was postulated that the first bond was made from

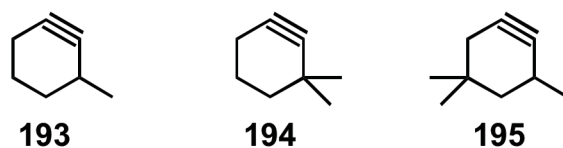
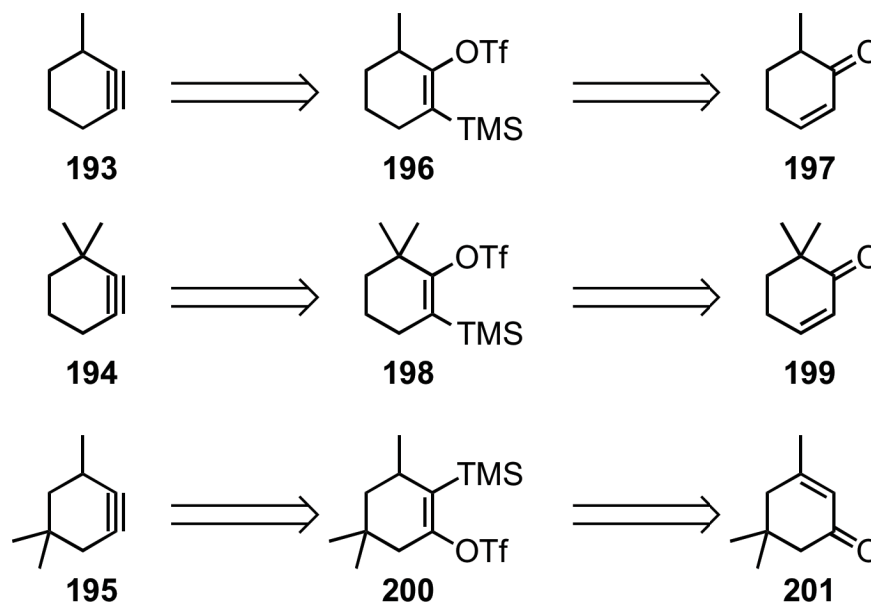

Figure 12. Alkyl-substituted cyclohexynes.

The preparation of these substituted cyclohexynes was envisioned to proceed via the same reactions as those that were employed for the formation of **148**. The monosubstituted cyclohexyne precursor **196** could be prepared from 6-methylcyclohex-2-en-1-one **197**, the disubstituted cyclohexyne precursor **198** could be prepared from 6,6-dimethylcyclohex-2-en-1-one **199**, and the trisubstituted cyclohexyne precursor **200** could be prepared from isophorone **201** (Scheme 58).



Scheme 58. Retrosynthesis of substituted cyclohexynes 193, 194, and 195.

The methyl-substituted cyclohexenones **197** and **199** were obtained from the methylation of cyclohex-2-enone using lithium diisopropylamide (LDA) and iodomethane (Scheme 59).¹⁵¹ Bromination of **197** and **199** provided **202** and **204**, respectively, but, protection as their ethylene glycol ketals, **203** and **205**, was unsuccessful. Attempts of forming the desired ketals using Noyori's conditions¹⁵² that uses the bis-TMS ethylene glycol derivative **206** were also unsuccessful. It was presumed that the ketone was simply too sterically congested for ketalization, and thus a new approach needed to be taken.

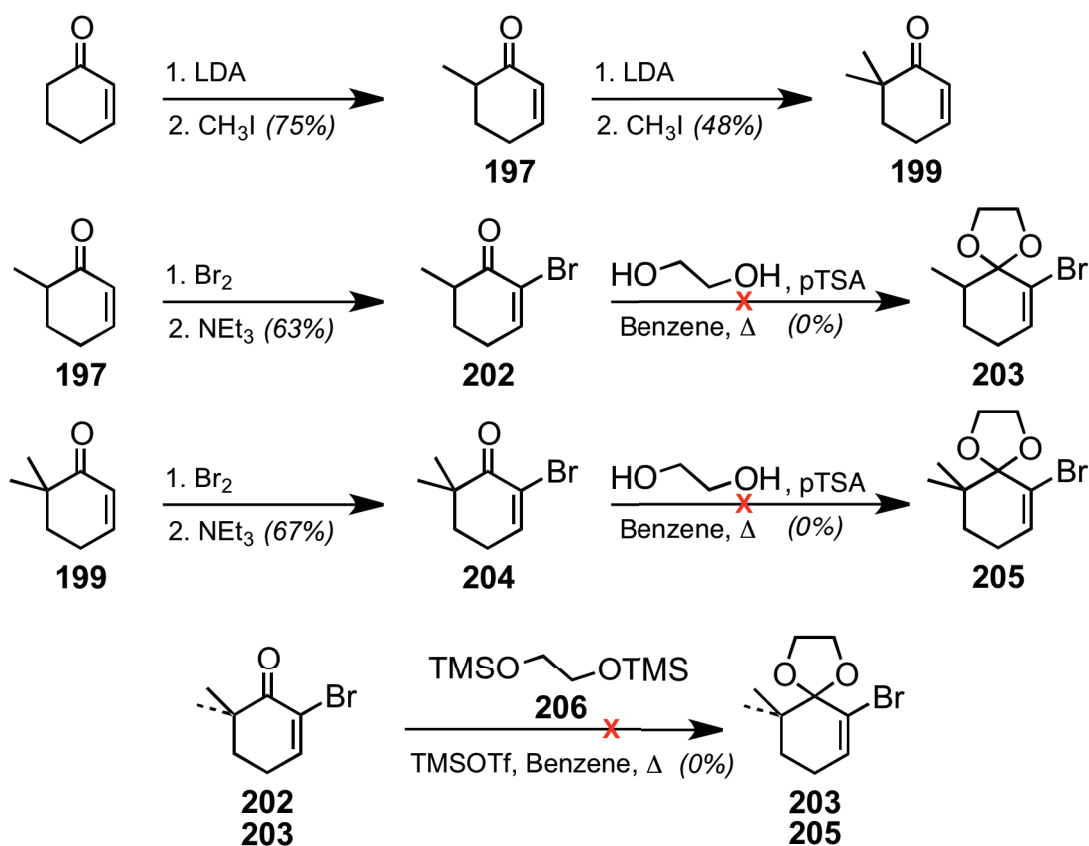

Scheme 59. Attempts at preparing methylated cyclohexynes from 2-cyclohexenones.

To avoid the issue of having a congested ketone for ketalization, methylation was to be done at a later stage. The same methylation conditions were employed using the trimethylsilyl-substituted cyclohexenone **178**, forming monomethylated compound **207** and dimethylated compound **208** (Scheme 60). Attempts at trapping the enolates of **207** and **208** with PhNTf₂ did not produce any of the desired compounds **209** and **211**, but instead the reduced compounds **210** and **212** were recovered. This result indicated that the reduction step had occurred, but the enolate had difficulty in accepting a triflyl substituent from PhNTf₂. Therefore, a more reactive triflyl delivering agent, Comins reagent **213**,¹⁵³ was tested, but, alas, the desired triflates were not produced.

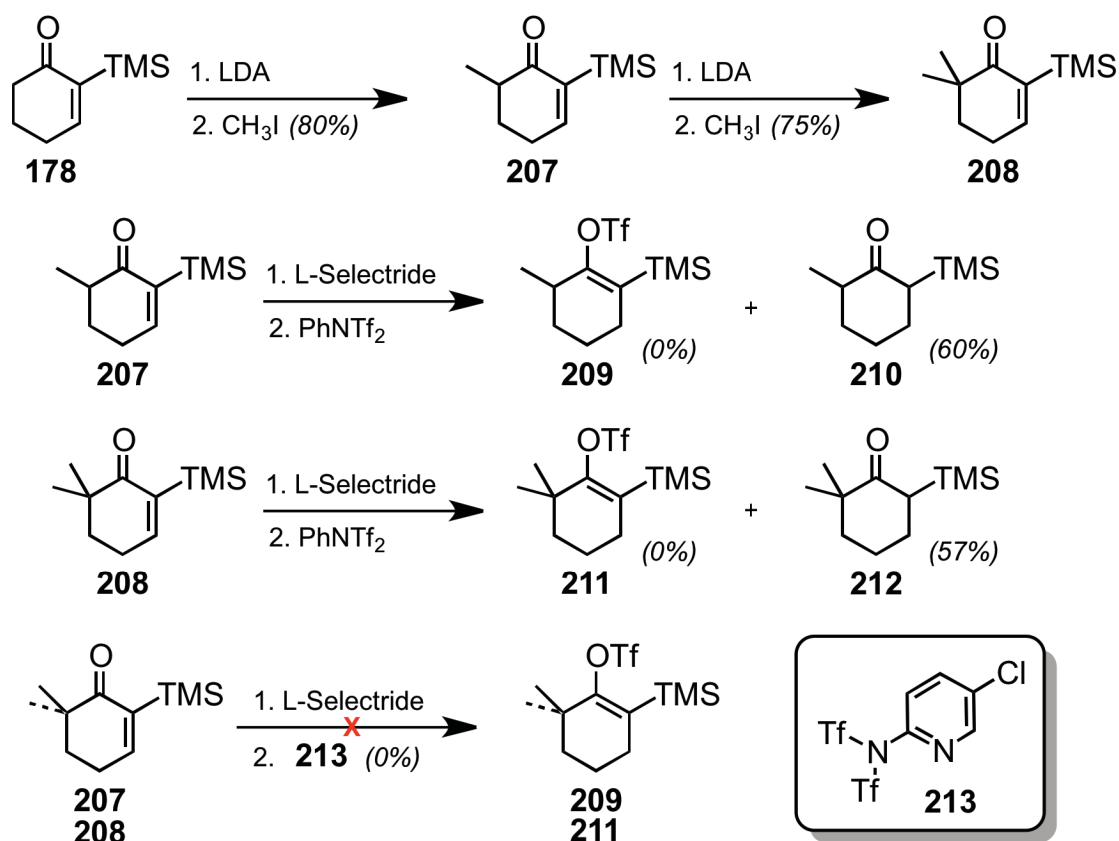

Scheme 60. Attempts at forming methyl-substituted cyclohexyne precursors.

A new approach was undertaken to install the methyl groups at the 3-position instead of the 6-position. Attempts at the α -bromination of 3-methylcyclohex-2-en-1-one using the same method of bromination and debromination provided **214** in only 7% yield along with a mixture of phenols **215** and **216** (Scheme 61). Instead, **214** was formed in higher yield using tetrabutylammonium tribromide (TBATB) and potassium carbonate.¹⁵⁴ Now that the methyl substituent was further away from the carbonyl, the ethylene glycol ketal **217** was obtained without any complications. It was then converted to compound **218** via a lithium-halogen exchange reaction followed by TMSCl, then reduced with L-Selectride followed by the addition of PhNTf₂ to give **219**.

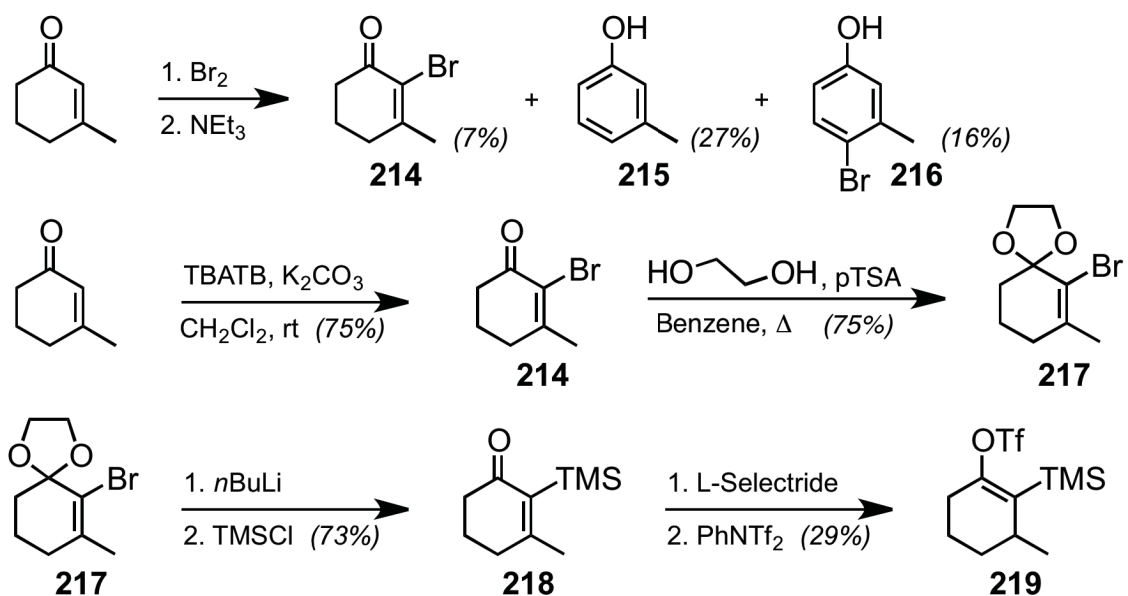

Scheme 61. The preparation of methyl-substituted cyclohexyne precursor **219**.

Due to the low yield of **219**, other reagents for 1,4-reduction were explored (Table 7). Reagents were first tested on the unsubstituted precursor **178** before attempting reactions on **218**. N-Selectride (sodium tri-*sec*-butylborohydride) gave the best results, as **148** was produced in 96% yield. K-Selectride (potassium tri-*sec*-butylborohydride) produced a 1:1 mixture of **148** and the reduced product **220**. Both LS-Selectride (lithium trisamylborohydride) and copper hydride (generated *in situ* by the reaction of CuI and LiAlH₄)¹⁵⁵ gave **220** only. Since N-Selectride had given the best results with **178**, it was used to generate **219** from **218**, increasing the yield to 48%.

Table 7. The 1,4-reduction of 178 and the trapping of its enolate.

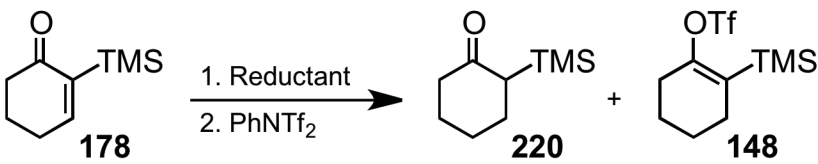

| Entry | Reductant | Product | % Yield |
|-------|-------------------------|------------------|-----------------|
| 1 | L-Selectride | 148 | 61 ^a |
| 2 | N-Selectride | 148 | 96 |
| 3 | K-Selectride | 148 + 220 | 56 ^b |
| 4 | LS-Selectride | 220 | 48 |
| 5 | CuI, LiAlH ₄ | 220 | 76 |

Reaction conditions: **178**, reductant (1.1 equiv.), THF, -78 °C, 1 h; then PhNTf₂ (1 equiv.) in THF, -78 °C →rt. ^a Addition of TMEDA resulted in a 58% yield of **148**. ^b 1:1 mixture of products.

The dimethyl-substituted cyclohexyne precursor was expected to be obtained relatively simply using a Gillman reagent to methylate the β -position, while a subsequent trapping of the enolate would occur using PhNTf₂. However, when **218** was reacted with Me₂CuLi (generated *in situ* from CuI and MeLi),¹⁵⁶ followed by PhNTf₂, no triflate product **221**, nor any addition product was observed (Scheme 62). The reaction was tried again using CuBr•DMS and MeMgBr to generate the cuprate,¹⁵⁷ but again this method did not provide any triflate product **221** and only starting material was recovered. A higher order cuprate was then generated *in situ* from CuCN and MeLi,¹⁵⁸ and, although this procedure appeared to generate the addition product **222**, none of the triflate product **221** was obtained, and the majority of the recovered material was the starting ketone **218**. The fact that **222**

and **218** appeared as a single spot on TLC made it difficult to track the progress of this reaction. To see if there was any issue with reactive copper species reacting prematurely with PhNTf₂, and thus preventing the formation of the triflate, 3-methylcyclohex-2-en-1-one was reacted with Me₂CuLi followed by PhNTf₂. The result was the triflate product **223** in high yield. The only difference between 3-methylcyclohex-2-en-1-one and **218** was an α-TMS substituent, and so it was likely to be inhibiting both the alkylation and *O*-sulfonylation steps.

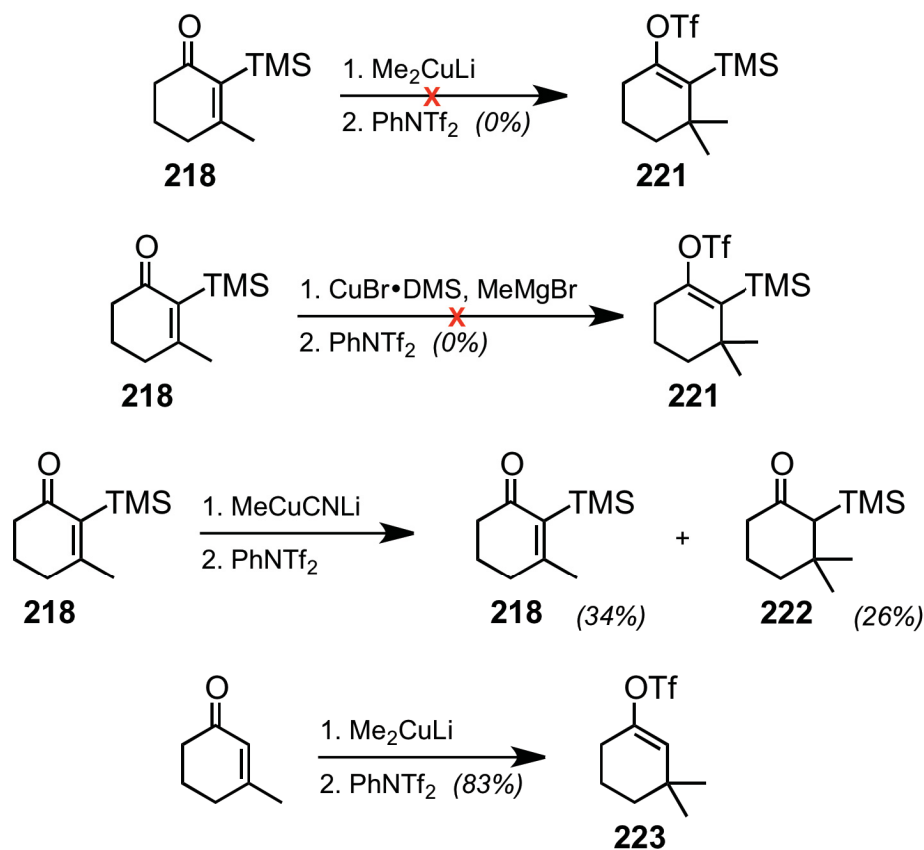

Scheme 62. Attempts at generating a dimethyl-substituted cyclohexyne precursor.

The methyl-substituted cyclohexyne precursor **219** was reacted with furan, as furan had worked well with an unsubstituted cyclohexyne, to see if there would be any diastereoselectivity. The result was a complex mixture of tetrameric diastereomers **224** and a 2:1 *dr* of the Diels-Alder adduct **225** (Scheme 63)

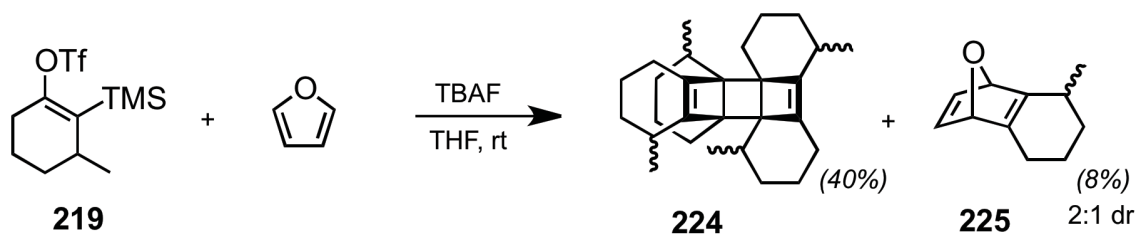

Scheme 63. Diastereoselective Diels-Alder of a methyl-substituted cyclohexyne.

Although it is difficult to deduce which diastereomer was predominantly formed, the fact that this reaction had any selectivity at all was surprising. Computational results suggested that a reactive substrate like cyclohexyne would have almost no energy barrier for reaction therefore no selectivity.¹⁵⁹ This *endo-exo* selectivity was essentially controlled by the relative position of the methyl group, where one of the transition states had the methyl group pointing toward the diene moiety **226**, and the other had the methyl group pointing toward the oxygen **227** (Figure 13).

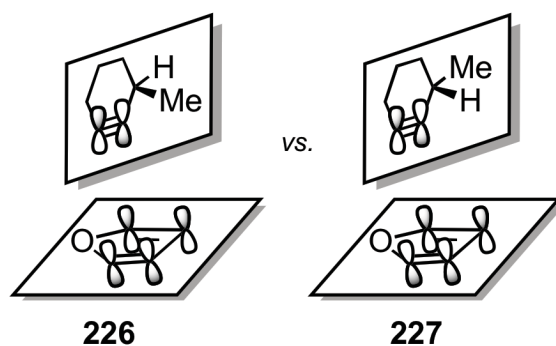
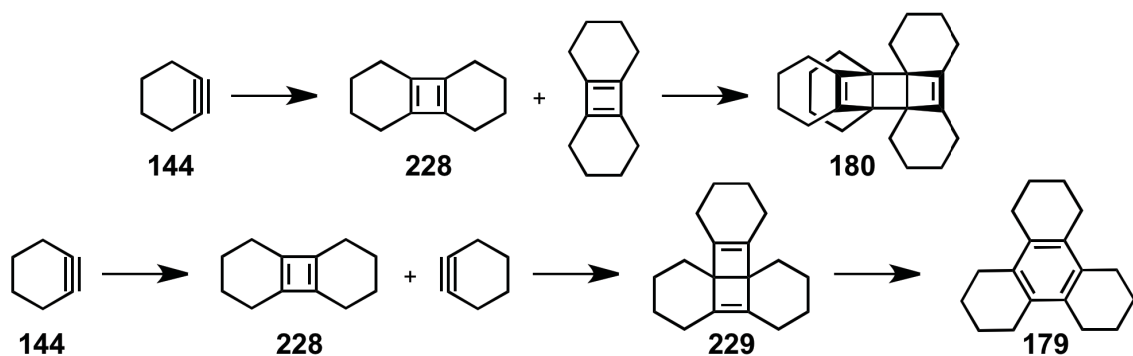

Figure 13. Transition state geometries of the diastereoselective Diels-Alder reaction.

Before continuing with more examples, it was desirable to assess if there was any way that the formation of the tetramer could be suppressed.

4.4.4 Tetramerization of Cyclohexyne

The formation of tetramer in such high yields was a little puzzling. According to Wittig and Weinlich, the tetramer **180** is formed by the Diels-Alder reaction of two molecules of the dimer **228**, whereas the trimer **179** is formed by the rapid conversion of the intermediate **229**, which is the result of a Diels-Alder reaction between the dimer **228** and cyclohexyne **144**. (Scheme 64).¹⁶⁰ The dimer **228** is a cyclobutadiene derivative, and it would undoubtedly be less thermodynamically stable than the product of a simple Diels-Alder of cyclohexyne **144** with an electron rich diene, such as furan.



Scheme 64. Mechanism proposed by Wittig for the formation of tetramer 180 and trimer 179.

The reaction of cyclohexyne precursor **148** with TBAF produced more tetramer at rt than CsF at 60 °C, and, as previously noted, CsF did not dissolve well in THF, therefore it was possible that the formation of the tetramer could be suppressed by controlling the rate that cyclohexyne **144** was generated. To this end, a series of halogen-substituted cyclohexene triflates **230** was prepared for lithium halogen-exchange reactions, so that cyclohexyne could be generated by the β -elimination of the triflate **231** (Scheme 65). Since this method of generating cyclohexyne would be done at colder temperatures, it was thought that cyclohexyne might be generated much more slowly. Rates of interchange have been observed to decrease from $I > Br > Cl$ and never with F.¹⁶¹ Although the mechanisms by which these exchanges proceed is still under debate, the balance of evidence suggests that lithium's exchange with iodine and bromine proceeds through an "ate-complex" whereas chlorine, although often unreactive in lithium-halogen exchanges, often initiates radical-mediated reactions.¹⁶¹ This process would also generate cyclohexyne in less steps than the previously used method (only three steps from **232**).

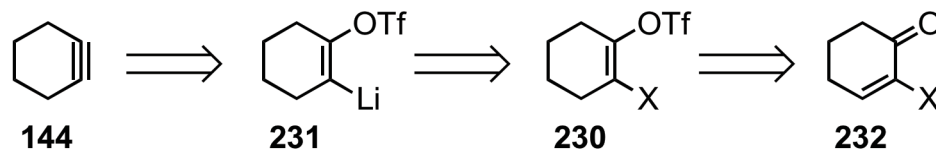

Scheme 65. Generating cyclohexyne from a halogenated cyclohexene triflate.

The bromo-substituted triflate **233** was prepared from **176**, then reacted with *n*-butyllithium in the presence of three equiv. of 2,3-dimethylbutadiene in the hope of generating the Diels-Alder adduct **234** (Scheme 66). Unfortunately, this reaction produced a large amount of tetramer **180**, as well as a small amount of trimer **179** but none of the desired compound **234**.

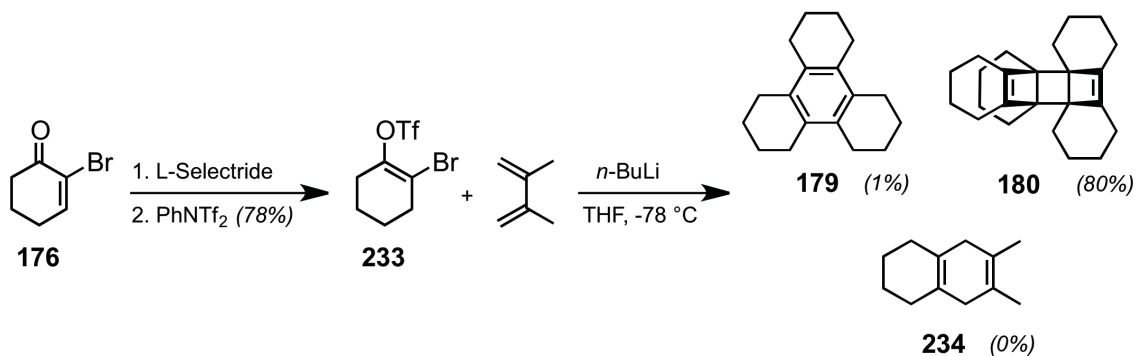

Scheme 66. Results of the generation of cyclohexyne from bromocyclohexene triflate **233.**

The iodo-substituted analog was made from the α -iodination of cyclohexenone to form **235** in 91% yield (Scheme 67). This was then converted to the cyclohexyne precursor **236** with L-Selectride and PhNTf₂ in a modest yield of 33%. The reaction with three equiv. of 2,3-dimethylbutadiene was unsuccessful in forming a Diels-Alder product, but trimer **179** was formed in 22% yield along with 55% of the tetramer **180**.

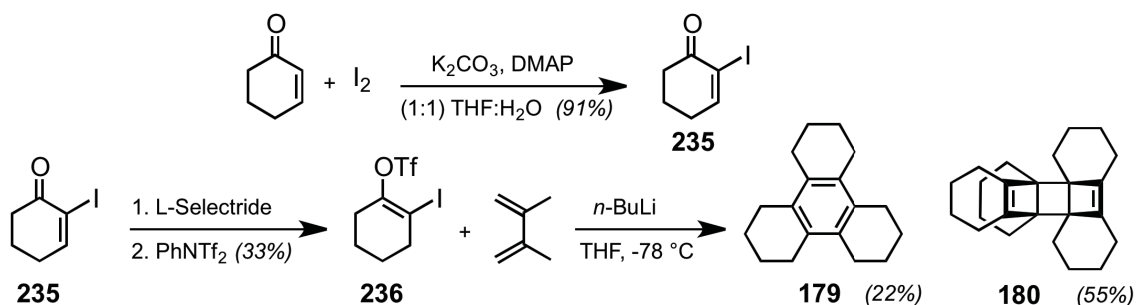

Scheme 67. The generation of cyclohexyne from iodocyclohexene triflate 236.

To finish off this series of halogen-substituted vinyl triflates, a chloro-substituted derivative was also prepared (Scheme 68). Cyclohexenone was α -chlorinated, generating **237** in 47% yield.¹⁶² This was then reduced with L-Selectride and the resulting enolate was trapped with PhNTf₂, giving **238** in 52% yield. Unfortunately, **238** was not able to generate any product under the conditions.

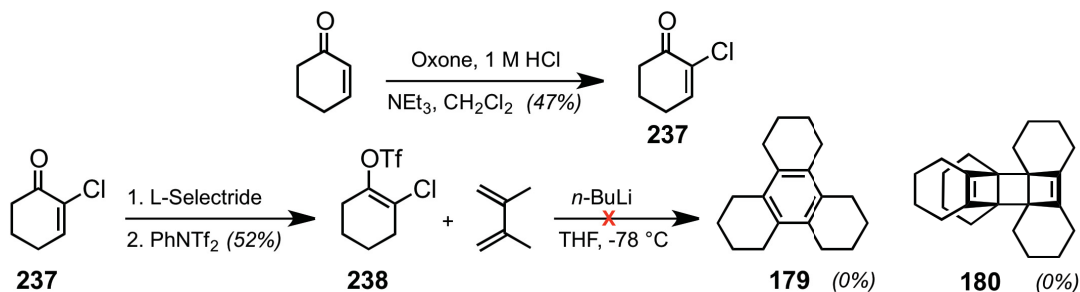

Scheme 68. The attempted generation of cyclohexyne from chlorocyclohexene triflate 238.

Although these methods did not provide any Diels-Alder adducts, the bromo-substituted triflate **233** did provide the tetramer **180** in 80%, which is the highest yield for this molecule to date. An X-ray crystal structure of **180** was obtained to confirm the stereochemistry (Figure 14).

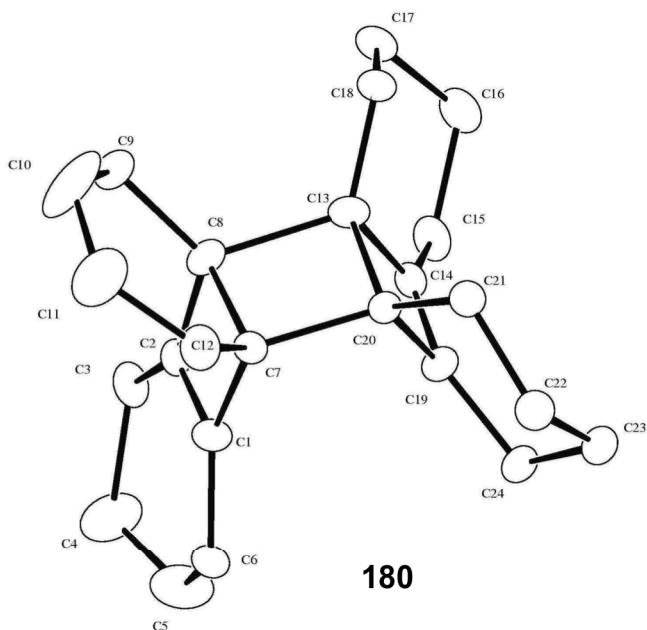
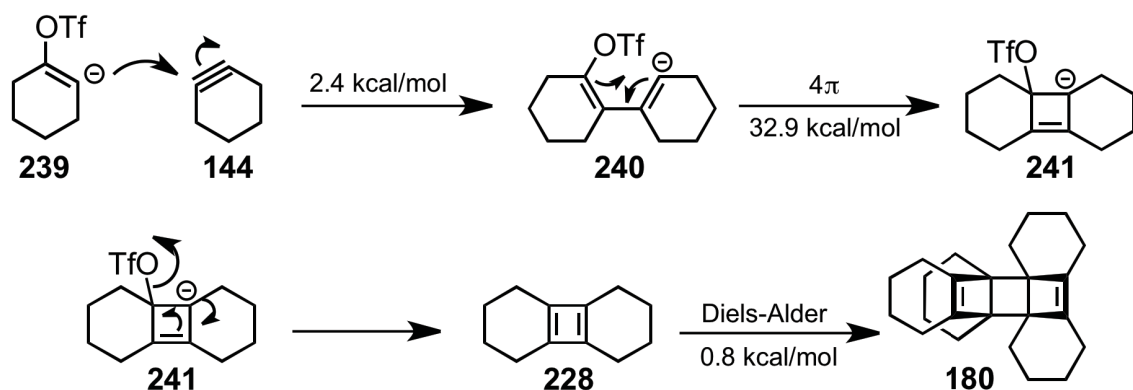

Figure 14. ORTEP of tetramer 180.

The oligomerization process did not proceed the same way with the halogen-substituted cyclohexyne precursors **233** and **236** as well as the trimethylsilyl-substituted cyclohexyne precursor **178**. The halogen-substituted compounds produced oligomers in roughly equal amounts, although the bromo-substituted compound **233** produced the tetramer in 80% yield, whereas the iodo-substituted compound **236** produced the tetramer in 55% yield (along with 22% trimer). The trimethylsilyl-substituted precursor **178** produced the tetramer in 50% yield using TBAF, but only in 17% yield when using CsF. To better understand the tetramerization process, some computational studies using the ω B97xD/6-311G(d,p) level of theory, were undertaken by Stephen Driscoll, an MSc student in our group, who examined the energies associated with the possible transition states during the course of this reaction.¹⁵⁹ The results suggested that dimerization likely

occurs from the attack of carbanion **239** onto cyclohexyne **144**, forming **240** with a barrier of only 2.4 kcal/mol (Scheme 69). This would then undergo a 4π -electrocyclization to generate the intermediate **241** with a transition state barrier of 32.9 kcal/mol (when calculated using formate rather than triflate). This intermediate would then eliminate the triflate to form the dimer **228**, which would then undergo a Diels-Alder reaction with another dimer, which was calculated to have a ΔG^\ddagger of only 0.8 kcal/mol.



Scheme 69. Computationally derived mechanism for the formation of tetramer **180.**

The energy barrier for the initial step of the dimerization is fairly low, and so it would seem that the best way to avoid this process would be to minimize the concentration of cyclohexyne. This could encourage cyclohexyne to react with the diene if the concentration of carbanion is very low.

4.5 Conclusions and Future Work

The library of Diels-Alder cycloadducts of cyclohexyne **144** with dienes was expanded to include a furan, an acetate-substituted 1,3-butadiene, and 1,3-cyclohexadiene, albeit that these were formed along with significant amounts of tetramer **180**. A methyl-substituted cyclohexyne was also prepared and its reaction with furan provided a 2:1 mixture of diastereomers, but a complex mixture of tetramers were also obtained in relatively high yield. Many different methods were assessed in an attempt to suppress the formation of the tetramer, including the use of TBAF as a source of fluoride, increasing the amount of diene, and using halogen-substituted cyclohexene triflates in lieu of the trimethylsilyl-substituted compound **148**. Although increasing the amount of diene did increase the yield of (4+2) product, a more atom-economical procedure would be best. The end goal is to be able to form complex cyclohexyne derivatives so they can better serve in synthesis, and it would be ideal if the diene to dienophile ratio could be 1:1.

To this end, future work will be to look at diluting TBAF at various concentrations and adding the mixture over a longer period of time to a solution of cyclohexyne precursor **148** and diene. If the cyclohexyne is generated slowly by this method, it should minimize any interaction it could have with another cyclohexyne molecule or with a carbanion intermediate. Once the formation of tetramer is significantly reduced, a larger library of (4+2) cycloadducts will be produced.

4.6 Experimental

4.6.1 General Information

Reactions were carried out using oven-dried Teflon-coated magnetic stir bars in oven-dried glassware (150 °C), sealed with rubber septa under a positive nitrogen atmosphere. Elevated temperatures were maintained using a silicone oil bath controlled with a thermostat device. Temperatures of 0 and -78 °C were achieved using ice/water and ethyl acetate/liquid nitrogen, respectively. Concentration *in vacuo* was achieved using a rotary evaporator (22 mmHg) with residual solvent being removed under high vacuum (5 mmHg).

All reagents were purchased from Sigma-Aldrich, Strem Chemicals, or Alfa Aesar and were used without further purification. Tetrahydrofuran (THF) was distilled over sodium benzophenone under a dry nitrogen atmosphere. CH₂Cl₂ was distilled over calcium hydride under a dry nitrogen atmosphere. Thin layer chromatography (TLC) was performed using 250 μm aluminum-backed F₂₅₄ silica gel plates from SiliCycle. The plates were visualized by ultraviolet light (254 nm) and treated with *o*-vanillin or potassium permanganate stains followed by heating on a hot plate. Flash chromatography was carried out on 230–400 mesh (40–63 μm) silica gel from SiliCycle.

Melting points (uncorrected) were acquired using a Fisher-Johns apparatus. ¹H and ¹³C NMR spectra were recorded from CDCl₃ solutions on a Bruker Avance 500 spectrometer. Chemical shifts (δ) are reported in parts per million (ppm)

downfield from tetramethylsilane and are referenced to the solvent peak (for CDCl₃, ¹H NMR: 7.26 ppm, ¹³C NMR: 77.16 ppm). High-resolution mass spectra (HRMS) were obtained on a Bruker microTOF Focus orthogonal ESI-TOF mass spectrometer. The X-ray crystal structure was provided by Dr. T. Stanley Cameron.

Structures were determined using ¹H and ¹³C NMR spectra, including two-dimensional NMR experiments (COSY, HSQC and HMBC).

4.6.2 Preparation and Characterization Data

2-Bromocyclohex-2-en-1-one (176)

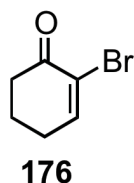

A solution of bromine (3.24 mL, 63.2 mmol) in CH₂Cl₂ (160 mL) was added dropwise over 1 h to a solution of cyclohex-2-en-1-one (6.0 mL, 62 mmol) in CH₂Cl₂ (160 mL) cooled to 0 °C. Triethylamine (14.4 mL, 103.5 mmol) was then added to the reaction mixture, and the mixture was stirred at rt for 1.5 h. The reaction was then quenched with aqueous 1 M HCl (100 mL) and stirred an additional 10 min. The mixture was washed with brine (100 mL), dried over Na₂SO₄ and concentrated *in vacuo*. The crude solid was recrystallized from a solution of 25% ethyl acetate in hexanes to give **176** (10.5 g, 97%) as a colourless solid. mp: 74-75 °C; ¹H NMR (500 MHz, CDCl₃): δ 7.41 (t, *J* = 4.5 Hz, 1H), 2.60 (t, *J* = 6.7 Hz, 2H), 2.43 (q, *J* = 5.3 Hz, 2H), 2.05 (quintet, *J* = 6.5 Hz, 2H); ¹³C NMR

(126 MHz, CDCl₃): δ 191.4, 151.4, 123.9, 38.4, 28.4, 22.7. These data match those in the literature.¹⁶³

6-Bromo-1,4-dioxaspiro[4.5]dec-6-ene (177)

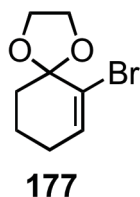

para-Toluenesulfonic acid (0.16 g, 0.82 mmol) was added to a solution of ketone **176** (2.87 g, 16.4 mmol) and ethylene glycol (1.83 mL, 32.8 mmol) in benzene (200 mL). The solution was heated under reflux over 14 h with azeotropic removal of water using a Dean-Stark apparatus filled with 4 Å molecular sieves. The solution was cooled to rt, and the acid was neutralized by addition of triethylamine (2 mL). The organic solution was washed with water (2 × 100 mL) and brine (100 mL), dried over MgSO₄, and concentrated *in vacuo*. The residue was purified by flash chromatography (33% ethyl acetate in hexanes) to provide **177** (3.08 g, 86%) as a colourless oil: ¹H NMR (500 MHz, CDCl₃): δ 6.32 (t, *J* = 4.1 Hz, 1H), 4.18-4.16 (m, 2H), 3.98-3.95 (m, 2H), 2.09-2.06 (m, 2H), 1.91-1.88 (m, 2H), 1.79-1.74 (m, 2H); ¹³C NMR (126 MHz, CDCl₃): δ 136.2, 124.7, 105.9, 65.9, 35.7, 27.6, 20.4. These data match those in the literature.¹⁶⁴

2-(Trimethylsilyl)cyclohex-2-en-1-one (178)

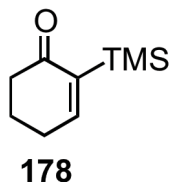

A solution of *n*-butyllithium (2.5 M in hexanes, 5.8 mL) was added dropwise over 10 min to a solution of ketal **177** (2.68 g, 12.2 mmol) in THF (40 mL) at -78 °C. A solution of chlorotrimethylsilane (2.93 mL, 23.2 mmol) in THF (10 mL) was then added to the mixture, which was stirred an additional 5 min at -78 °C before allowing the solution to attain rt. The reaction mixture was washed with water (20 mL), aqueous saturated sodium bicarbonate (20 mL), then brine (20 mL) before drying over MgSO_4 and concentrating *in vacuo*. The residue was purified by flash chromatography (10% ethyl acetate in hexanes) to provide **178** (1.45 g, 71%) as a colourless oil: ^1H NMR (500 MHz, CDCl_3): δ 7.06 (t, $J = 3.9$ Hz, 1H), 2.29-2.27 (m, 2H), 2.25-2.22 (m, 2H), 1.87 (quintet, $J = 6.5$ Hz, 2H), 0.01 (s, 9H); ^{13}C NMR (126 MHz, CDCl_3): δ 202.7, 158.4, 142.0, 38.8, 27.4, 23.0, -1.3. These data match those in the literature.¹⁴³

2-(Trimethylsilyl)cyclohex-1-en-1-yl trifluoromethanesulfonate (**148**)

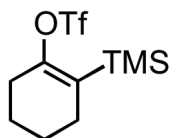

148

L-Selectride (1 M in THF, 9.0 mL) was added dropwise to a solution of α -silyl ketone **178** (1.45 g, 8.60 mmol) in THF (25 mL) at -78 °C. The reaction mixture was stirred at -78 °C for 30 min before adding in a solution of PhNTf₂ (3.23 g, 9.0 mmol) in THF (25 mL). The reaction mixture was then allowed to attain rt and it was stirred an additional 30 min. The mixture was diluted with pentane (100 mL) and washed with water (3×25 mL) and the combined aqueous washes were re-extracted with pentane (20 mL). The combined organic extracts were washed with aqueous 10% NaOH (2×25 mL), followed by brine (25 mL), then dried over MgSO₄ and concentrated *in vacuo*. The residue was purified by flash chromatography (2.5% triethylamine in pentane) to give **148** (1.58 g, 61%) as a colourless oil.* ¹H NMR (500 MHz, CDCl₃): δ 2.40-2.38 (m, 2H), 2.20-2.17 (m, 2H), 1.77-1.72 (m, 2H), 1.59-1.55 (m, 2H), 0.18 (s, 9H); ¹³C NMR (126 MHz, CDCl₃): δ 154.6, 128.1, 118.5 (q, $J = 320$ Hz), 28.57, 28.41, 23.2, 21.9, -1.2. These data match those in the literature.¹³⁹

* A yield of 96% was obtained when N-Selectride was used in lieu of L-Selectride.

(8aR*,8bS*,12bR*,12cS*)-1,2,3,4,5,6,7,8,9,10,11,12-Dodecahydro-8b,12b-butanobenzo[3',4']cyclobuta[1',2':3,4]cyclobuta[1,2-*e*]biphenylene (180)

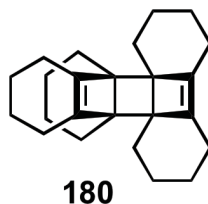

Method A: A solution of cyclohexyne precursor **148** (0.36 g, 1.2 mmol) in THF (10 mL) was added to a stirred suspension of CsF (0.55 g, 3.6 mmol) in THF (10 mL) at rt. The solution was heated to 60 °C and stirred for 24 h. The mixture was diluted with pentane (20 mL), then washed with water (20 mL). The aqueous phase was re-extracted with pentane (2 × 15 mL), and the combined organic phases were dried over MgSO₄, then concentrated *in vacuo*. The residue was purified by flash chromatography (pentane) to give **180** (16 mg, 17%) as a colourless solid.

Method B: Tetrabutylammonium fluoride (1 M in THF, 0.9 mL) was added to cyclohexyne precursor **148** (0.14 g, 0.45 mmol) at rt. The mixture was stirred for 5 min, then diluted with pentane (10 mL), and then washed with water (10 mL). The aqueous phase was re-extracted with pentane (2 × 10 mL), and the combined organic phases was dried over MgSO₄, then concentrated *in vacuo*. The residue was purified by flash chromatography (pentane) to give **180** (18 mg, 50%) as a colourless solid. mp: 128-132 °C; ¹H NMR (500 MHz, CDCl₃): δ 2.19 (dd, *J* = 13.9, 4.7 Hz, 2H), 1.87-1.82 (m, 4H), 1.71-1.68 (m, 4H), 1.65-1.56 (m, 12H), 1.39-1.33 (m, 2H), 1.30-1.25 (m, 2H), 1.23-1.18 (m, 2H), 1.17-1.12 (m, 2H), 1.02-0.93 (m,

2H); ^{13}C NMR (126 MHz, CDCl_3): δ 143.7, 137.4, 48.9, 47.7, 26.8, 24.5, 23.9, 23.5, 23.4, 23.3, 22.1, 21.3. These data match those in the literature.¹⁶⁵

(8aR*,8bS*,12bR*,12cS*)-1,2,3,4,5,6,7,8,9,10,11,12-Dodecahydro-8b,12b-butanobenzo[3',4']cyclobuta[1',2':3,4]cyclobuta[1,2-*e*]biphenylene (180), and (1R*,4S*)-1,4,5,6,7,8-hexahydro-1,4-epoxynaphthalene (184)

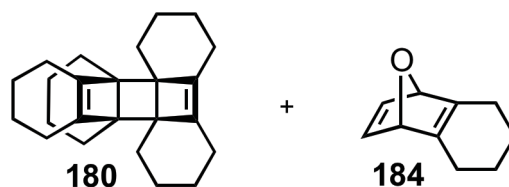

Method A: A solution of cyclohexyne precursor **148** (0.20 g, 0.66 mmol) and furan (0.14 mL, 1.98 mmol) in THF (8 mL) was added to a stirred suspension of CsF (0.30 g, 1.98 mmol) in THF (7 mL) at rt. The solution was then heated to 60 °C and stirred for 24 h. The reaction mixture was diluted with ether (20 mL), then washed with water (20 mL). The aqueous phase was re-extracted with ether (2 × 15 mL), and the combined organic phases was dried over MgSO_4 , and concentrated *in vacuo*. The residue was purified by flash chromatography (pentane to 10% ether in pentane) to give **180** (10 mg, 18%) as a colourless solid and **184** (30 mg, 31%) as a colourless oil.

Method B: Tetrabutylammonium fluoride (1 M in THF, 0.75 mL) was added to a solution of cyclohexyne precursor **148** (0.15g, 0.50 mmol) and furan (0.11 mL, 1.5 mmol) in THF (10 mL) at rt. The mixture was stirred for 15 min, then

was diluted with ether (20 mL), then washed with water (20 mL). The aqueous phase was re-extracted with ether (2×15 mL), and the combined organic phases was dried over MgSO_4 , then concentrated *in vacuo*. The residue was purified by flash chromatography (pentane to 10% ether in pentane) to give **180** (24 mg, 60%) as a colourless solid and **184** (15 mg, 20%) as a colourless oil.

Method C: Tetrabutylammonium fluoride (1 M in THF, 7.5 mL) was added dropwise to a solution of cyclohexyne precursor **148** (0.15g, 0.50 mmol) and furan (10 mL) at rt. The mixture was stirred an additional 15 min before removal of the solvents *in vacuo*. The residue was diluted with ether (20 mL), then washed with water (20 mL), then with brine (20 mL), and dried over MgSO_4 , and concentrated *in vacuo*. The residue was purified by flash chromatography (pentane to 10% ether in pentane) to give **180** (2 mg, 5%) as a colourless solid and **184** (53 mg, 72%) as a colourless oil. For **184**: ^1H NMR (500 MHz, CDCl_3): δ 7.07 (s, 2H), 5.13 (s, 2H), 2.38-2.33 (m, 2H), 1.86-1.81 (m, 2H), 1.69-1.63 (m, 2H), 1.49-1.42 (m, 2H); ^{13}C NMR (126 MHz, CDCl_3): δ 149.0, 143.8, 84.5, 24.2, 23.0; HRMS (ESI) calcd for $[\text{C}_{10}\text{H}_{12}\text{ONa}]^+$: 171.0780, found: 171.0778.

Buta-1,3-dien-2-yl acetate (**187**)

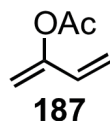

A solution of n-butyllithium (2.5 M in hexanes, 10 mL) was added dropwise to a solution of diisopropylamine (3.84 mL, 27.3 mmol) in THF (15 mL) at $-78\text{ }^{\circ}\text{C}$ and the resulting mixture was stirred for 5 min. A solution of methyl vinyl ketone (1.85 mL, 22.7 mmol) in THF (2.0 mL) was added dropwise to the lithium diisopropylamide (LDA) solution, and the solution was stirred for 15 min at $-78\text{ }^{\circ}\text{C}$. Acetic anhydride (2.79 mL, 29.5 mmol) was added slowly to the solution, then the mixture was allowed to slowly attain rt, and it was stirred for 15 h. The solution was diluted with pentane (20 mL), and then washed with aqueous saturated sodium bisulfate (20 mL), and brine (20 mL). The organic solution was dried over MgSO_4 and concentrated *in vacuo*. The residue was purified by flash chromatography (10% ether in pentane) to give **187** (0.84 g, 33%) as a colourless oil. ^1H NMR (500 MHz, CDCl_3): δ 6.25 (dd, $J = 17.2, 10.9$ Hz, 1H), 5.27 (d, $J = 17.2$ Hz, 1H), 5.16 (d, $J = 10.9$ Hz, 1H), 5.01 (s, 1H), 4.92 (s, 1H), 2.22 (s, 3H); ^{13}C NMR (126 MHz, CDCl_3): δ 168.8, 151.9, 131.0, 115.4, 106.3, 20.9. These data match those in the literature.¹⁶⁶

1,4,5,6,7,8-Hexahydronaphthalen-2-yl acetate (**188**)

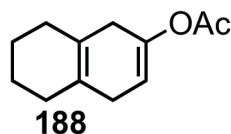

According to the procedure for **180** + **184**, method A: cyclohexyne precursor **148** (0.20 g, 0.66 mmol) and diene **187** (0.22 g, 1.98 mmol) in THF (8 mL) was added to CsF (0.30 g, 1.98 mmol) in THF (7 mL) to give **180** (11 mg, 19%) as a colourless solid and **188** (44 mg, 35%) as a colourless oil. For **188**: ^1H NMR (500 MHz, CDCl_3): δ 5.37 (br s, 1H), 2.69-2.64 (m, 4H), 2.12 (s, 3H), 1.87 (br s, 4H), 1.64-1.61 (m, 4H); ^{13}C NMR (126 MHz, CDCl_3): δ 169.7, 145.9, 125.1, 124.7, 111.7, 32.9, 32.1, 29.7, 29.3, 23.1, 22.9, 21.2; HRMS (ESI) calcd for $[\text{C}_{12}\text{H}_{16}\text{O}_2\text{Na}]^+$: 215.1043, found: 215.1038.

(1*R**,4*S**)-1,4,5,6,7,8-Hexahydro-1,4-ethanonaphthalene (**189**)

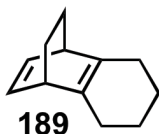

According to the procedure for **180** + **184**, method A: cyclohexyne precursor **148** (0.20 g, 0.66 mmol) and 1,3-cyclohexadiene (0.19 mL, 1.98 mmol) in THF (8 mL) was added to CsF (0.30 g, 1.98 mmol) in THF (7 mL) to give **180** (12 mg, 21%) as a colourless solid and **189** (21 mg, 20%) as a colourless oil. For **189**: ^1H NMR (500 MHz, CDCl_3): δ 6.31-6.30 (m, 2H), 3.23 (br s, 2H), 2.05 (br s,

4H), 1.56-1.51 (m, 4H), 1.29-1.22 (m, 4H); ^{13}C NMR (126 MHz, CDCl_3): δ 136.5, 134.6, 41.8, 27.0, 25.8, 23.5; HRMS (ESI) calcd for $[\text{C}_{12}\text{H}_{16}\text{Ag}]^+$: 267.0297, found: 267.0306. These data are consistent with, and an improvement on, of those in the literature.¹⁶⁷

6-Methylcyclohex-2-en-1-one (197)

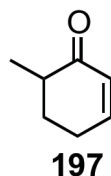

A solution of *n*-butyllithium (2.5 M in hexanes, 4.9 mL) was added dropwise to a solution of diisopropylamine (1.70 mL, 12.2 mmol) in THF (30 mL) at $-78\text{ }^\circ\text{C}$ and the resulting mixture was stirred for 5 min. A solution of cyclohex-2-en-1-one (1.00 mL, 10.2 mmol) in THF (60 mL) was added dropwise to the LDA solution, and the mixture was stirred for 30 min at rt before it was cooled to $-78\text{ }^\circ\text{C}$. Iodomethane (3.18 mL, 51.0 mmol) was added slowly to the solution. The mixture was allowed to slowly attain rt, and then it was stirred for 12 h. Water (100 mL) was added, and the mixture was extracted with ethyl acetate ($3 \times 50\text{ mL}$). The combined organic extracts were washed with brine (100 mL), dried over MgSO_4 and concentrated *in vacuo*. The residue was purified by flash chromatography (25% ether in pentane) to give **197** (0.84 g, 75%) as a colourless oil. ^1H NMR (500 MHz, CDCl_3): δ 6.93-6.90 (m, 1H), 5.98 (br d, $J = 10.0\text{ Hz}$, 1H), 2.42-2.37 (m, 3H), 2.08-2.05 (m, 1H), 1.77-1.70 (m, 1H), 1.14 (d, $J = 6.8\text{ Hz}$, 3H); ^{13}C NMR (126 MHz,

CDCl₃): δ 202.4, 149.7, 129.5, 41.8, 31.0, 25.6, 15.2. These data match those in the literature.¹⁵¹

6,6-Dimethylcyclohex-2-en-1-one (**199**)

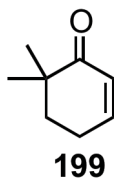

According to the procedure for **197**: *n*-butyllithium (2.5 M in hexanes, 1.5 mL), and diisopropylamine (0.46 mL, 3.3 mmol) in THF (10 mL) were reacted with ketone **197** (0.30 g, 2.7 mmol) in THF (20 mL). Iodomethane (0.68 mL, 11 mmol) was added to give **199** (0.16 g, 48%) as a colourless oil. ¹H NMR (500 MHz, CDCl₃): δ 6.83 (dt, *J* = 10.0, 4.0 Hz, 1H), 5.88 (dt, *J* = 10.0, 2.0 Hz, 1H), 2.34 (tdd, *J* = 6.0, 4.0, 2.0 Hz, 2H), 1.80 (t, *J* = 6.1 Hz, 2H), 1.08 (s, 6H); ¹³C NMR (126 MHz, CDCl₃): δ 202.4, 149.7, 129.5, 41.8, 31.0, 25.6, 15.2. These data match those in the literature.¹⁶⁸

2-Bromo-6-methylcyclohex-2-en-1-one (202)

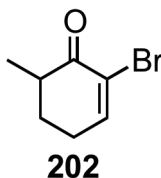

According to the procedure for **176**: bromine (0.26 mL, 5.0 mmol) in CH₂Cl₂ (15 mL) was added to a solution of ketone **197** (0.55 g, 5.0 mmol) in CH₂Cl₂ (15 mL). Triethylamine (1.2 mL, 8.5 mmol) was added to give, after flash chromatography (5% ether in pentane), **202** (0.60 g, 63%) as a colourless oil. ¹H NMR (500 MHz, CDCl₃): δ 7.28 (t, *J* = 4.5 Hz, 1H), 2.75-2.68 (m, 1H), 2.44-2.30 (m, 2H), 2.15-1.90 (m, 2H), 1.21 (d, *J* = 6.5 Hz, 3H); ¹³C NMR (126 MHz, CDCl₃): δ 194.3, 145.9, 131.7, 42.6, 30.5, 26.3, 15.3. These data match those in the literature.¹⁶⁹

2-Bromo-6,6-dimethylcyclohex-2-en-1-one (204)

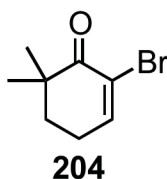

According to the procedure for **176**: bromine (0.26 mL, 5.0 mmol) in CH₂Cl₂ (15 mL) was added to a solution of ketone **199** (0.62 g, 5.0 mmol) in CH₂Cl₂ (15 mL). Triethylamine (1.2 mL, 8.5 mmol) was added to give, after flash chromatography (5% ether in pentane), **204** (0.68 g, 67%) as a colourless oil. ¹H

NMR (500 MHz, CDCl₃): δ 7.30 (t, *J* = 4.4 Hz, 1H), 2.45-2.42 (m, 2H), 1.88 (t, *J* = 6.0 Hz, 2H), 1.16 (s, 6H); ¹³C NMR (126 MHz, CDCl₃): δ 196.3, 149.4, 123.1, 43.1, 36.0, 25.7, 24.5. HRMS pending.

1,2-Bis(trimethylsilyloxy)ethane (**206**)

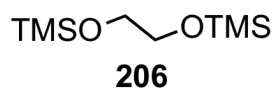

To a solution of ethylene glycol (1.7 mL, 30 mmol) in CH₂Cl₂ (150 mL) was added triethylamine (12 mL, 90 mmol) and chlorotrimethylsilane (9.5 mL, 75 mmol). The mixture was stirred at rt for 30 min, and then the precipitate was removed by suction filtration. The solid was washed with dichloromethane (3 × 20 mL) and the filtrate was concentrated *in vacuo* to give **206** (4.9 g, 79%) as a colourless oil. ¹H NMR (500 MHz, CDCl₃): δ 3.64 (s, 4H), 0.11 (s, 18H); ¹³C NMR (126 MHz, CDCl₃): δ 64.1, -0.3. These data match those in the literature.¹⁷⁰

6-Methyl-2-(trimethylsilyl)cyclohex-2-en-1-one (**207**)

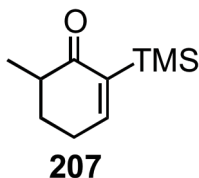

According to the procedure for **197**: *n*-butyllithium (2.5 M in hexanes, 4.8 mL), and diisopropylamine (1.70 mL, 12.2 mmol) in THF (30 mL) were reacted with ketone **178** (1.71 g, 10.2 mmol) in THF (60 mL). Iodomethane (3.18 mL, 51.0 mmol) was added to give **207** (1.48 g, 80%) as a colourless oil. ¹H NMR (500 MHz, CDCl₃): δ 7.09 (td, *J* = 3.9, 1.0 Hz, 1H), 2.42-2.38 (m, 2H), 2.37-2.34 (m, 1H), 2.07-2.01 (m, 1H), 1.74-1.66 (m, 1H), 1.11 (d, *J* = 6.8 Hz, 3H), 0.12 (s, 9H); ¹³C NMR (126 MHz, CDCl₃): δ 205.2, 157.3, 141.5, 41.9, 31.1, 27.5, 15.2, -1.2; HRMS pending.

6,6-Dimethyl-2-(trimethylsilyl)cyclohex-2-en-1-one (**208**)

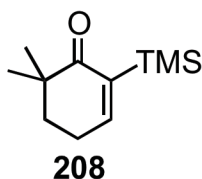

According to the procedure for **197**: *n*-butyllithium (2.5 M in hexanes, 4.6 mL), and diisopropylamine (1.37 mL, 9.74 mmol) in THF (20 mL) were reacted with ketone **207** (1.48 g, 8.12 mmol) in THF (40 mL). Iodomethane (1.66 mL, 32.5 mmol) was added to give **208** (1.20 g, 75%) as a colourless oil. ¹H NMR (500 MHz,

CDCl₃): δ 7.02 (t, J = 3.7 Hz, 1H), 2.39-2.36 (m, 2H), 1.80 (t, J = 6.1 Hz, 2H), 1.07 (s, 6H), 0.11 (s, 9H); HRMS pending.

2-Bromo-3-methylcyclohex-2-en-1-one (214), *meta*-cresol (215), and 4-bromo-3-methylphenol (216)

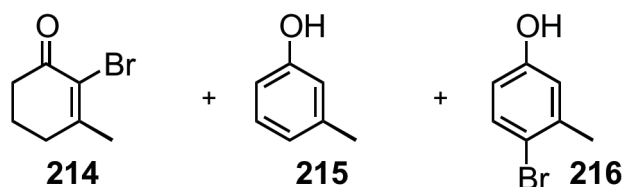

According to the procedure for **176**: bromine (2.67 mL, 50.0 mmol) in CH₂Cl₂ (130 mL) was added to a solution of 3-methylcyclohex-2-en-1-one (5.67 mL, 50.0 mmol) in CH₂Cl₂ (130 mL). Triethylamine (11.8 mL, 85.0 mmol) was added to give, after flash chromatography (25% ether in pentane), a mixture of **214** (0.66 g, 7%), **215** (1.46 g, 27%), and **216** (1.50 g, 16%), as colourless oils. For **214**: ¹H NMR (500 MHz, CDCl₃): δ 2.51 (t, J = 6.8 Hz, 2H), 2.47 (t, J = 6.1 Hz, 2H), 2.11 (s, 3H), 1.95 (quintet, J = 6.5 Hz, 2H); ¹³C NMR (126 MHz, CDCl₃): δ 190.9, 160.5, 122.7, 37.6, 34.1, 25.9, 21.8. These data match those in the literature.¹⁵⁴ For **215**: ¹H NMR (500 MHz, CDCl₃): δ 7.16 (t, J = 7.7 Hz, 1H), 6.79 (d, J = 7.5 Hz, 1H), 6.71-6.68 (m, 2H), 5.93 (br s, 1H), 2.33 (s, 3H); ¹³C NMR (126 MHz, CDCl₃): δ 154.9, 140.0, 129.5, 121.8, 116.2, 112.5, 21.4. These data match those in the literature.¹⁷¹ For **216**: ¹H NMR (500 MHz, CDCl₃): δ 7.37 (d, J = 8.6 Hz, 1H), 6.76 (d, J = 2.9 Hz, 1H), 6.59 (dd, J = 8.6, 2.9 Hz, 1H), 5.93 (br s, 1H), 2.35 (s, 3H); ¹³C

NMR (126 MHz, CDCl₃): δ 155.4, 139.2, 133.1, 118.0, 115.4, 114.7, 23.0. These data match those in the literature.¹⁷²

2-Bromo-3-methylcyclohex-2-en-1-one (214)

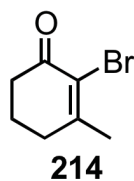

To a solution of 3-methylcyclohex-2-en-1-one (2.95 mL, 26.0 mmol) in CH₂Cl₂ (250 mL) was added tetrabutylammonium tribromide (25 g, 52 mmol) and potassium carbonate (21.6 g, 156 mmol) at 0 °C. The reaction mixture was allowed to warm to rt and it was stirred for 48 h. The solids were filtered from the solution and washed with CH₂Cl₂ (3 × 50 mL), and the filtrate was concentrated *in vacuo*. The residue was purified by flash chromatography (25% ether in pentane) to give **214** (3.67 g, 75%).

6-Bromo-7-methyl-1,4-dioxaspiro[4.5]dec-6-ene (217)

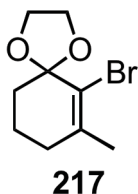

According to the procedure for **177**: *para*-toluenesulfonic acid (0.63 g, 0.33 mmol) was added to **214** (1.26 g, 6.67 mmol) and ethylene glycol (2.23 mL, 40.0 mmol) in benzene (200 mL) to give, after flash chromatography (10% ether in pentane), **217** (3.08 g, 75%) as a colourless solid. mp: 58-60 °C; ¹H NMR (500 MHz, CDCl₃): δ 4.23-4.17 (m, 2H), 4.00-3.94 (m, 2H), 2.14 (t, *J* = 6.1 Hz, 2H), 1.90-1.87 (m, 5H), 1.78-1.73 (m, 2H); ¹³C NMR (126 MHz, CDCl₃): δ 141.2, 121.9, 106.9, 65.9, 35.6, 33.3, 24.0, 20.4. These data match those in the literature.¹⁴³

3-Methyl-2-(trimethylsilyl)cyclohex-2-en-1-one (218)

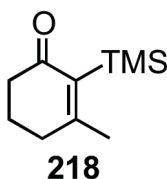

According to the procedure for **178**: *n*-butyllithium (2.5 M in hexanes, 7.3 mL) was added to **217** (3.52 g, 15.1 mmol) in THF (50 mL). Chlorotrimethylsilane (3.62 mL, 28.7 mmol) in THF (10 mL) was added to give, after flash chromatography (10% ether in pentane), **218** (2.00 g, 73%) as a colourless oil. ¹H NMR (500 MHz, CDCl₃): δ 2.28 (t, *J* = 6.6 Hz, 4H), 2.01 (s, 3H), 1.89 (quintet, *J* =

6.5 Hz, 2H), 0.20 (s, 9H); ^{13}C NMR (126 MHz, CDCl_3): δ 203.2, 169.5, 136.7, 38.0, 34.8, 24.9, 22.3, 1.8. These data match those in the literature.¹⁴³

3-Methyl-2-(trimethylsilyl)cyclohex-1-en-1-yl trifluoromethanesulfonate (**219**)

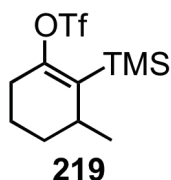

According to the procedure for **148**: L-Selectride (1 M in THF, 1.42 mL) was added to **218** (246 mg, 1.35 mmol) in THF (10 mL). PhNTf_2 (530 mg, 1.48 mmol) in THF (10 mL) was added to give, after flash chromatography (2.5% triethylamine in pentane), **219** (121 mg, 28%) as a colourless oil.* ^1H NMR (500 MHz, CDCl_3): δ 2.56-2.53 (m, $J = 1.7$ Hz, 1H), 2.42-2.36 (m, 2H), 1.88-1.84 (m, $J = 3.2$ Hz, 1H), 1.75-1.72 (m, $J = 3.4$ Hz, 1H), 1.64-1.57 (m, $J = 3.5$ Hz, 1H), 1.45-1.41 (m, 1H), 1.07 (d, $J = 7.0$ Hz, 3H), 0.22 (s, 9H); ^{13}C NMR (126 MHz, CDCl_3): δ 155.7, 132.9, 118.5 (q, $J = 320$ Hz), 32.5, 29.2, 28.4, 21.3, 19.0, -0.4; HRMS pending.

* A yield of 48% was achieved when N-Selectride was used in lieu of L-Selectride.

3,3-Dimethylcyclohex-1-en-1-yl trifluoromethanesulfonate (**223**)

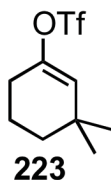

To a stirred suspension of copper (I) iodide (348 mg, 1.83 mmol) in diethyl ether (2 mL) at 0 °C was added methyllithium (1.6 M, 2.29 mL) dropwise. The solution was stirred for 30 min before cooling to -78 °C. A solution of 3-methylcyclohex-2-en-1-one (0.208 mL, 1.83 mmol) in THF (4 mL) was added dropwise to the Me₂CuLi solution, and the solution was stirred for 1 h at -78 °C before it was warmed to 0 °C for an additional 1 h. A solution of PhNTf₂ (720 mg, 2.02 mmol) in THF (4 mL) was added to the mixture, which was stirred for 2 h at 0 °C. The mixture was diluted with pentane (10 mL) and washed with aqueous saturated ammonium chloride (15 mL). The phases were separated and the organic layer was washed with brine (15 mL), dried over MgSO₄ and concentrated *in vacuo*. The residue was purified by flash chromatography (pentane) to give **223** as a colourless oil. ¹H NMR (500 MHz, CDCl₃): δ 5.50 (br s, 1H), 2.28-2.25 (m, 2H), 1.79-1.74 (m, 2H), 1.43-1.40 (m, 2H), 1.05 (s, 6H); ¹³C NMR (126 MHz, CDCl₃): δ 148.3, 128.1, 45.8, 35.7, 32.9, 29.2, 27.4, 19.6. These data match those in the literature.¹⁷³

(8a*R**,8b*S**,12b*R**,12c*S**)-1,5,12,16-Tetramethyl-1,2,3,4,5,6,7,8,9,10,11,12-dodecahydro-8b,12b-butanobenzo[3',4']cyclobuta[1',2':3,4]cyclobuta[1,2-*e*]biphenylene (**224**), and (1*R**,4*S**)-5-methyl-1,4,5,6,7,8-hexahydro-1,4-epoxynaphthalene (**225**)

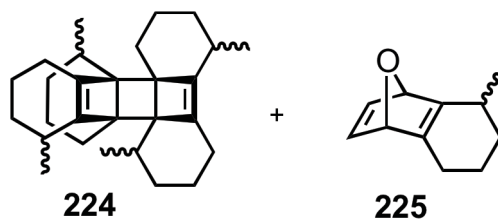

According to the procedure for **180** + **184**, method B: tetrabutylammonium fluoride (1 M in THF, 3.84 mL) was added to a solution of cyclohexyne precursor **219** (607 mg, 1.92 mmol) and furan (4.2 mL, 57 mmol) in THF (60 mL) to give a complex mixture of diastereomers **224** (73 mg, 40%) as a colourless oil and a 2:1 mixture of diastereomers **225** (24 mg, 8%) as a colourless oil.* For **224**: ¹H NMR (500 MHz, CDCl₃): δ 2.32-0.90 (complex m); ¹³C NMR (126 MHz, CDCl₃): δ 139.4, 138.17, 138.14, 133.46, 133.42, 126.7, 120.5, 115.2, complex mixture of signals between 33.0-18.7. HRMS (ESI) calcd for [C₂₈H₄₀Ag]⁺: 483.2175, found: 483.2162. For major diastereomer of **225**: ¹H NMR (500 MHz, CDCl₃): δ 7.07 (s, 1H), 7.06 (s, 1H), 5.25 (s, 1H), 5.13 (s, 1H), 2.60 (br s, 1H), 2.39-1.61 (m, 6H), 0.84 (d, *J* = 7.1 Hz, 3H); ¹³C NMR (126 MHz, CDCl₃): δ 152.3, 149.3, 144.2, 143.7, 84.8, 83.9, 32.1, 28.7, 24.5, 21.4, 16.8. For minor diastereomer of **225**: ¹H NMR (500 MHz, CDCl₃): δ 7.03 (s, 1H), 7.02 (s, 1H), 5.25 (s, 1H), 5.14 (s, 1H), 2.39-1.61 (m, 7H), 1.14 (d, *J* = 7.0 Hz, 3H); ¹³C NMR (126 MHz, CDCl₃): δ 153.7,

* NMR sample was contaminated with 3-methylcyclohexan-1-one.

148.5, 144.3, 143.6, 84.6, 82.6, 31.8, 30.0, 24.3, 21.8, 19.8. HRMS (ESI) calcd for $[\text{C}_{11}\text{H}_{14}\text{ONa}]^+$: 185.0937, found: 185.0937.

2-Bromocyclohex-1-en-1-yl trifluoromethanesulfonate (**233**)

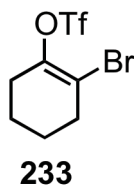

According to the procedure for **148**: L-Selectride (1 M in THF, 6.98 mL) was added to a solution of α -bromo ketone **176** (1.16 g, 6.65 mmol) in THF (50 mL). PhNTf_2 (2.49 g, 6.98 mmol) in THF (50 mL) was added to give, after flash chromatography (2.5% triethylamine and 5% ether in pentane), **233** (1.59 g, 78%) as a colourless oil. ^1H NMR (500 MHz, CDCl_3): δ 2.62-2.60 (m, 2H), 2.42-2.40 (m, 2H), 1.84-1.82 (m, 2H), 1.75-1.73 (m, 2H); ^{13}C NMR (126 MHz, CDCl_3): δ 145.5, 122.8, 118.4 (q, $J = 320$ Hz), 29.5, 28.2, 23.4, 22.4. These data match those in the literature.¹⁷⁴

1,2,3,4,5,6,7,8,9,10,11,12-Dodecahydrotriphenylene (179), and (8aR*,8bS*,12bR*,12cS*)-1,2,3,4,5,6,7,8,9,10,11,12-dodecahydro-8b,12b-butanobenzo-[3',4']cyclobuta[1',2':3,4]cyclobuta[1,2-*e*]biphenylene (180)

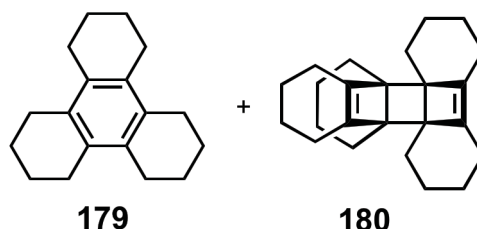

To a solution of cyclohexyne precursor **233** (0.46 g, 1.2 mmol) and 2,3-dimethylbutadiene (0.41 mL, 3.6 mmol) in THF (15 mL) was added *n*-butyllithium (2.5 M, 0.56 mL) at $-78\text{ }^{\circ}\text{C}$. The mixture was allowed to attain rt over 1 h. The mixture was diluted with pentane (15 mL), then it was washed with aqueous saturated ammonium chloride (15 mL) and brine (15 mL), dried over MgSO_4 and concentrated *in vacuo*. The residue was purified by flash chromatography (pentane) to give **179** (1 mg, 1%) and **180** (77 mg, 80%).* For **179**: ^1H NMR (500 MHz, CDCl_3): δ 2.61 (br s, 12 H), 1.81 (br 2, 12 H); ^{13}C NMR (126 MHz, CDCl_3): δ 132.8, 27.0, 23.2. These data match those in the literature.¹⁷⁵

* When the reaction was done with **236** in lieu of **233**, a 22% yield of **179** and 55% yield of **180** was obtained.

2-Iodocyclohex-2-en-1-one (235)

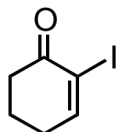

235

To a solution of cyclohex-2-en-1-one (1.93 mL, 20.0 mmol) in a 1:1 mixture of THF:H₂O (100 mL) was added potassium carbonate (3.31 g, 24.0 mmol), then iodine (7.6 g, 30.0 mmol) and DMAP (0.49 g, 4.0 mmol). The mixture was stirred at rt for 3 h, and it was diluted with ethyl acetate (100 mL), washed with aqueous saturated sodium thiosulfate (100 mL), 0.1 M HCl (100 mL), and then with brine (100 mL). The organic phase was dried over MgSO₄ and concentrated *in vacuo*. The residue was crystallized from 25% ethyl acetate in hexanes to give **235** (4.05 g, 91%) as a colourless solid. mp: 47-49 °C; ¹H NMR (500 MHz, CDCl₃): δ 7.75 (t, *J* = 4.3 Hz, 1H), 2.83-2.54 (m, 2H), 2.44 (dt, *J* = 5.9, 4.5 Hz, 2H), 2.11-2.08 (m, 2H); ¹³C NMR (126 MHz, CDCl₃) δ 192.2, 159.4, 103.9, 37.2, 29.8, 22.8. These data match those in the literature.¹⁶³

2-Iodocyclohex-1-en-1-yl trifluoromethanesulfonate (236)

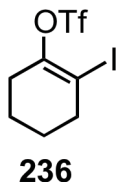

According to the procedure for **148**: L-Selectride (1 M in THF, 1.20 mL) was added to a solution of α -iodo ketone **235** (245 mg, 1.1 mmol) in THF (10 mL). PhNTf₂ (394 mg, 1.1 mmol) in THF (10 mL) was added to give, after flash chromatography (2.5% triethylamine and 5% ether in pentane), **236** (128 mg, 33%) as a colourless oil. ¹H NMR (500 MHz, CDCl₃): δ 2.72-2.69 (m, 2H), 2.48-2.45 (m, 2H), 1.88-1.83 (m, 2H), 1.71-1.66 (m, 2H); ¹³C NMR (126 MHz, CDCl₃): δ 150.2, 118.6 (q, $J = 320$ Hz), 90.9, 39.1, 29.3, 24.4, 22.6. HRMS pending.

2-Chlorocyclohex-2-en-1-one (237)

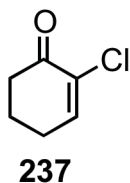

To a suspension of oxone (18.5 g, 30.0 mmol) in CH₂Cl₂ (100 mL) was added cyclohex-2-en-1-one (2.45 mL, 25.0 mmol), followed by 2 M HCl (27.5 mL). The mixture was stirred at rt for 2 h until the yellowish green colour disappeared. Triethylamine (20 mL) was added slowly to the mixture, which was stirred an additional 12 h. The mixture was diluted with ethyl acetate (100 mL) and washed

with water (3×100 mL), aqueous saturated sodium bicarbonate (2×100 mL), and brine (100 mL) before being dried over MgSO_4 and concentrated *in vacuo*. The residue was purified by flash chromatography (20% ether in pentane) to give **237** as a colourless solid. mp: 67-72 °C; ^1H NMR (500 MHz, CDCl_3): δ 7.15 (t, $J = 4.5$ Hz, 1H), 2.61 (dd, $J = 6.4, 5.9$ Hz, 2H), 2.49 (td, $J = 5.9, 4.5$ Hz, 2H), 2.11-2.07 (m, 2H); ^{13}C NMR (126 MHz, CDCl_3): δ 191.3, 146.5, 132.2, 38.4, 27.0, 22.5. These data match those in the literature.¹⁷⁶

2-Chlorocyclohex-1-en-1-yl trifluoromethanesulfonate (**238**)

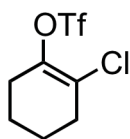

238

According to the procedure for **148**: L-Selectride (1 M in THF, 12.1 mL) was added to a solution of α -chloro ketone **237** (1.50 g, 11.5 mmol) in THF (100 mL). PhNTf_2 (4.10 g, 11.5 mmol) in THF (100 mL) was added to give, after flash chromatography (2.5% triethylamine and 5% ether in pentane), **238** (1.58 g, 52%) as a colourless oil. ^1H NMR (500 MHz, CDCl_3): δ 2.48 (tt, $J = 5.9, 2.8$ Hz, 1H), 2.42 (tt, $J = 5.9, 2.8$ Hz, 1H), 1.83-1.73 (m, 2H); ^{13}C NMR (126 MHz, CDCl_3): δ 143.6, 125.5, 118.5 (q, $J = 320$ Hz), 32.7, 28.6, 22.71, 22.56; HRMS pending.

Chapter 5 – Conclusions and Future Directions

Although a propellane may not have been synthesized using geminal acylation methods, the techniques and skills developed working on that project helped me along the way. A series of ketodiester with different ester moieties and of different carbon lengths were prepared, but geminal acylation was unsuccessful when the carbonyl was sterically congested by an α -methyl group. A geminal acylation reaction was attempted using an unmethylated derivative on a small scale, but no product of geminal acylation was observed.

Future efforts in this domain would be to make further attempts at the geminal acylation using the unmethylated derivative in the hope that varying the conditions might be met with success. For instance, reverting to the two-step procedure might allow the test of different acid regimes for the pinacol rearrangement. The rearrangement in the case of substrates with α -halogen substituents would not work until Amberlyst-15 was employed.²³ It is possible that the diester moiety also makes the reaction difficult, and thus another approach might be to change the ester functionalities to something less reactive and then to reconvert them into esters after the geminal acylation step has occurred (Scheme 70). For example, a dibromo-substituted ketone, such as **242**, could undergo geminal acylation with **2** to give **243**. The conversion of **243** to an ester would begin with the formation of a Grignard reagent by the addition of magnesium,

which could then react with diethyl carbonate to generate, after deprotecting the ketal, **73**.

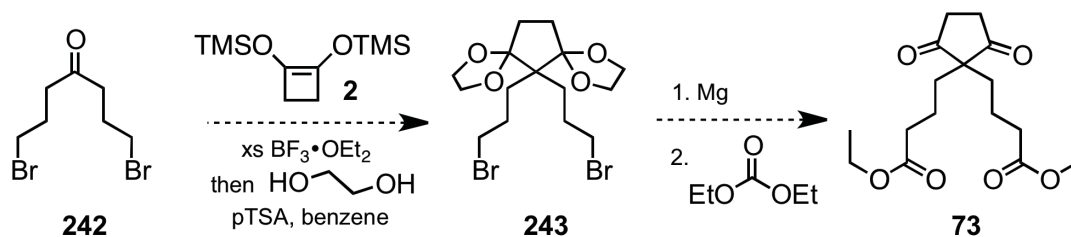

Scheme 70. Alternative method for generating 73.

A series of bicyclic compounds were prepared from a tandem Nazarov cyclization / (4+3) cycloaddition of AVKs with oxygen-substituted dienes. With one extreme exception, the oxygen-substituted dienes intercepted the Nazarov reactions exclusively by (4+3) cycloaddition, in contrast with all-carbon dienes. The process had very high facial selectivity, high regioselectivity, and modest to high diastereoselectivity depending on the substitution of both the oxyallyl cation of the AVK and the diene. These experimental results, in conjunction with computational studies that are currently underway, will provide valuable information regarding the mechanism of such (4+3) cycloadditions. Already, we are reasonably sure that the cycloadditions are concerted, which is in contrast with a number of studies that have hypothesized that the reaction is stepwise. The yields were nevertheless disappointing because the oxygen-bearing dienes were not stable to the reaction conditions. A thorough survey of Lewis acids might be worthwhile with the aim of finding a Lewis acid that can mediate the Nazarov reaction but not destroy the dienes.

Related work on the interrupted Nazarov reaction is exploring interception by five-membered heteroatomic aromatics, particularly thiophenes and furans. The products of these reactions could arise from mono-addition (Friedel-Crafts chemistry) or bis-addition, i.e., (3+2) or (4+3) cycloadditions. Depending on the substituents and their positions on the heteroaromatics, different trapping patterns might be observed. Preliminary studies are showing that thiophenes trap exclusively by mono-addition at position *a* on the oxyallyl cation of **80**, but thiazole is destroyed by the Lewis acid before the AVK can even cyclize. Furan has been known to intercept photochemical Nazarov reactions,¹⁷⁷ so photochemical reactions with AVKs might be attempted.

Progress has been made in the study of cyclohexyne and its Diels-Alder reactivity. These reactions often formed mainly a tetramer byproduct **180** unless the diene was used in large excess. Current work was to make this process more effective in order to suppress the formation of the tetramer. Future work to this end would be to build a library of compounds with fused cyclohexene moieties and look for trends in selectivity and reactivity and to discover what steric or electronic influences could have on regioselectivity and even facial selectivity in cycloaddition reactions.

Other future work would include forming the trisubstituted cyclohexyne **195**. The α -bromination of isophorone **201** using Br₂ and NEt₃ was unsuccessful in forming **243**, but tetrabutylammonium tribromide should improve the yield (Scheme 71). The remaining steps to generate the cyclohexyne precursor **200** will likely mirror the reactions used to form its unsubstituted analog, firstly, by

converting **244** to its ethylene glycol ketal **245**, then the installation of the trimethylsilyl group to form **246**, and finally, the 1,4-reduction and trapping of the resulting enolate to generate **200**. This methodology could also be extended to form the chiral cyclohexyne **247** from (S)-(-)-verbenone **248**.

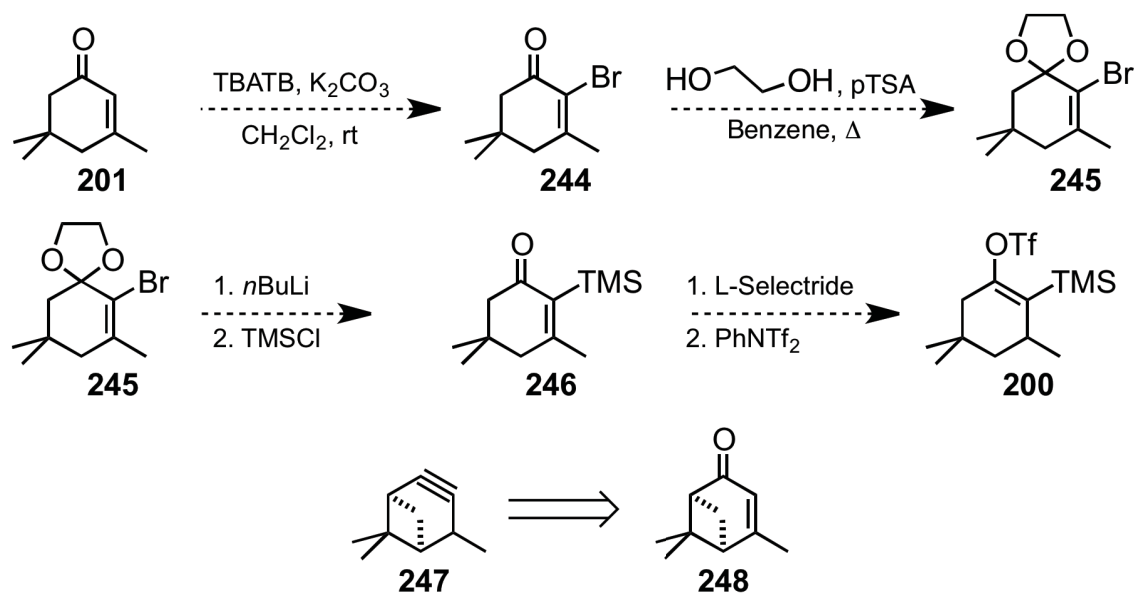

Scheme 71. Proposed route to forming trisubstituted cyclohexyne precursor **200 and the retrosynthesis of a chiral cyclohexyne.**

Future work might involve studying substituted cyclohexynes with various substituents to examine how steric and electronic effects play a factor in reactivity and selectivity. Adding functionality to the cyclohexyne moiety would also help cut down steps in natural product synthesis and perhaps making cyclohexyne a more powerful tool that could rival the popularity of benzyne.

References

- (1) Clayden, J.; Greeves, N.; Warren, S.; Wothers, P. *Organic Chemistry*, Oxford University Press Inc.: New York, 2001.
- (2) Wöhler, F. *Ann. Phys.* **1828**, 88, 253-256 as quoted by Nicolaou, K. C.; Sorensen, E. J. *Classics in Total Synthesis. Targets, Strategies, Methods*. VHC: Weinheim, 1996.
- (3) Nicolaou, K. C.; Sorensen, E. J. *Classics in Total Synthesis. Targets, Strategies, Methods*, VCH: Weinheim, 1996.
- (4) Pihko, A. J.; Koskinen, A. M. P. *Tetrahedron* **2005**, 61, 8769-8807.
- (5) Altman, J.; Babad, E.; Itzchaki, J.; Ginsburg, D. *Tetrahedron* **1966**, 279-304.
- (6) Nakanishi, W.; West, F. G. *Curr. Opin. Drug Discovery Dev.* **2009**, 12, 732-751.
- (7) Gampe, C. M.; Carreira, E. M. *Angew. Chem. Int. Ed.* **2012**, 51, 3766-3778.
- (8) Nakamura, E.; Kuwajima, I. *J. Am. Chem. Soc.* **1977**, 99, 961-963.
- (9) Ellison, R. A. *Synthesis* **1973**, 397-412.
- (10) Nakamura, E.; Hashimoto, K.; Kuwajima, I. *J. Org. Chem.* **1977**, 42, 4166-4167.
- (11) Shimada, J.; Hashimoto, K.; Kim, B. H.; Nakamura, E.; Kuwajima, I. *J. Am. Chem. Soc.* **1984**, 106, 1759-1773.
- (12) Wu, Y.-J.; Burnell, D. J. *Tetrahedron Lett.* **1988**, 29, 4369-4372.
- (13) Jenkins, T. J.; Burnell, D. J. *J. Org. Chem.* **1994**, 59, 1485-1491.
- (14) Martinez, R. A.; Rao, P. N.; Kim, H. K. *Synth. Commun.* **1989**, 19, 373-377.
- (15) Bloomfield, J. J. *Tetrahedron Lett.* **1968**, 5, 587-590.
- (16) Bloomfield, J. J.; Nelke, J. M. *Org. Synth.* **1977**, 57, 1-6.
- (17) Wu, Y.-J.; Burnell, D. J. *Tetrahedron Lett.* **1989**, 30, 1021-1024.
- (18) Pattenden, G.; Teague, S. *Tetrahedron Lett.* **1982**, 23, 1403-1404.

- (19) Crane, S. N.; Jenkins, T. J.; Burnell, D. J. *J. Org. Chem.* **1997**, *62*, 8722-8729.
- (20) Crane, S. N.; Burnell, D. J. *J. Org. Chem.* **1998**, *63*, 1352-1355.
- (21) Crane, S. N.; Burnell, D. J. *J. Org. Chem.* **1998**, *63*, 5708-5710.
- (22) Gao, F.; Burnell, D. J. *J. Org. Chem.* **2006**, *71*, 356-359.
- (23) Pottie, I. R.; Crane, S. N.; Gosse, A. L.; Miller, D. O.; Burnell, D. J. *Can. J. Chem.* **2010**, *88*, 1118-1124.
- (24) Bach, R. D.; Klix, R. C. *Tetrahedron Lett.* **1986**, *27*, 1983-1986.
- (25) Bach, R. D.; Klix, R. C. *J. Org. Chem.* **1986**, *51*, 749-752.
- (26) Evans, J. C.; Klix, R. C.; Bach, R. D. *J. Org. Chem.* **1988**, *53*, 5519-5527.
- (27) Wu, Y.-J.; Strickland, D. W.; Jenkins, T. J.; Liu, P.-Y.; Burnell, D. J. *Can. J. Chem.* **1993**, *71*, 1311-1318.
- (28) Maulide, N.; Markó, I. E. *Org. Lett.* **2007**, *9*, 3757-3760.
- (29) Armoush, N.; Syal, P.; Becker, D. P. *Synth. Commun.* **2008**, *38*, 1679-1687.
- (30) Solorzano, C.; Antonietti, F.; Duranti, A.; Tontini, A.; Rivara, S.; Lodola, A.; Vacondio, F.; Tarzia, G.; Piomelli, D.; Mor, M. *J. Med. Chem.* **2010**, *53*, 5770-5781.
- (31) Yu, W.; Williams, L.; Camp, V. M.; Olson, J. J.; Goodman, M. M. *Bioorg. Med. Chem. Lett.* **2010**, *20*, 2140-2143.
- (32) Zhou, Q.; Snider, B. B. *Org. Lett.* **2011**, *13*, 526-529.
- (33) Moulins, J. R.; Hughes, J. A.; Doyle, L. E.; Cameron, T. S.; Burnell, D. J. *Eur. J. Org. Chem.* **2015**, 1325-1332.
- (34) Anderson, W. K.; Lee, G. E. *J. Org. Chem.* **1980**, *45*, 501-506.
- (35) Anderson, W. K.; Lee, G. E. *Synth. Commun.* **1980**, *10*, 351-354.
- (36) Sisko, J.; Balog, A.; Curran, D. P. *J. Org. Chem.* **1992**, *57*, 4341-4342.
- (37) Balog, A.; Curran, D. P. *J. Org. Chem.* **1995**, *60*, 337-344.

- (38) Balog, A.; Geib, S. J.; Curran, D. P. *J. Org. Chem.* **1995**, *60*, 345-352.
- (39) Gao, F.; Burnell, D. J. *Tetrahedron Lett.* **2007**, *48*, 8185-8188.
- (40) Oppolzer, W.; Wylie, R. D. *Helv. Chim. Acta* **1980**, *63*, 1198-1200.
- (41) Burnell, D. J.; Wu, Y.-J. *Can. J. Chem.* **1990**, *68*, 804-811.
- (42) Wu, Y.-J.; Zhu, Y.-Y.; Burnell, D. J. *J. Org. Chem.* **1994**, *59*, 104-110.
- (43) Chavan, S. P.; Kharul, R. K.; Kale, R. R.; Khobragade, D. A. *Tetrahedron* **2003**, *59*, 2737-2741.
- (44) Pandey, R. C.; Toussaint, M. W.; Stroshane, R. M.; Kalita, C. C.; Aszalos, A. A.; Garretson, A. L.; Wei, T. T.; Byrne, K. M.; Geoghegan, R. F. J.; White, R. J. *J. Antibiot.* **1981**, *34*, 1389-1401.
- (45) Parker, K. A.; Koziski, K. A.; Breault, G. *Tetrahedron Lett.* **1985**, *26*, 2181-2182.
- (46) Parker, K. A.; Breault, G. A. *Tetrahedron Lett.* **1986**, *27*, 3835-3838.
- (47) Wendt, J. A.; Gauvreau, P. J.; Bach, R. D. *J. Am. Chem. Soc.* **1994**, *116*, 9921-9926.
- (48) Saint-Jalmes, L.; Lila, C.; Xu, J. Z.; Moreau, L.; Pfeiffer, B.; Eck, G.; Pelsez, L.; Rolando, C.; Julia, M. *Bull. Soc. Chim. Fr.* **1993**, *130*, 447-449.
- (49) Morrison, C. F.; Stamp, C. T. M.; Burnell, D. J. *Tetrahedron Lett.* **2009**, *50*, 7021-7023.
- (50) Kanada, R. M.; Taniguchi, T.; Ogasawara, K. *Chem. Commun.* **1998**, 1755-1756.
- (51) Thornton, P. D.; Burnell, D. J. *Org. Lett.* **2006**, *8*, 3195-3198.
- (52) Thornton, P. D.; Cameron, T. S.; Burnell, D. J. *Org. Biomol. Chem.* **2011**, *9*, 3447-3456.
- (53) Elliott, C. E.; Miller, D. O.; Burnell, D. J. *J. Chem. Soc., Perkin Trans. I* **2002**, 217-226.
- (54) Lin, X.; Kavash, R. W.; Mariano, P. S. *J. Org. Chem.* **1996**, *61*, 7335-7347.
- (55) Burnell, D. J.; Wu, Y.-J. *Can. J. Chem.* **1989**, *67*, 816-819.

- (56) Zalkow, L. H.; Harris III, R. N.; Van Derveer, D. *J. Chem. Soc., Chem. Commun.* **1978**, 420-421.
- (57) Blanchard, A. N.; Burnell, D. J. *Tetrahedron Lett.* **2001**, 42, 4779-4781.
- (58) Reingold, I. D.; Drake, J. *Tetrahedron Lett.* **1989**, 30, 1921-1922.
- (59) Yamago, S.; Nakamura, E. *J. Chem. Soc., Chem. Commun.* **1988**, 1112-1113.
- (60) Yamago, S.; Nakamura, E. *Tetrahedron* **1989**, 45, 3081-3088.
- (61) Kuwajima, I.; Azegami, I. *Tetrahedron Lett.* **1979**, 25, 2369-2372.
- (62) Nakamura, E.; Kuwajima, I. *Org. Synth.* **1987**, 65, 17-22.
- (63) Daignault, R. A.; Eliel, E. L. *Org. Synth.* **1967**, 47, 37-39.
- (64) Corey, E. J.; Venkateswarlu, A. *J. Am. Chem. Soc.* **1972**, 94, 6190-6191.
- (65) Kawata, A.; Takata, K.; Kuninobu, Y.; Takai, K. *Angew. Chem. Int. Ed.* **2007**, 46, 7793-7795.
- (66) Schraml, J.; Šraga, J.; Hrnčiar, P. *Coll. Czech. Chem. Commun.* **1983**, 48, 2937-2943.
- (67) Bisel, P.; Breitling, E.; Frahm, A. W. *Eur. J. Org. Chem.* **1998**, 729-733.
- (68) Jarkas, N.; Voll, R. J.; Williams, L.; Camp, V. M.; Goodman, M. M. *J. Med. Chem.* **2010**, 53, 6603-6607.
- (69) Fraenkel, G.; Gallucci, J.; Rosenzweig, H. S. *J. Org. Chem.* **1989**, 54, 677-681.
- (70) Ameer, F.; Giles, R. G. F.; Green, I. R.; Nagabhushana, K. S. *Synth. Commun.* **2002**, 32, 369-380.
- (71) Schick, H.; Schwarz, S.; Eberhardt, U. *J. Prakt. Chem.* **1977**, 319, 213-218.
- (72) Konno, M.; Nakae, T.; Sakuyama, S.; Imaki, K.; Nakai, H.; Hamanaka, N. *Synlett* **1997**, 1472-1474.
- (73) Yasui, K.; Fugami, K.; Tanaka, S.; Tamaru, Y. *J. Org. Chem.* **1995**, 60, 1365-1380.

- (74) Jackson, R. F. W.; Turner, D.; Block, M. H. *J. Chem. Soc., Perkin Trans. I* **1997**, 865-870.
- (75) Nazarov, I. N.; Zaretskaya, I. I. *Izv. Akad. Nauk. SSSR, Ser. Khim.* **1941**, 211-224.
- (76) Tius, M. A. *Eur. J. Org. Chem.* **2005**, 2193-2206.
- (77) Pellissier, H. *Tetrahedron* **2005**, *61*, 6479-6517.
- (78) Frontier, A. J.; Collison, C. *Tetrahedron* **2005**, *61*, 7577-7606.
- (79) Kim, S. H.; Cha, J. K. *Synthesis* **2000**, 2113-2116.
- (80) Liang, G. X.; Gradl, S. N.; Trauner, D. *Org. Lett.* **2003**, *5*, 4931-4934.
- (81) Janka, M.; He, W.; Frontier, A. J.; Eisenberg, R. *J. Am. Chem. Soc.* **2004**, *126*, 6864-6865.
- (82) Janka, M.; He, W.; Frontier, A. J.; Flaschenreim, C.; Eisenberg, R. *Tetrahedron* **2005**, *61*, 6193-6206.
- (83) Grant, T. N.; Rieder, C. J.; West, F. G. *Chem. Commun.* **2009**, 5676-5688.
- (84) Giese, S.; Kastrup, L.; Stiens, D.; West, F. G. *Angew. Chem. Int. Ed.* **2000**, *39*, 1970-1973.
- (85) Mahmoud, B.; West, F. G. *Tetrahedron Lett.* **2007**, *48*, 5091-5094.
- (86) Wang, Y.; Arif, A. M.; West, F. G. *J. Am. Chem. Soc.* **1999**, *121*, 876-877.
- (87) Wang, Y.; Schill, B. D.; Arif, A. M.; West, F. G. *Org. Lett.* **2003**, *5*, 2747-2750.
- (88) Rieder, C. J.; Fradette, R. J.; West, F. G. *Chem. Commun.* **2008**, 1572-1574.
- (89) Rieder, C. J.; Fradette, R. J.; West, F. G. *Heterocycles* **2010**, *80*, 1413-1427.
- (90) White, T. D.; West, F. G. *Tetrahedron Lett.* **2005**, *46*, 5629-5632.
- (91) Giese, S.; West, F. G. *Tetrahedron* **2000**, *56*, 10221-10228.
- (92) Hashmi, A. S. K.; Bats, J. W.; Choi, J.-H.; Schwarz, L. *Tetrahedron Lett.* **1998**, *39*, 7491-7494.

- (93) Marx, V. M.; Stoddard, R. L.; Heverly-Coulson, G. S.; Burnell, D. J. *Chemistry* **2011**, *17*, 8098-8104.
- (94) Marx, V. M.; Burnell, D. J. *Org. Lett.* **2009**, *11*, 1229-1231.
- (95) Marx, V. M.; Cameron, T. S.; Burnell, D. J. *Tetrahedron Lett.* **2009**, *50*, 7213-7216.
- (96) Marx, V. M.; LeFort, F. M.; Burnell, D. J. *Adv. Synth. Catal.* **2011**, *353*, 64-68.
- (97) Marx, V. M.; Burnell, D. J. *J. Am. Chem. Soc.* **2010**, *132*, 1685-1689.
- (98) Boudreau, J.; Courtemanche, M.-A.; Marx, V. M.; Burnell, D. J.; Fontaine, F.-G. *Chem. Commun.* **2012**, *48*, 11250-11252.
- (99) LeFort, F. M.; Mishra, V.; Dexter, G. D.; Morgan, T. D. R.; Burnell, D. J. *J. Org. Chem.* **2015**, *80*, 5877-5886.
- (100) Jung, M. E.; McCombs, C. A. *Org. Synth.* **1978**, *58*, 163-168.
- (101) Jung, M. E.; Nishimura, N. *J. Am. Chem. Soc.* **1999**, *121*, 3529-3530.
- (102) Carreño, M. C.; García Ruano, J. L.; Remor, C. Z.; Urbano, A. *Tetrahedron: Asymmetry* **2000**, *11*, 4279-4296.
- (103) Fettes, K.; McQuire, L.; Murray, A. W. *J. Chem. Soc., Perkin Trans. I* **1995**, 2123-2127.
- (104) Giguere, R. J.; Duncan, S. M.; Bean, J. M.; Purvis, L. *Tetrahedron Lett.* **1988**, *29*, 6071-6074.
- (105) Prié, G.; Prévost, N.; Twin, H.; Fernandes, S. A.; Hayes, J. F.; Shipman, M. *Angew. Chem. Int. Ed.* **2004**, *43*, 6517-6519.
- (106) Harmata, M.; Rashatasakhon, P.; Barnes, C. L. *Can. J. Chem.* **2006**, *84*, 1456-1469.
- (107) Cramer, C. J.; Harmata, M.; Rashatasakhon, P. *J. Org. Chem.* **2001**, *66*, 5641-5644.
- (108) Morgan, T. D. R.; LeFort, F. M.; Li, Z.; Marx, V. M.; Boyd, R. J.; Burnell, D. J. *Eur. J. Org. Chem.* **2015**, 2952-2959.
- (109) Stonehouse, J.; Adell, P.; Keeler, J.; Shaka, A. J. *J. Am. Chem. Soc.* **1994**, *116*, 6037-6038.
- (110) Stott, K.; Stonehouse, J.; Keeler, J.; Hwang, T.-L.; Shaka, A. J. *J. Am. Chem. Soc.* **1995**, *117*, 4199-4200.

- (111) Wan, C. S. K.; Weedon, A. C.; Wong, D. F. *J. Org. Chem.* **1986**, *51*, 3335-3341.
- (112) Hampel, T.; Brückner, R. *Org. Lett.* **2009**, *11*, 4842-4845.
- (113) Wouters, F. C.; Rocha, D. F.; Gonçalves, C. C. S.; Machado, G.; Marsaioli, A. J. *J. Nat. Prod.* **2013**, *76*, 1559-1564.
- (114) Chanthamath, S.; Takaki, S.; Shibatomi, K.; Iwasa, S. *Angew. Chem. Int. Ed.* **2013**, *52*, 5818-5821.
- (115) Ireland, R. E.; Thompson, W. J. *J. Org. Chem.* **1979**, *44*, 3041-3052.
- (116) Jung, M. E.; Ho, D. G. *Org. Lett.* **2007**, *9*, 375-378.
- (117) Krebs, A.; Wilke, J. *Top. Curr. Chem.* **1983**, *109*, 189-233.
- (118) Wittig, G.; Harboth, G. *Ber. Dtsch. Chem. Ges.* **1944**, *77*, 306-314.
- (119) Scardiglia, F.; Roberts, J. D. *Tetrahedron* **1957**, *1*, 343-344.
- (120) Montgomery, L. K.; Applegate, L. E. *J. Am. Chem. Soc.* **1967**, *89*, 5305-5307.
- (121) Caubere, P.; Brunet, J. J. *Tetrahedron Lett.* **1969**, *39*, 3323-3326.
- (122) Caubere, P.; Brunet, J. J. *Tetrahedron* **1971**, *27*, 3515-3526.
- (123) Harada, T.; Iwazaki, K.; Otani, T.; Oku, A. *J. Org. Chem.* **1998**, *63*, 9007-9012.
- (124) Fixari, B.; Brunet, J. J.; Caubere, P. *Tetrahedron* **1976**, *32*, 927-934.
- (125) Atanes, N.; Escudero, S.; Pérez, D.; Guitián, E.; Castedo, L. *Tetrahedron Lett.* **1998**, *39*, 3039-3040.
- (126) Zhdankin, V. K. *Chem. Rev.* **2008**, *108*, 5299-5358.
- (127) Fujita, M.; Sakanishi, Y.; Kim, W. H.; Okuyama, T. *Chem. Lett.* **2002**, 908-909.
- (128) Fujita, M.; Kim, W. H.; Sakanishi, Y.; Fujiwara, K.; Hirayama, S.; Okuyama, T.; Ohki, Y.; Tatsumi, K.; Yoshioka, Y. *J. Am. Chem. Soc.* **2004**, *126*, 7548-7558.
- (129) Gampe, C. M.; Boulos, S.; Carreira, E. M. *Angew. Chem. Int. Ed.* **2010**, *49*, 4092-4095.

- (130) Bennett, M. A.; Robertson, G. B.; Whimp, P. O.; Yoshida, T. *J. Am. Chem. Soc.* **1971**, *93*, 3797-3798.
- (131) Robertson, G. B.; Whimp, P. O. *J. Organomet. Chem.* **1971**, *32*, C69-C71.
- (132) Bennett, M. A.; Robertson, G. B.; Whimp, P. O.; Yoshida, T. *J. Am. Chem. Soc.* **1973**, *95*, 3028-3030.
- (133) Robertson, G. B.; Whimp, P. O. *J. Am. Chem. Soc.* **1975**, *97*, 1051-1059.
- (134) Bennett, M. A.; Fick, H.-G.; Warnock, G. F. *Aust. J. Chem.* **1992**, *45*, 135-142.
- (135) Bennett, M. A.; Yoshida, T. *J. Am. Chem. Soc.* **1978**, *100*, 1750-1759.
- (136) Bennett, M. A.; Johnson, J. A.; Willis, A. C. *Organometallics* **1996**, *15*, 68-74.
- (137) Bennett, M. A.; Wenger, E. *Chem. Ber.* **1997**, *130*, 1029-1045.
- (138) Gampe, C. M.; Carreira, E. M. *Angew. Chem. Int. Ed.* **2011**, *50*, 2962-2965.
- (139) Devlin, A. S.; Du Bois, J. *Chem. Sci.* **2013**, *4*, 1059-1063.
- (140) Nicolaou, K. C.; Ding, H.; Richard, J.-A.; Chen, D. Y.-K. *J. Am. Chem. Soc.* **2010**, *132*, 3815-3818.
- (141) Yadav, V. K.; Senthil, G.; Babu, K. G.; Parvez, M.; Reid, J. L. *J. Org. Chem.* **2002**, *67*, 1109-1117.
- (142) Chih, S.; Fritzen, E. L.; Swenton, J. S. *J. Org. Chem.* **1980**, *45*, 4462-4471.
- (143) Jyothi, D.; HariPrasad, S. *ARKIVOC* **2012**, *6*, 194-203.
- (144) Crisp, G. T.; Scott, W. J. *Synthesis* **1985**, 335-337.
- (145) Iglesias, B.; Peña, D.; Pérez, D.; Guitián, E.; Castedo, L. *Synlett* **2002**, 486-488.
- (146) Peña, D.; Iglesias, B.; Quintana, I.; Pérez, D.; Guitián, E.; Castedo, L. *Pure Appl. Chem.* **2006**, *78*, 451-455.
- (147) Wittig, G.; Mayer, U. *Chem. Ber.* **1963**, *96*, 342-348.

- (148) Yoshida, H.; Tanino, K.; Ohshita, J.; Kunai, A. *Angew. Chem. Int. Ed.* **2004**, *43*, 5052-5055.
- (149) Allan, K. M.; Hong, B. D.; Stoltz, B. M. *Org. Biomol. Chem.* **2009**, *7*, 4960-4964.
- (150) Fujita, M.; Kim, W. H.; Fujiwara, K.; Okuyama, T. *J. Org. Chem.* **2005**, *70*, 480-488.
- (151) Marques, F. A.; Lenz, C. A.; Simonelli, F.; Noronha Sales Maia, B. H. L.; Vellasco, A. P.; Eberlin, M. N. *J. Nat. Prod.* **2004**, *67*, 1939-1941.
- (152) Noyori, R.; Murata, S.; Suzuki, M. *Tetrahedron* **1981**, *37*, 3899-3910.
- (153) Comins, D. L.; Dehghani, A. *Tetrahedron Lett.* **1992**, *33*, 6299-6302.
- (154) Xu, X.; Li, X.; Wang, A.; Sun, Y.; Schweizer, W. B.; Prins, R. *Helv. Chim. Acta* **2011**, *94*, 1754-1763.
- (155) Simaan, S.; Marek, I. *Chem. Commun.* **2009**, 292-294.
- (156) Ishihara, K.; Nakano, K. *J. Am. Chem. Soc.* **2007**, *129*, 8930-8931.
- (157) Curran, D. P.; Turner, T. R. *Beilstein J. Org. Chem.* **2006**, *2*, 1-10.
- (158) Ghosh, P.; Lotesta, S. D.; Williams, L. J. *J. Am. Chem. Soc.* **2007**, *129*, 2438-2439.
- (159) Driscoll, S. P. *A Computational Study of Cyclic Alkynes and the Search for Selectivity in the Cycloadditions of Substituted Cycloalkynes*, M.Sc. Thesis, Dalhousie University, Halifax NS, 2015.
- (160) Wittig, G.; Weinlich, J. *Chem. Ber.* **1965**, *98*, 471-479.
- (161) Bailey, W. F.; Rathman, T. L. *Process Chemistry in the Pharmaceutical Industry, Vol. 2*, CRC Press: Boca Raton, FL, 2008.
- (162) Kim, K.-M.; Park, I.-H. *Synthesis* **2004**, 2641-2644.
- (163) Li, K.; Alexakis, A. *Angew. Chem. Int. Ed.* **2006**, *45*, 7600-7603.
- (164) Smith III, A. B.; Branca, S. J.; Pilla, N. N.; Guaciaro, M. A. *J. Org. Chem.* **1982**, *47*, 1855-1869.
- (165) Brand, S.; Gleiter, R. *J. Org. Chem.* **1997**, *62*, 4385-4389.
- (166) Dunn, T. B.; Ellis, J. M.; Kofink, C. C.; Manning, J. R.; Overman, L. E. *Org. Lett.* **2009**, *11*, 5658-5661.

- (167) Turaček, F.; Vystrčil, A. *Coll. Czech. Chem. Commun.* **1977**, *42*, 2408-2414.
- (168) Wińska, K.; Grudniewska, A.; Chojnacka, A.; Bialońska, A.; Wawrzęńczyk, C. *Tetrahedron: Asymmetry* **2010**, *21*, 670-678.
- (169) Buckley, D. J.; McKervey, M. A. *J. Chem. Soc., Perkin Trans. 1* **1985**, 2193-2200.
- (170) Carlson, R.; Gautun, H.; Westerlund, A. *Adv. Synth. Catal.* **2002**, *344*, 57-60.
- (171) Mahanta, A.; Adhikari, P.; Bora, U.; Thakur, A. J. *Tetrahedron Lett.* **2015**, *56*, 1780-1783.
- (172) Naresh, M.; Arun Kumar, M.; Mahender Reddy, M.; Swamy, P.; Nanubolu, J.; Narender, N. *Synthesis* **2013**, *45*, 1497-1504.
- (173) Martínez, I.; Aldord, P. E.; Ovaska, T. V. *Org. Lett.* **2005**, *7*, 1133-1135.
- (174) Voigt, K.; von Zezschwitz, P.; Rosauer, K.; Lansky, A.; Adams, A.; Reiser, O.; de Meijere, A. *Eur. J. Org. Chem.* **1998**, 1521-1534.
- (175) Shirai, H.; Amano, N.; Hashimoto, Y.; Fukui, E.; Ishii, Y.; Ogawa, M. *J. Org. Chem.* **1991**, *56*, 2253-2256.
- (176) Resch, V.; Seidler, C.; Chen, B.-S.; Degeling, I.; Hanfeld, U. *Eur. J. Org. Chem.* **2013**, 7697-7704.
- (177) West, F. G.; Hartke-Karger, C.; Koch, D. J.; Kuehn, C. E.; Arif, A. *M. J. Org. Chem.* **1993**, *58*, 6795-6803.

Appendix A: ^1H and ^{13}C NMR Spectra for Chapter 2

¹H NMR (CDCl₃, 500 MHz): 1-Ethyl 8-(2-hydroxyethyl) 4-methyl-5-oxooctanedioate (58)

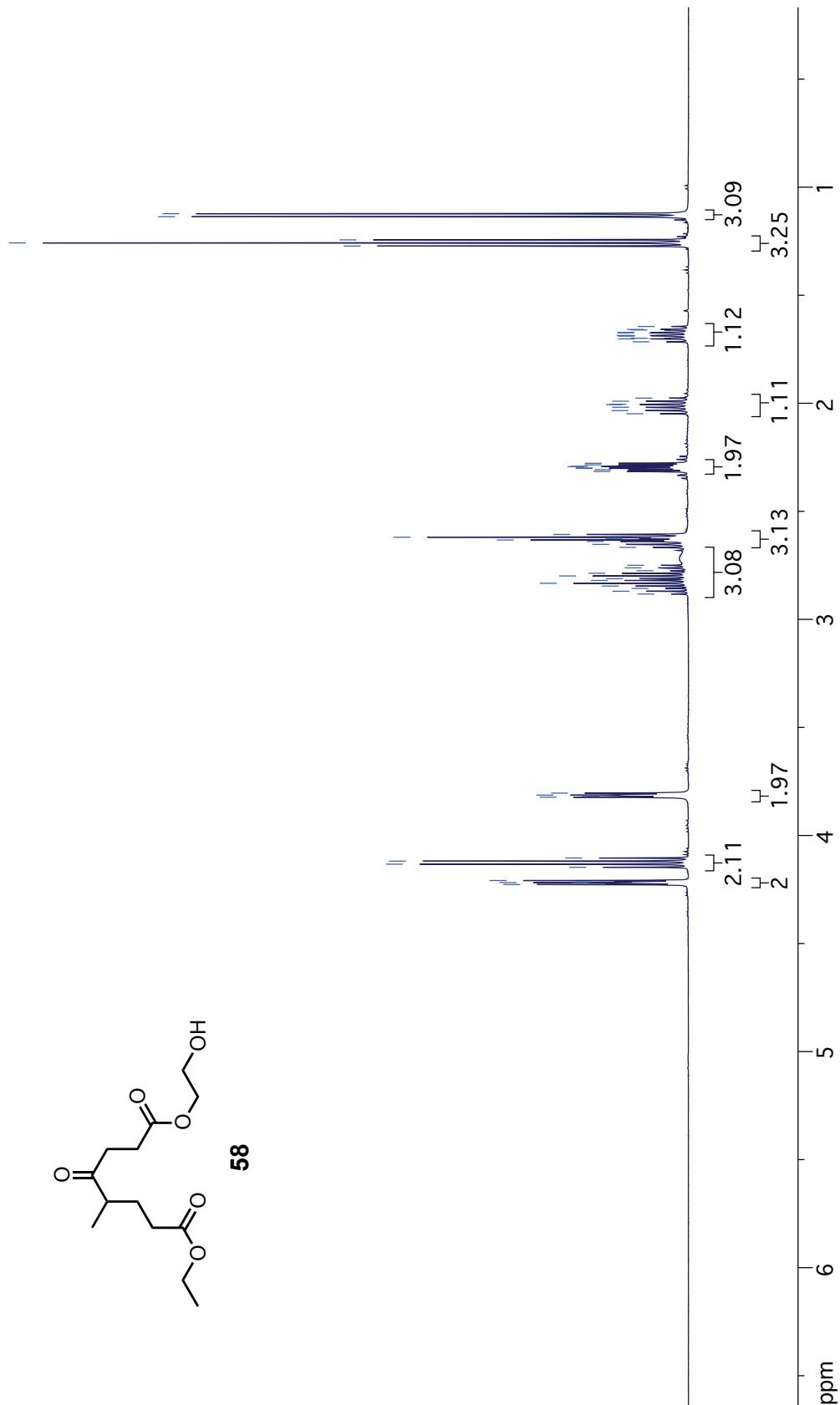
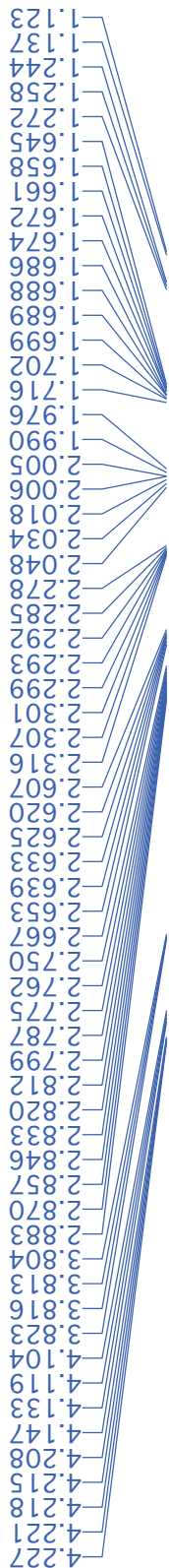

¹³C NMR (CDCl₃, 126 MHz): 1-Ethyl 8-(2-hydroxyethyl) 4-methyl-5-oxooctanedioate (58)

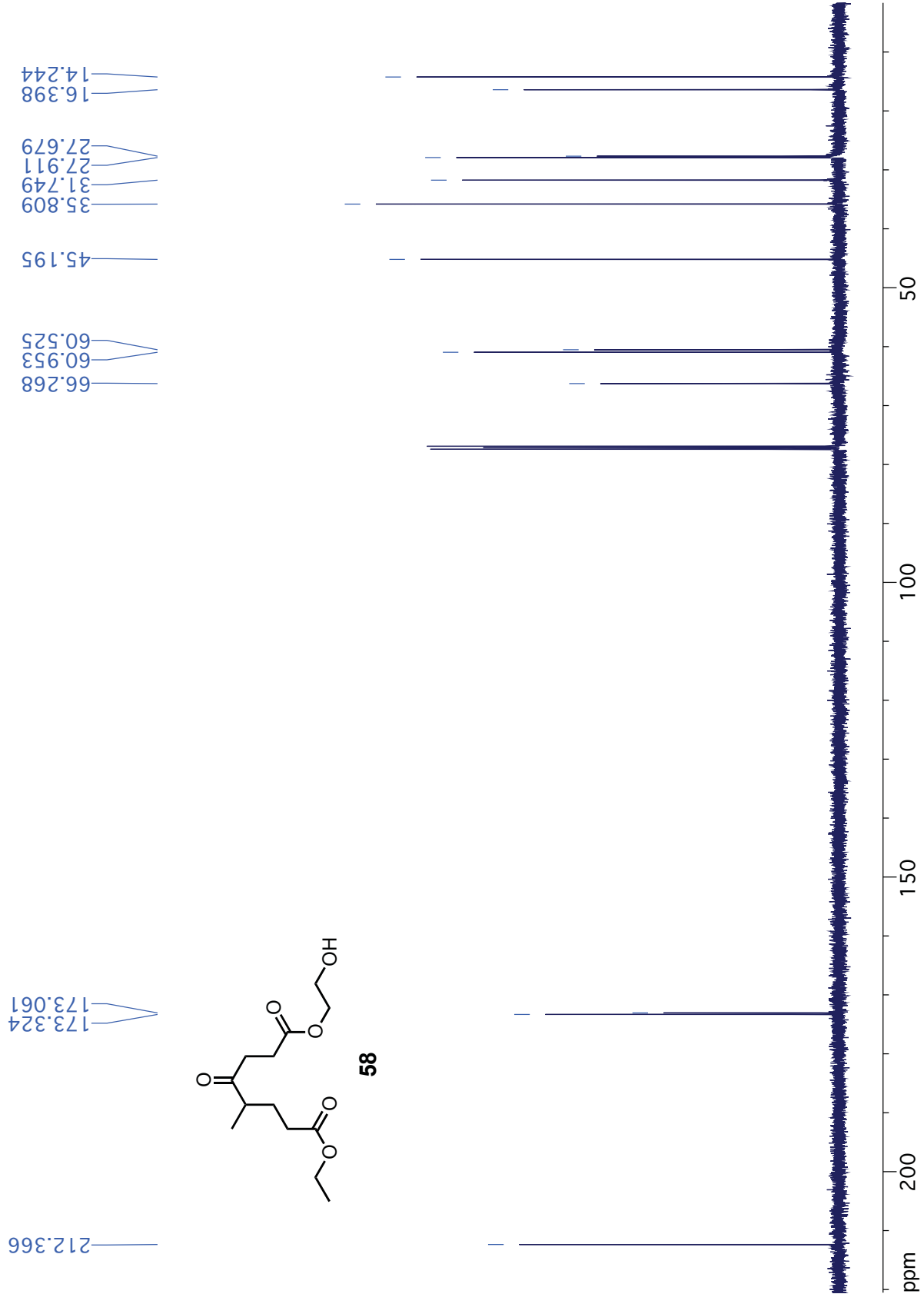

¹H NMR (CDCl₃, 500 MHz): Dimethyl 4-methyl-5-oxononanedioate (60)

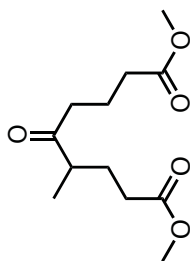

60

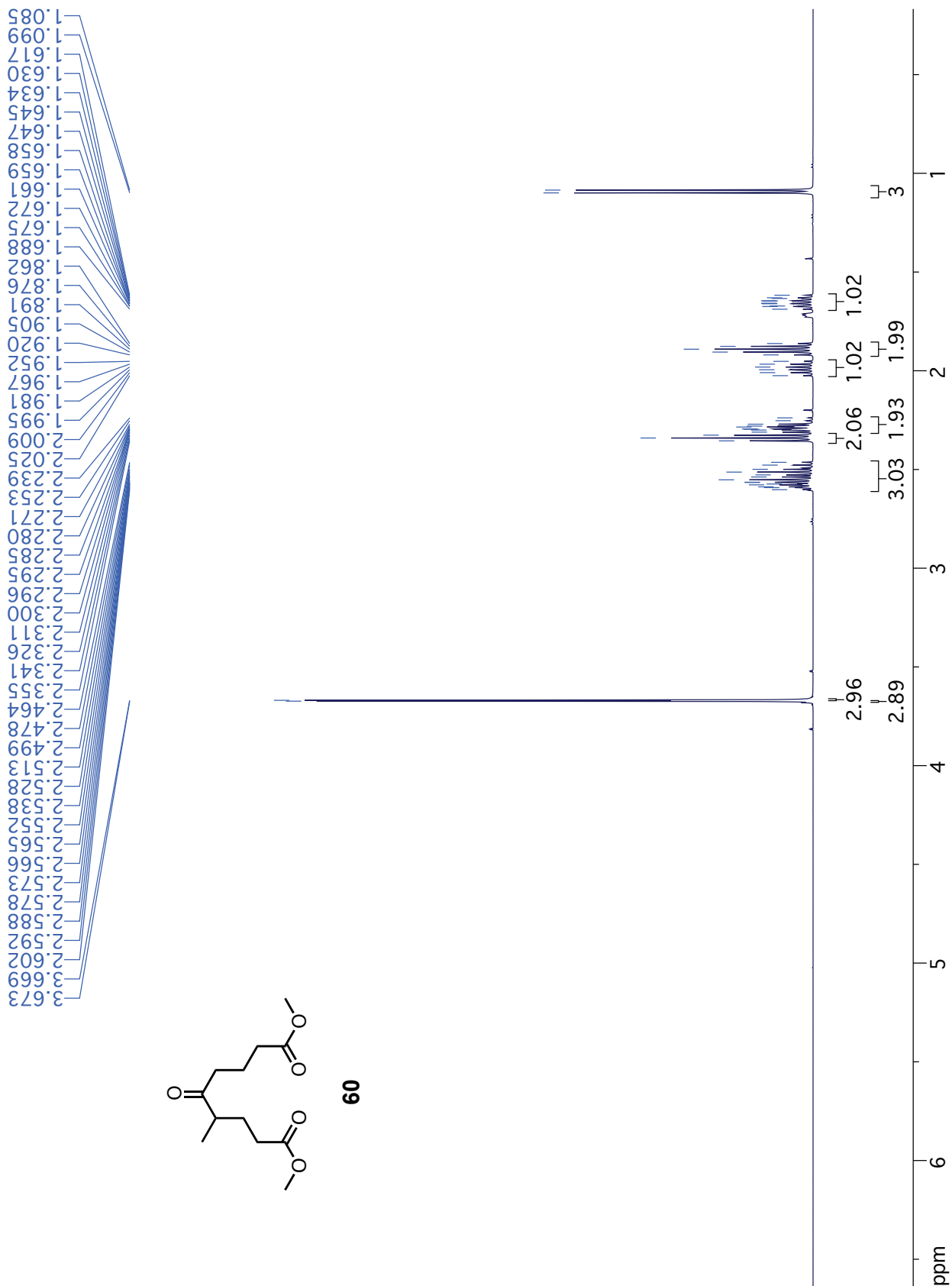

¹³C NMR (CDCl₃, 126 MHz): Dimethyl 4-methyl-5-oxononanedioate (60)

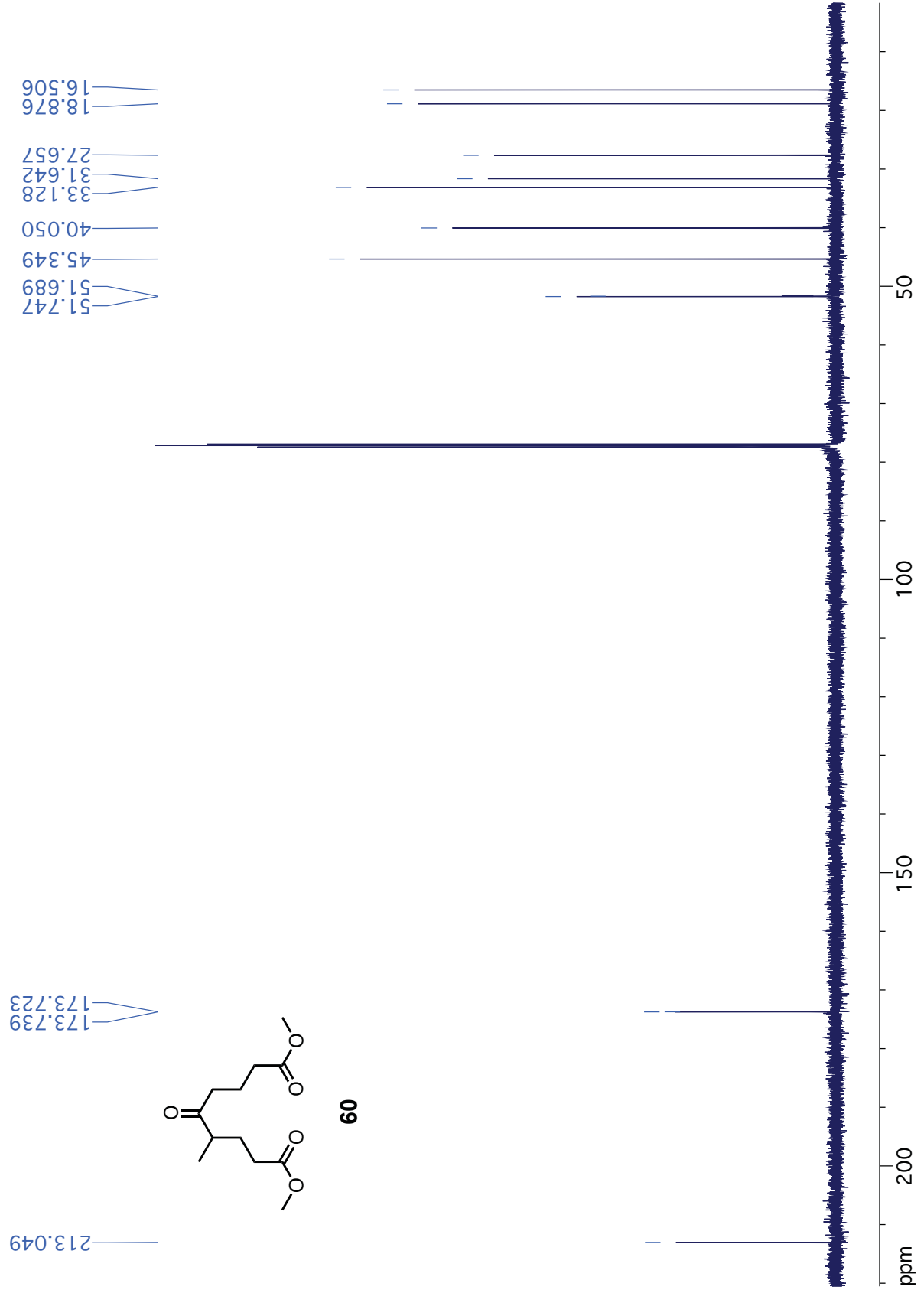

¹H NMR (CDCl₃, 500 MHz): Dimethyl 5-(1,3-dioxolan-2-yl)-4-methylnonanedioate (61)

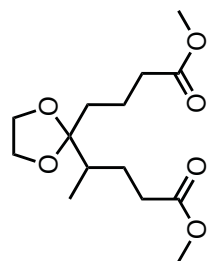
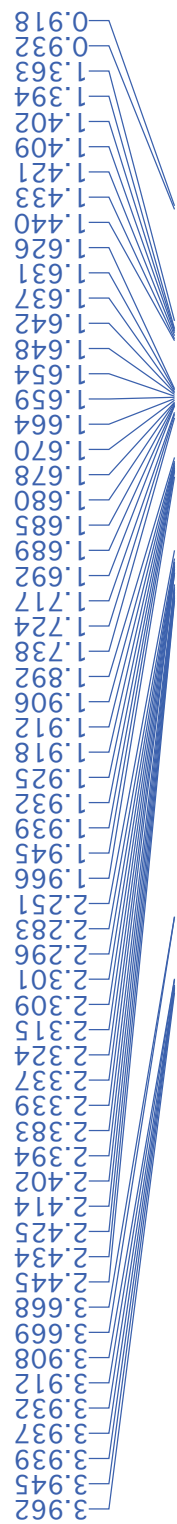

61

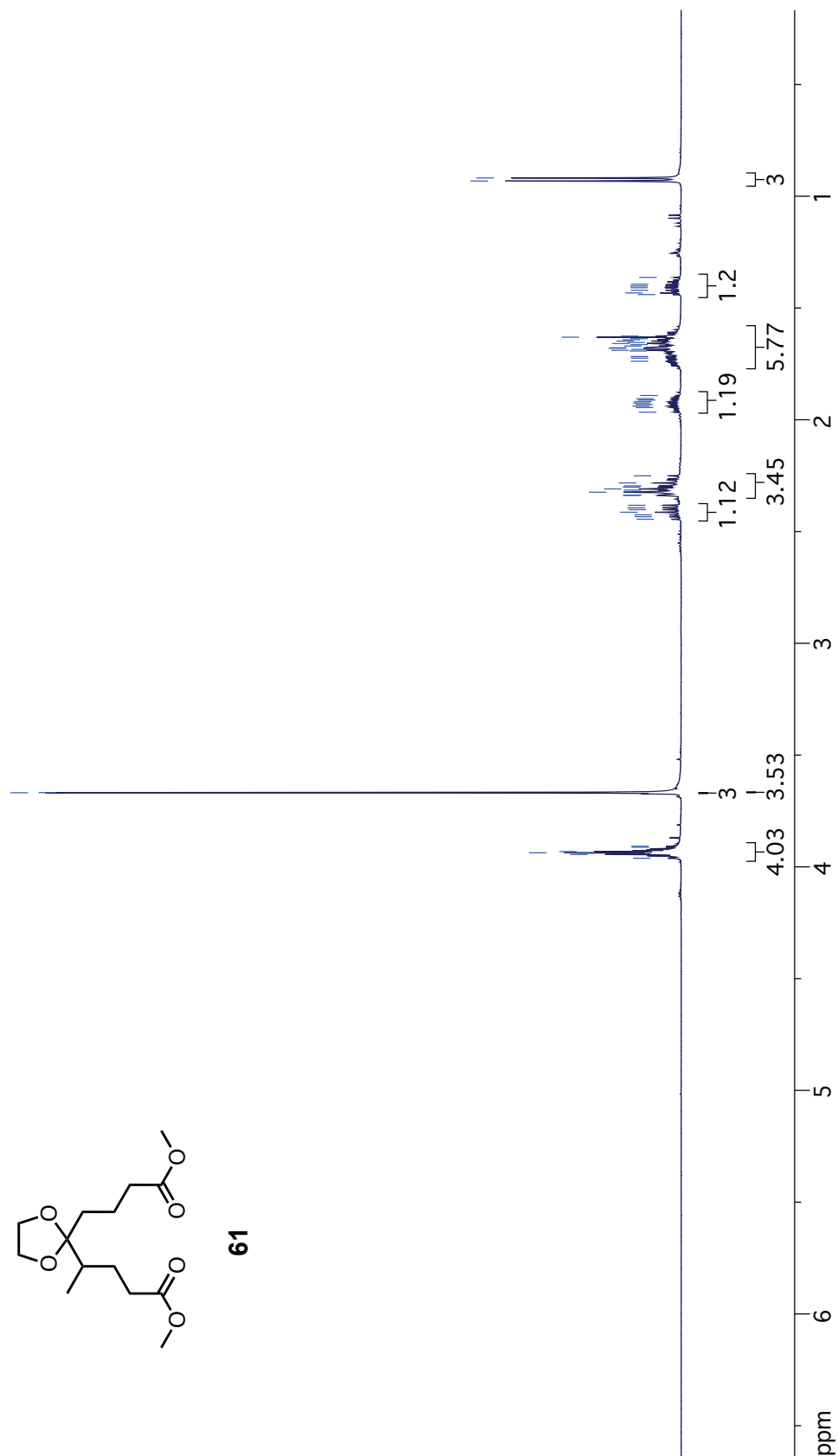

¹³C NMR (CDCl₃, 126 MHz): Dimethyl 5-(1,3-dioxolan-2-yl)-4-methylnonanedioate (61)

65.359
65.285
51.655
51.642
39.218
34.258
33.102
32.611
26.666
18.843
14.241

174.403
174.126
113.338

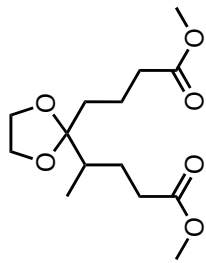

61

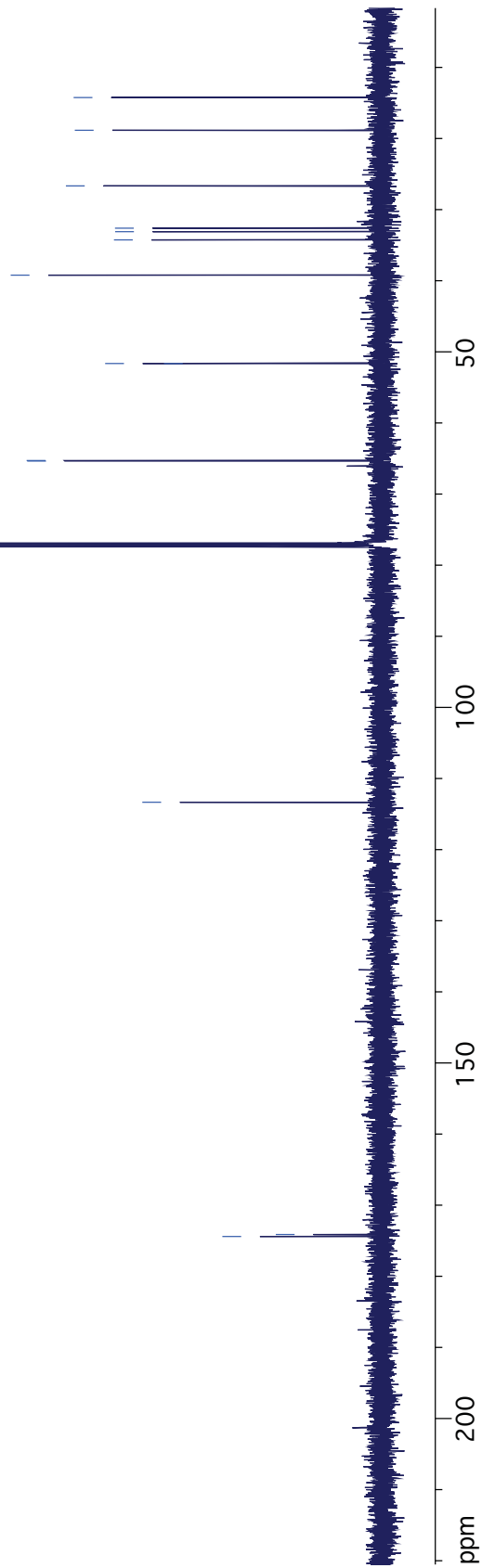

¹H NMR (CDCl₃, 500 MHz): Dimethyl 4-methyl-5-oxooctanedioate (63)

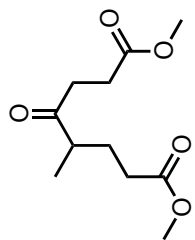

63

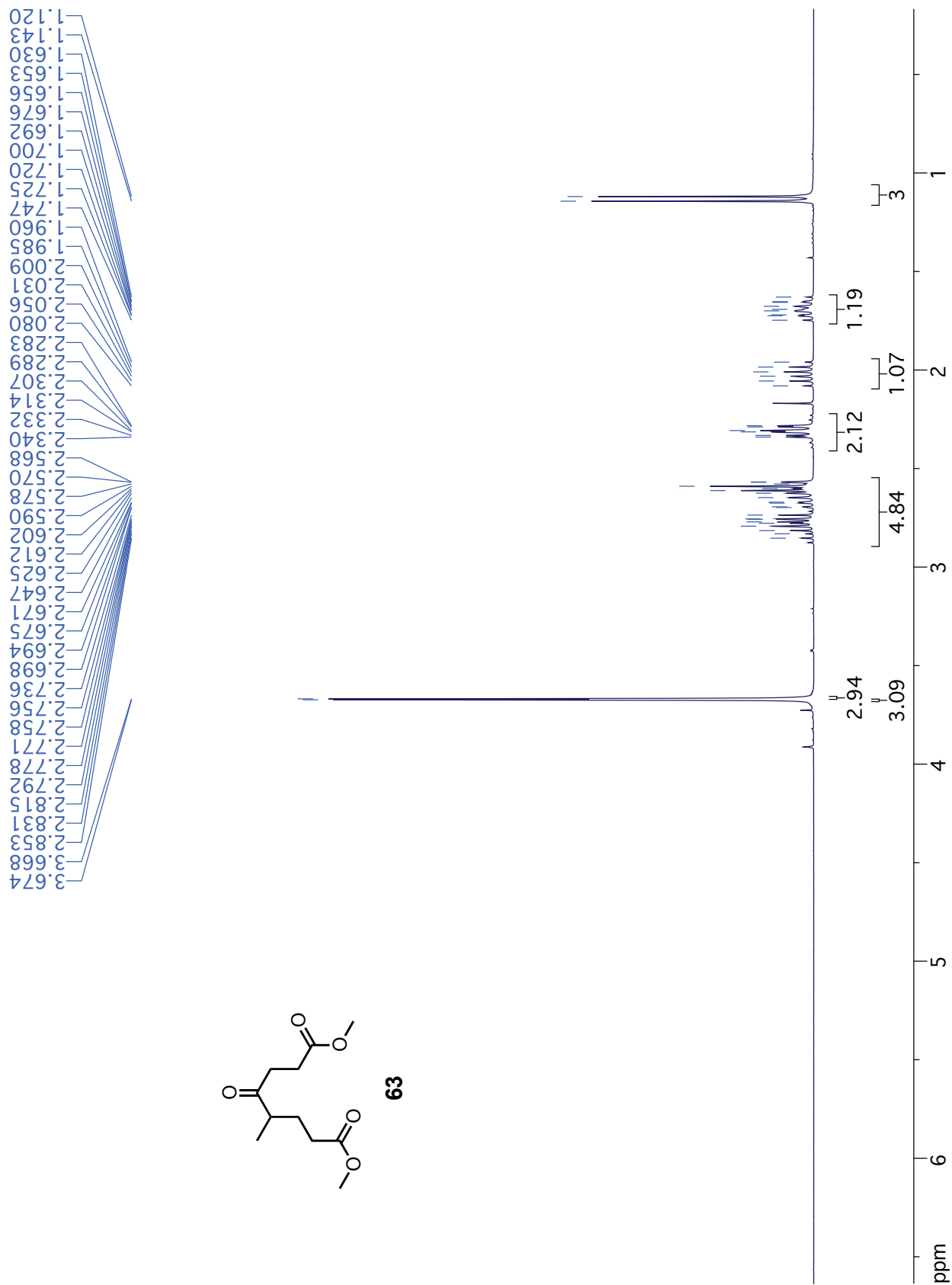

¹³C NMR (CDCl₃, 126 MHz): Dimethyl 4-methyl-5-oxooctanedioate (63)

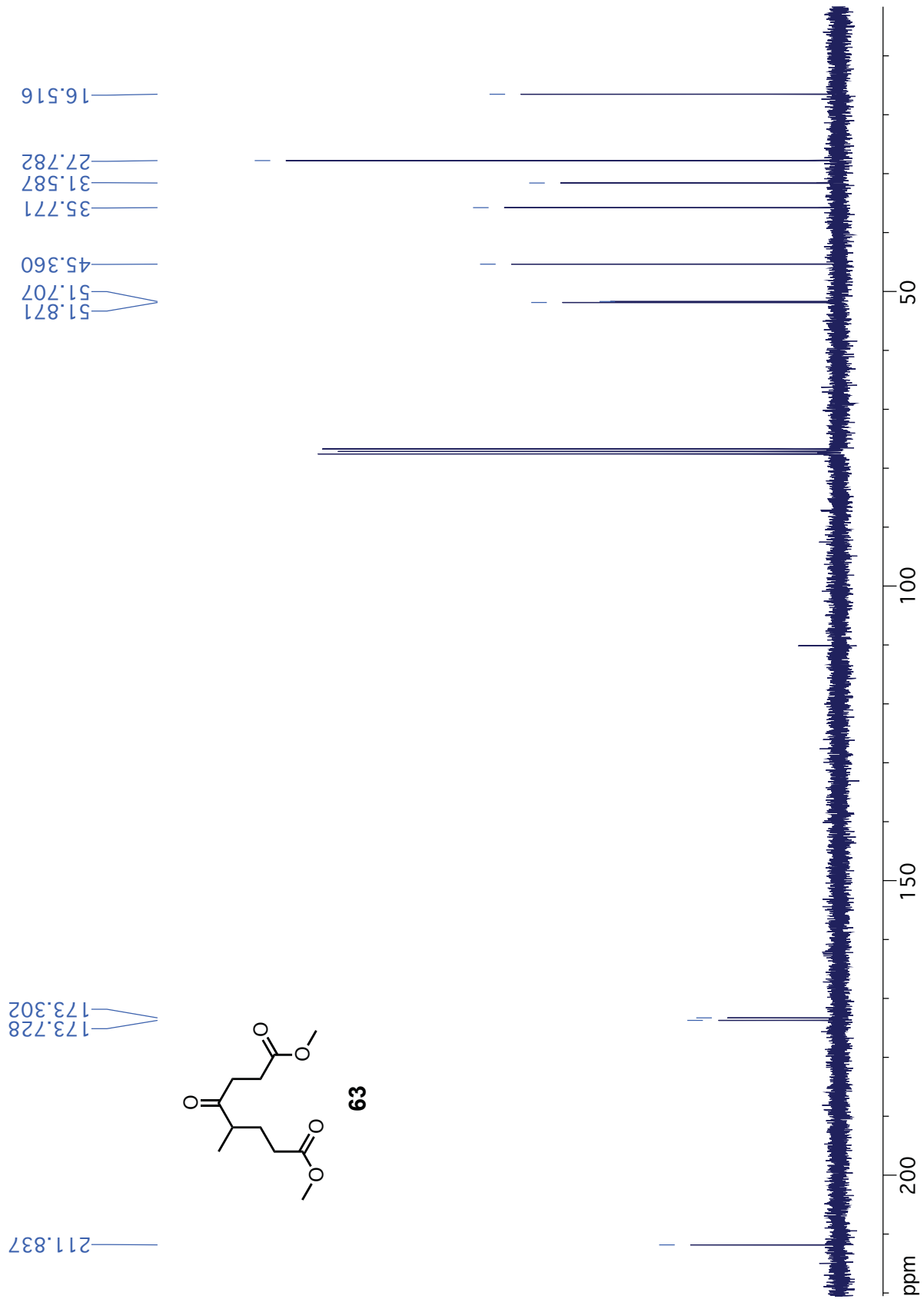

¹³C NMR (CDCl₃, 126 MHz): Dihexyl 4-methyl-5-oxooctanedioate (66)

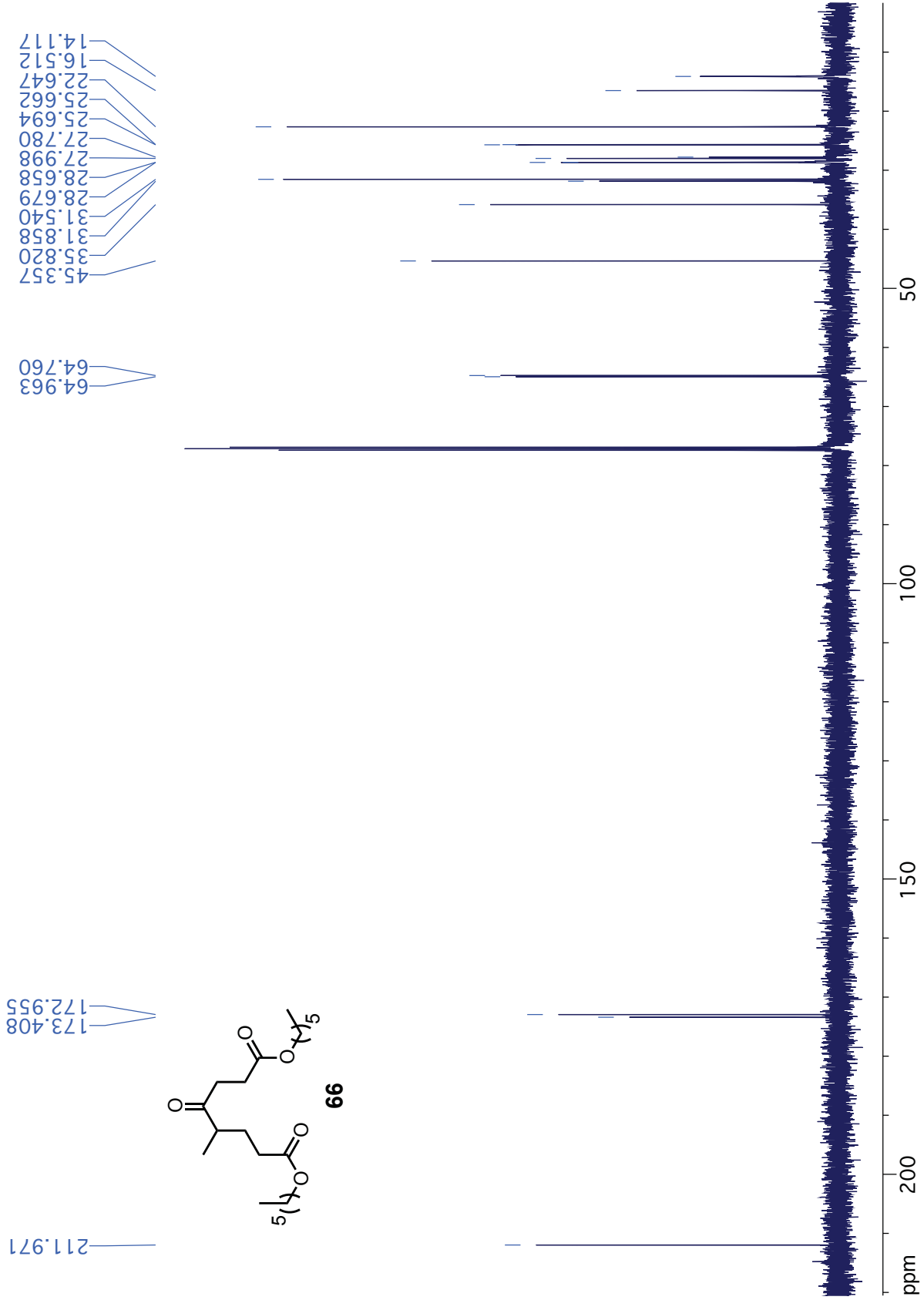

¹H NMR (CDCl₃, 500 MHz): Ethyl 3-(3-hydroxy-1-oxocyclohex-2-en-2-yl)propanoate (70)

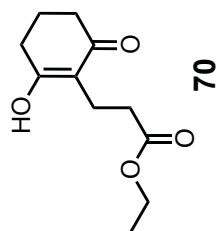
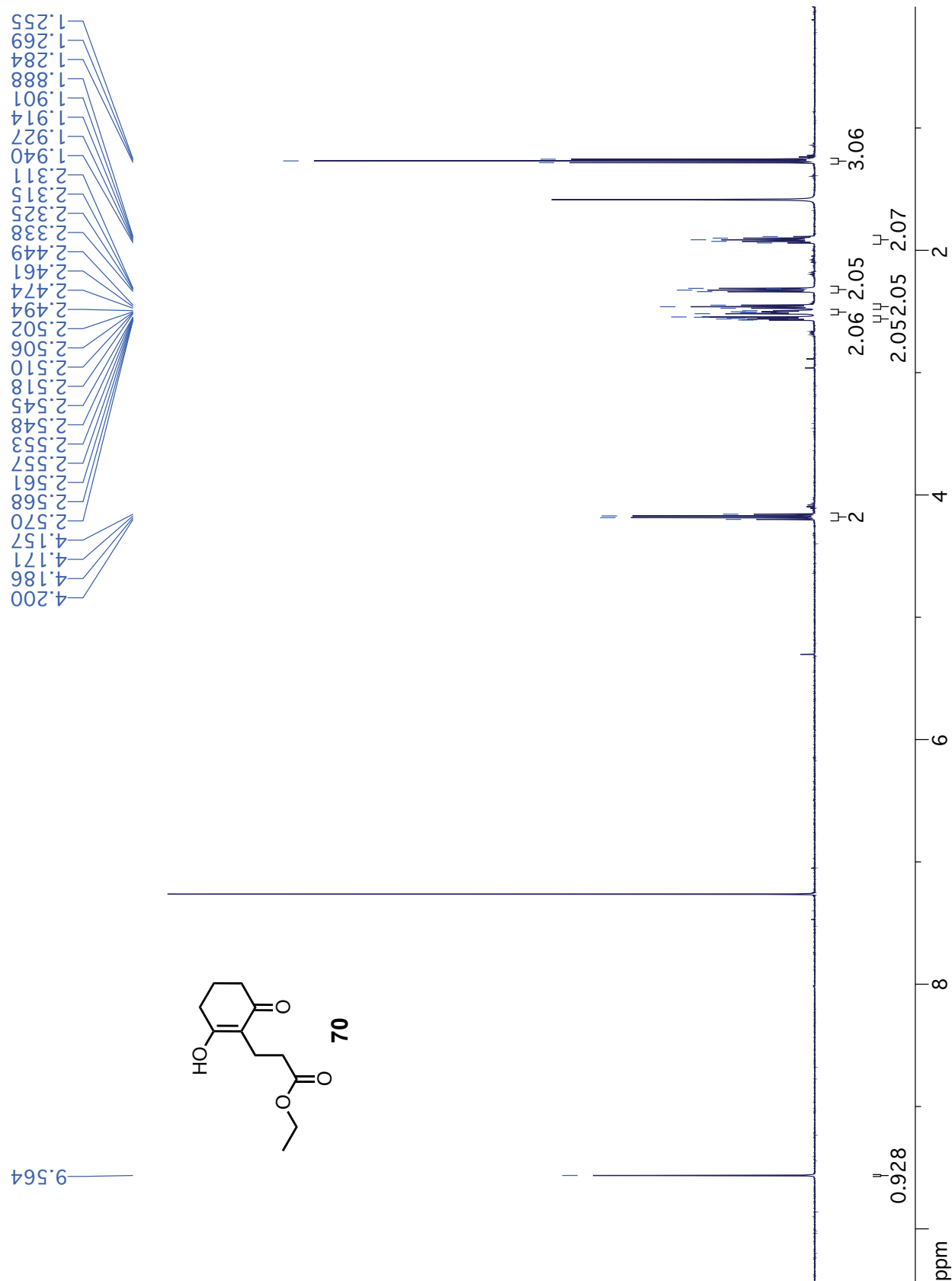

¹³C NMR (CDCl₃, 126 MHz): Ethyl 3-(3-hydroxy-1-oxocyclohex-2-en-2-yl)propanoate (70)

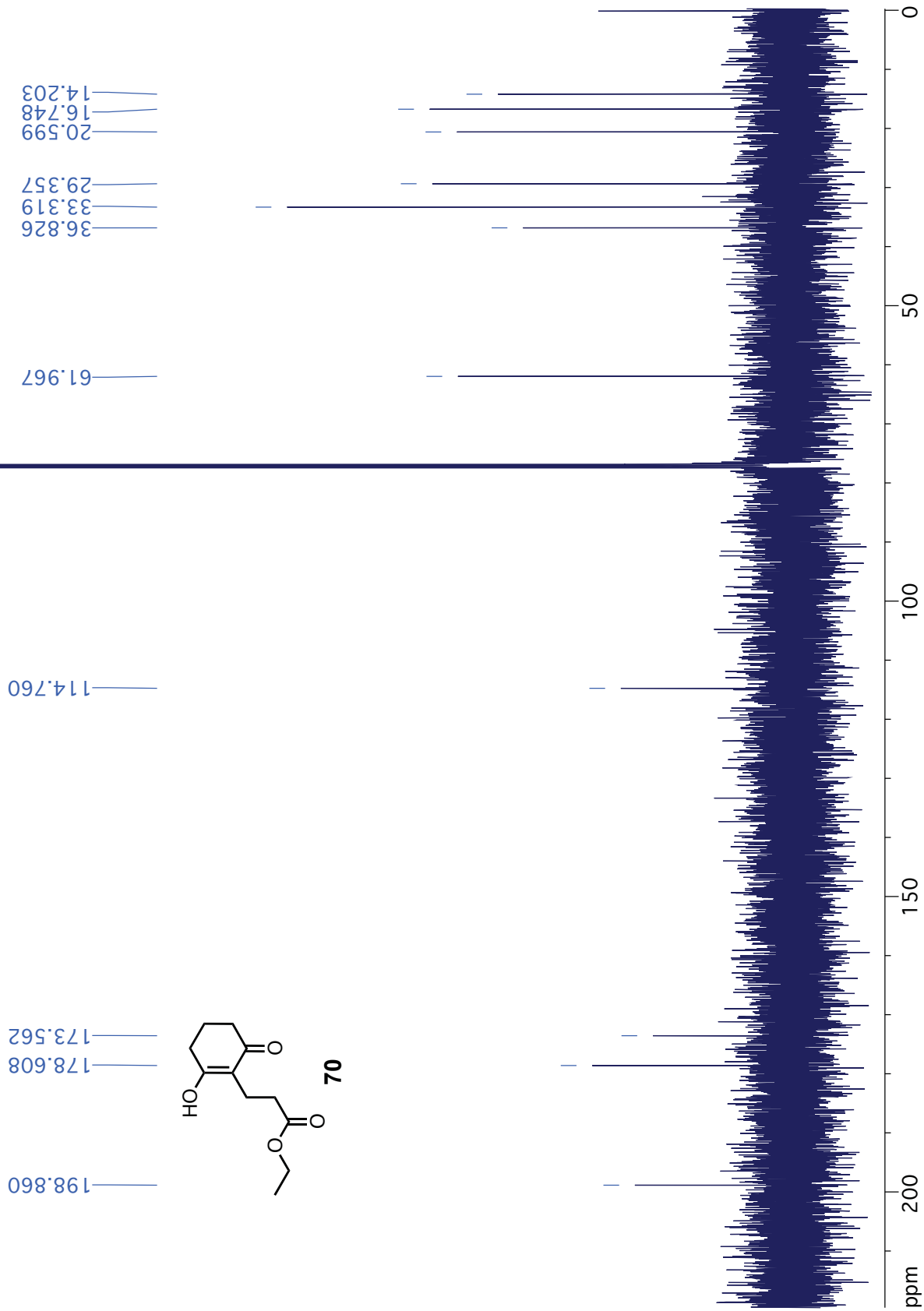

Appendix B: ^1H and ^{13}C NMR Spectra for Chapter 3

¹H NMR (CDCl₃, 500 MHz): (Z)-3-(*tert*-Butyldimethylsilyloxy)-1,3-hexadiene (**101b**)

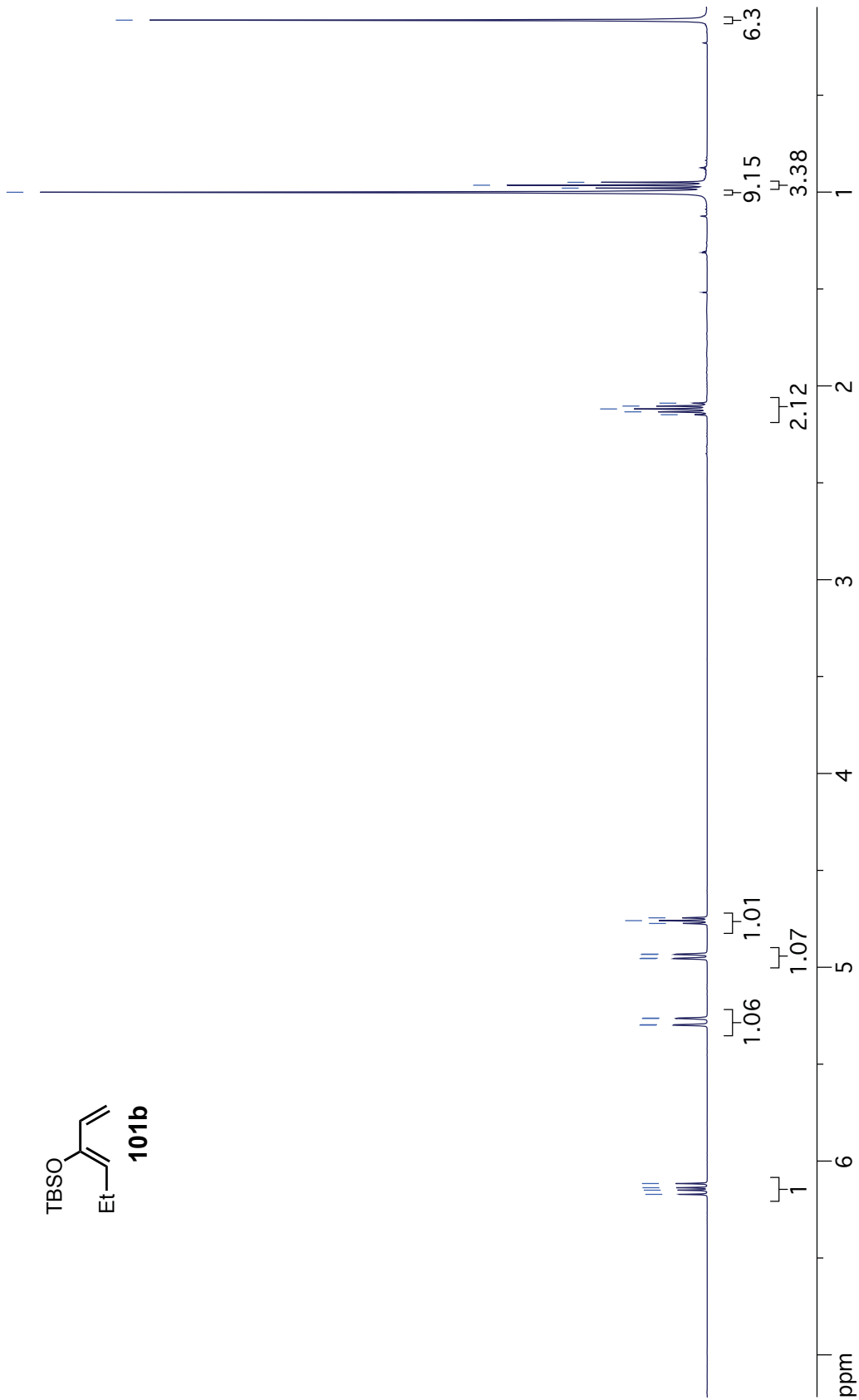

¹³C NMR (CDCl₃, 126 MHz): (Z)-3-(*tert*-Butyldimethylsilyloxy)-1,3-hexadiene (101b)

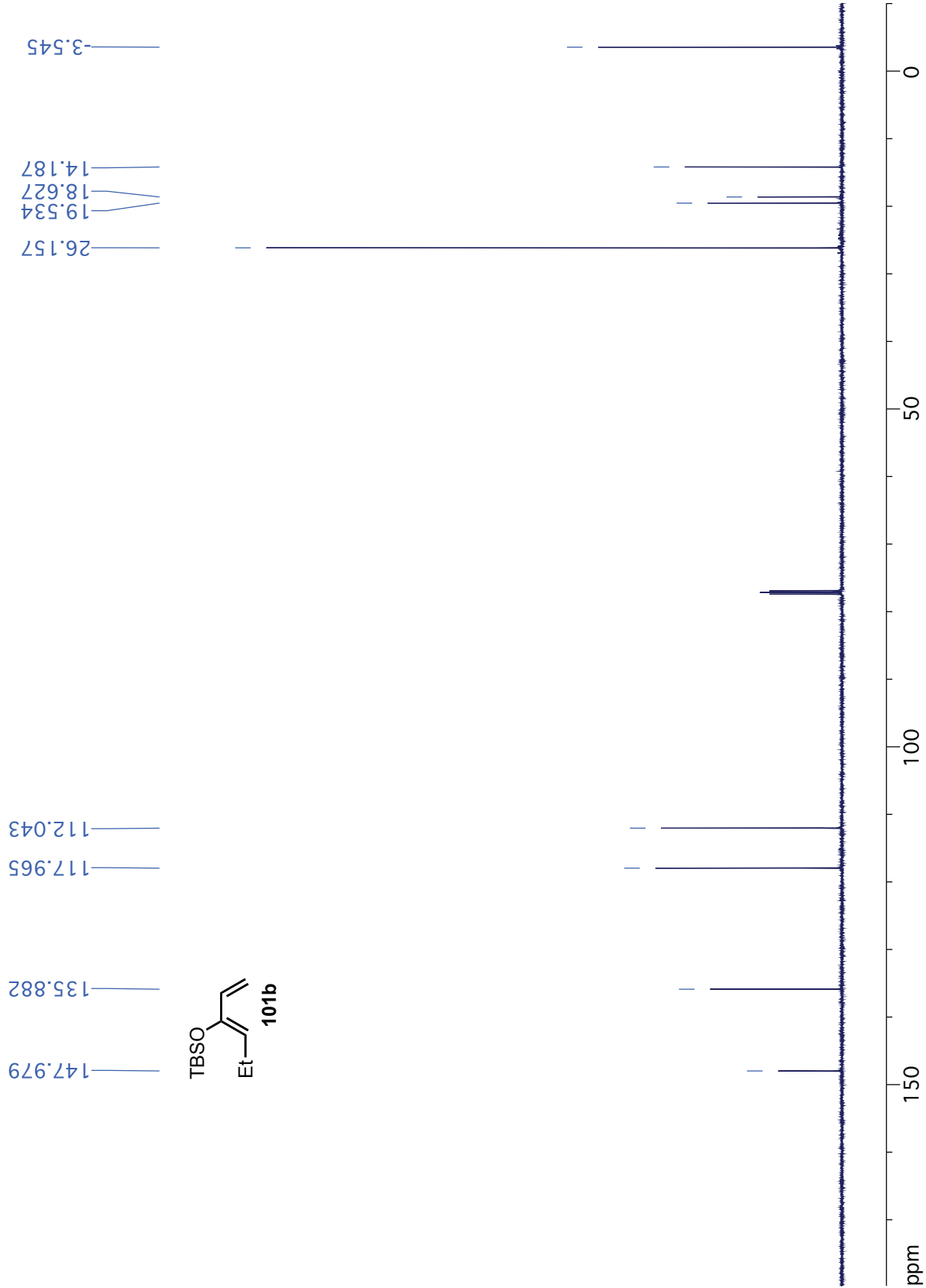

¹H NMR (CDCl₃, 500 MHz): (Z)-3-(*tert*-Butyldimethylsilyloxy)-5-methyl-1,3-hexadiene (101c)

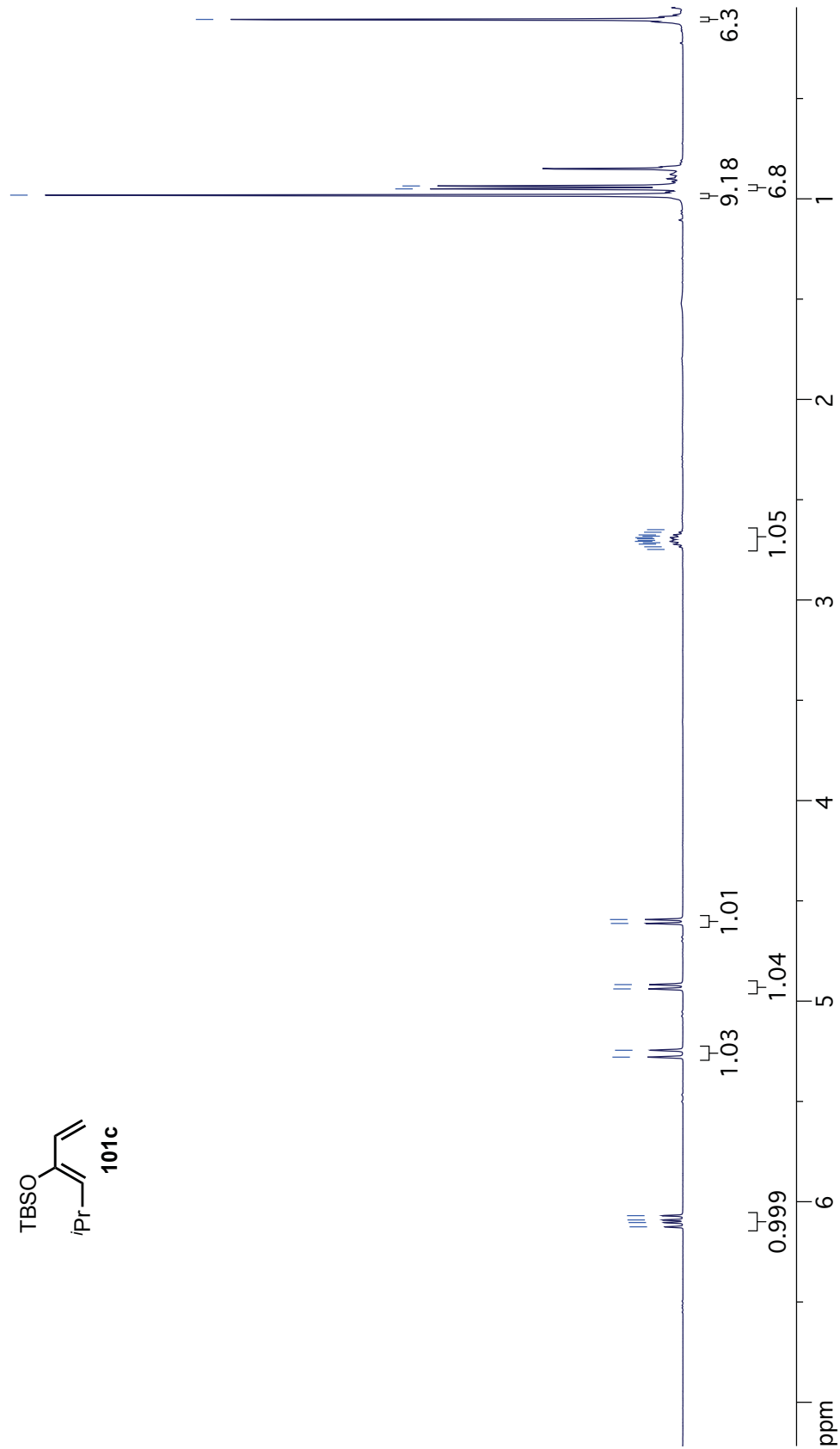
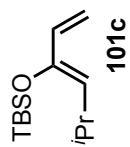
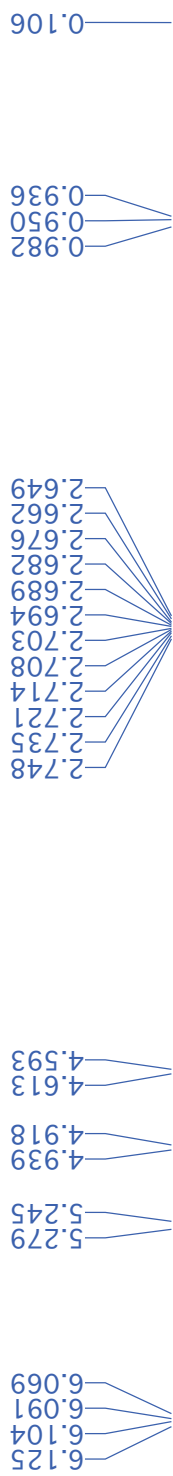

¹³C NMR (CDCl₃, 126 MHz): (Z)-3-(*tert*-Butyldimethylsilyloxy)-5-methyl-1,3-hexadiene (101c)

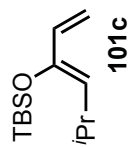
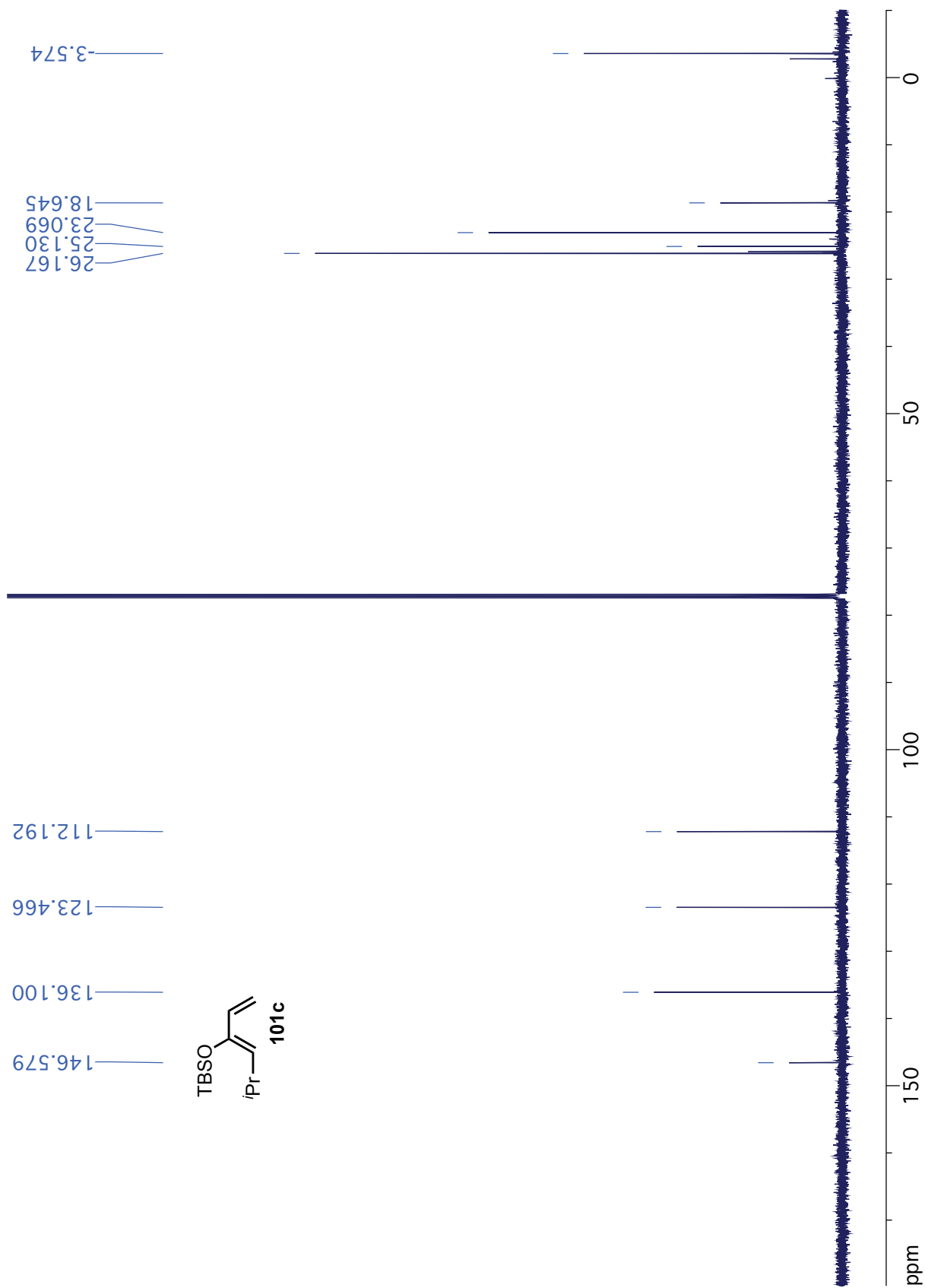

¹H NMR (CDCl₃, 500 MHz): (E)-2-(tert-Butyldimethylsilyloxy)-1-phenyl-1,3-butadiene (E-101d)

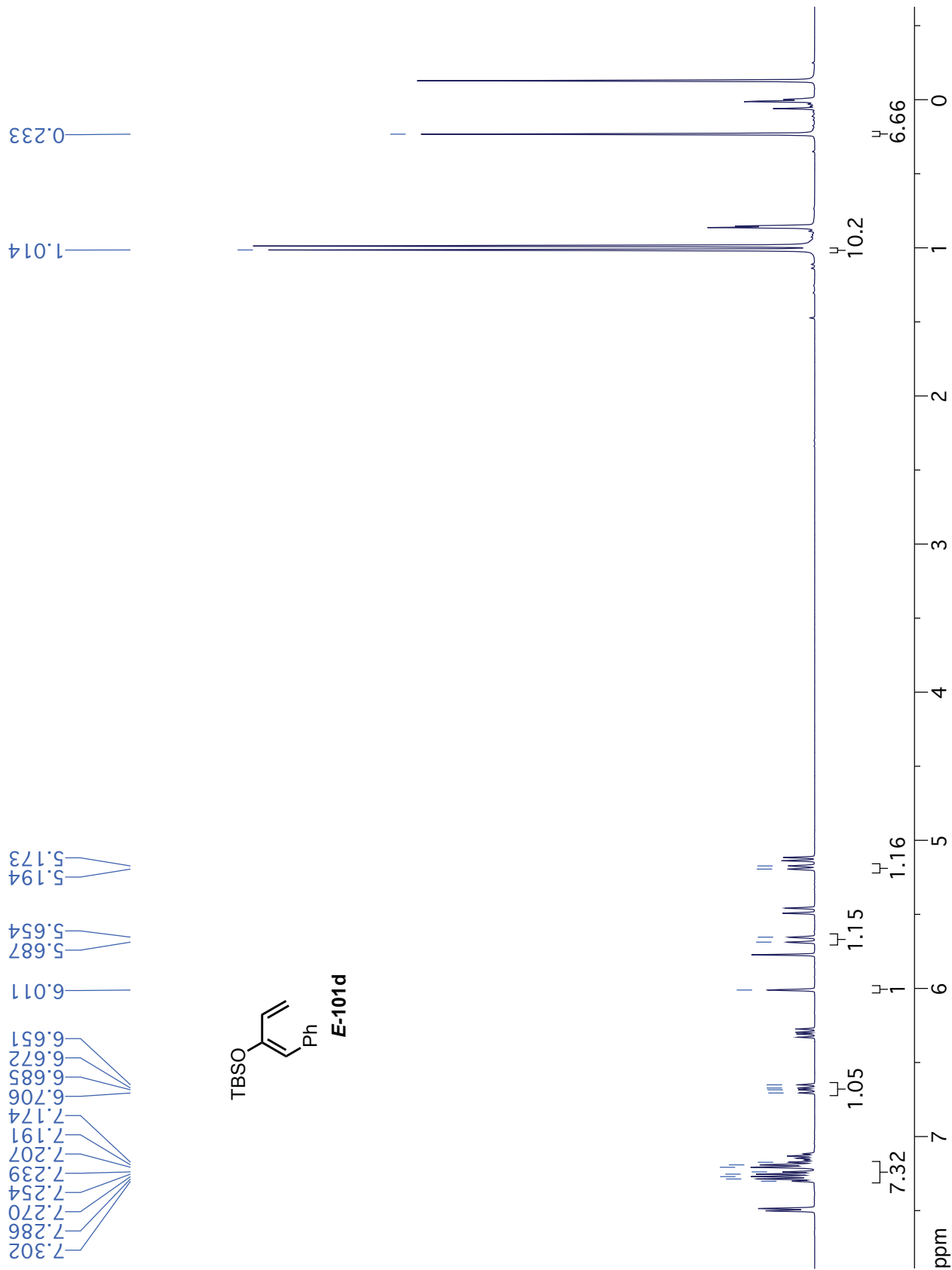
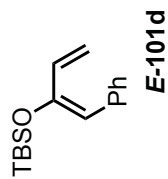
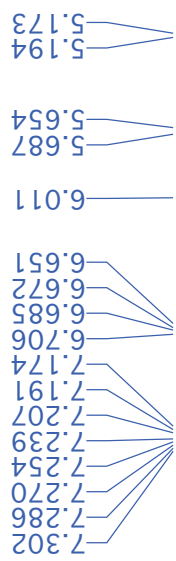

¹³C NMR (CDCl₃, 126 MHz): (E)-2-(*tert*-Butyldimethylsilyloxy)-1-phenyl-1,3-butadiene (E-101d)

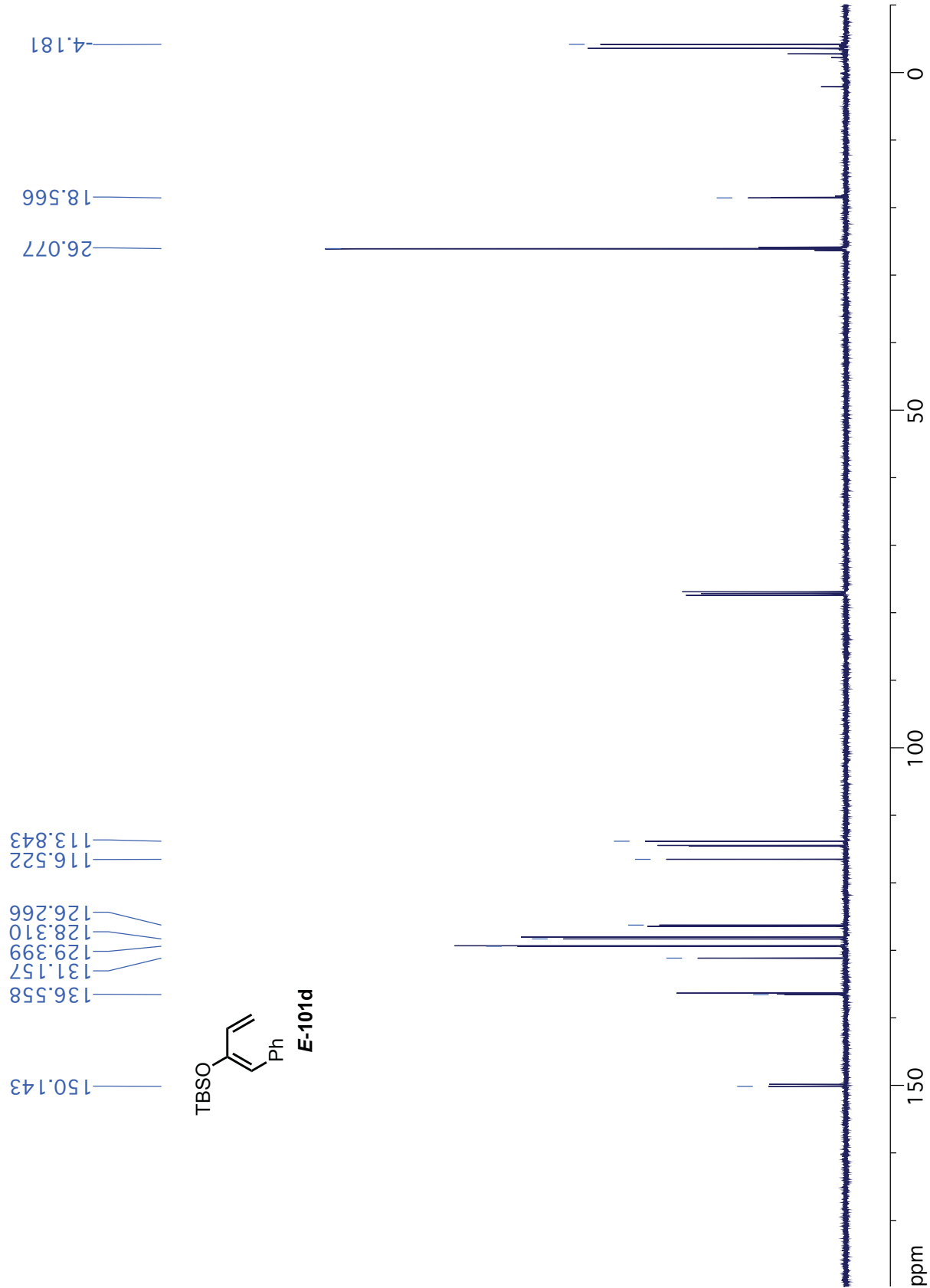

¹H NMR (CDCl₃, 500 MHz): (Z)-2-(*tert*-Butyldimethylsilyloxy)-1-phenyl-1,3-butadiene (Z-101d)

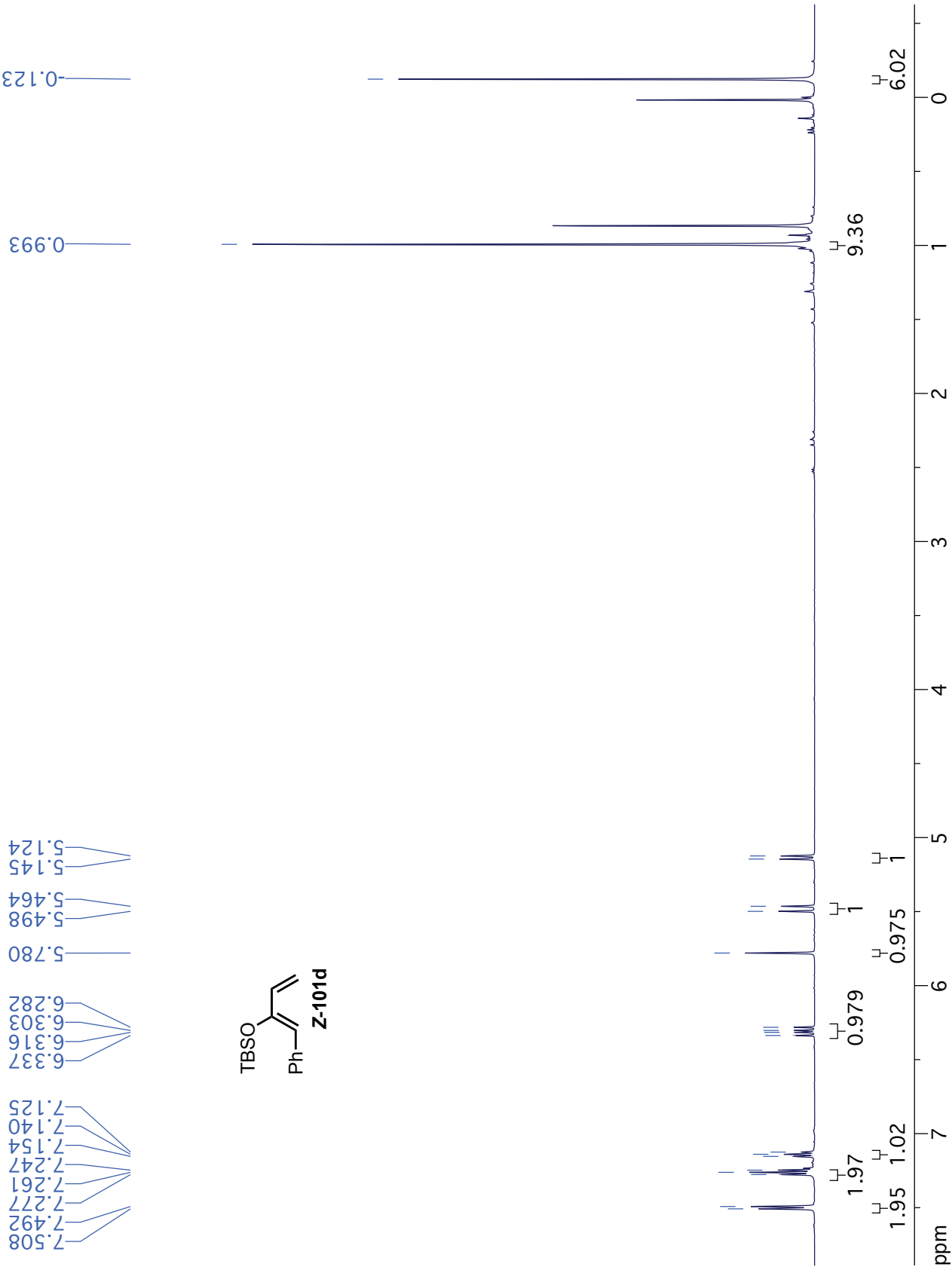
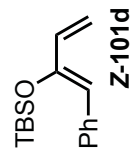
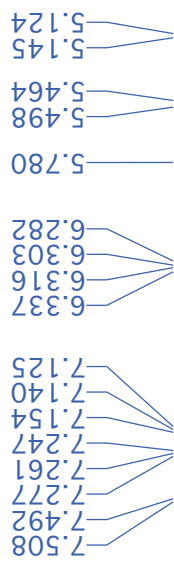

¹³C NMR (CDCl₃, 126 MHz): (Z)-2-(*tert*-Butyldimethylsilyloxy)-1-phenyl-1,3-butadiene (Z-101d)

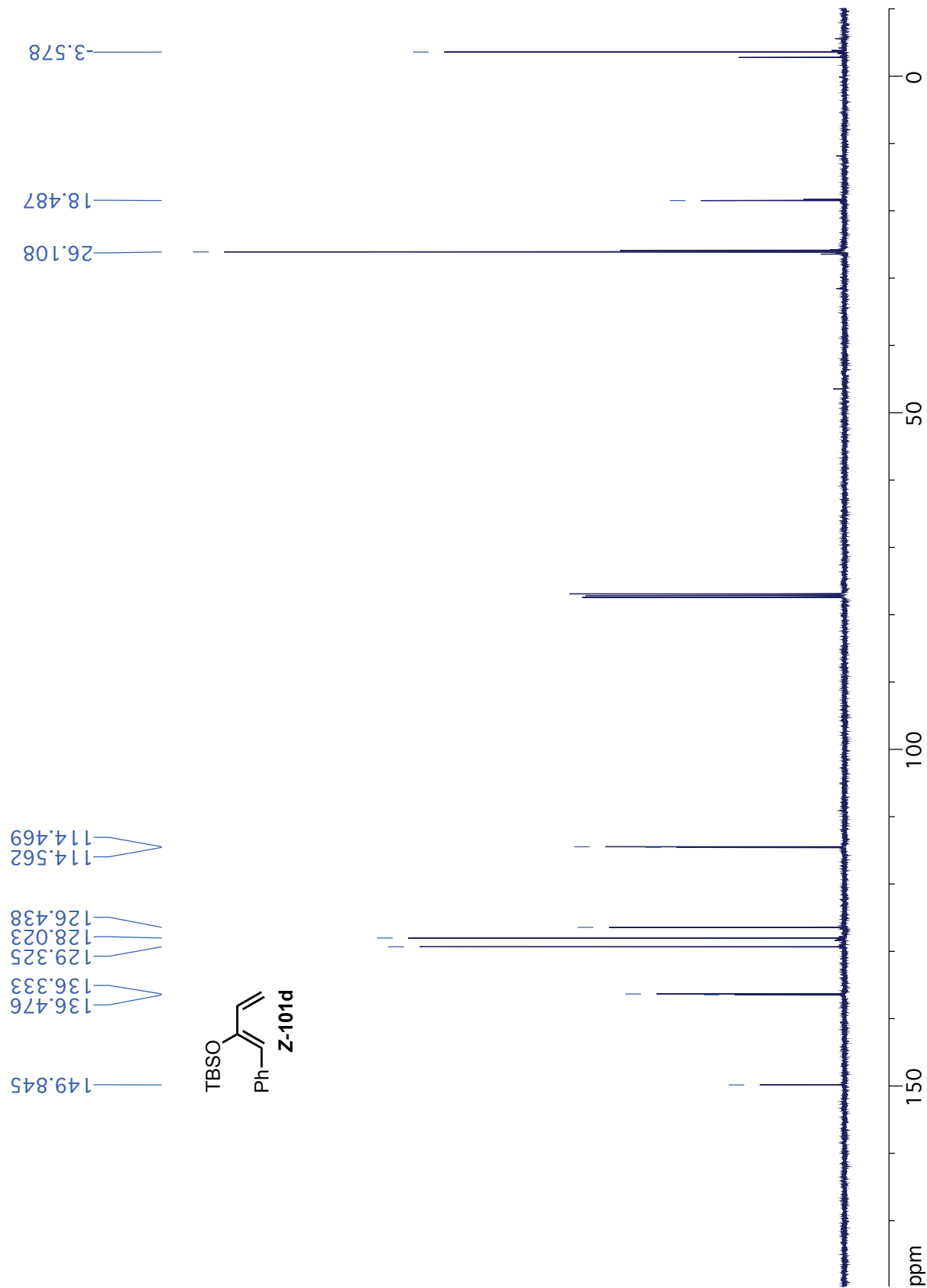

¹H NMR (CDCl₃, 500 MHz): (2Z,4E)-3-(*tert*-Butyldimethylsilyloxy)-2,4-hexadiene (101i)

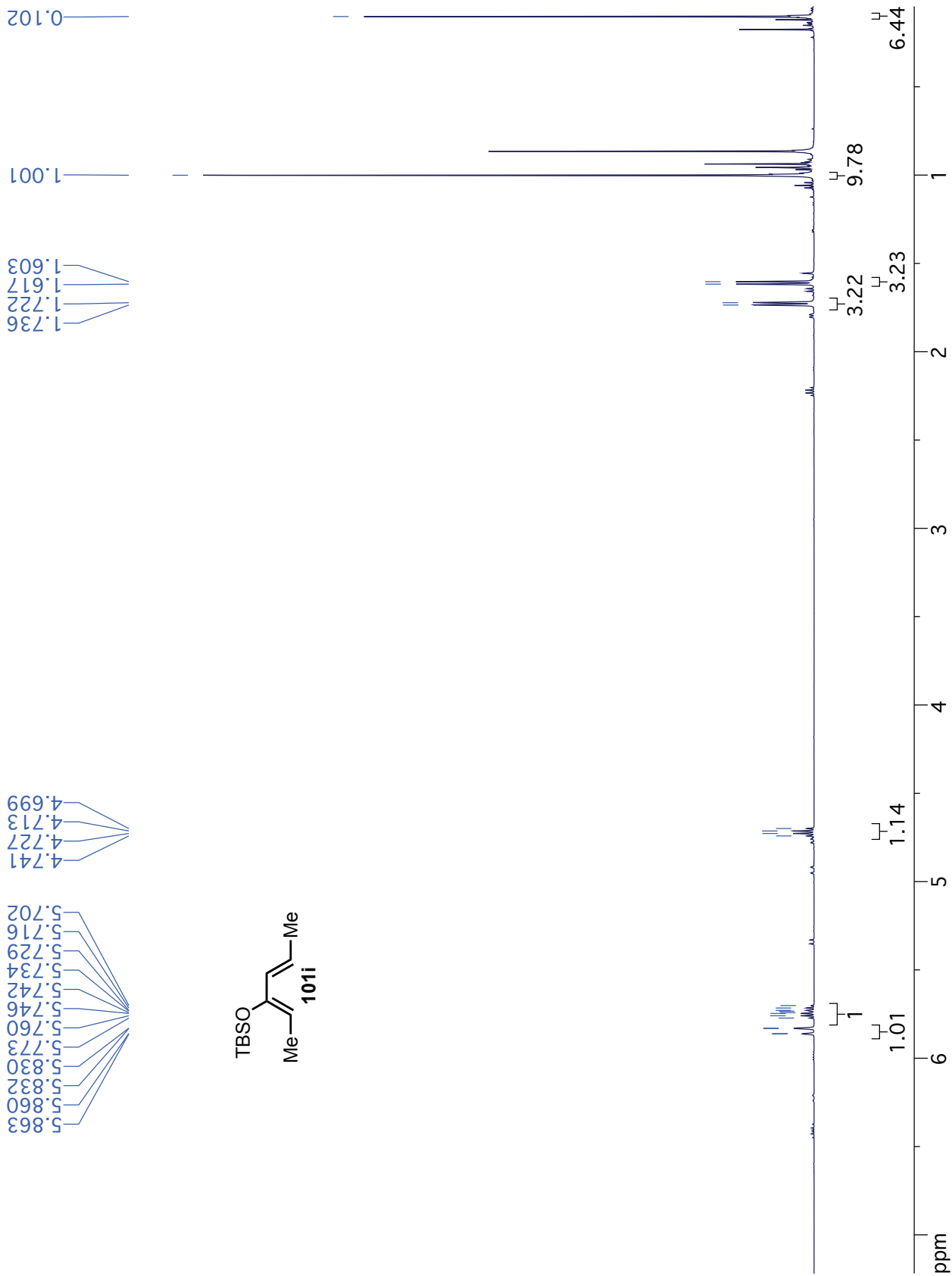

¹³C NMR (CDCl₃, 126 MHz): (2Z,4E)-3-(*tert*-Butyldimethylsilyloxy)-2,4-hexadiene (101i)

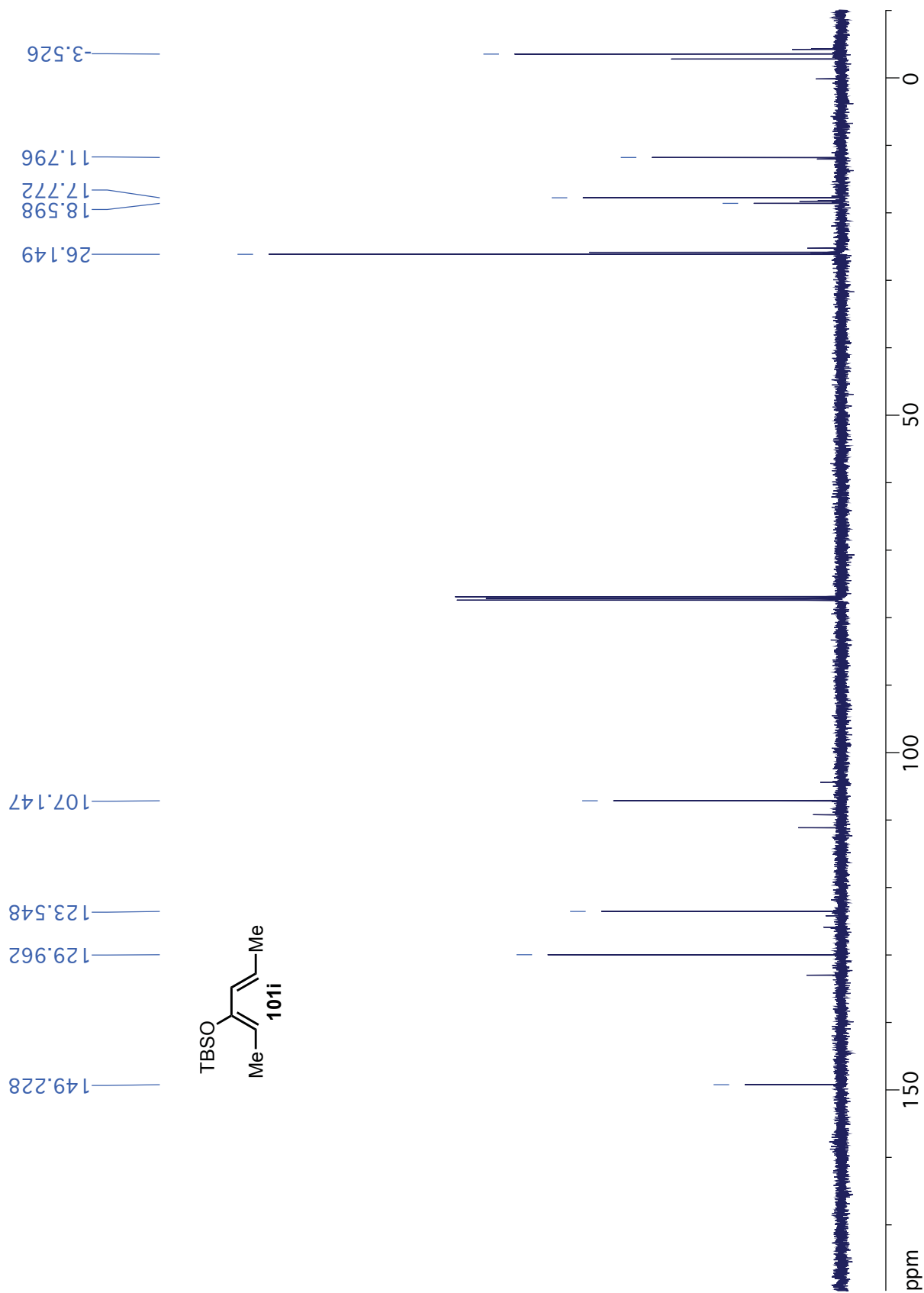

¹H NMR (CDCl₃, 500 MHz): (1*R**,6*S**,7*S**)-1-Methyl-8-methylene-7-phenyl-4-(trimethylsilyloxy)bicyclo[4.2.1]non-3-en-9-one (102)

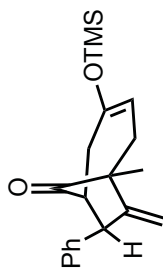
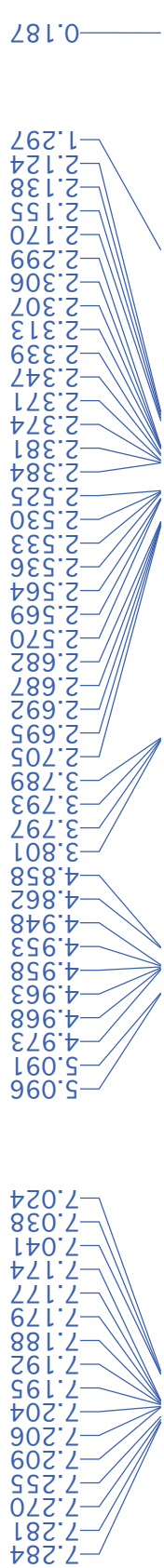

102

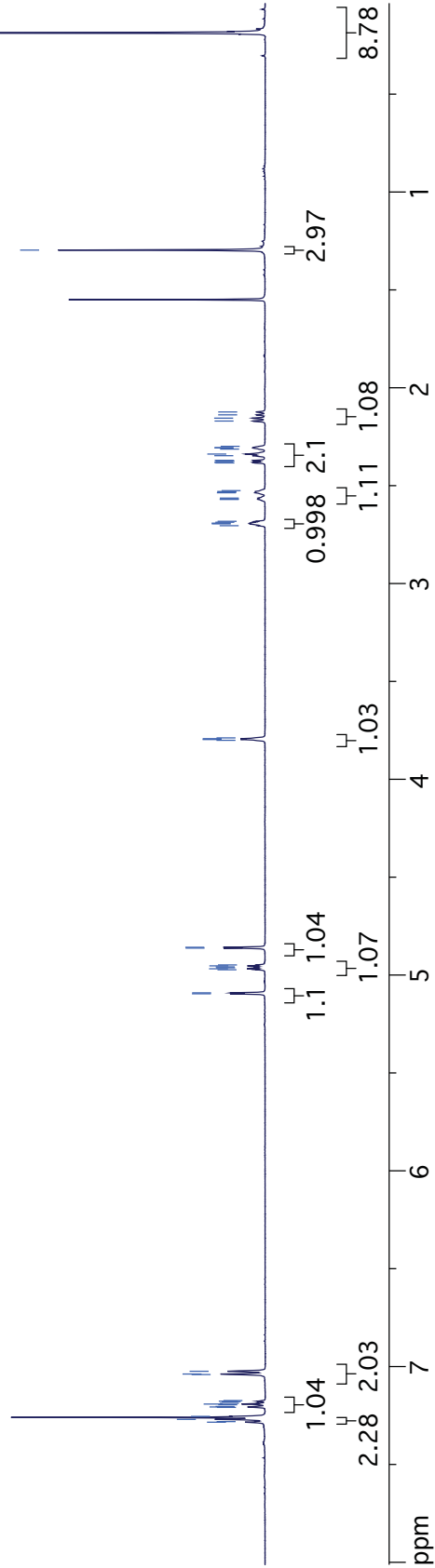

¹³C NMR (CDCl₃, 126 MHz): (1*R**,6*S**,7*S**)-1-Methyl-8-methylene-7-phenyl-4-(trimethylsilyloxy)bicyclo[4.2.1]non-3-en-9-one (102)

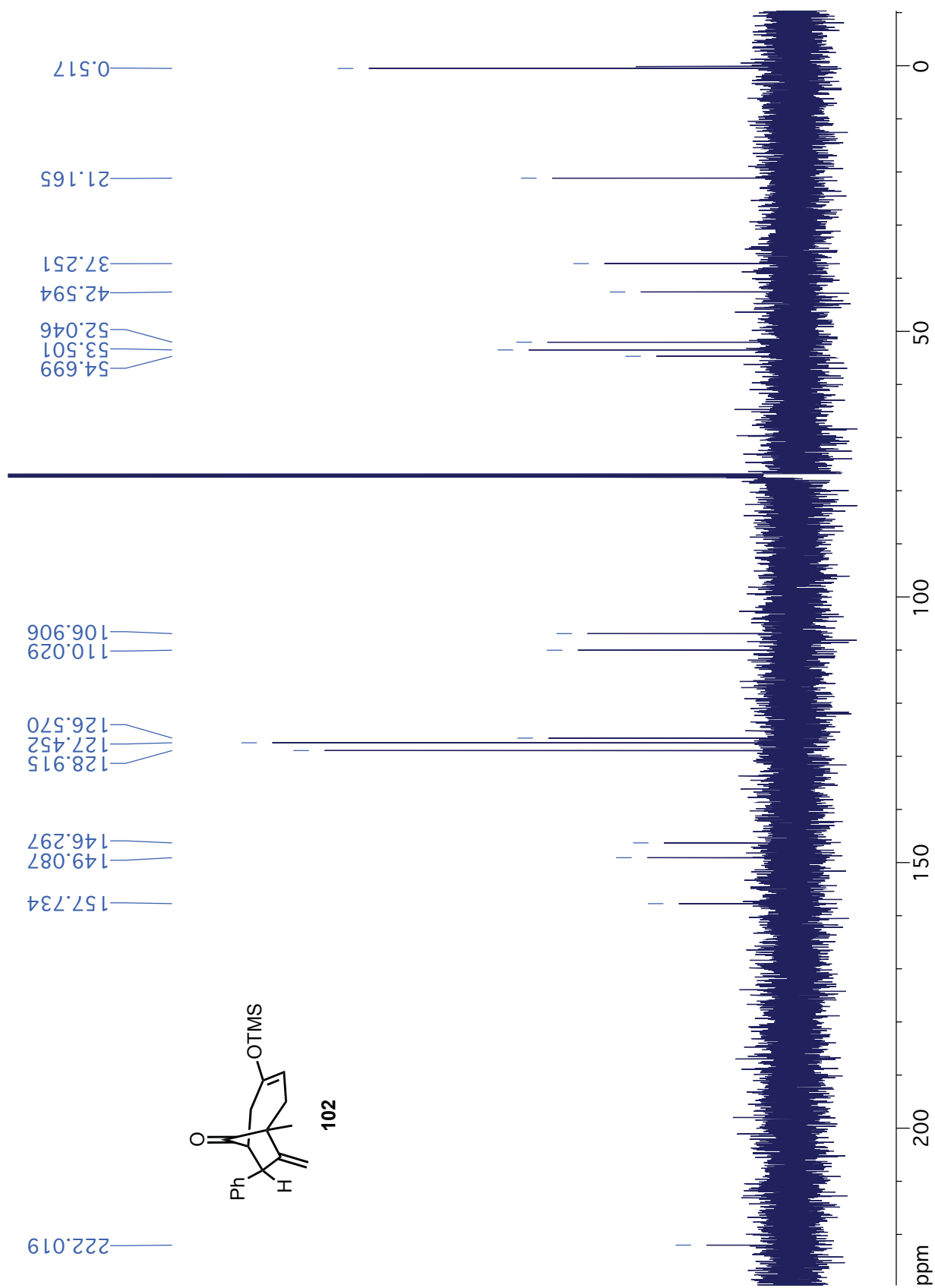

¹H NMR (CDCl₃, 500 MHz): (1*R,6*S**,7*S**)-1-Methyl-8-methylene-7-phenylbicyclo[4.2.1]nonane-4,9-dione (103)**

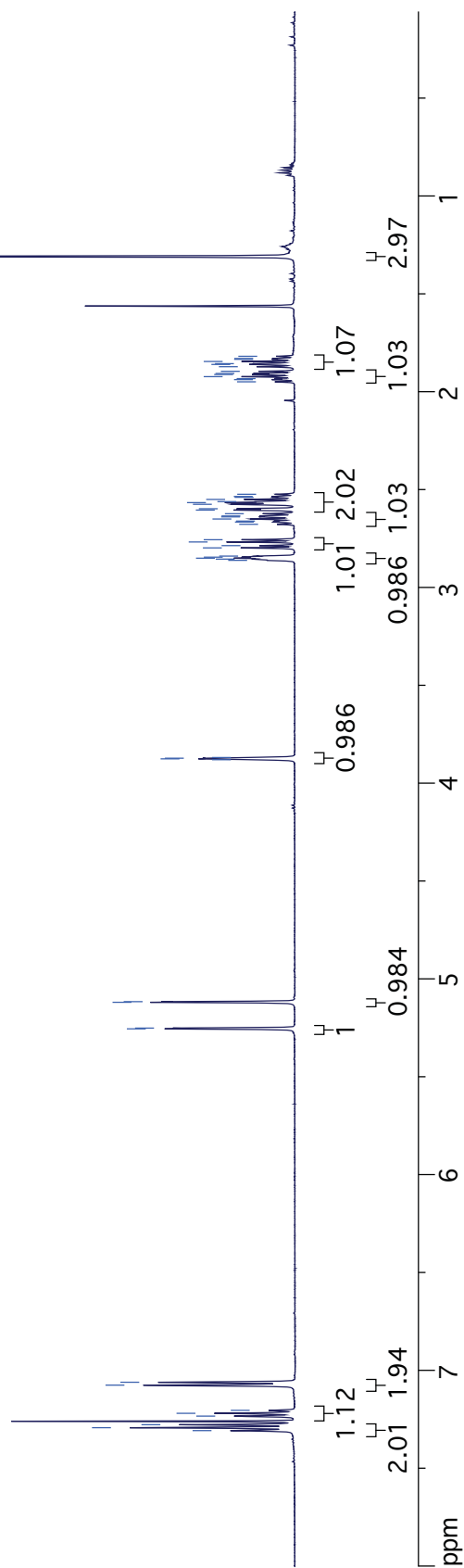
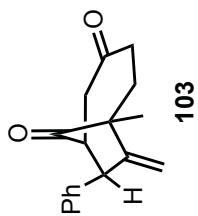
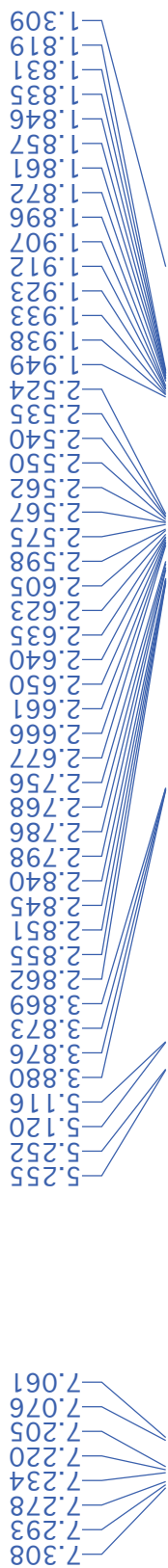

¹³C NMR (CDCl₃, 126 MHz): (1*R**,6*S**,7*S**)-1-Methyl-8-methylene-7-phenylbicyclo[4.2.1]nonane-4,9-dione (103)

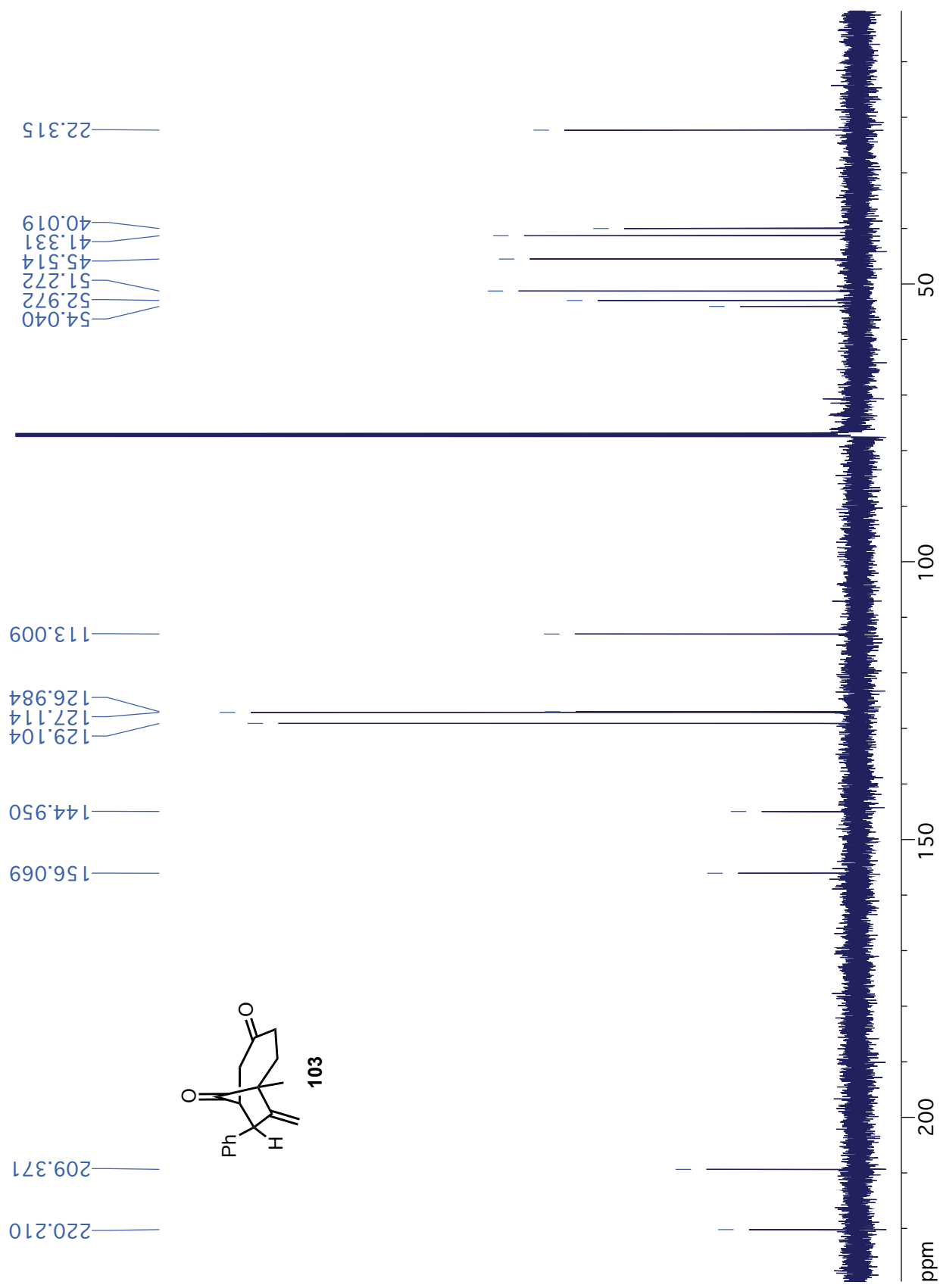

¹H NMR (CDCl₃, 500 MHz): (1*R,2*R**,6*S**,7*S**)-1,2-Dimethyl-8-methylene-7-phenyl-4-(trimethylsilyloxy)bicyclo[4.2.1]non-3-en-9-one (104)**

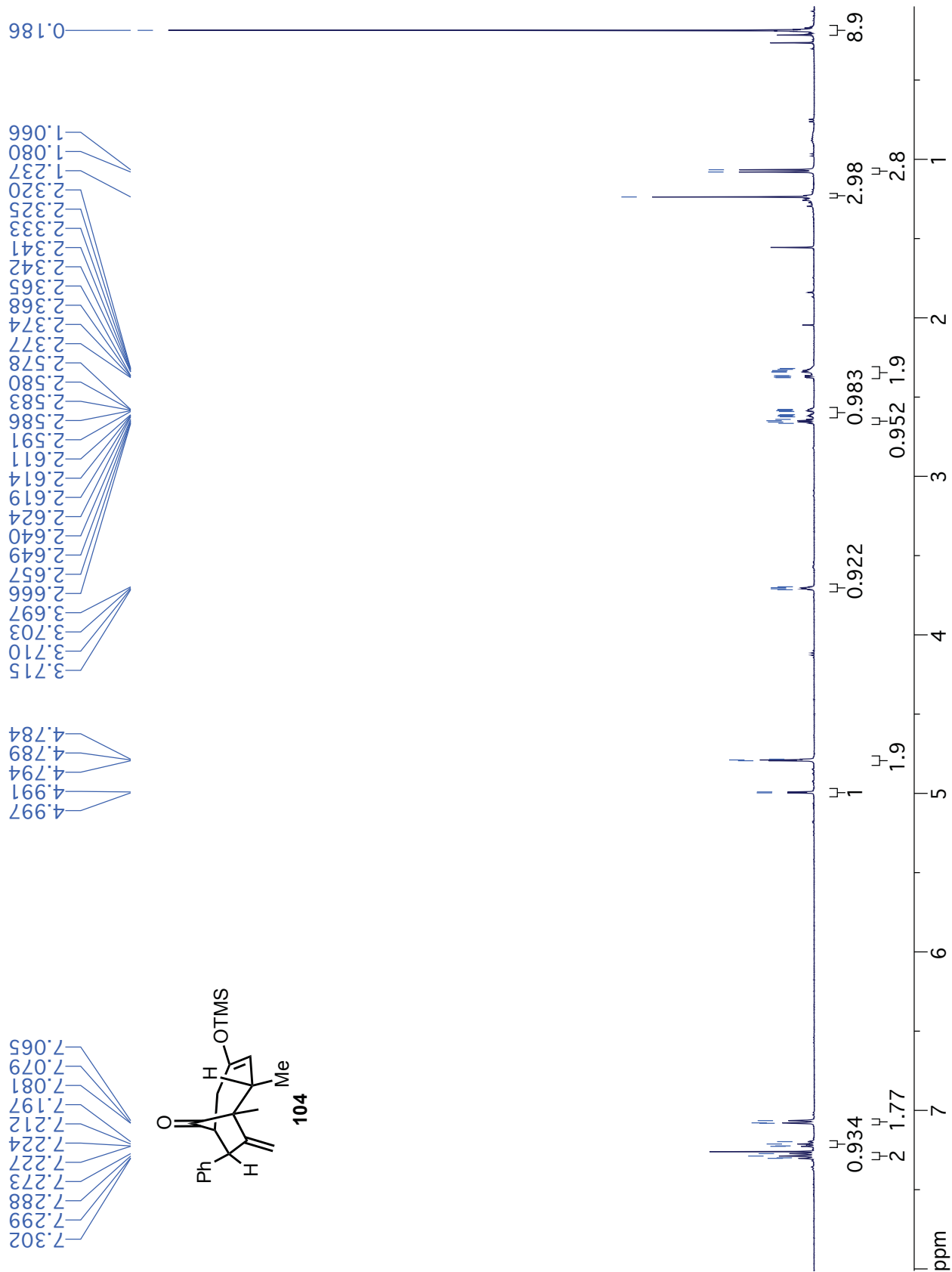

¹³C NMR (CDCl₃, 126 MHz): (1*R**, 2*R**, 6*S**, 7*S**)-1,2-Dimethyl-8-methylene-7-phenyl-4-(trimethylsilyloxy)bicyclo[4.2.1]non-3-en-9-one (104)

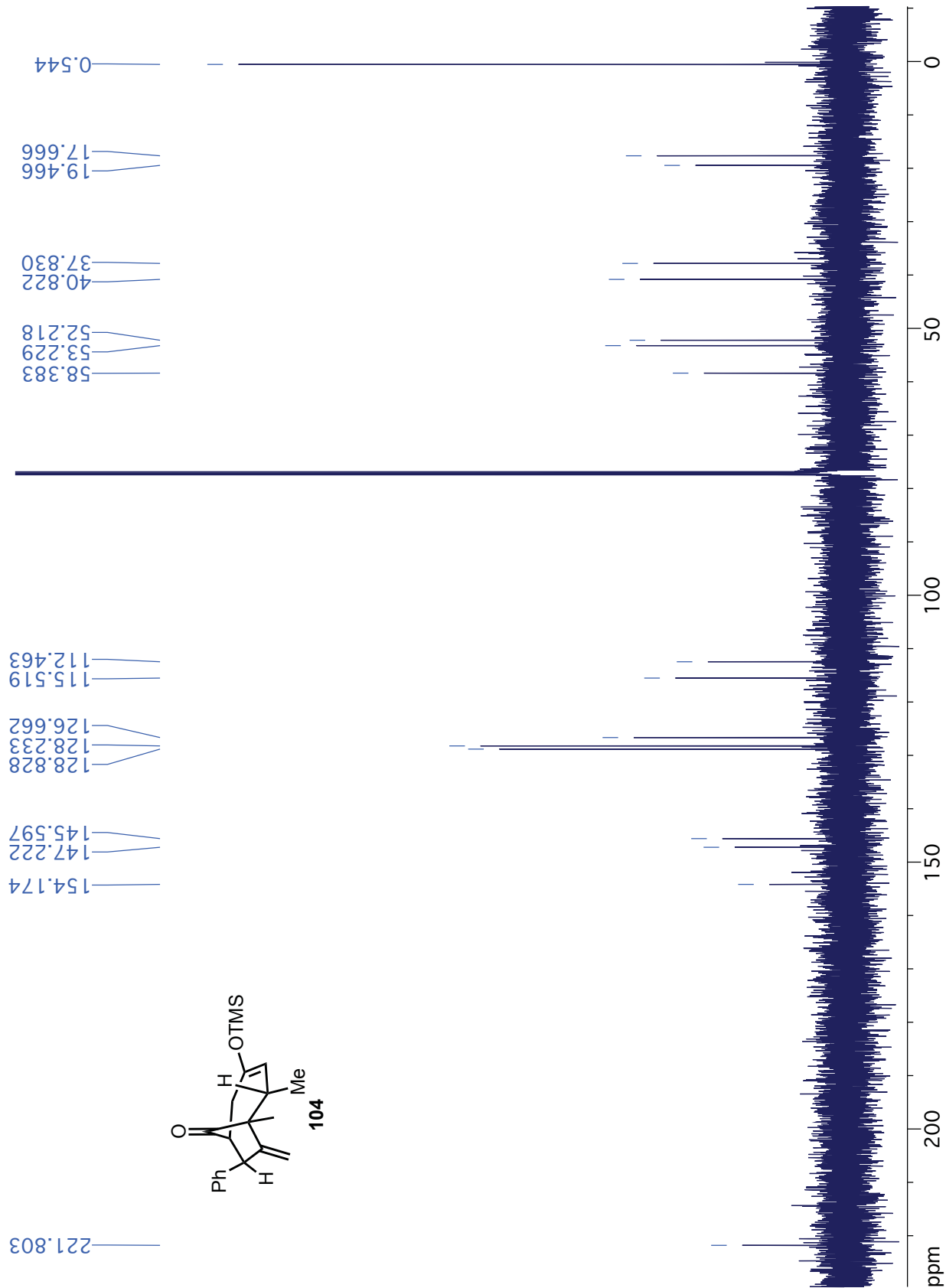

¹H NMR (CDCl₃, 500 MHz): (1*R,2*R**,6*S**,7*S**)-1,2-Dimethyl-8-methylene-7-phenylbicyclo[4.2.1]nonane-4,9-dione (105)**

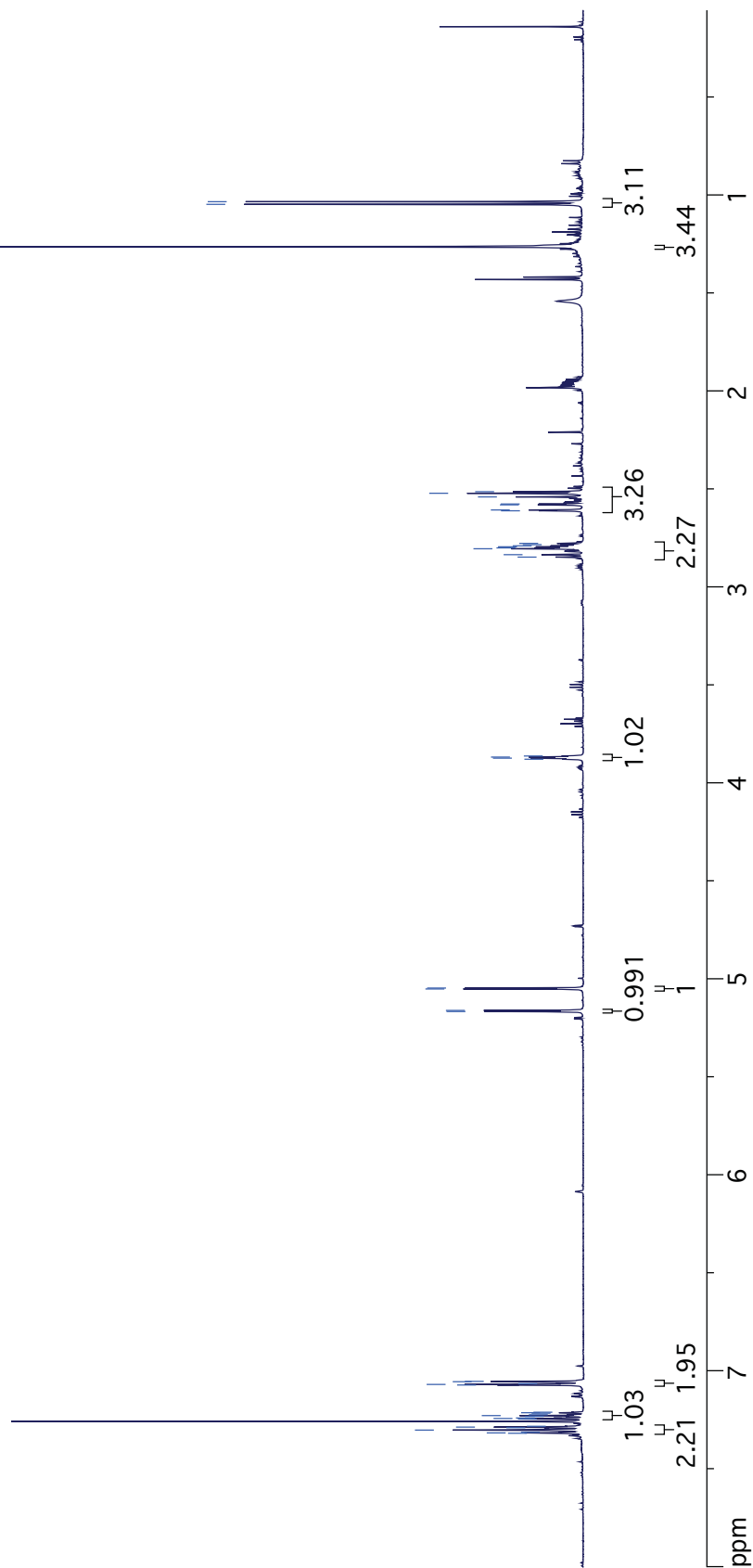
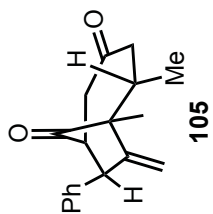
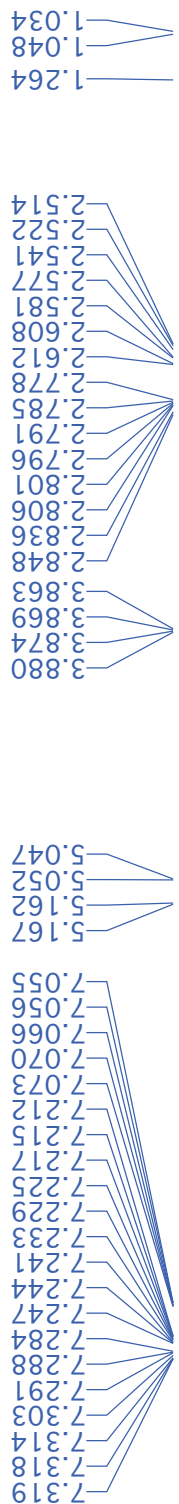

¹³C NMR (CDCl₃, 126 MHz): (1*R, 2*R**, 6*S**, 7*S**)-1,2-Dimethyl-8-methylene-7-phenylbicyclo[4.2.1]nonane-4,9-dione (105)**

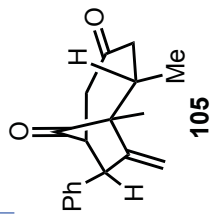
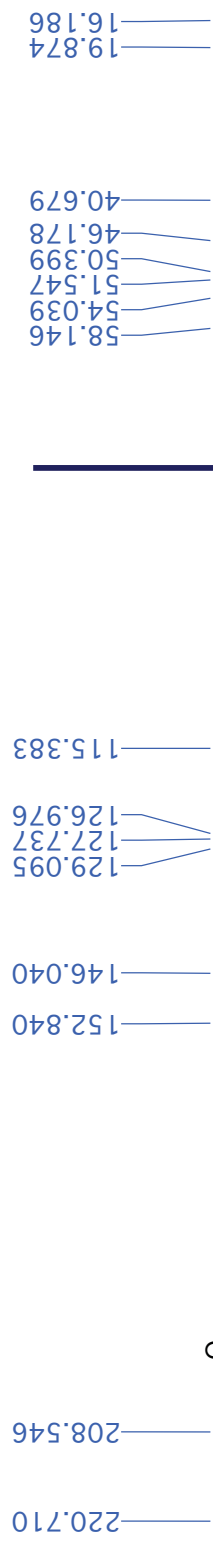

¹H NMR (CDCl₃, 500 MHz): (4*R**, 5*R**)-2,3-Dimethyl-5-((*E*)-2-oxopent-3-en-1-yl)-4-phenylcyclopent-2-enone (106)

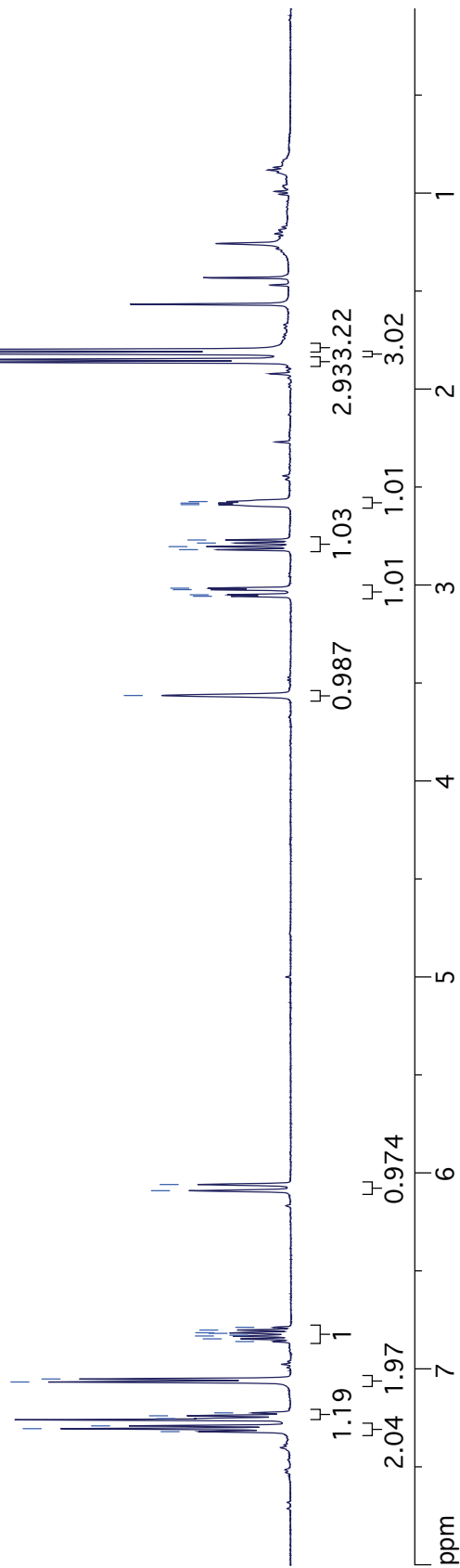
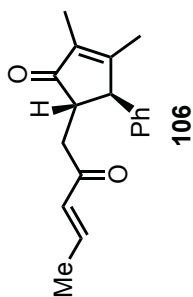

^{13}C NMR (CDCl_3 , 126 MHz): (4*R**, 5*R**)-2,3-Dimethyl-5-((*E*)-2-oxopent-3-en-1-yl)-4-phenylcyclopent-2-enone (106)

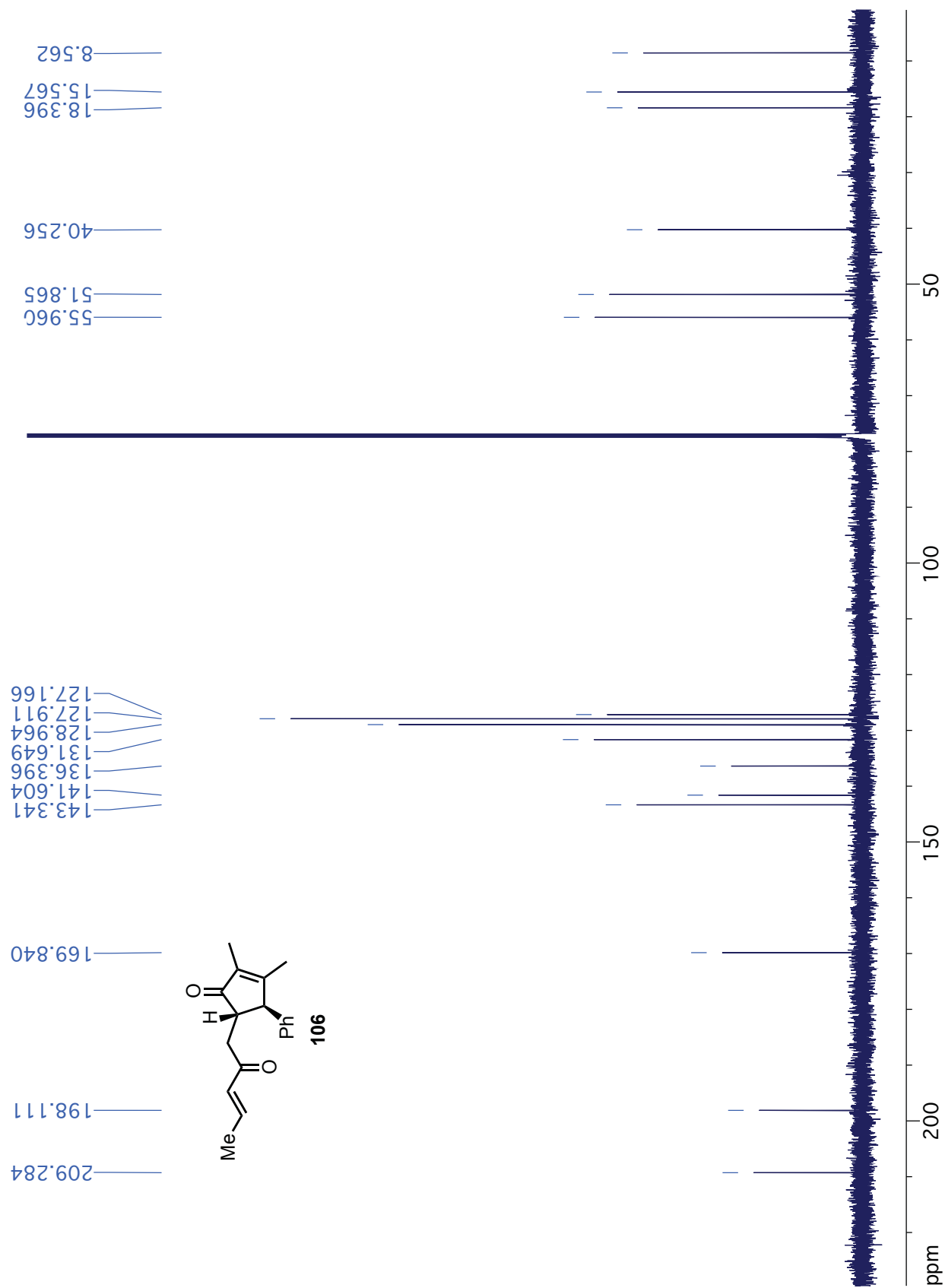

¹H NMR (CDCl₃, 500 MHz): (1*R**, 5*S**, 6*S**, 7*S**)-1,5-Dimethyl-8-methylene-7-phenyl-4-(trimethylsilyloxy)bicyclo[4.2.1]non-3-en-9-one (107a)

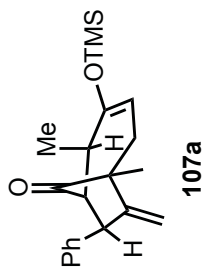
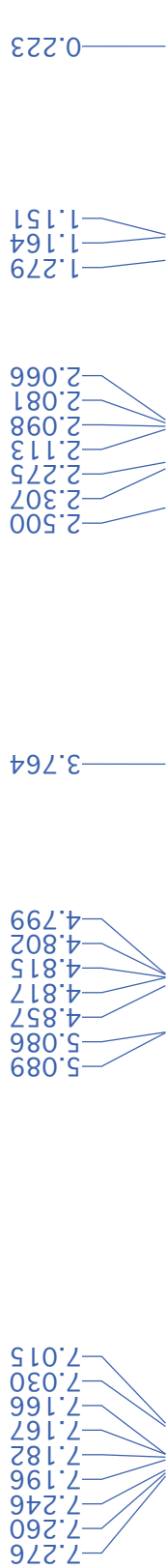

107a

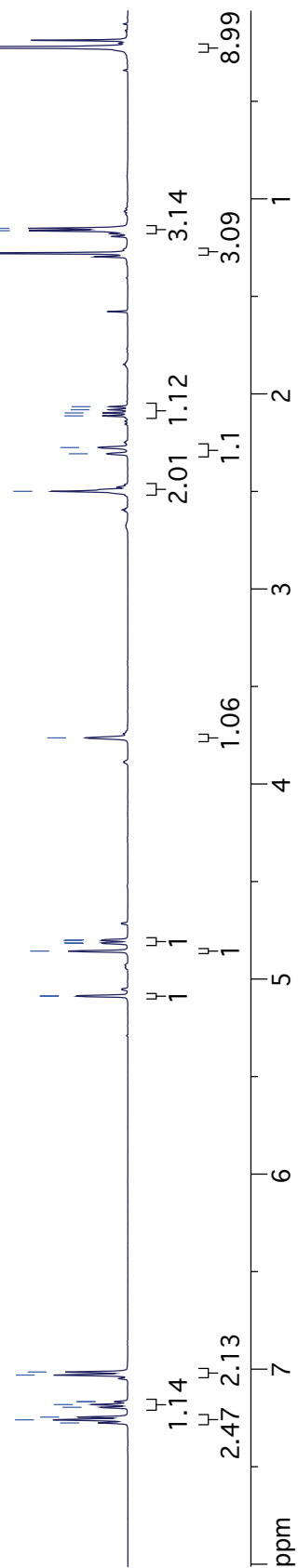

¹³C NMR (CDCl₃, 126 MHz): (1R*,5S*,6S*,7S*)-1,5-Dimethyl-8-methylene-7-phenyl-4-(trimethylsilyloxy)bicyclo[4.2.1]non-3-en-9-one (107a)

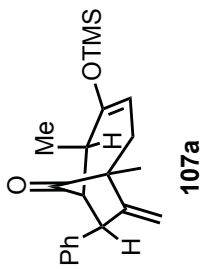
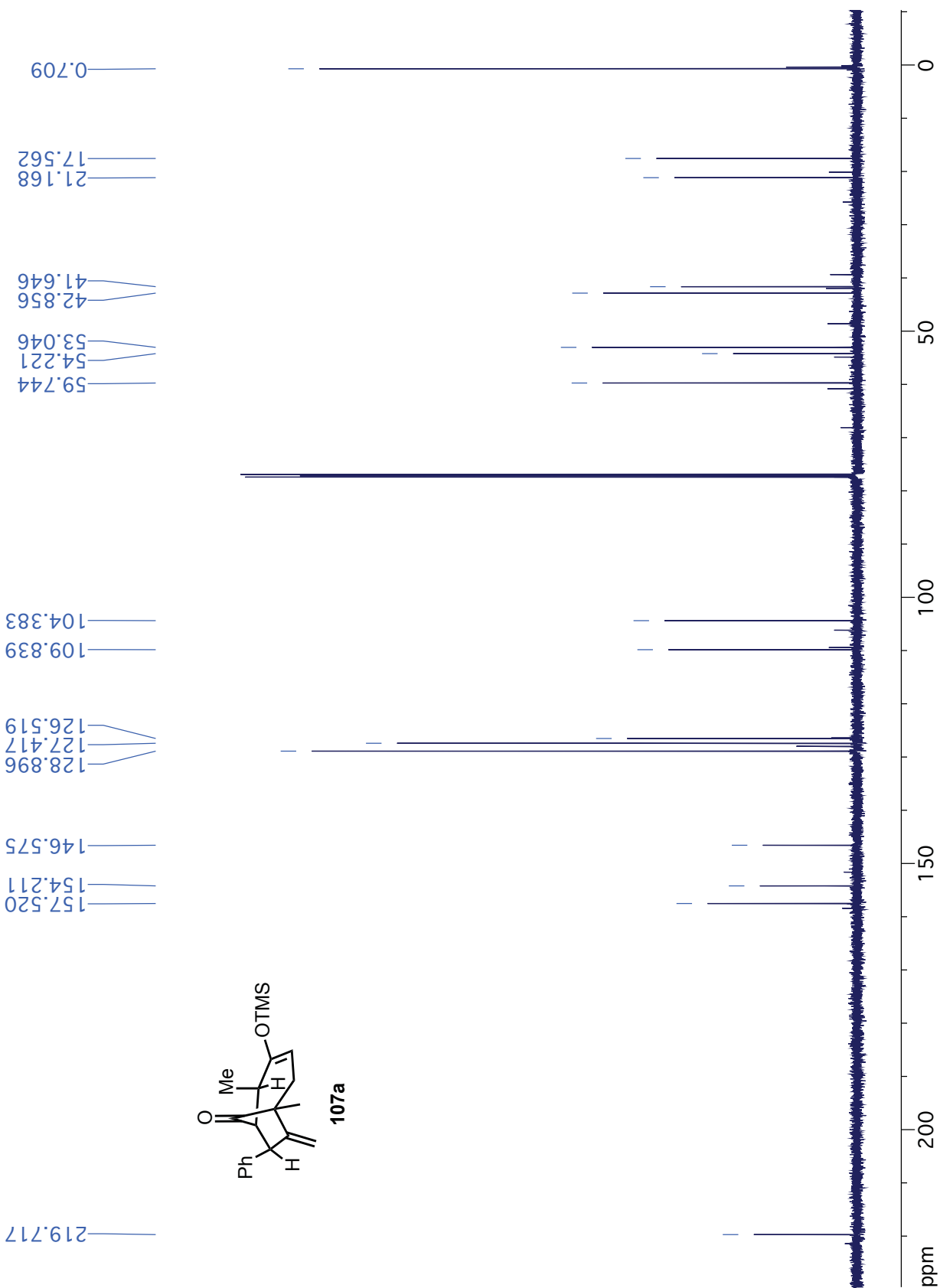

¹H NMR (CDCl₃, 500 MHz): (1*R**, 5*R**, 6*S**, 7*S**)-1,5-Dimethyl-8-methylene-7-phenyl-4-(trimethylsilyloxy)bicyclo[4.2.1]non-3-en-9-one (107b)

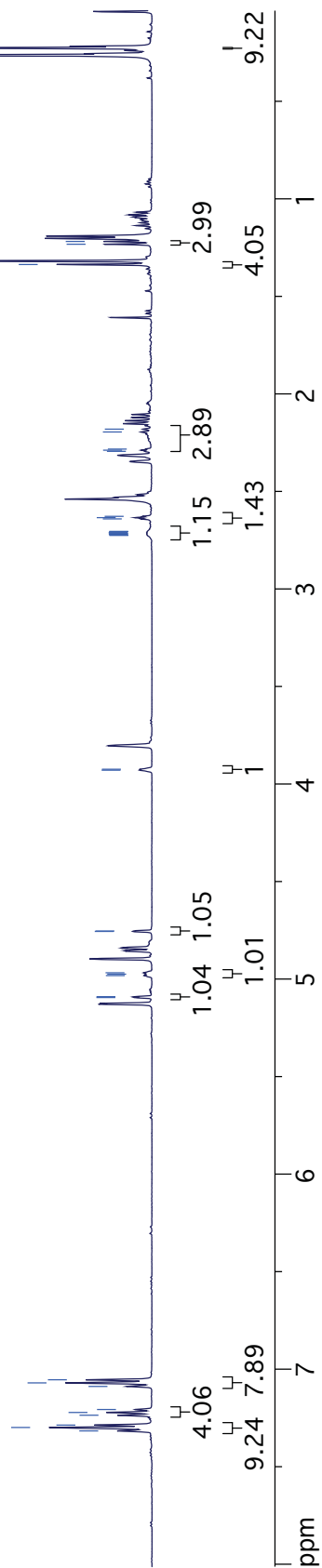
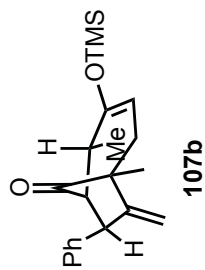
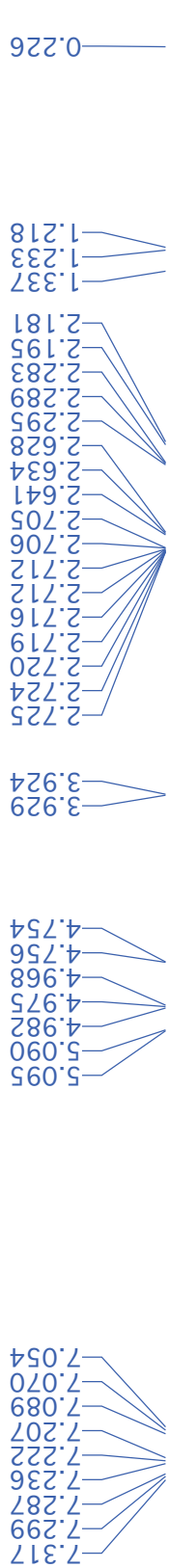

^{13}C NMR (CDCl_3 , 126 MHz): (IR: $5R^*$, $6S^*$, $7S^*$)-1,5-Dimethyl-8-methylene-7-phenyl-4-(trimethylsilyloxy)bicyclo[4.2.1]non-3-en-9-one (107b)

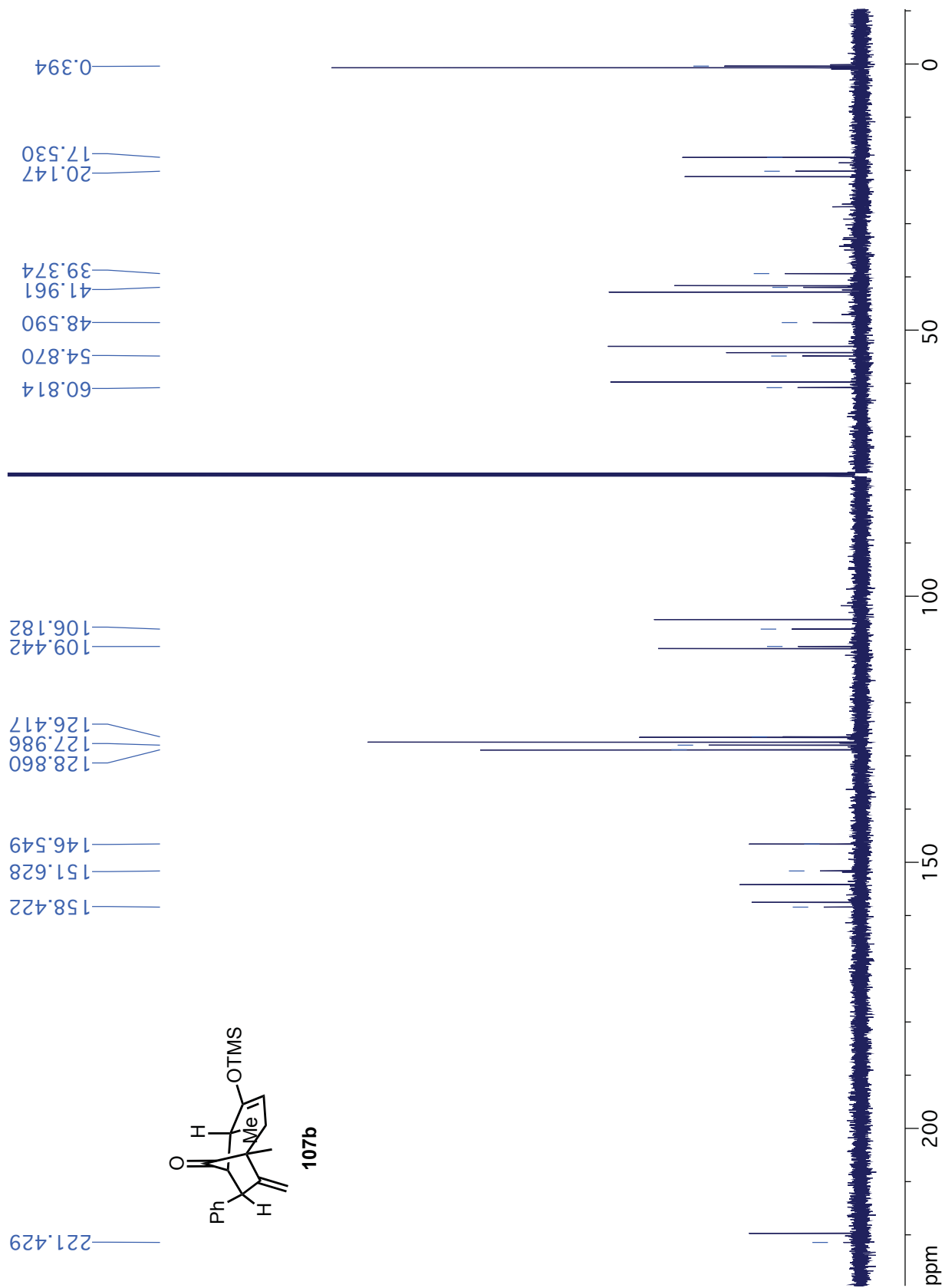

¹³C NMR (CDCl₃, 126 MHz): (1*R**,5*S**,6*S**,7*S**)-1,5-Dimethyl-8-methylene-7-phenylbicyclo[4.2.1]nonane-4,9-dione (108a) and (1*R**,5*R**,6*S**,7*S**)-1,5-dimethyl-8-methylene-7-phenylbicyclo[4.2.1]nonane-4,9-dione (108b)

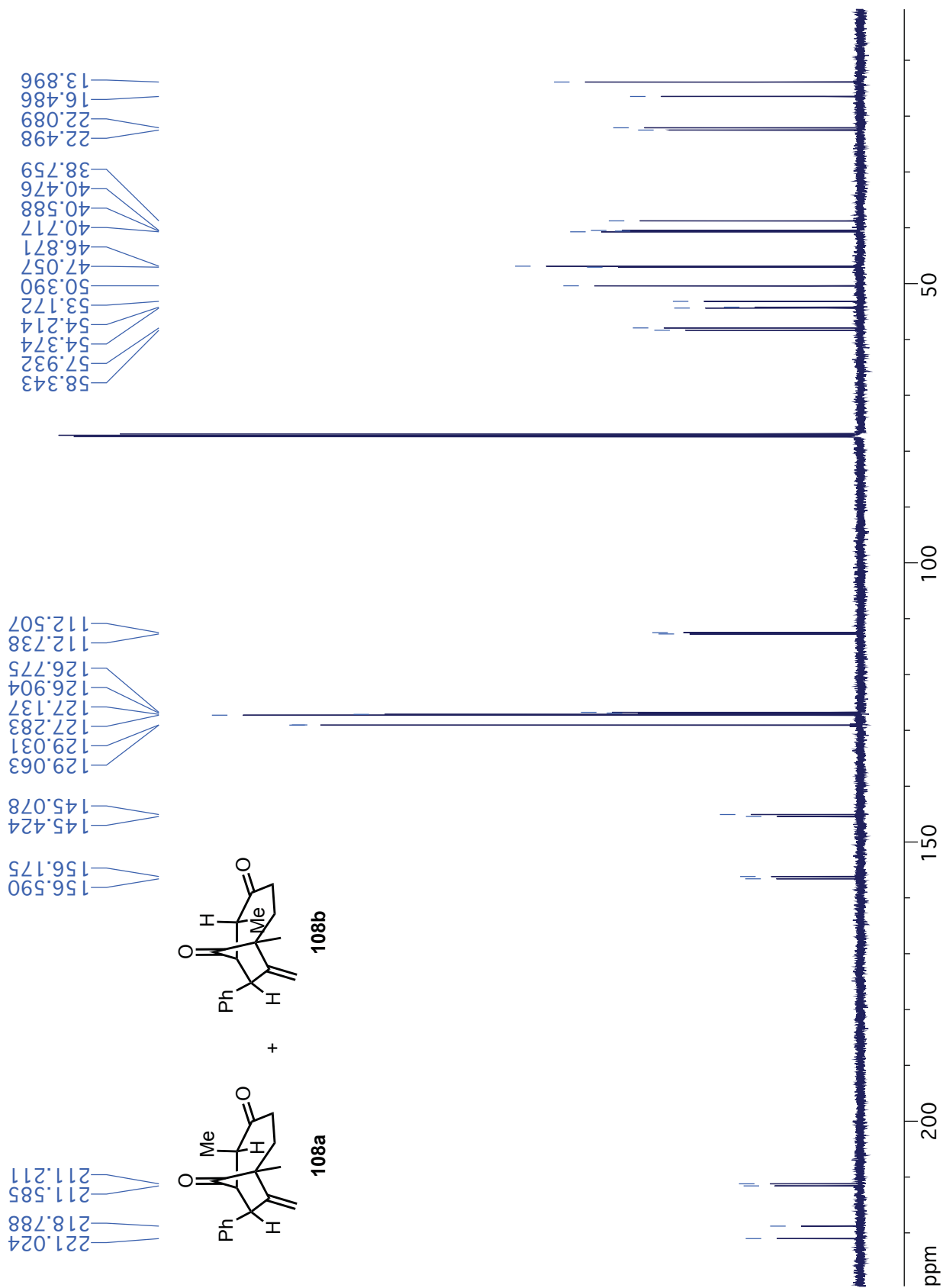

¹³C NMR (CDCl₃, 126 MHz): (1R*,5S*,6S*,7S*)-4-(*tert*-Butyldimethylsilyloxy)-1,5-dimethyl-8-methylene-7-phenylbicyclo[4.2.1]non-3-en-9-one (109a)

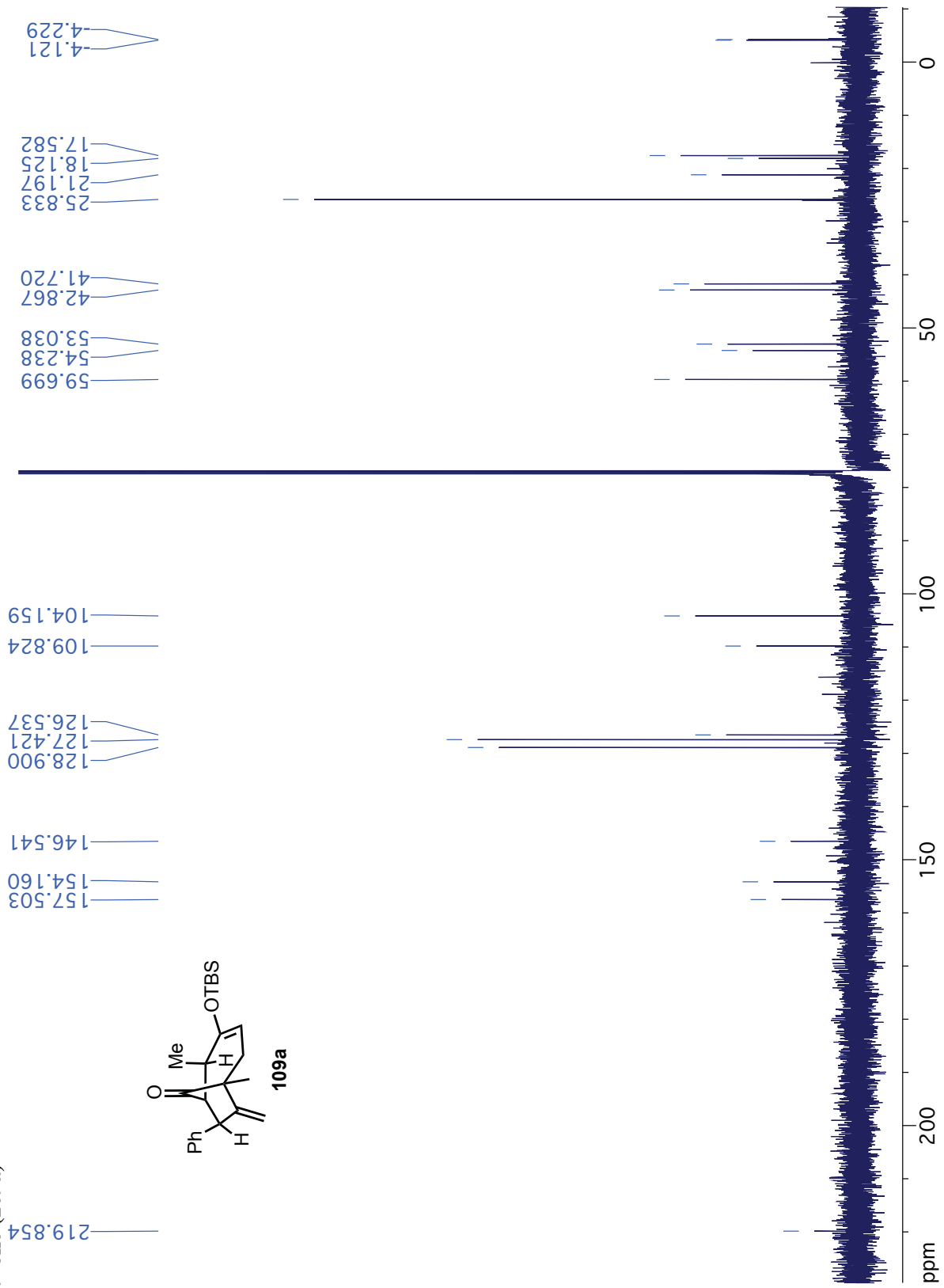

¹H NMR (CDCl₃, 500 MHz): (1*R**,5*R**,6*S**,7*S**)-4-(*tert*-Butyldimethylsilyloxy)-1,5-dimethyl-8-methylene-7-phenylbicyclo[4.2.1]non-3-en-9-one (109b)

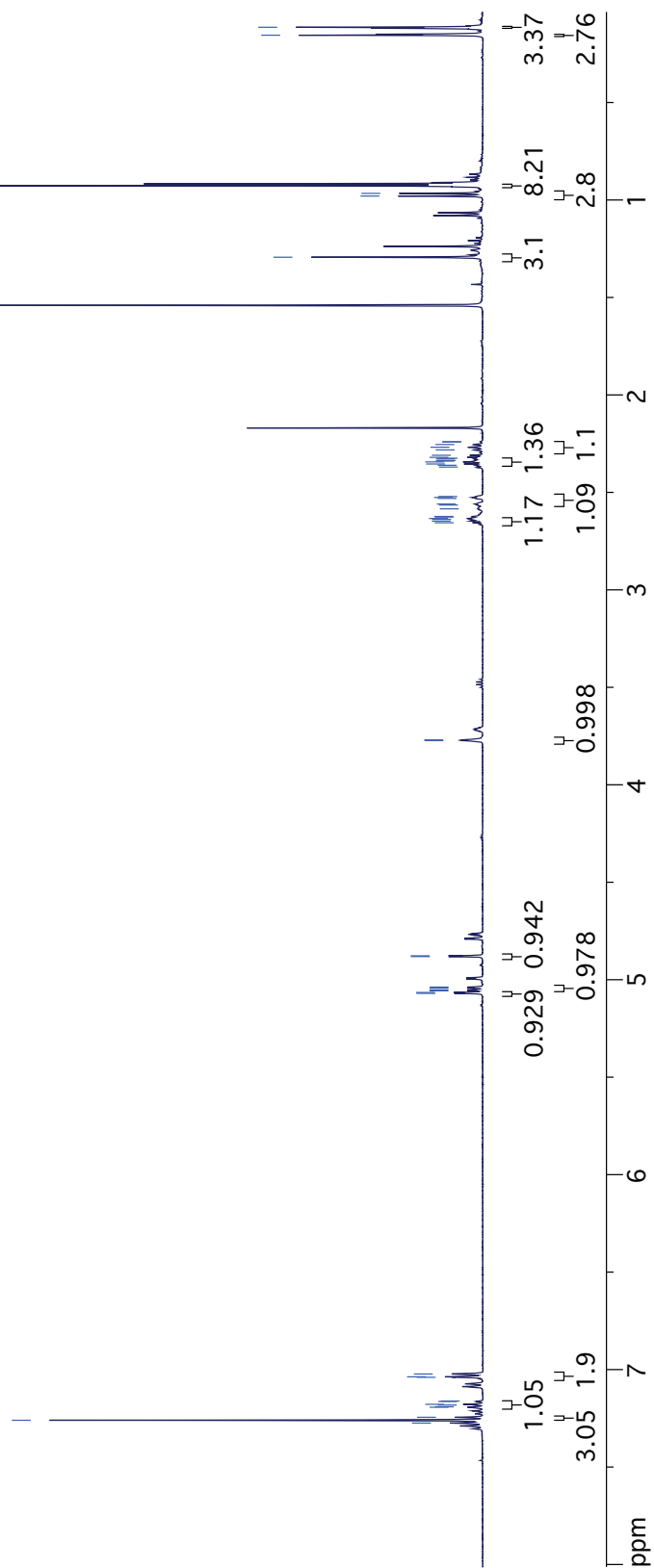
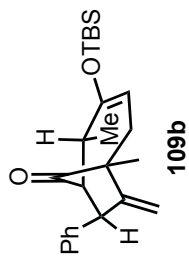
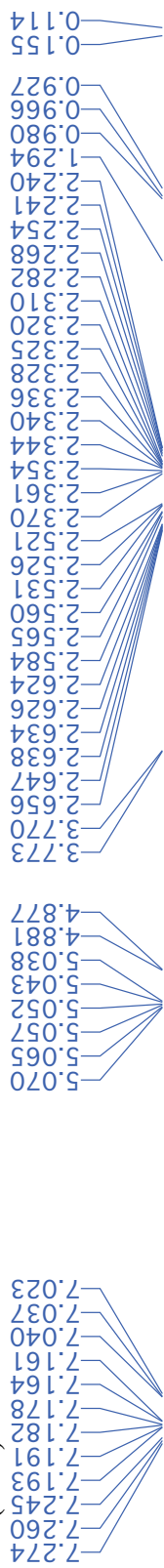

¹³C NMR (CDCl₃, 126 MHz): (1*R**,5*R**,6*S**,7*S**)-4-(*tert*-Butyldimethylsilyloxy)-1,5-dimethyl-8-methylene-7-phenylbicyclo[4.2.1]non-3-en-9-one (109b)

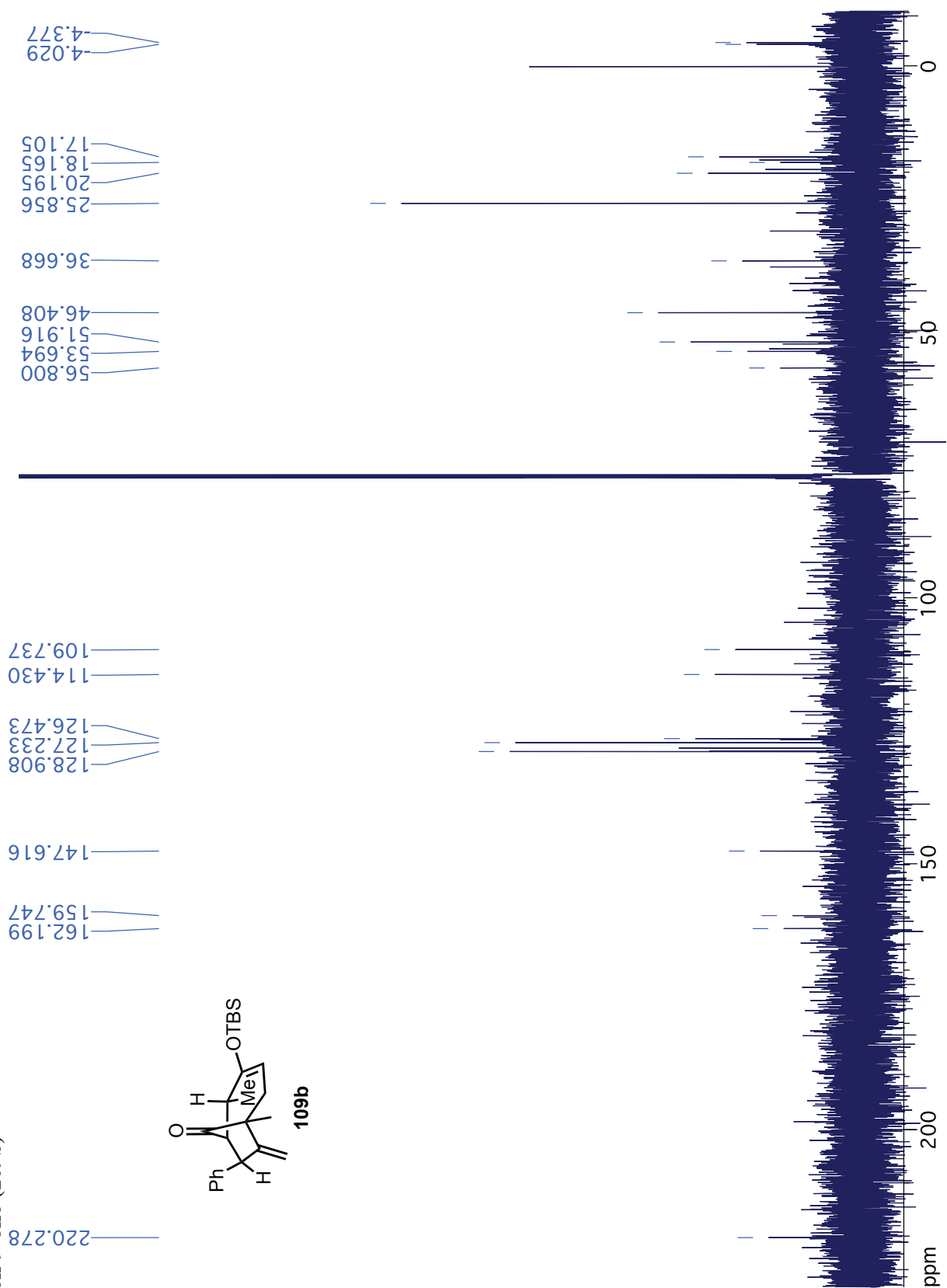
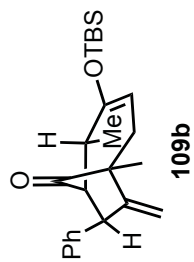

¹H NMR (CDCl₃, 500 MHz): (1*R**, 5*S**, 6*S**, 7*S**)-4-(*tert*-Butyldimethylsilyloxy)-5-ethyl-1-methyl-8-methylene-7-phenylbicyclo[4.2.1]non-3-en-9-one (110a) and (1*R**, 5*R**, 6*S**, 7*S**)-4-(*tert*-butyldimethylsilyloxy)-5-ethyl-1-methyl-8-methylene-7-phenylbicyclo[4.2.1]non-3-en-9-one (110b)

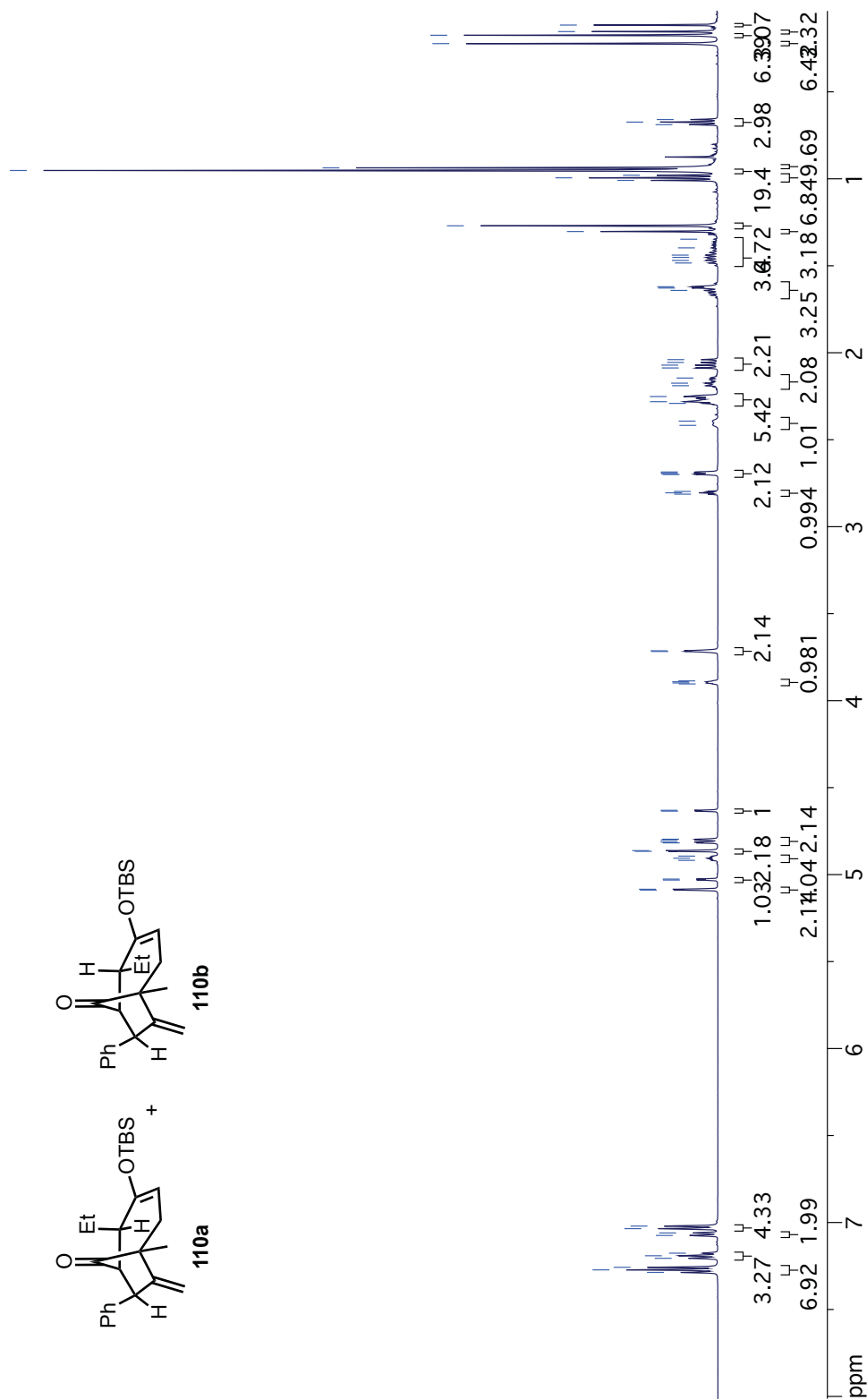
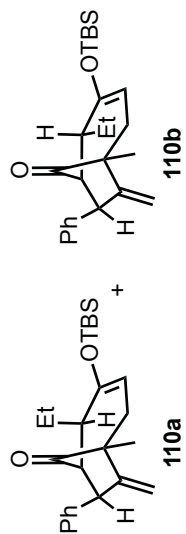
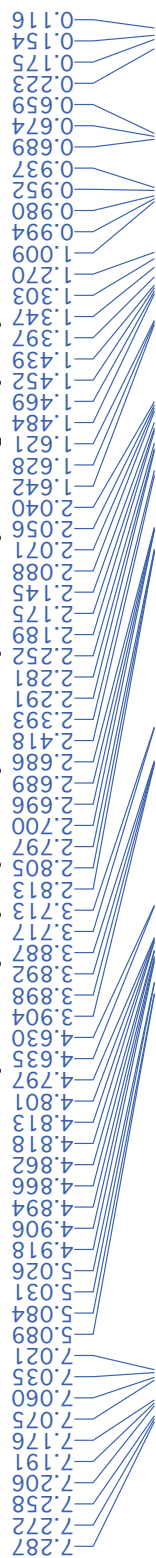

¹³C NMR (CDCl₃, 126 MHz): (1*R**,5*S**,6*S**,7*S**)-4-(*tert*-Butyldimethylsilyloxy)-5-ethyl-1-methyl-8-methylene-7-phenylbicyclo[4.2.1]non-3-en-9-one (110a) and (1*R**,5*R**,6*S**,7*S**)-4-(*tert*-butyldimethylsilyloxy)-5-ethyl-1-methyl-8-methylene-7-phenylbicyclo[4.2.1]non-3-en-9-one (110b)

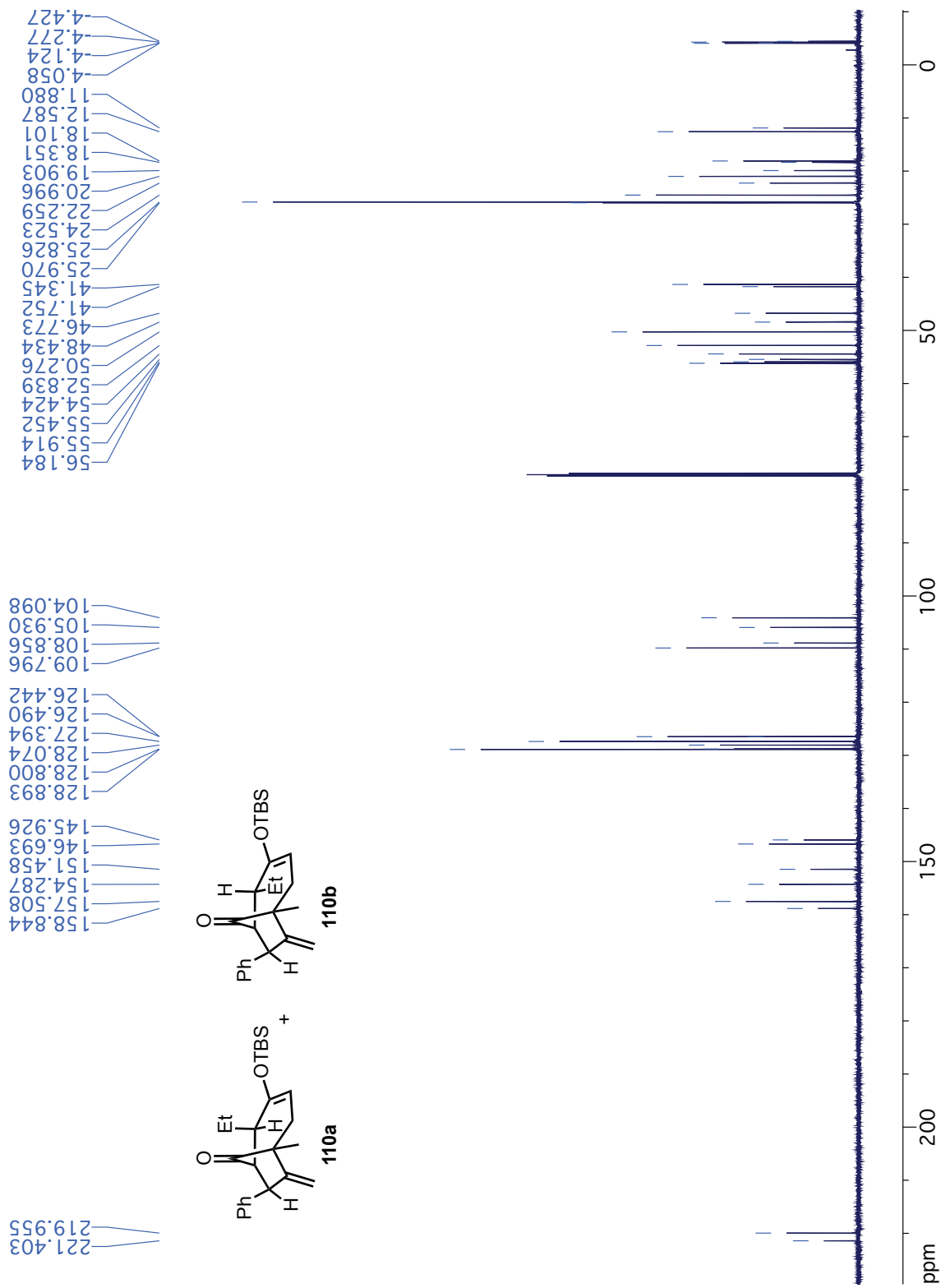

¹H NMR (CDCl₃, 500 MHz): (1*R**, 5*R**, 6*S**, 7*S**)-4-(*tert*-Butyldimethylsilyloxy)-1-methyl-8-methylene-7-phenyl-5-isopropylbicyclo-[4.2.1]non-3-en-9-one (111)

7.266
7.251
7.236
7.186
7.171
7.156
6.998
6.984

4.987
4.980
4.972
4.967
4.959
4.610
3.748
3.738
3.735
2.457
2.450
2.443
2.436
2.429
2.423
2.409
2.386
2.153
2.146
2.141
2.122
2.117
2.110
2.094
2.077
2.063
2.047
1.312
1.298
1.284
1.282
1.259
1.244
1.244
1.240
0.951
0.893
0.880
0.844
0.830
0.214
0.151

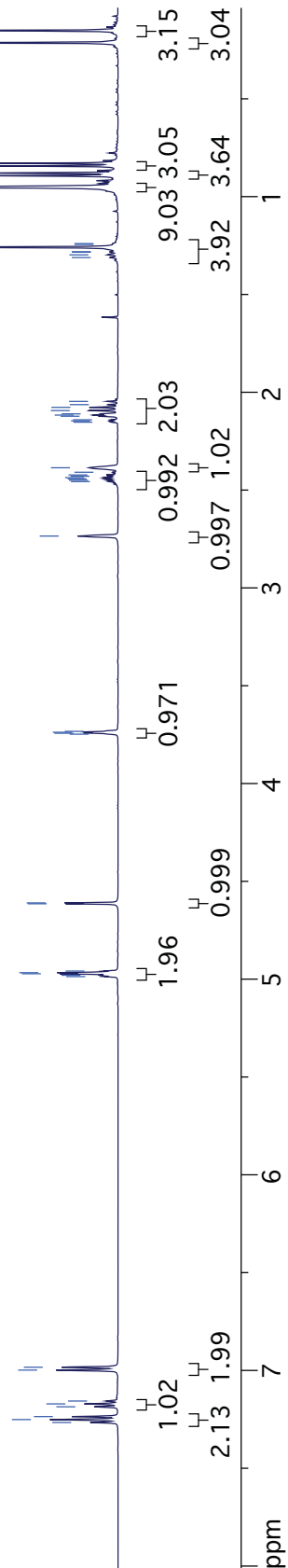
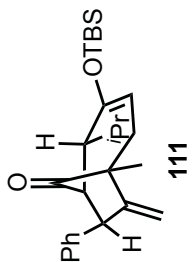

^{13}C NMR (CDCl₃, 126 MHz): (1*R**, 5*R**, 6*S**, 7*S**)-4-(*tert*-Butyldimethylsilyloxy)-1-methyl-8-methylene-7-phenyl-5-isopropylbicyclo-[4.2.1]non-3-en-9-one (111)

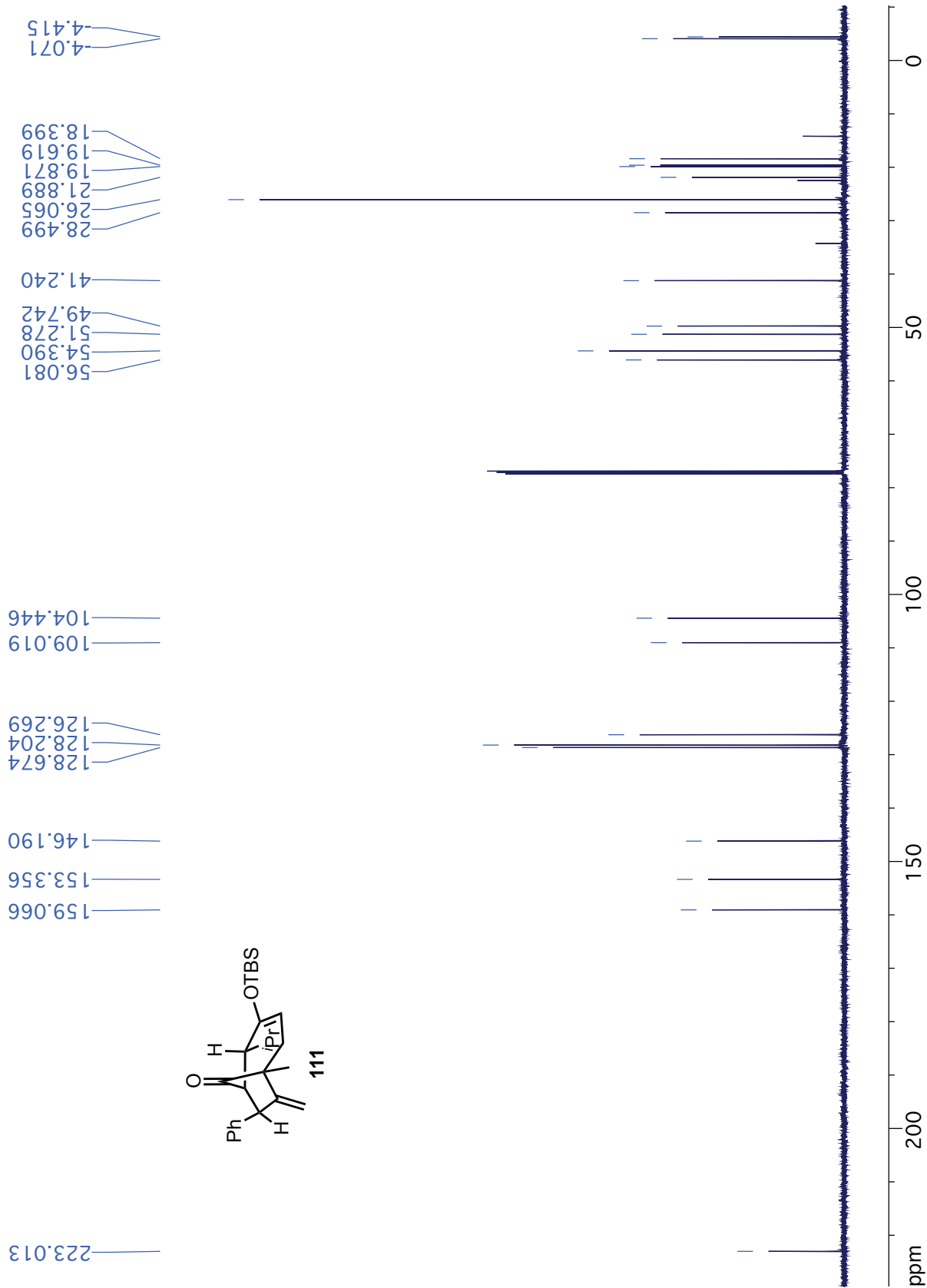

¹H NMR (CDCl₃, 500 MHz): (1*R**,5*S**,6*S**,7*S**)-4-(*tert*-Butyldimethylsilyloxy)-1-methyl-8-methylene-5,7-diphenylbicyclo[4.2.1]non-3-en-9-one (112a)

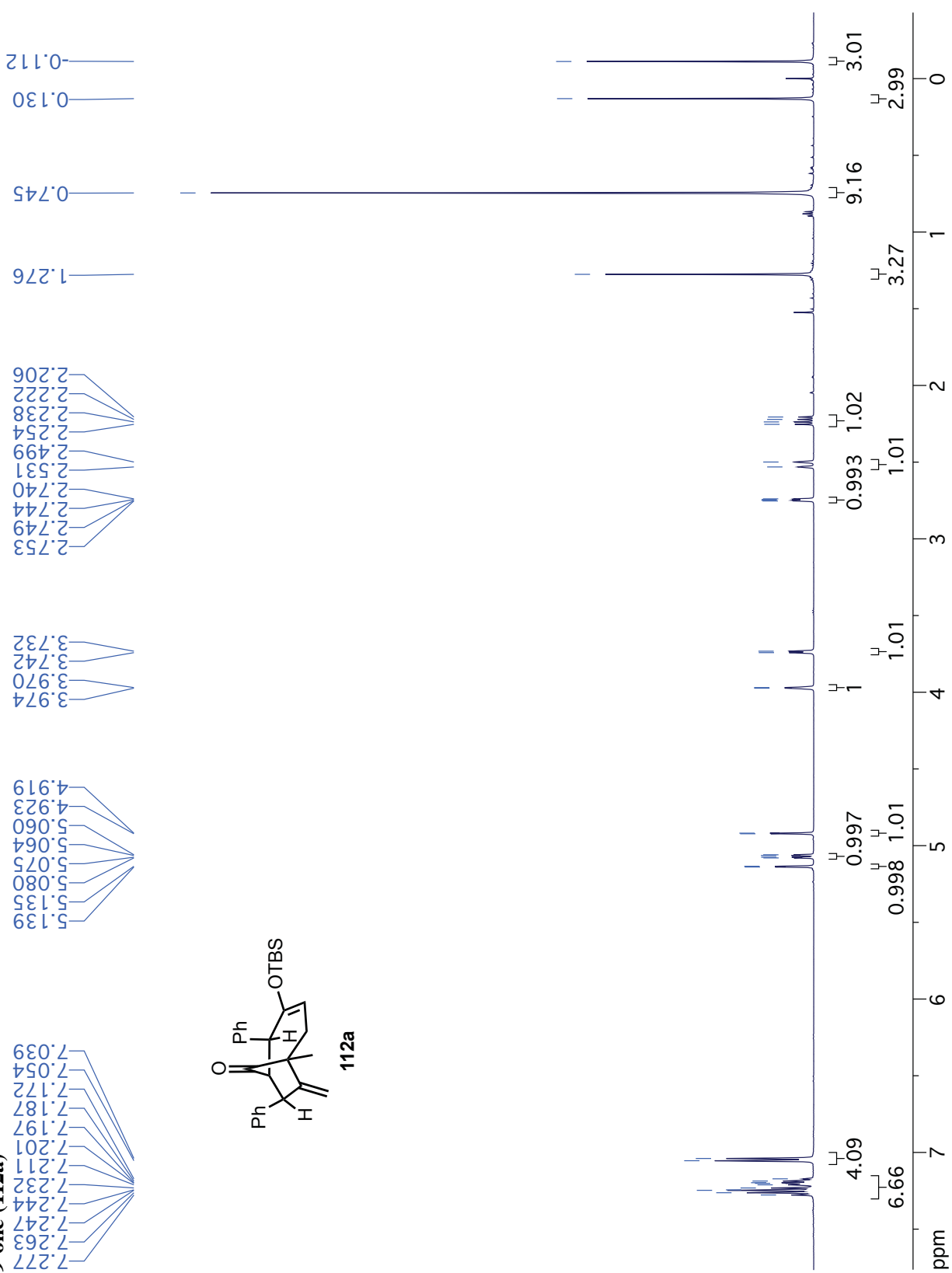

¹³C NMR (CDCl₃, 126 MHz): (1R*,5S*,6S*,7S*)-4-(tert-Butyldimethylsilyloxy)-1-methyl-8-methylene-5,7-diphenylbicyclo[4.2.1]non-3-en-9-one (112a)

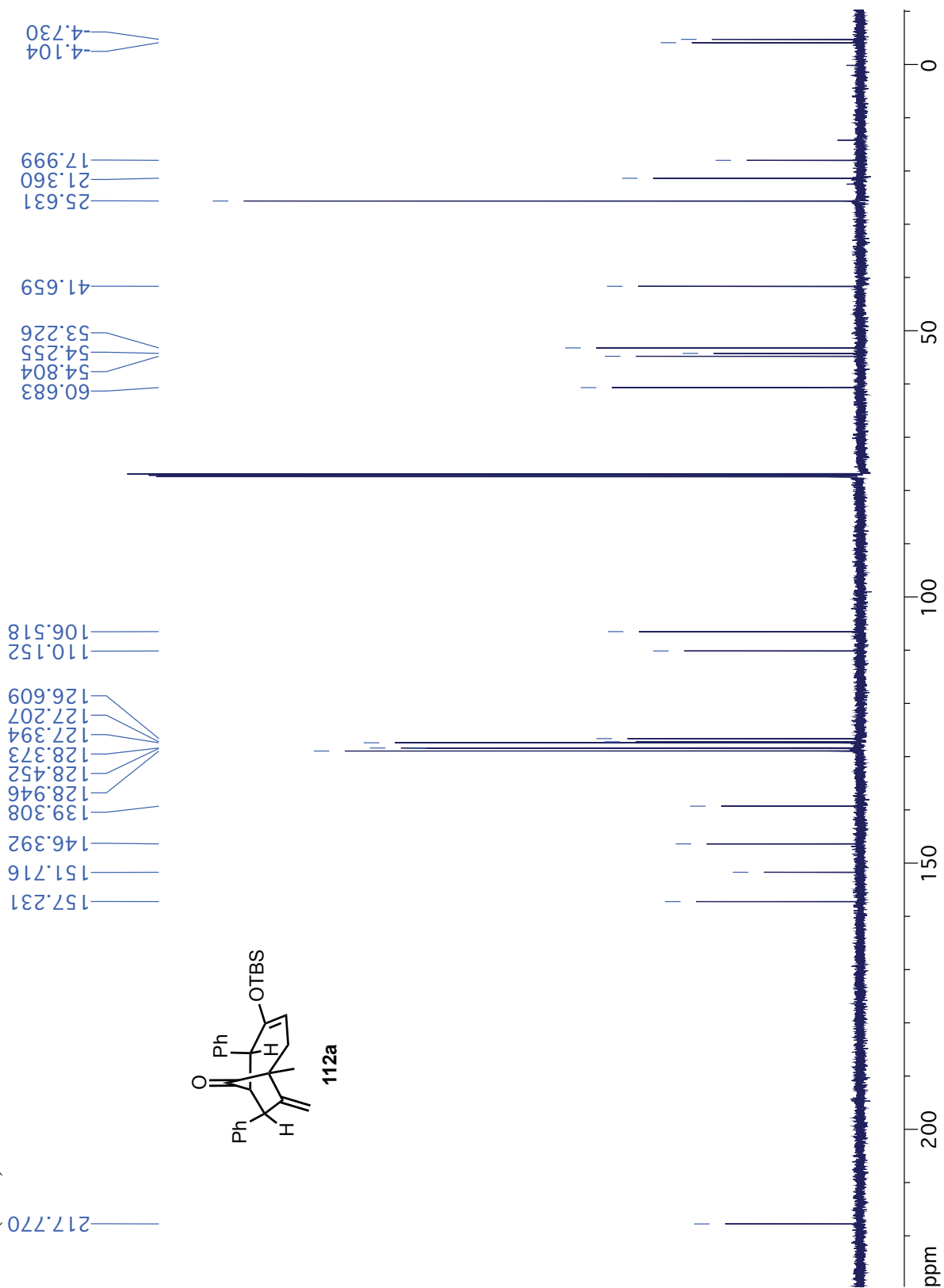

¹H NMR (CDCl₃, 500 MHz): (1*R**, 5*R**, 6*S**, 7*S**)-4-(*tert*-Butyldimethylsilyloxy)-1-methyl-8-methylene-5,7-diphenylbicyclo[4.2.1]non-3-en-9-one (112b) and (1*R**, 2*R**, 6*S**, 7*S**)-3-(*tert*-butyldimethylsilyloxy)-1-methyl-8-methylene-2,7-diphenylbicyclo[4.2.1]non-3-en-9-one (113)

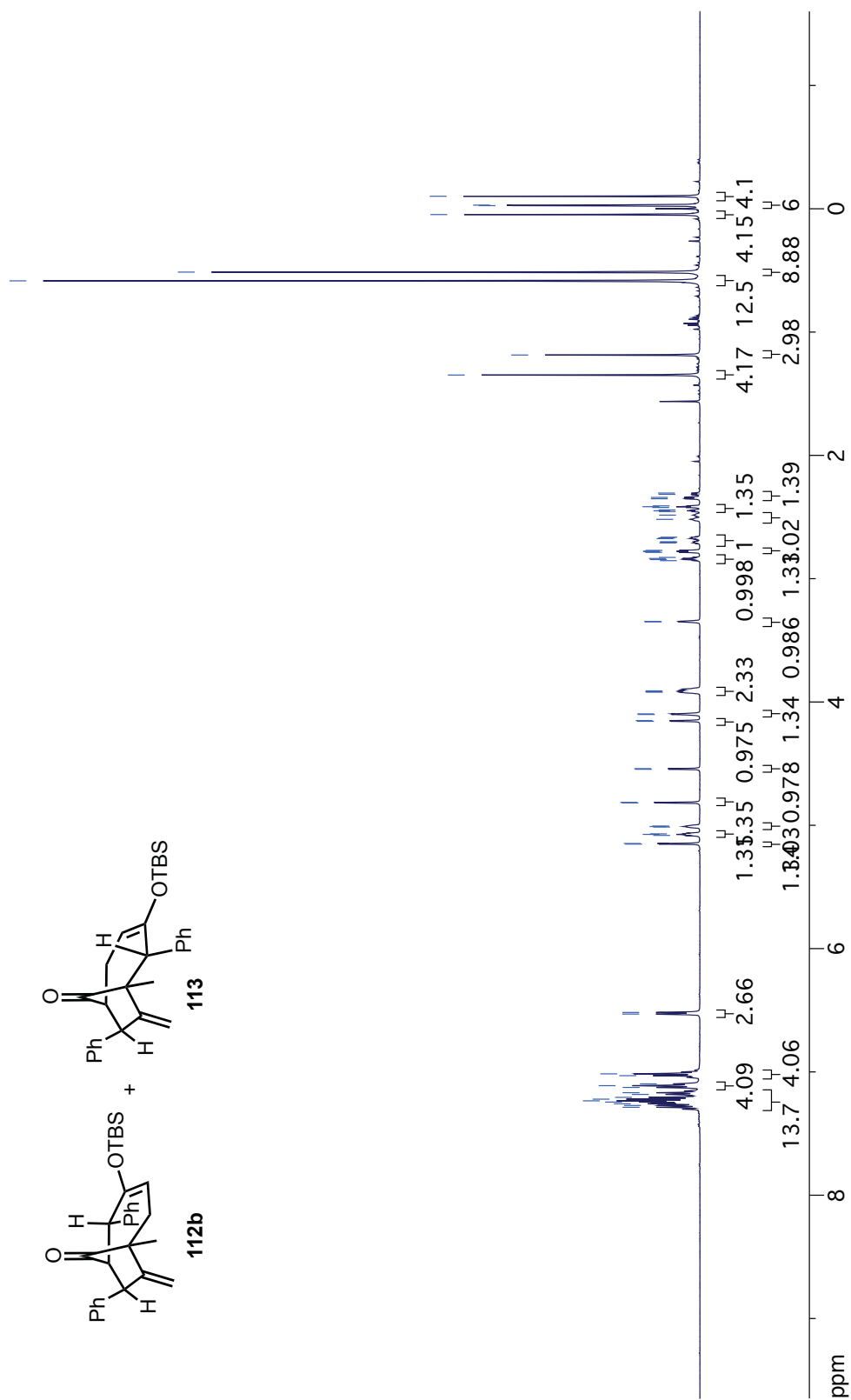
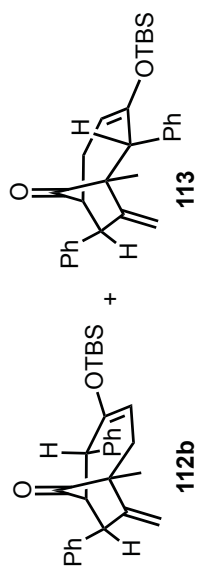
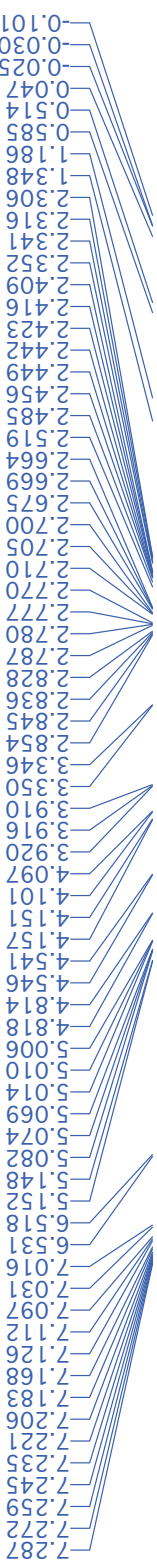

¹³C NMR (CDCl₃, 126 MHz): (1*R**,5*R**,6*S**,7*S**)-4-(*tert*-Butyldimethylsilyloxy)-1-methyl-8-methylene-5,7-diphenylbicyclo[4.2.1]non-3-en-9-one (112b) and (1*R**,2*R**,6*S**,7*S**)-3-(*tert*-butyldimethylsilyloxy)-1-methyl-8-methylene-2,7-diphenylbicyclo[4.2.1]non-3-en-9-one (113)

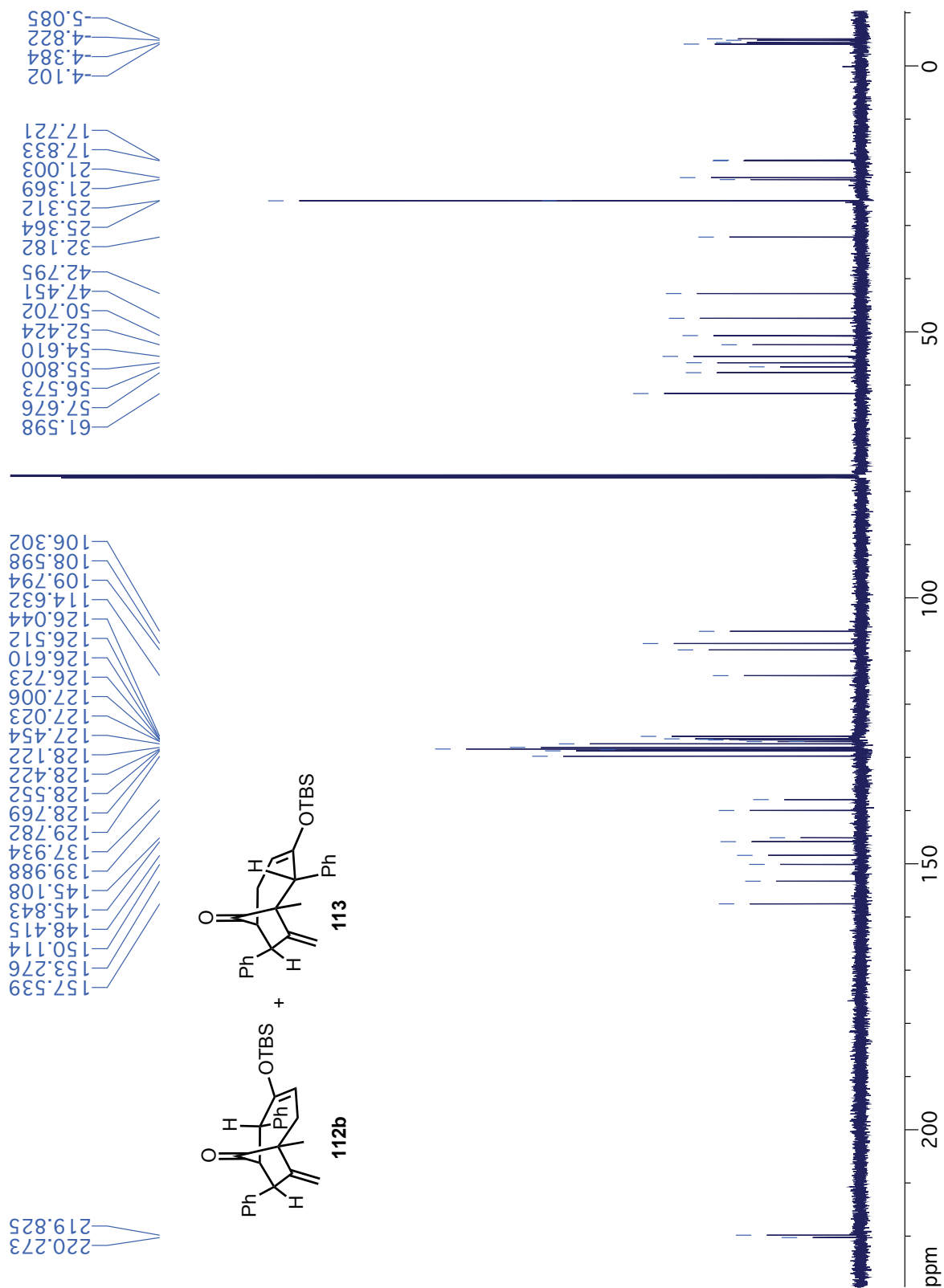

¹H NMR (CDCl₃, 500 MHz): (1*R**, 2*S**, 4*S**, 5*S**)-2-(1-Methoxy-2-methylprop-1-en-1-yl)-1-methyl-6-methylene-5-phenylbicyclo-[2.2.1]heptan-7-one (114a)

7.265
7.250
7.235
7.192
7.178
7.164
7.119
7.104

5.102
5.098
4.807

3.778
3.550

3.054
3.044
3.034
3.023

2.304
2.295
2.258
2.248
2.237
2.233
2.223
2.213

1.978
1.957
1.954
1.933
1.709
1.645
1.078

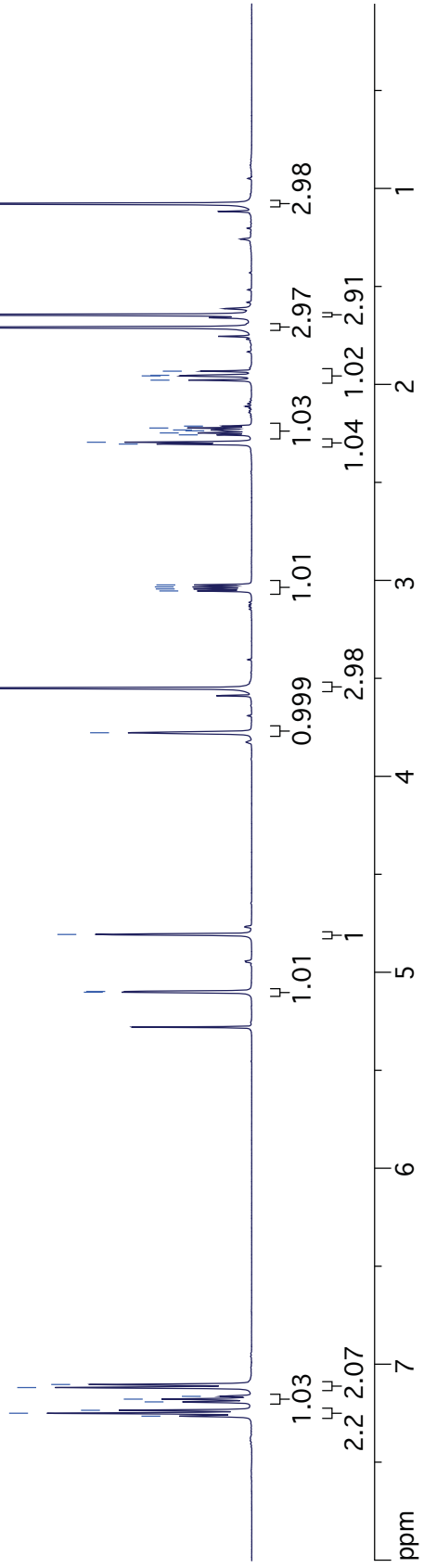
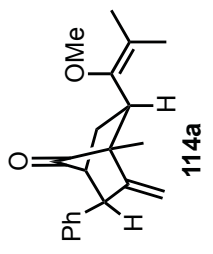

¹³C NMR (CDCl₃, 126 MHz): (1*R**,2*S**,4*S**,5*S**)-2-(1-Methoxy-2-methylprop-1-en-1-yl)-1-methyl-6-methylene-5-phenylbicyclo[2.2.1]heptan-7-one (114a)

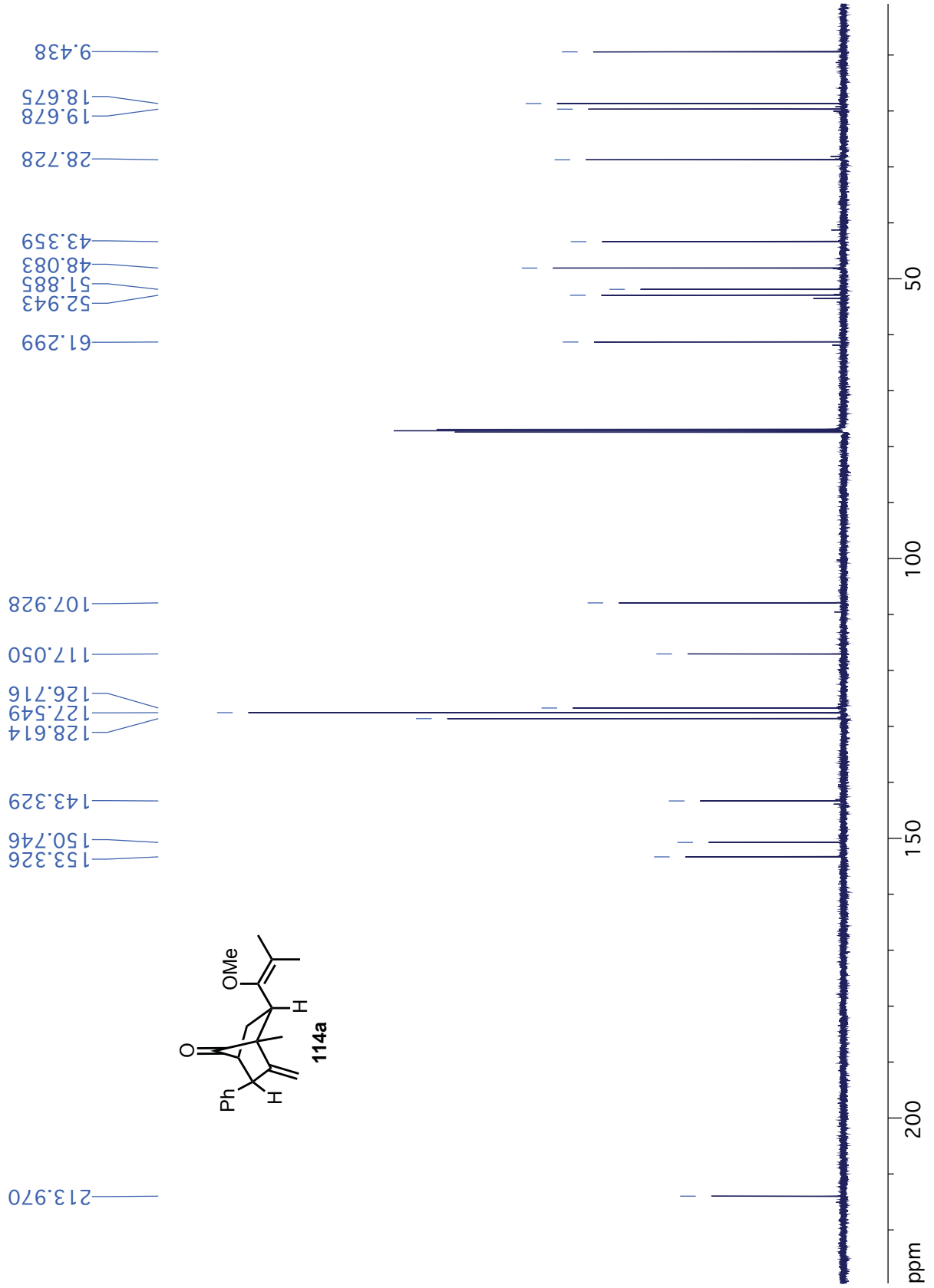
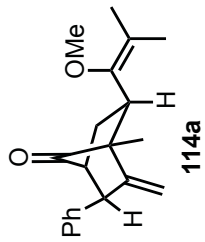

¹H NMR (CDCl₃, 500 MHz): (1*R**, 2*R**, 4*S**, 5*S**)-2-(1-Methoxy-2-methylprop-1-en-1-yl)-1-methyl-6-methylene-5-phenylbicyclo-[2.2.1]heptan-7-one (114b)

7.269
7.257
7.240
7.197
7.183
7.168
7.119
7.104

4.949
4.944
4.772
4.767

3.825
3.591

3.148
3.135
3.127
3.114

2.308
2.299
2.172
2.162
2.147
2.138
2.125
2.113
2.100
2.088
2.075
1.757
1.662

1.118

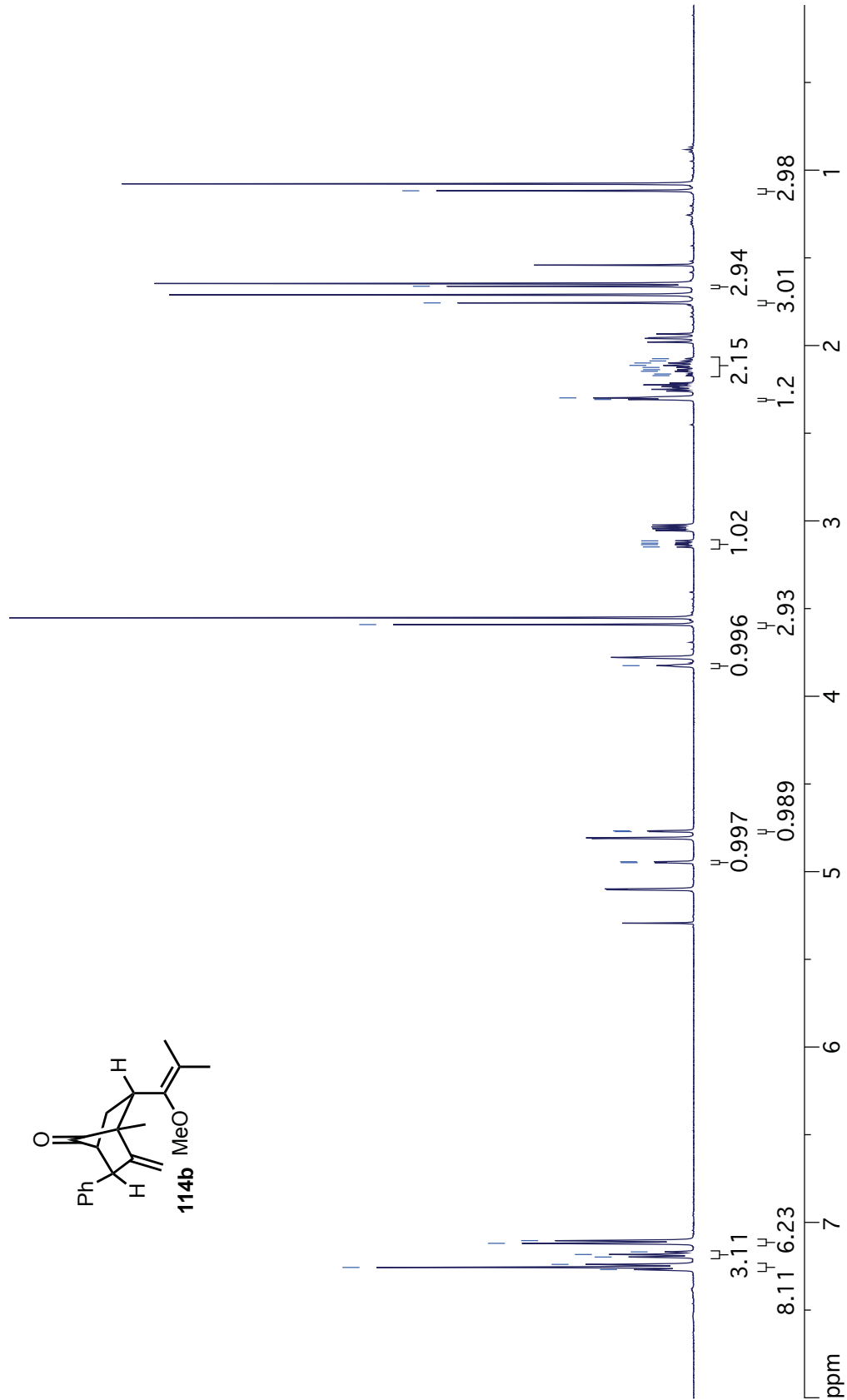
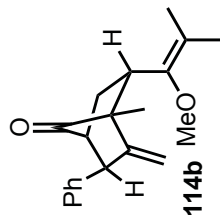

¹³C NMR (CDCl₃, 126 MHz): (1*R**,2*R**,4*S**,5*S**)-2-(1-Methoxy-2-methylprop-1-en-1-yl)-1-methyl-6-methylene-5-phenylbicyclo-[2.2.1]heptan-7-one (114b)

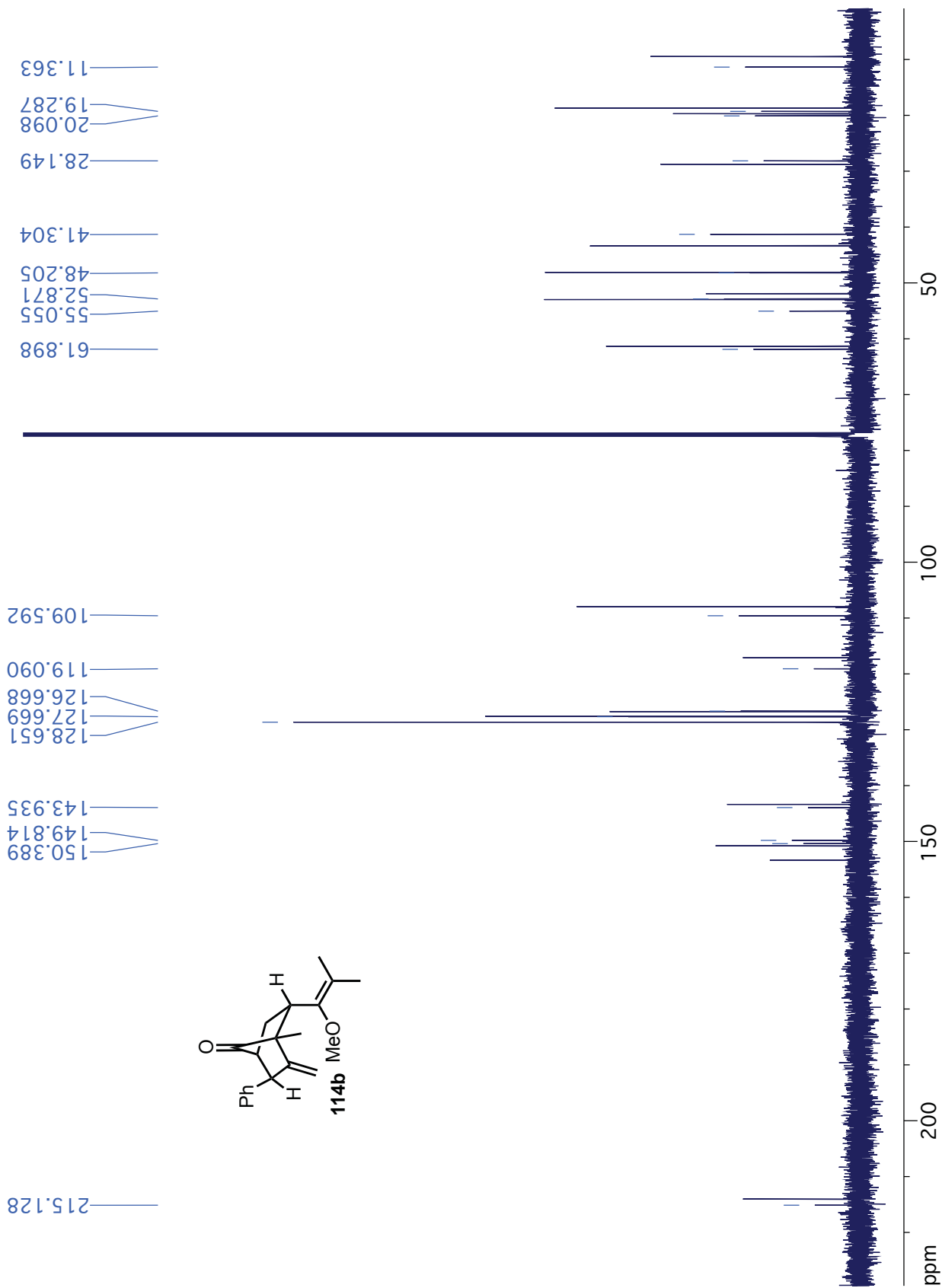
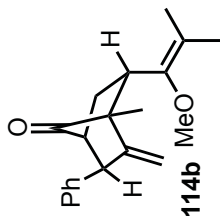

¹H NMR (CDCl₃, 500 MHz): (1R*,6S*,7S*)-4-(*tert*-Butyldimethylsilyloxy)-1,3-dimethyl-8-methylene-7-phenylbicyclo[4.2.1]non-3-en-9-one (115)

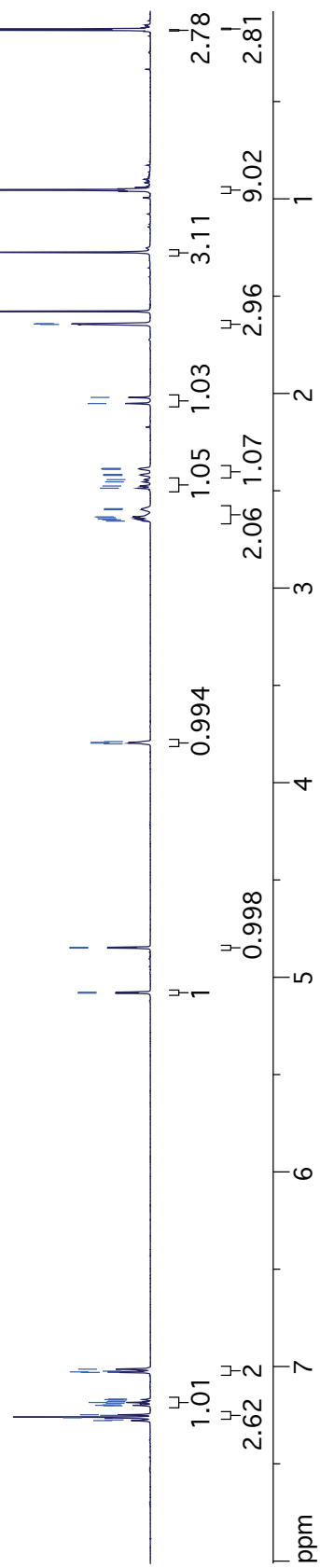
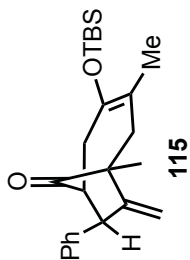
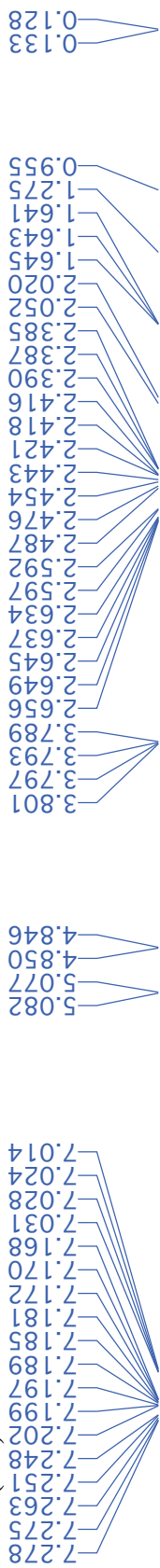

¹³C NMR (CDCl₃, 126 MHz): (1*R**,6*S**,7*S**)-4-(*tert*-Butyldimethylsilyloxy)-1,3-dimethyl-8-methylene-7-phenylbicyclo[4.2.1]non-3-en-9-one (115)

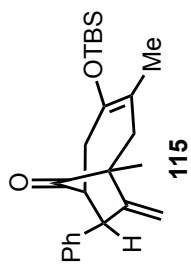
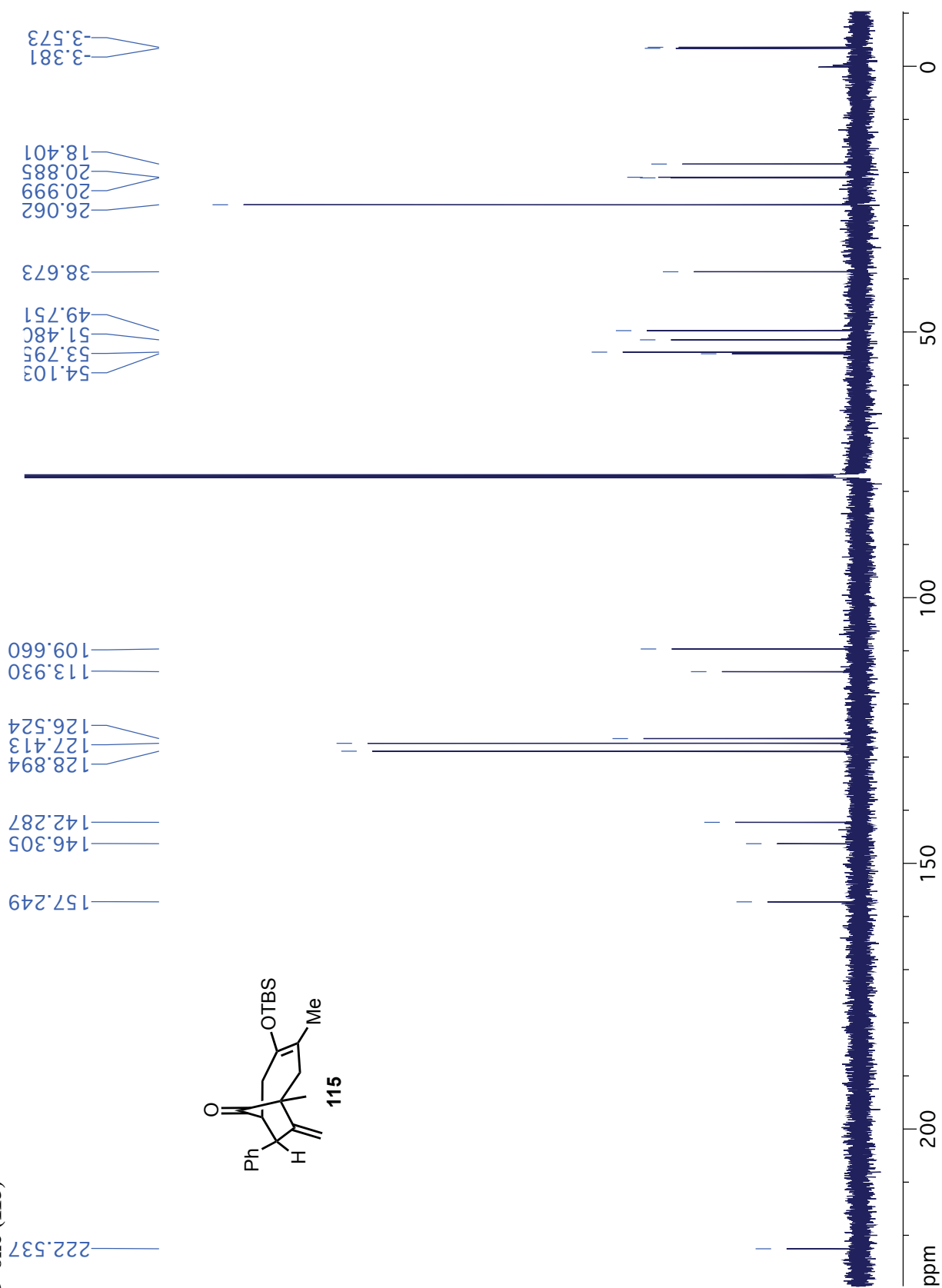

¹H NMR (CDCl₃, 500 MHz): (1*R**,2*R**,6*S**,7*S**)-4-(*tert*-Butyldimethylsilyloxy)-1,2-dimethyl-8-methylene-7-phenylbicyclo[4.2.1]non-3-en-9-one (**116**)

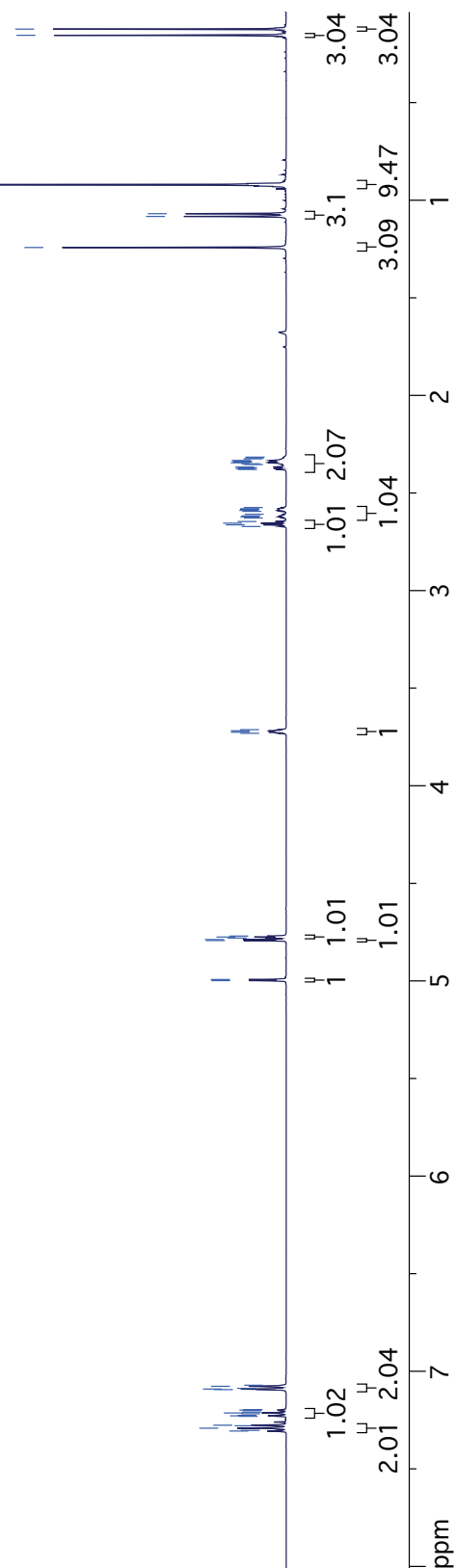
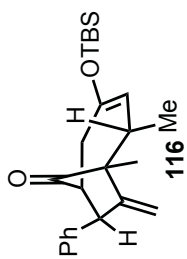
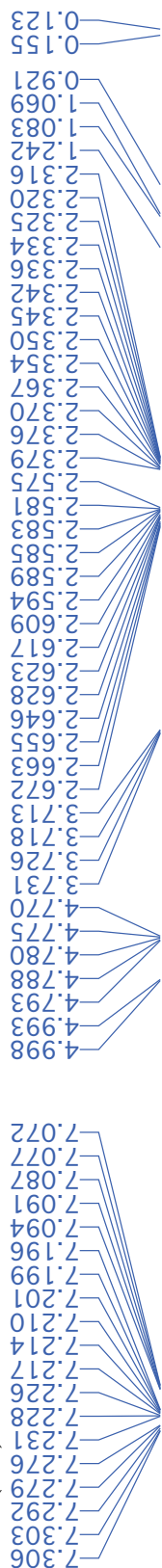

¹³C NMR (CDCl₃, 126 MHz): (1*R**,2*R**,6*S**,7*S**)-4-(*tert*-Butyldimethylsilyloxy)-1,2-dimethyl-8-methylene-7-phenylbicyclo[4.2.1]non-3-en-9-one (116)

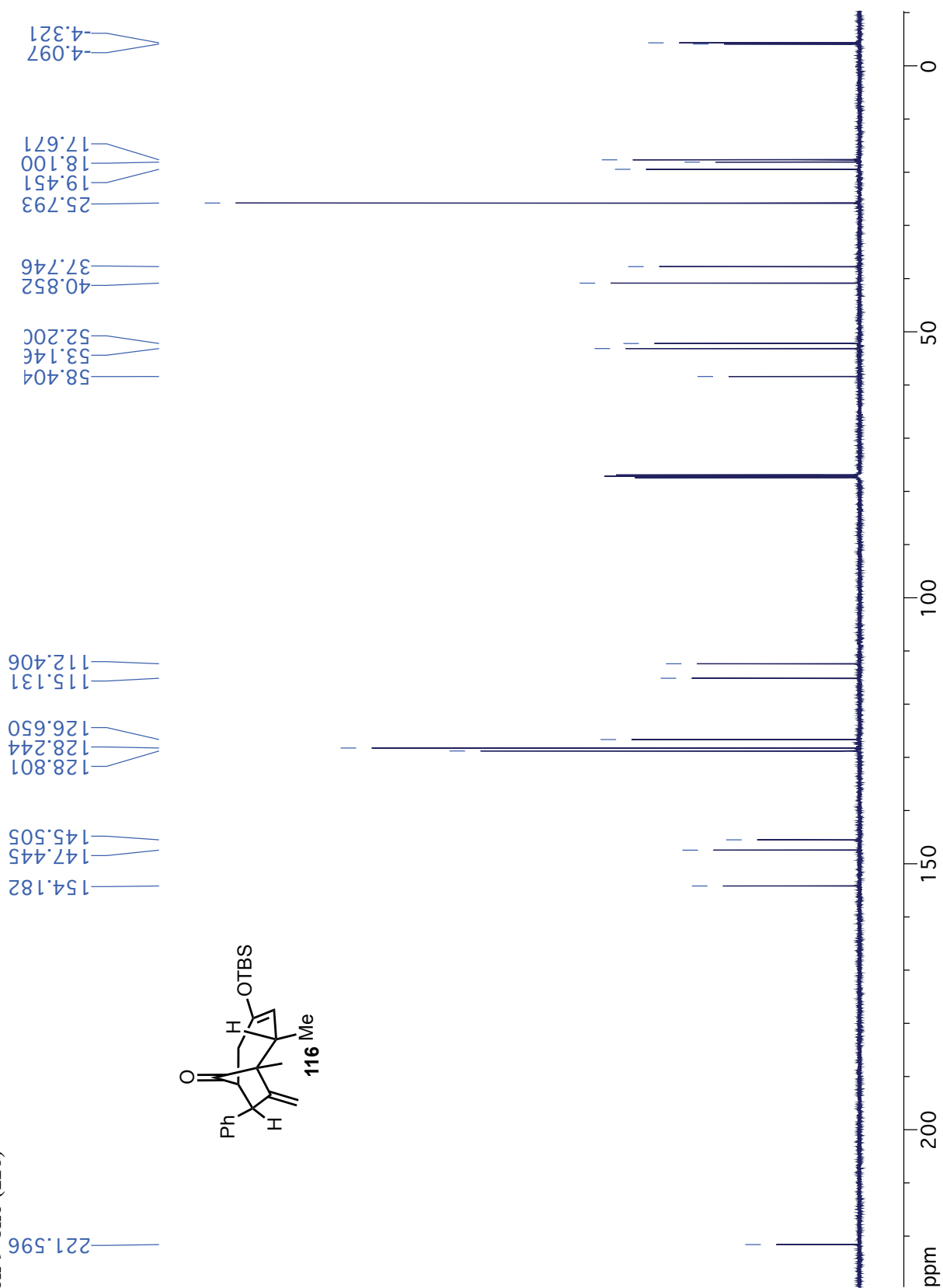

¹H NMR (CDCl₃, 500 MHz): (1R*,6S*,7S*)-4-(*tert*-Butyldimethylsilyloxy)-1,2,2-trimethyl-8-methylene-7-phenylbicyclo[4.2.1]non-3-en-9-one (117)

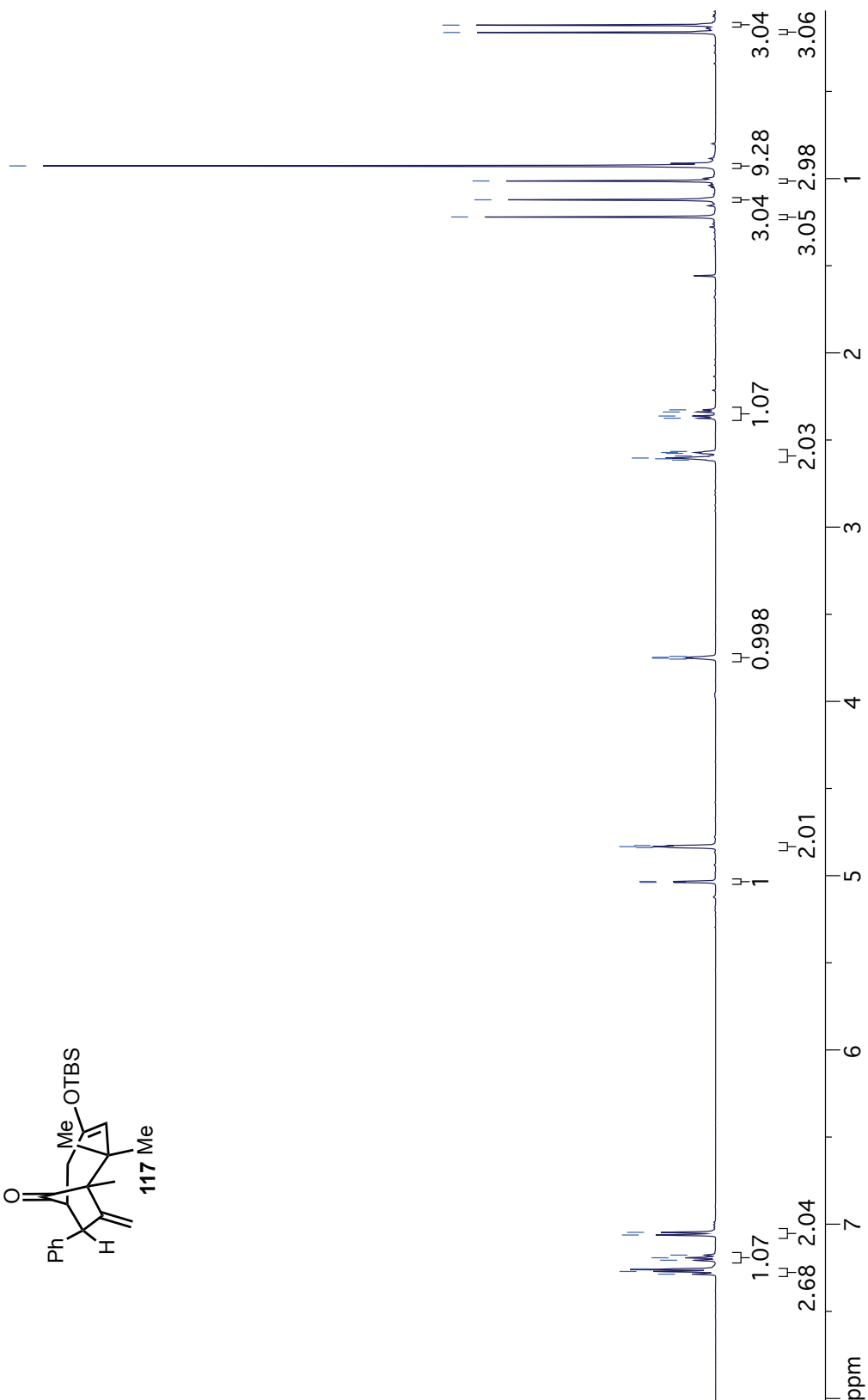
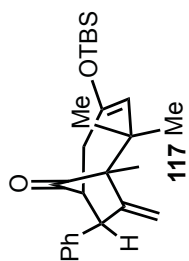
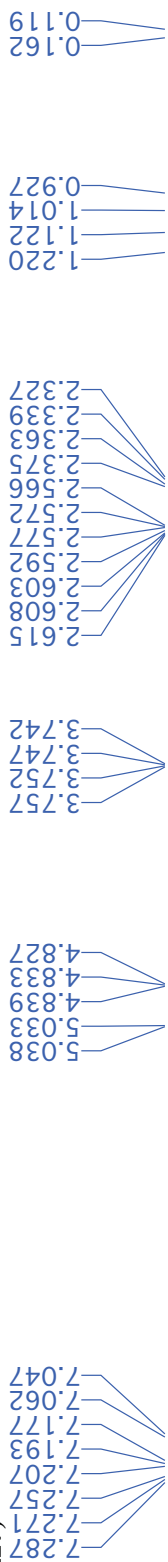

¹³C NMR (CDCl₃, 126 MHz): (1R*,6S*,7S*)-4-(*tert*-Butyldimethylsilyloxy)-1,2,2-trimethyl-8-methylene-7-phenylbicyclo[4.2.1]non-3-en-9-one (117)

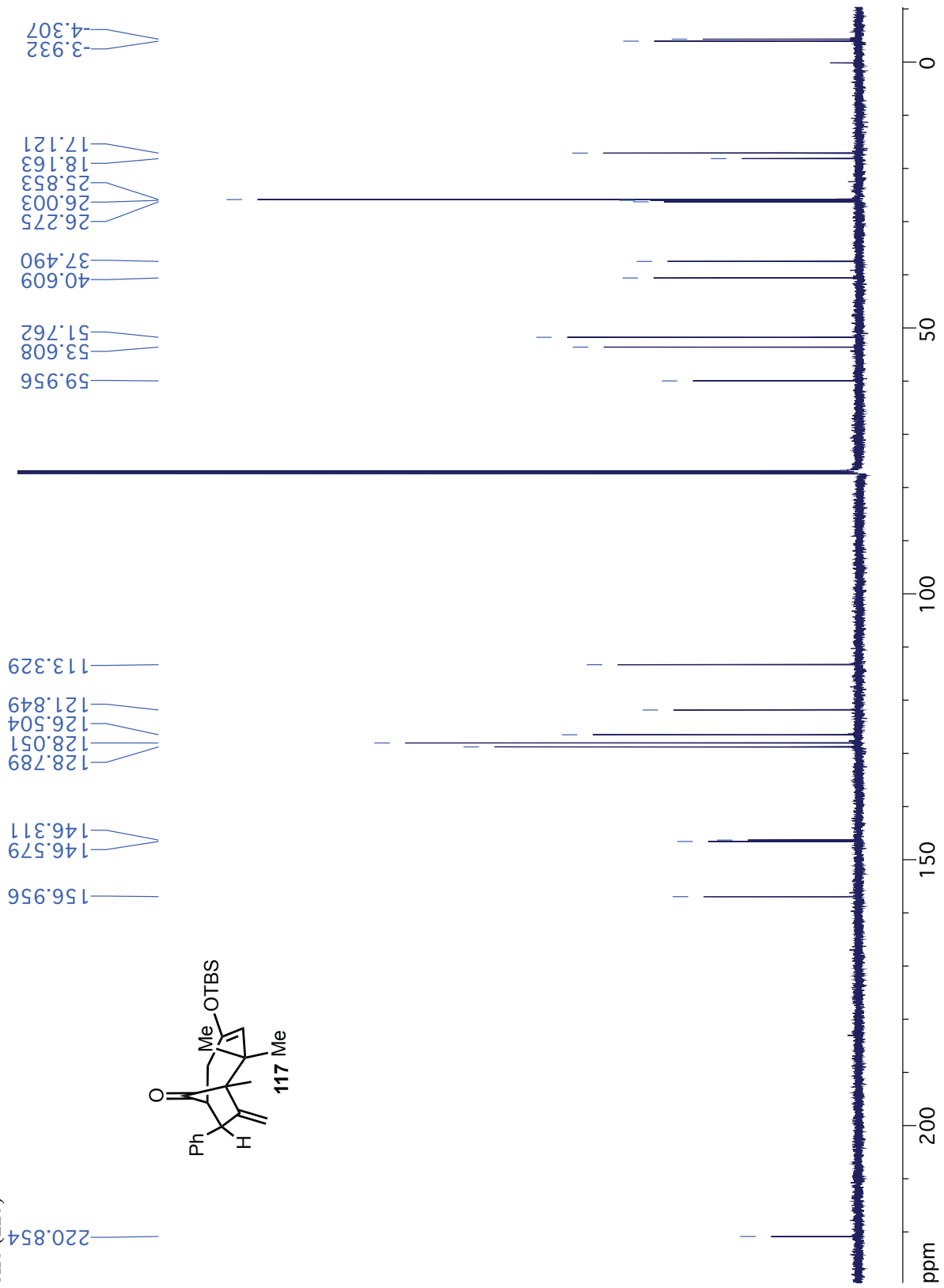
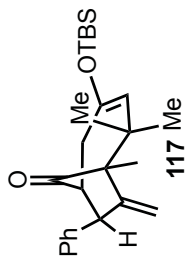

¹H NMR (CDCl₃, 500 MHz): (1*R**,2*R**,10*S**,11*S**,11*S**)-8-(*tert*-Butyldimethylsilyloxy)-1-methyl-12-methylene-11-phenyltricyclo[8².7.2.1]-tridec-7-en-13-one (118)

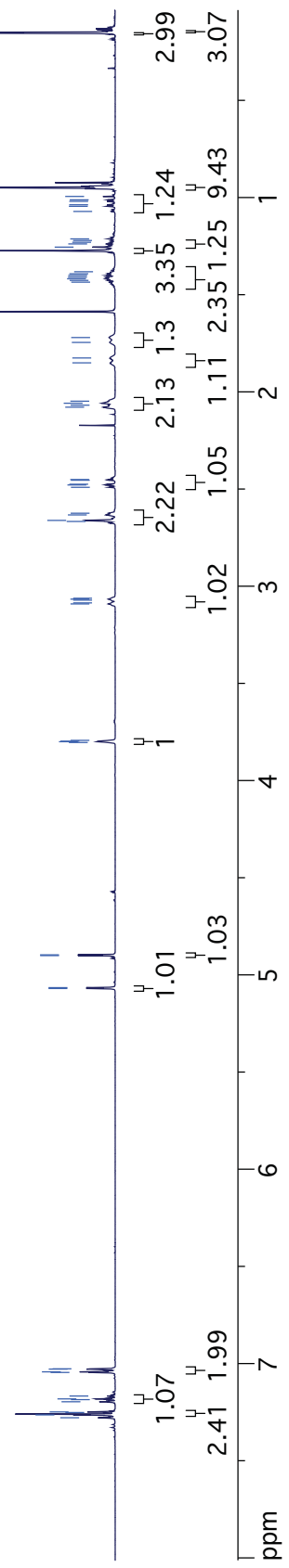
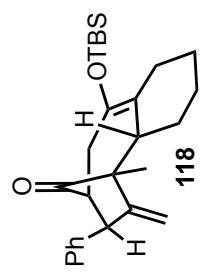
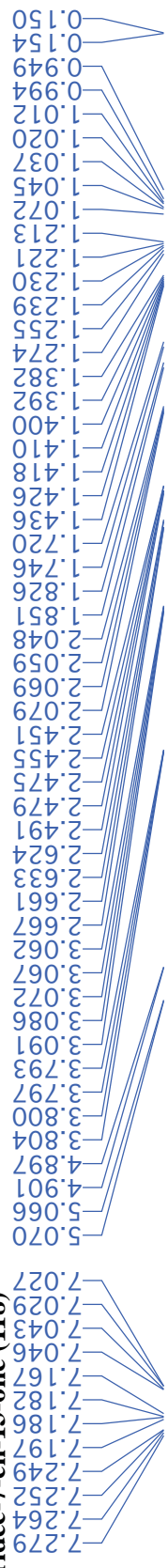

¹³C NMR (CDCl₃, 126 MHz): (1*R**, 2*R**, 10*S**, 11*S**)-8-(*tert*-Butyldimethylsilyloxy)-1-methyl-12-methylene-11-phenyltricyclo[8².7.2.1]-tridec-7-en-13-one (118)

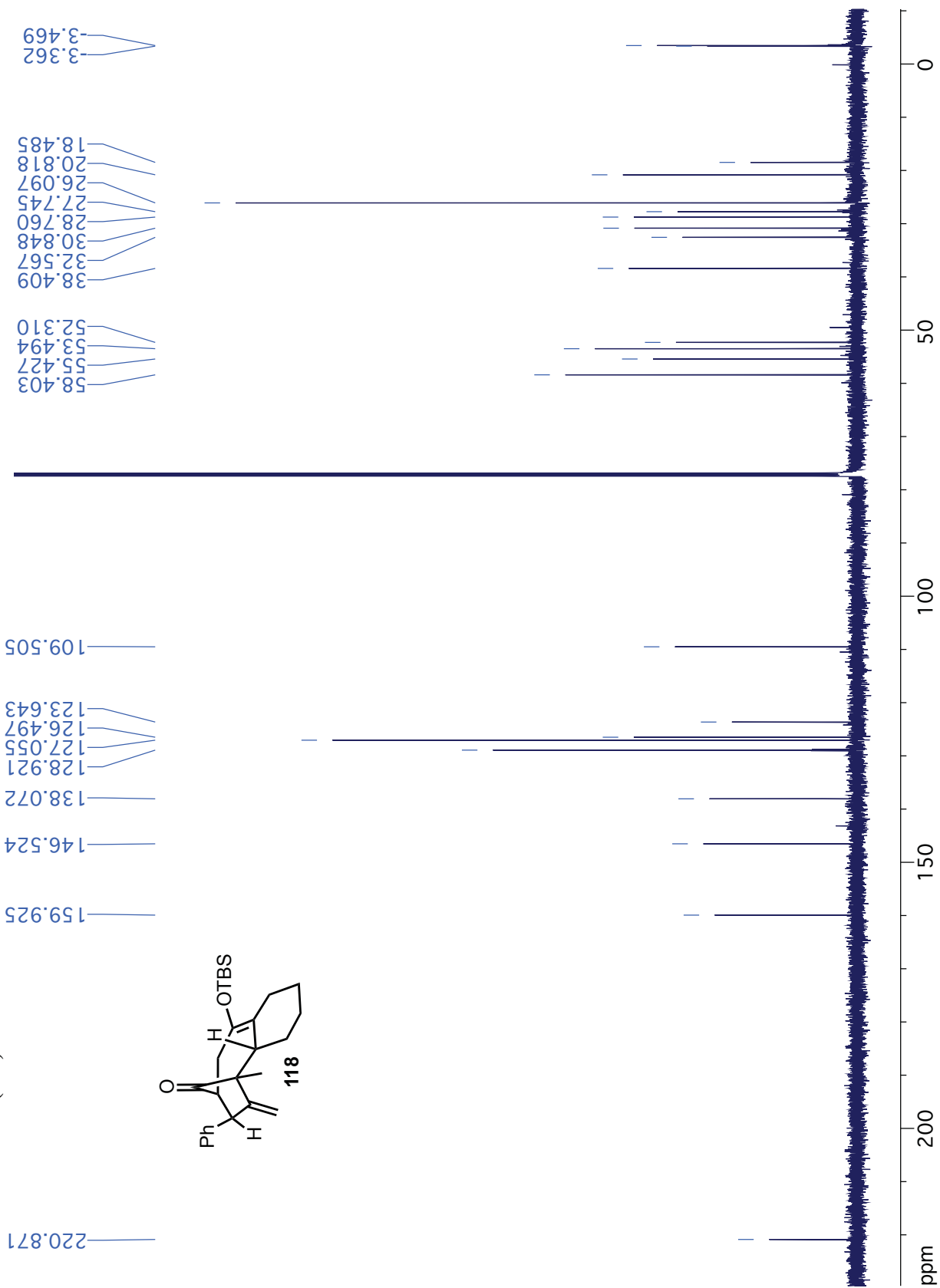

¹H NMR (CDCl₃, 500 MHz): (1*R**, 2*S**, 5*S**, 6*S**, 7*S**)-4-(*tert*-Butyldimethylsilyloxy)-1,2,5-trimethyl-8-methylene-7-phenylbicyclo[4.2.1]non-3-en-9-one (120)

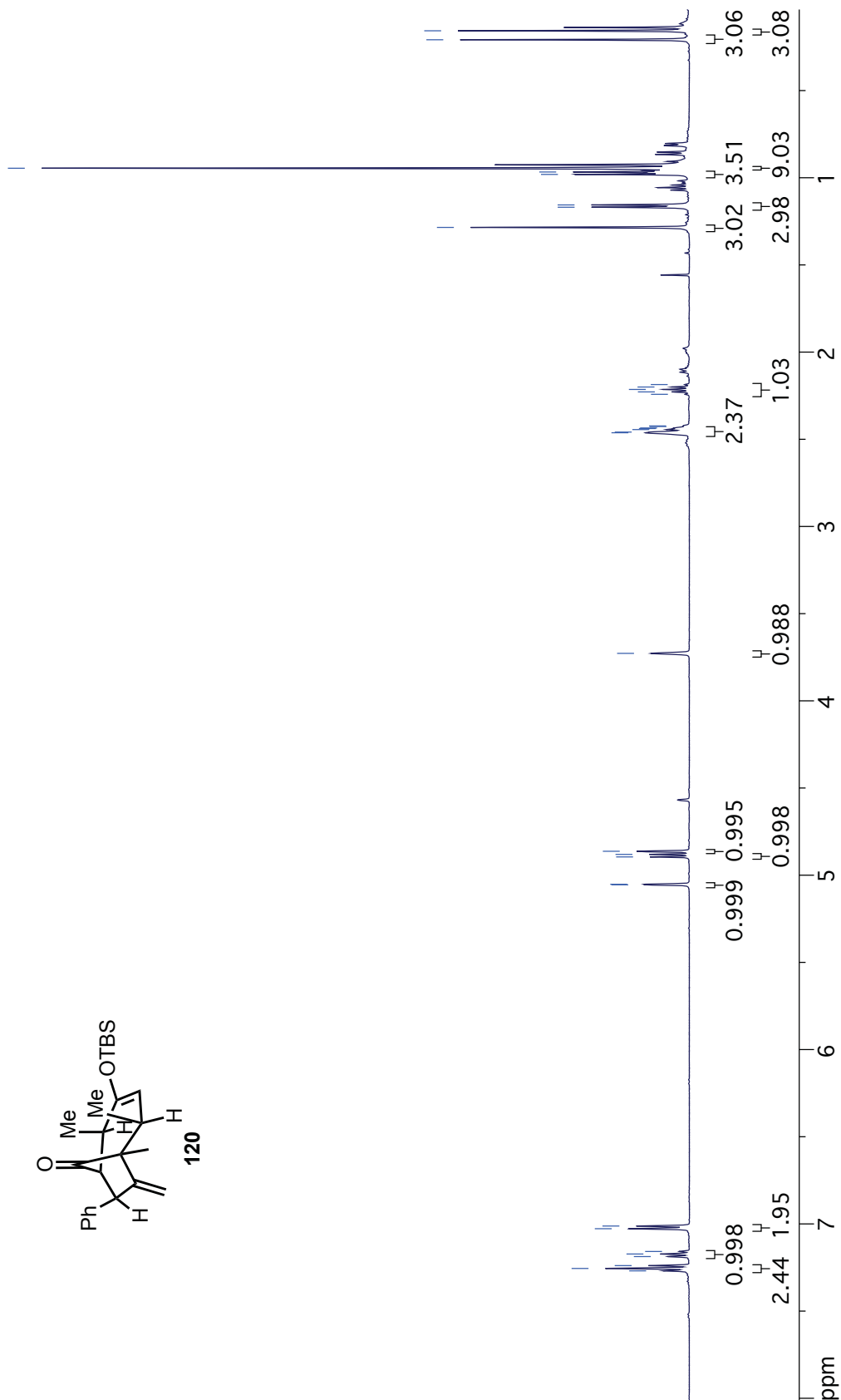
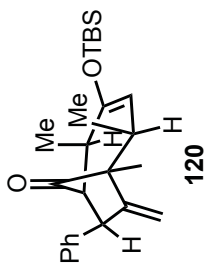
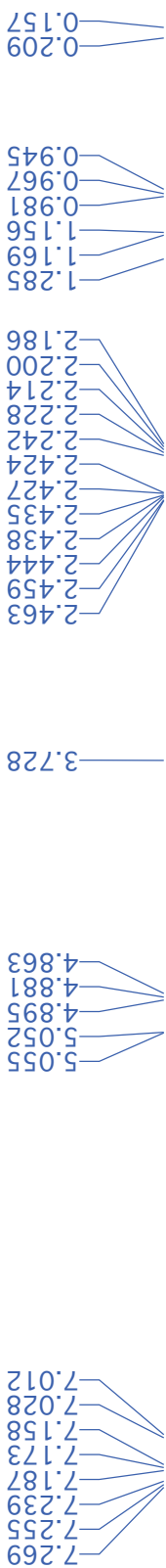

¹³C NMR (CDCl₃, 126 MHz): (1R*,2S*,5S*,6S*,7S*)-4-(*tert*-Butyldimethylsilyloxy)-1,2,5-trimethyl-8-methylene-7-phenylbicyclo-[4.2.1]non-3-en-9-one (120)

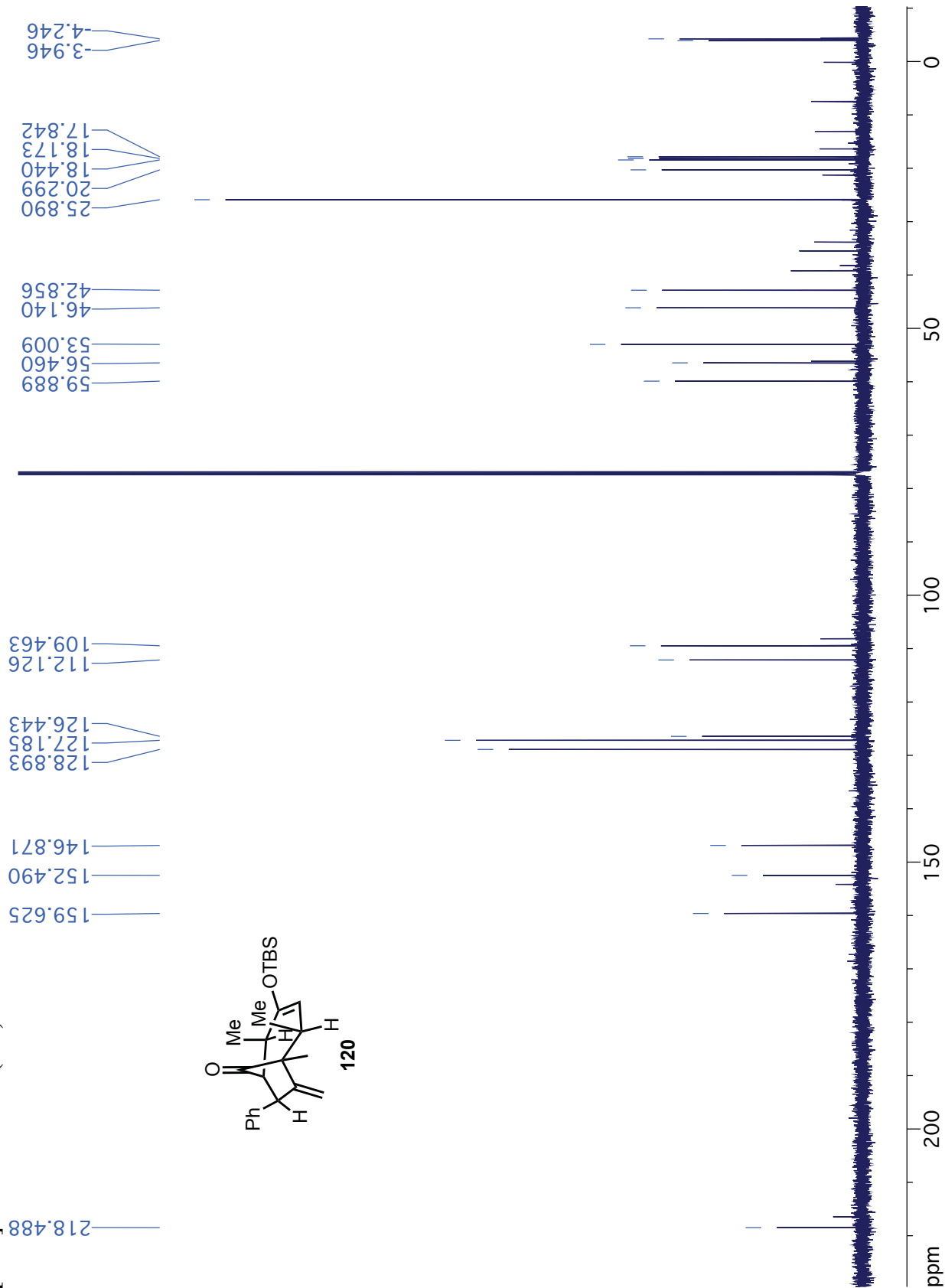

¹H NMR (CDCl₃, 500 MHz): (1*R**, 2*R**, 5*R**, 6*S**, 7*S**)-4-(*tert*-Butyldimethylsilyloxy)-1,2,5-trimethyl-8-methylene-7-phenylbicyclo-[4.2.1]non-3-en-9-one (121)

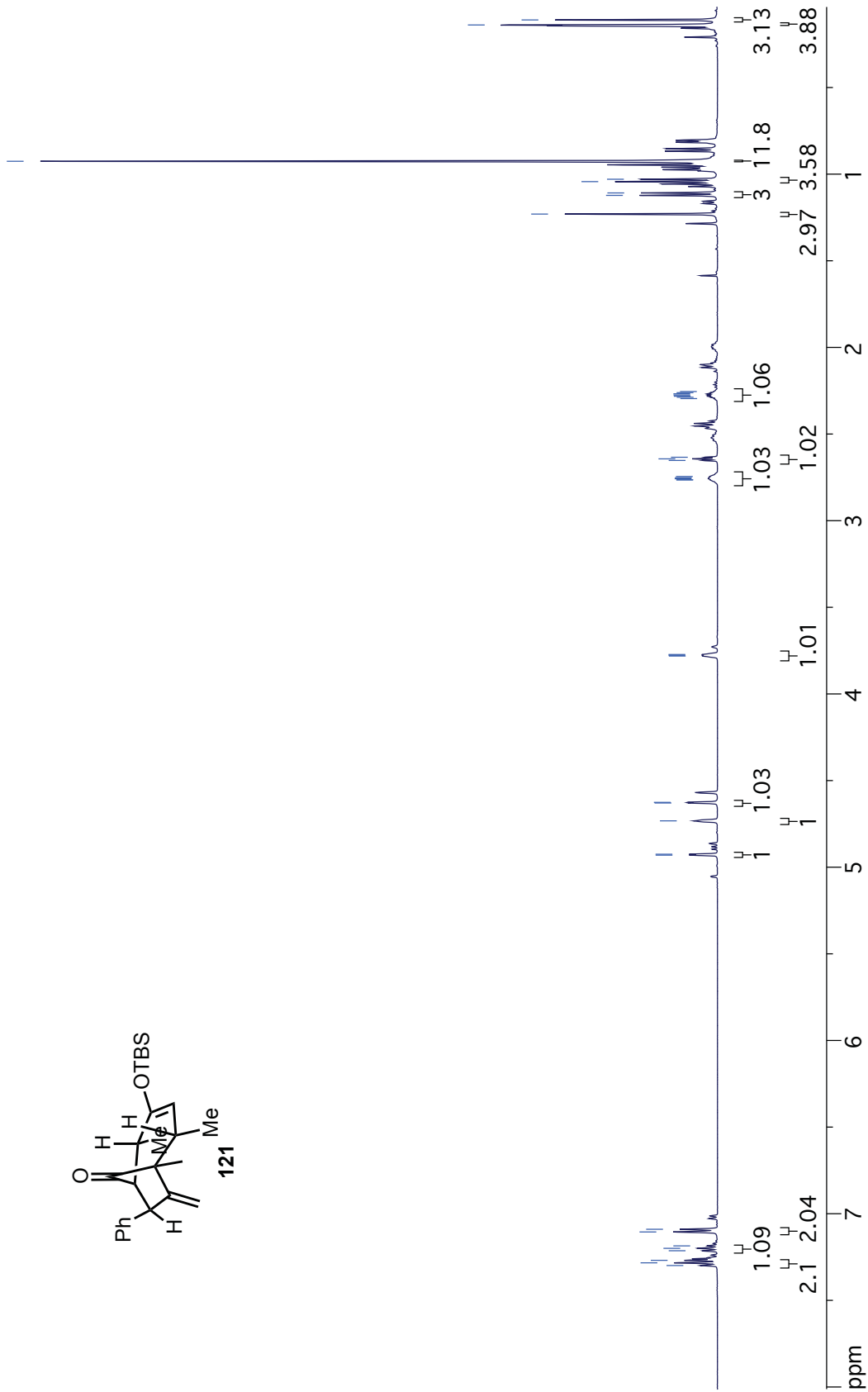
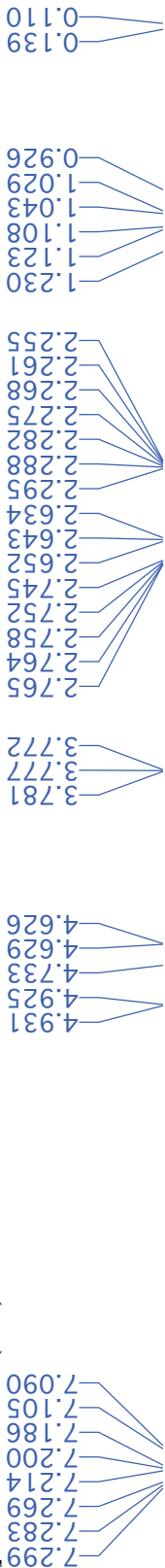

¹³C NMR (CDCl₃, 126 MHz): (1*R**, 2*R**, 5*R**, 6*S**, 7*S**)-4-(*tert*-Butyldimethylsilyloxy)-1,2,5-trimethyl-8-methylene-7-phenylbicyclo-[4.2.1]non-3-en-9-one (121)

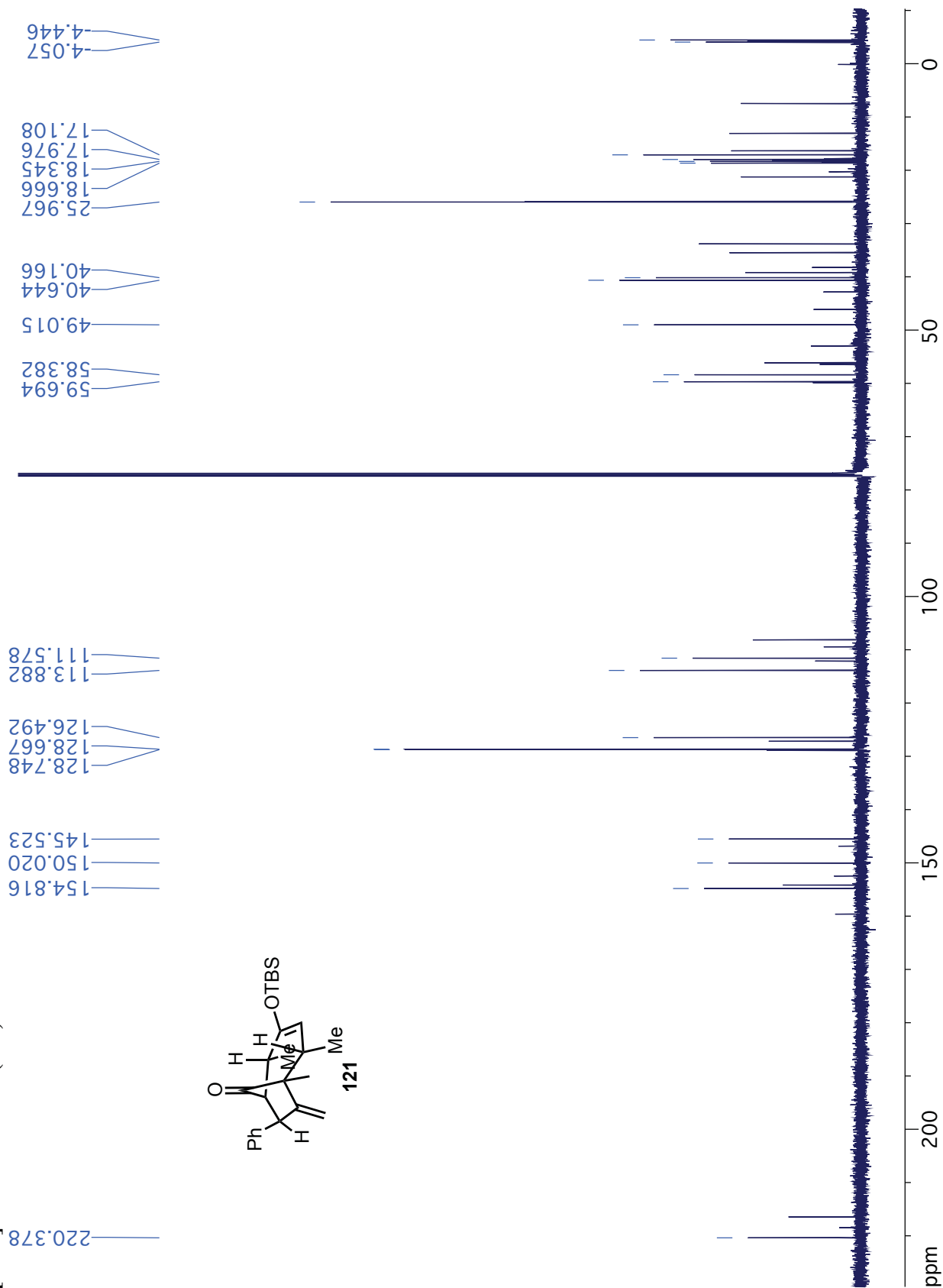
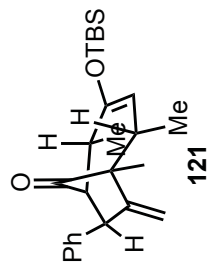

¹H NMR (CDCl₃, 500 MHz): (1*R**,5*R**,6*S**,8*R**)-4-(*tert*-Butyldimethylsilyloxy)-1,5-dimethyl-7-methylene-8-phenylbicyclo[4.2.1]non-3-en-9-one (122a), and (1*R**,5*S**,6*S**,8*R**)-4-(*tert*-butyldimethylsilyloxy)-1,5-dimethyl-7-methylene-8-phenylbicyclo[4.2.1]non-3-en-9-one (122b)

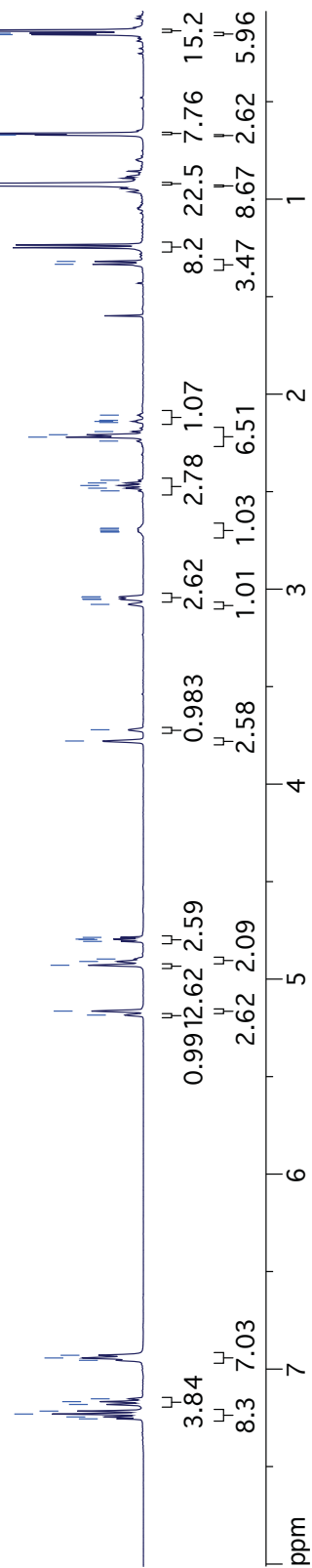
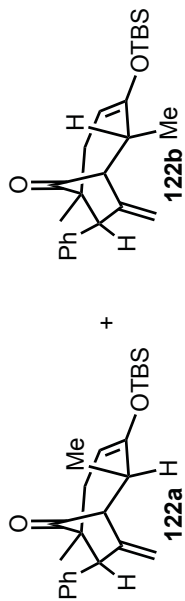
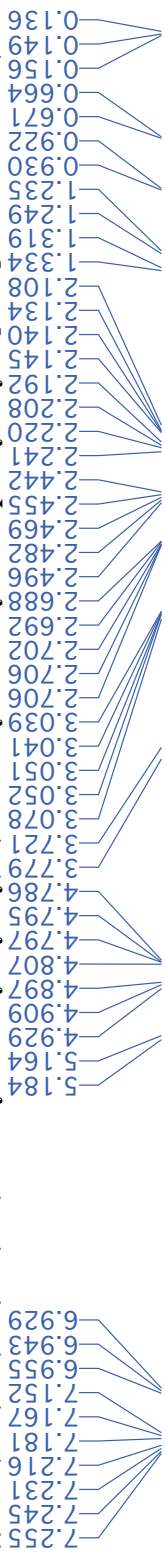

¹³C NMR (CDCl₃, 126 MHz): (1*R**,5*R**,6*S**,8*R**)-4-(*tert*-Butyldimethylsilyloxy)-1,5-dimethyl-7-methylene-8-phenylbicyclo[4.2.1]non-3-en-9-one (122a), and (1*R**,5*S**,6*S**,8*R**)-4-(*tert*-butyldimethylsilyloxy)-1,5-dimethyl-7-methylene-8-phenylbicyclo[4.2.1]non-3-en-9-one (122b)

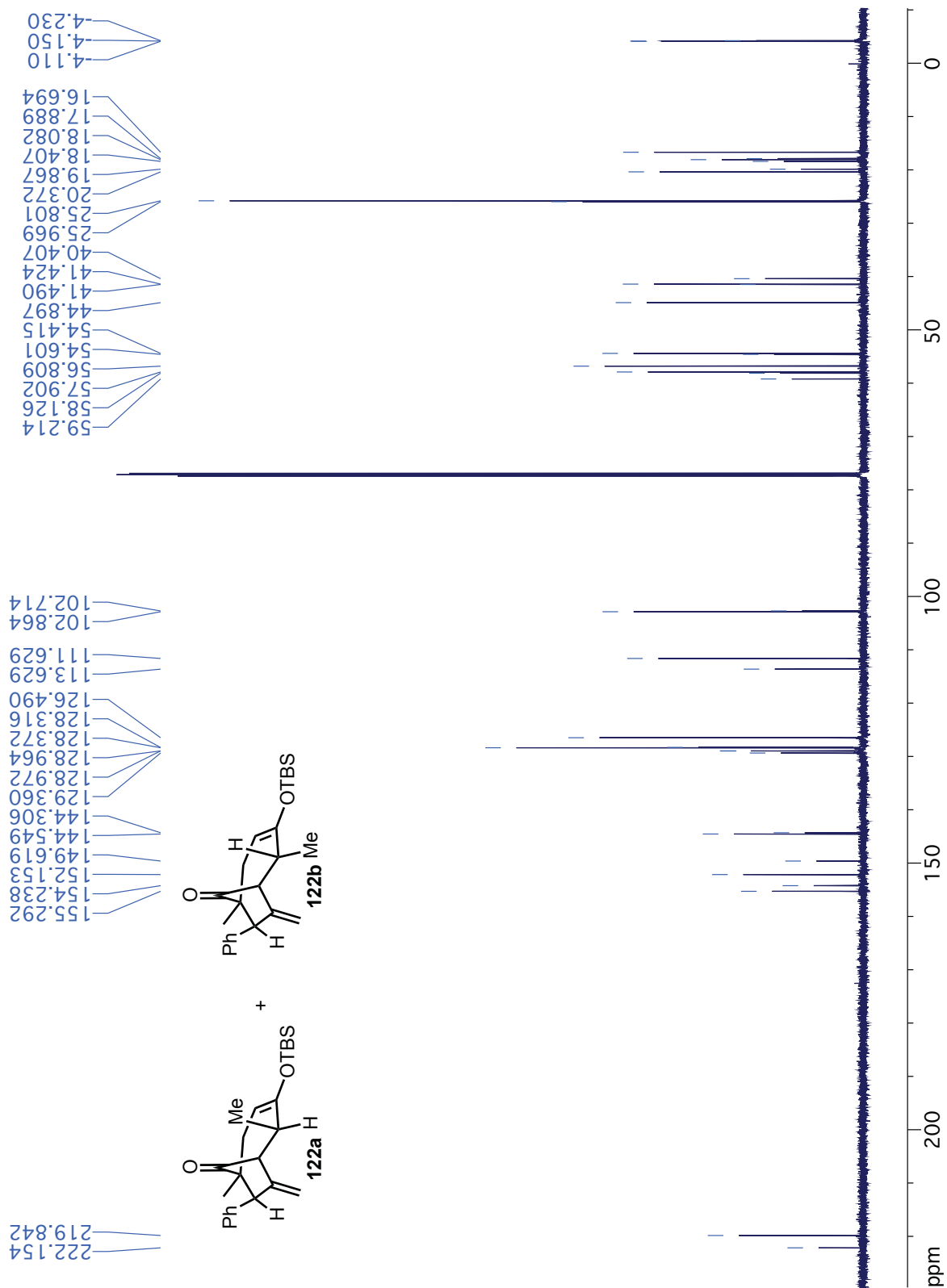

¹H NMR (CDCl₃, 500 MHz): (1*R**,6*S**,8*R**)-4-(*tert*-Butyldimethylsilyloxy)-1,5,5-trimethyl-7-methylene-8-phenylbicyclo[4.2.1]non-3-en-9-one (123)

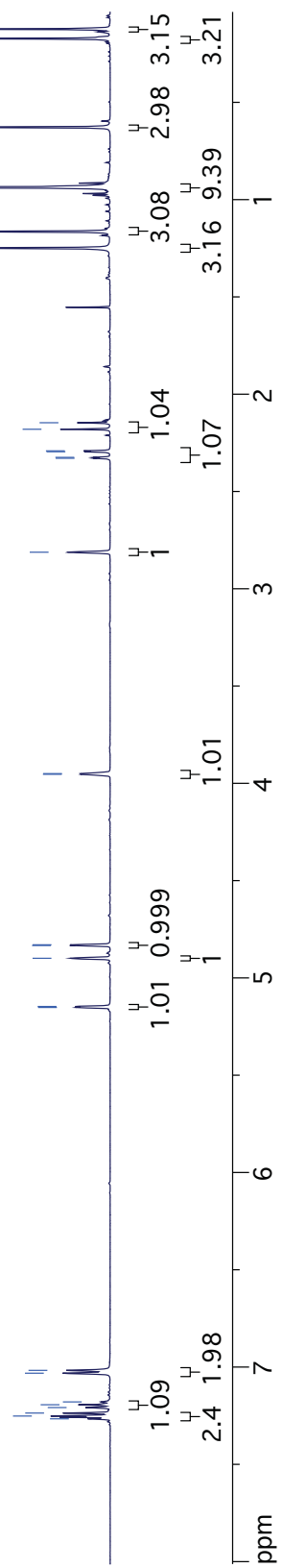
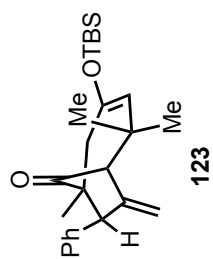

¹³C NMR (CDCl₃, 126 MHz): (1*R**,6*S**,8*R**)-4-(*tert*-Butyldimethylsilyloxy)-1,5,5-trimethyl-7-methylene-8-phenylbicyclo[4.2.1]non-3-en-9-one (123)

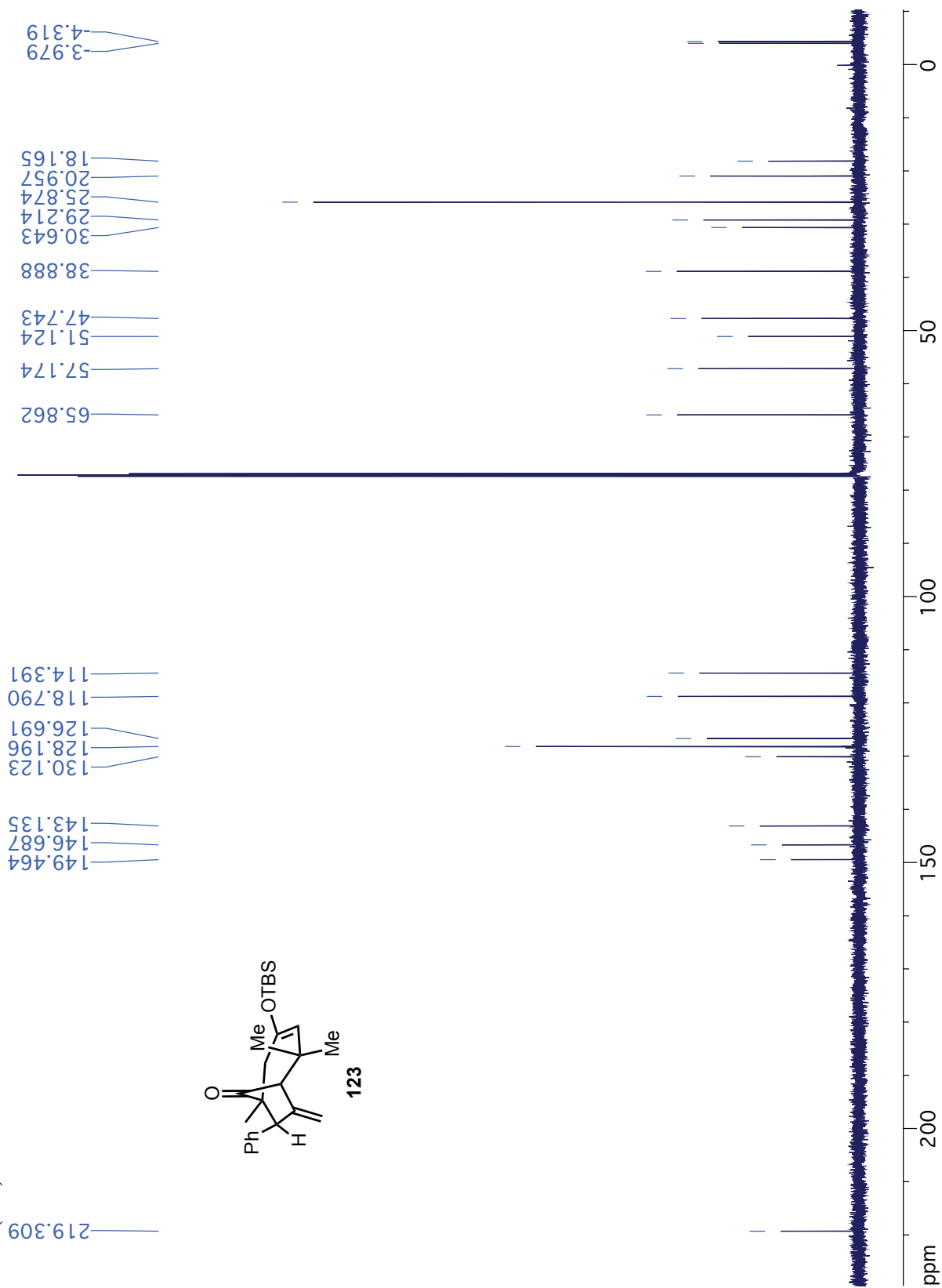

¹H NMR (CDCl₃, 500 MHz): (4aR*,8R*,9R*)-8-Methyl-10-methylenecyclohexane-1H-4a,9-methanobenzo[8]annulene-7,11(2H)-dione (124)

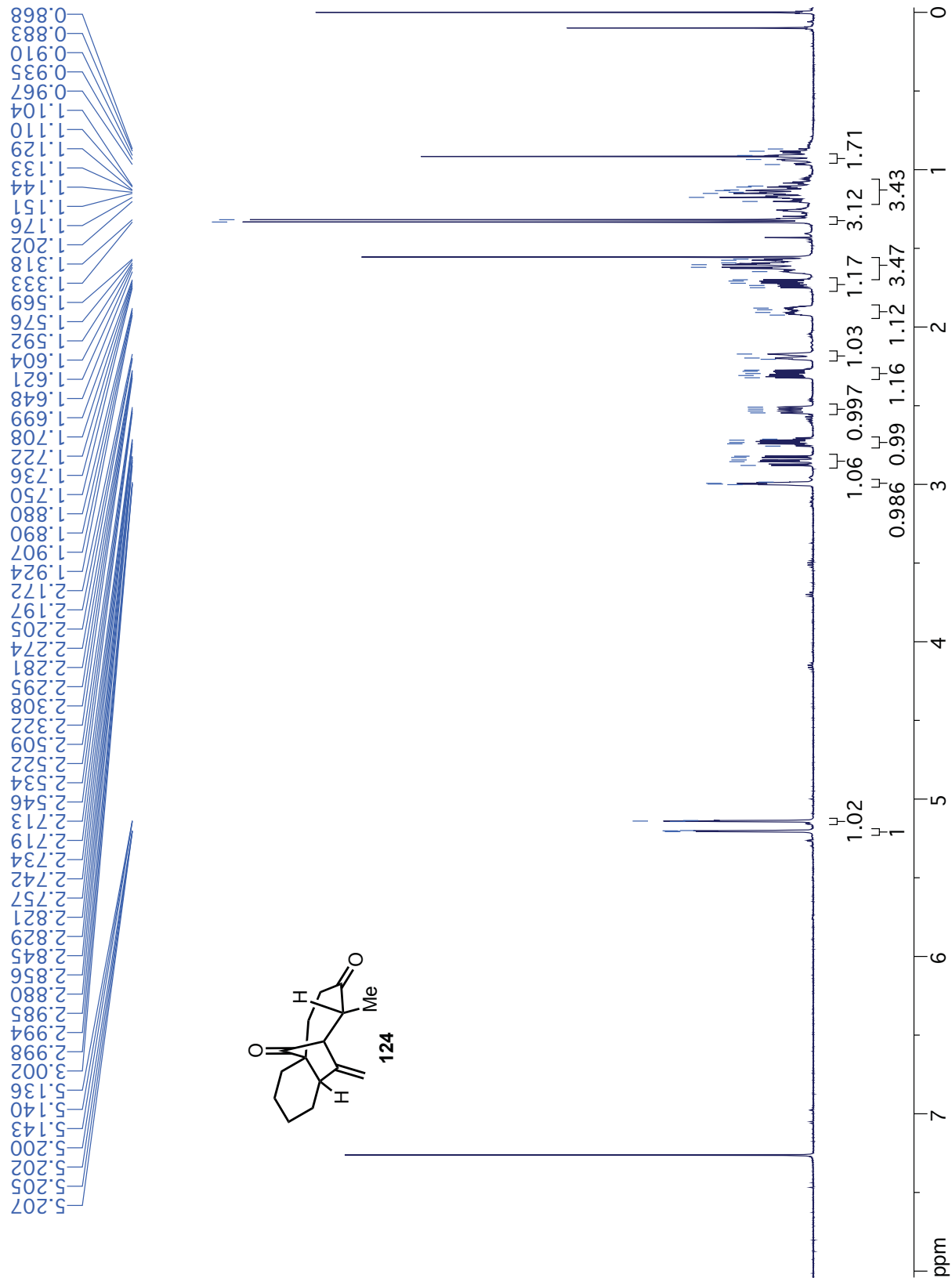

¹³C NMR (CDCl₃, 126 MHz): (4*aR**,8*R**,9*R**)-8-Methyl-10-methyleneoctahydro-1*H*-4*a*,9-methanobenzo[8]annulene-7,11(2*H*)-dione (124)

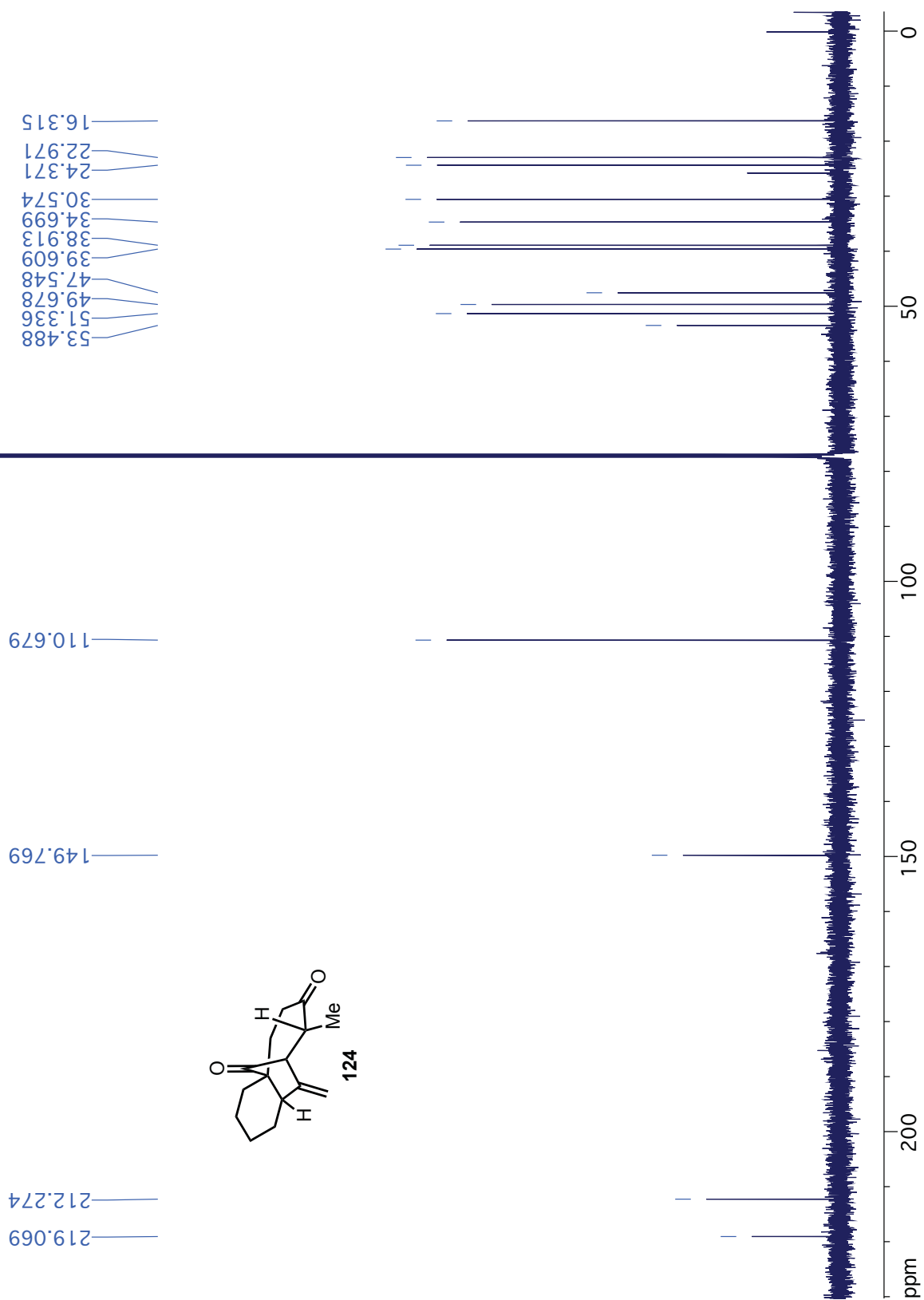

¹³C NMR (CDCl₃, 126 MHz): (1*R**,5*R**,6*S**,7*S**)-1-Methyl-8-methylene-7-phenyl-5-*iso*-propylbicyclo[4.2.1]nonane-4,9-dione (125)

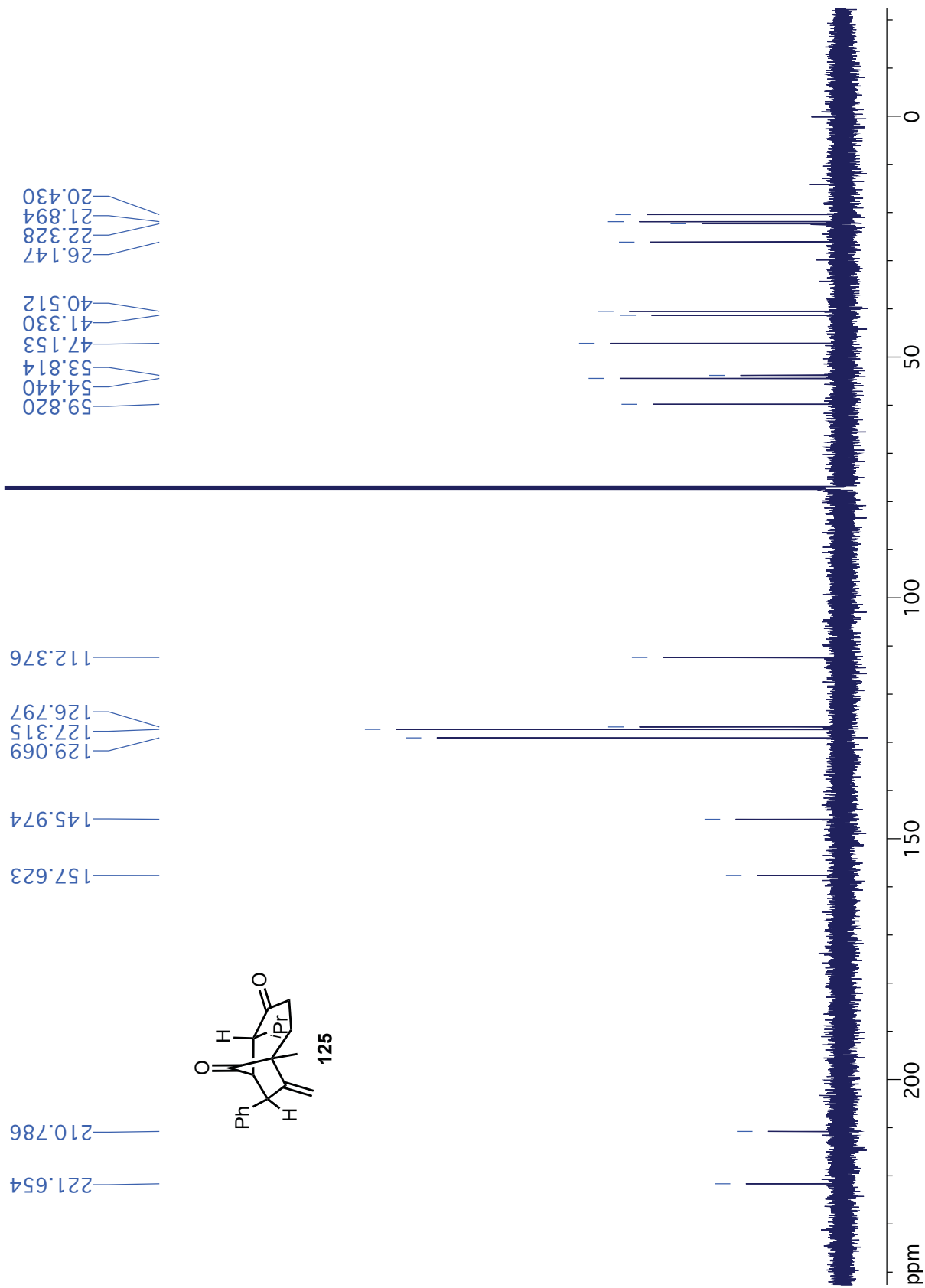

¹H NMR (CDCl₃, 500 MHz): (1*R**, 2*S**, 5*S**, 6*S**, 7*S**)-1,2,5-Trimethyl-8-methylene-7-phenylbicyclo[4.2.1]nonane-4,9-dione (126)

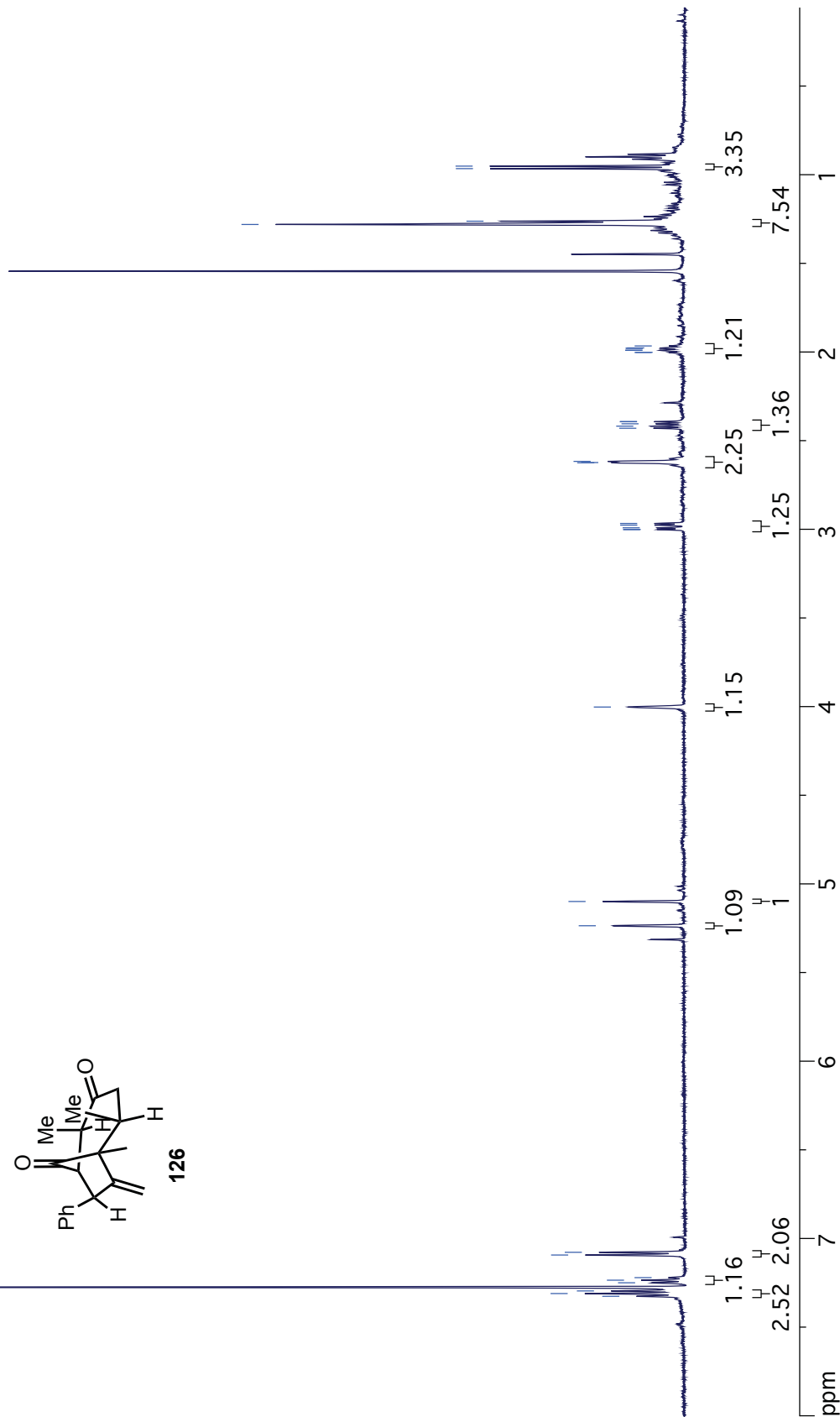
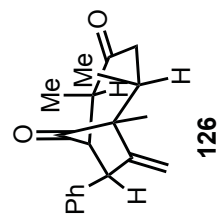

¹³C NMR (CDCl₃, 126 MHz): (1*R**,2*S**,5*S**,6*S**,7*S**)-1,2,5-Trimethyl-7-phenylbicyclo[4.2.1]nonane-4,9-dione (126)

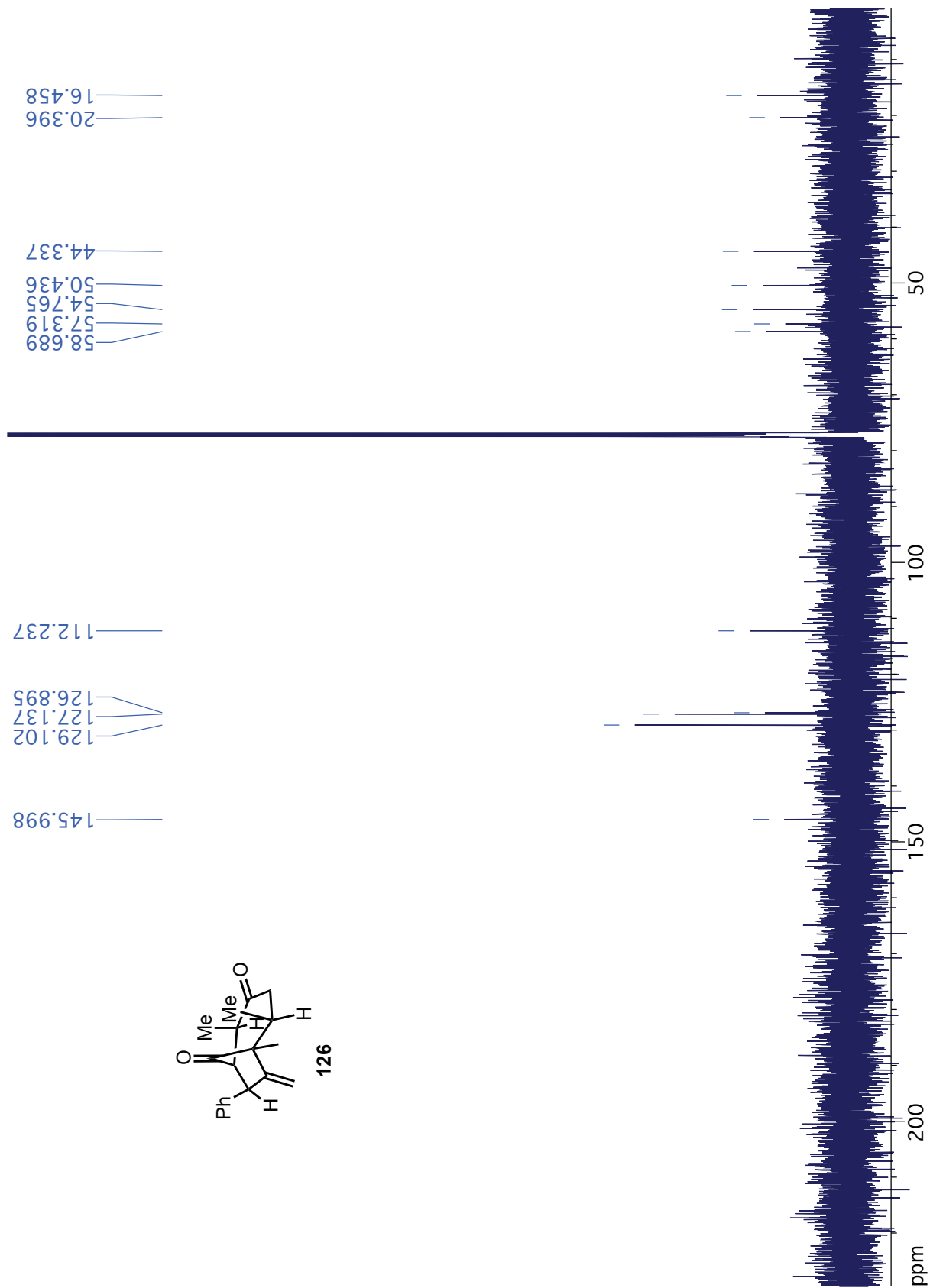

¹³C NMR (CDCl₃, 126 MHz): (4*R**,5*R**)-2,3-Dimethyl-5-((*R**,*E*)-3-oxohex-4-en-2-yl)-4-phenylcyclopent-2-enone (127)

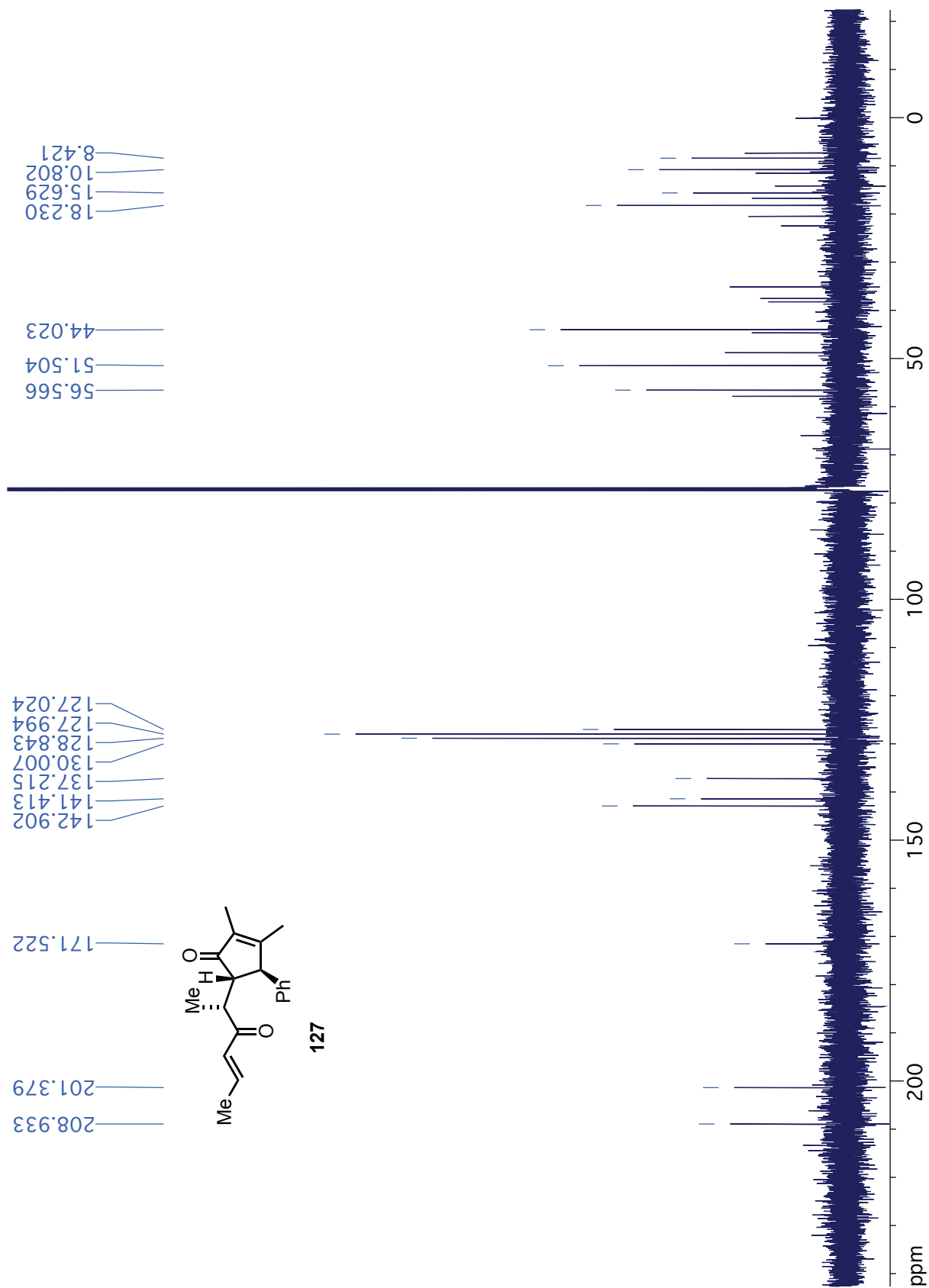

¹H NMR (CDCl₃, 500 MHz): (1*R**, 2*R**, 5*S**, 10*R**)-2,5,8-Trimethyl-10-phenylbicyclo[5.2.1]dec-7-ene-3,9-dione (128)

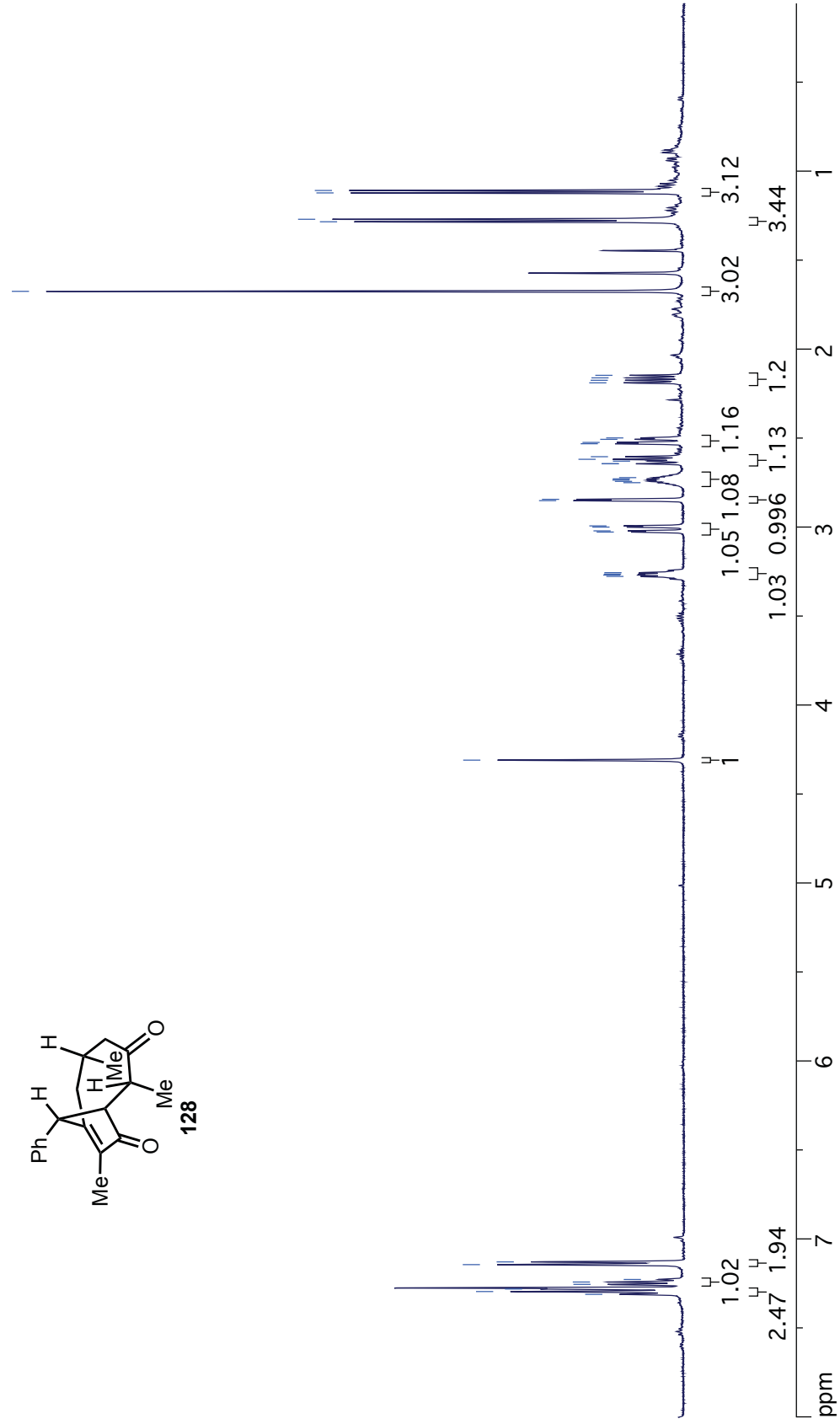
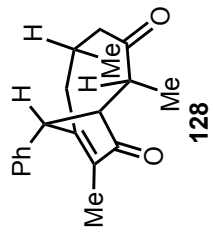
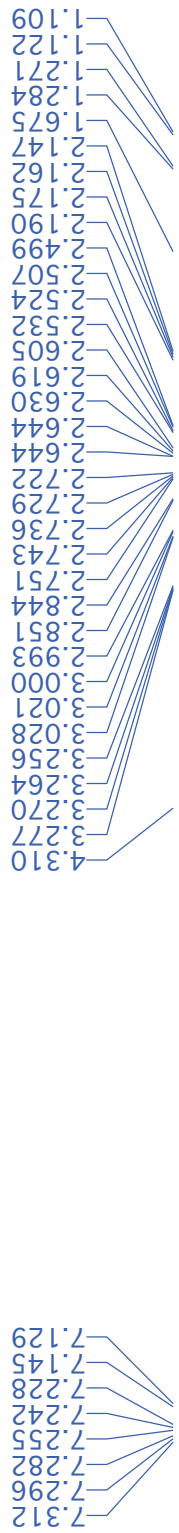

¹³C NMR (CDCl₃, 126 MHz): (1*R**,2*R**,5*S**,10*R**)-2,5,8-Trimethyl-10-phenylbicyclo[5.2.1]dec-7-ene-3,9-dione (128)

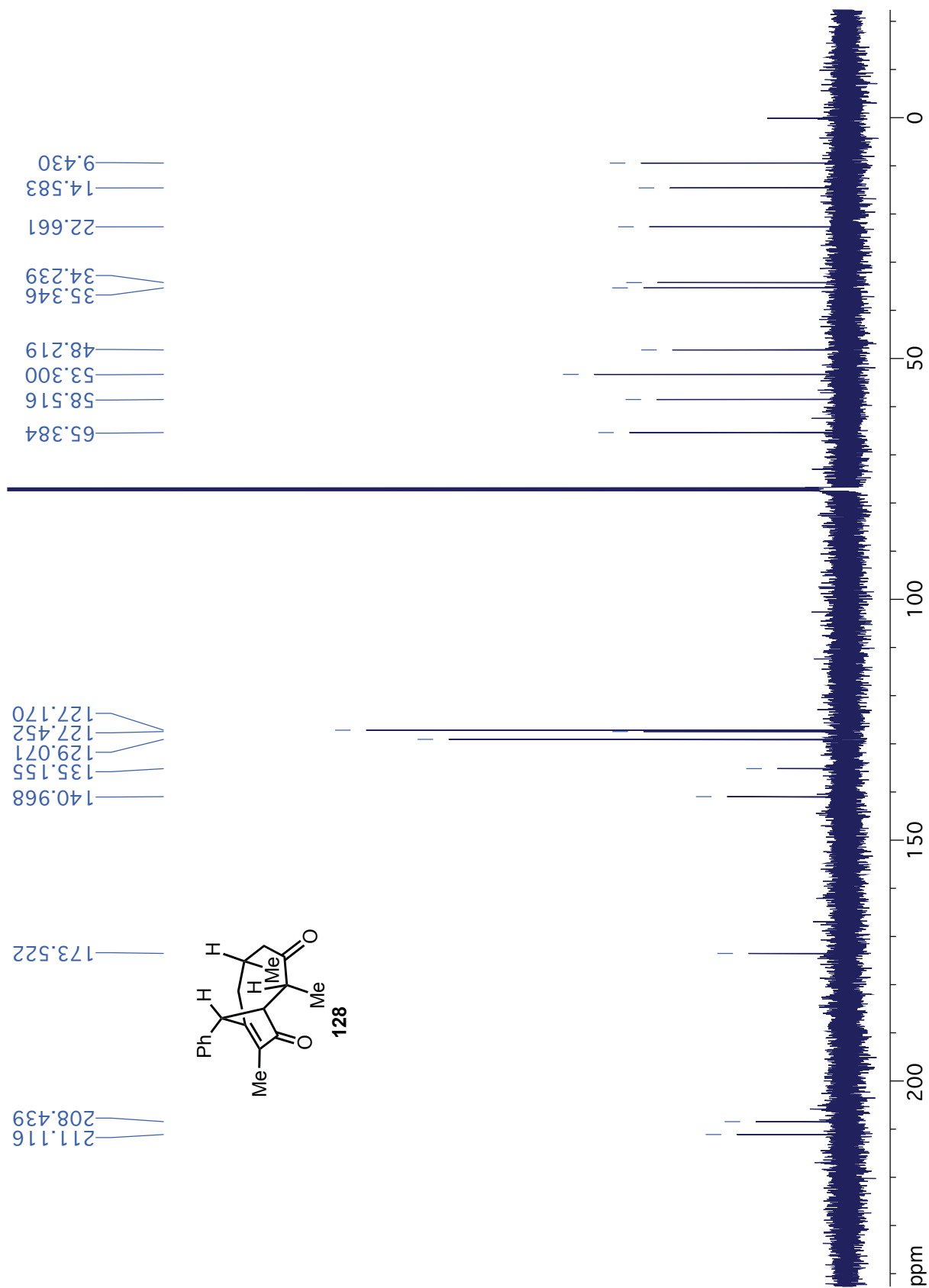

¹³C NMR (CDCl₃, 126 MHz): (1*R**, 2*R**, 5*R**, 6*S**, 7*S**)-1,2,5-Trimethyl-8-methylene-7-phenylbicyclo[4.2.1]nonane-4,9-dione (129)

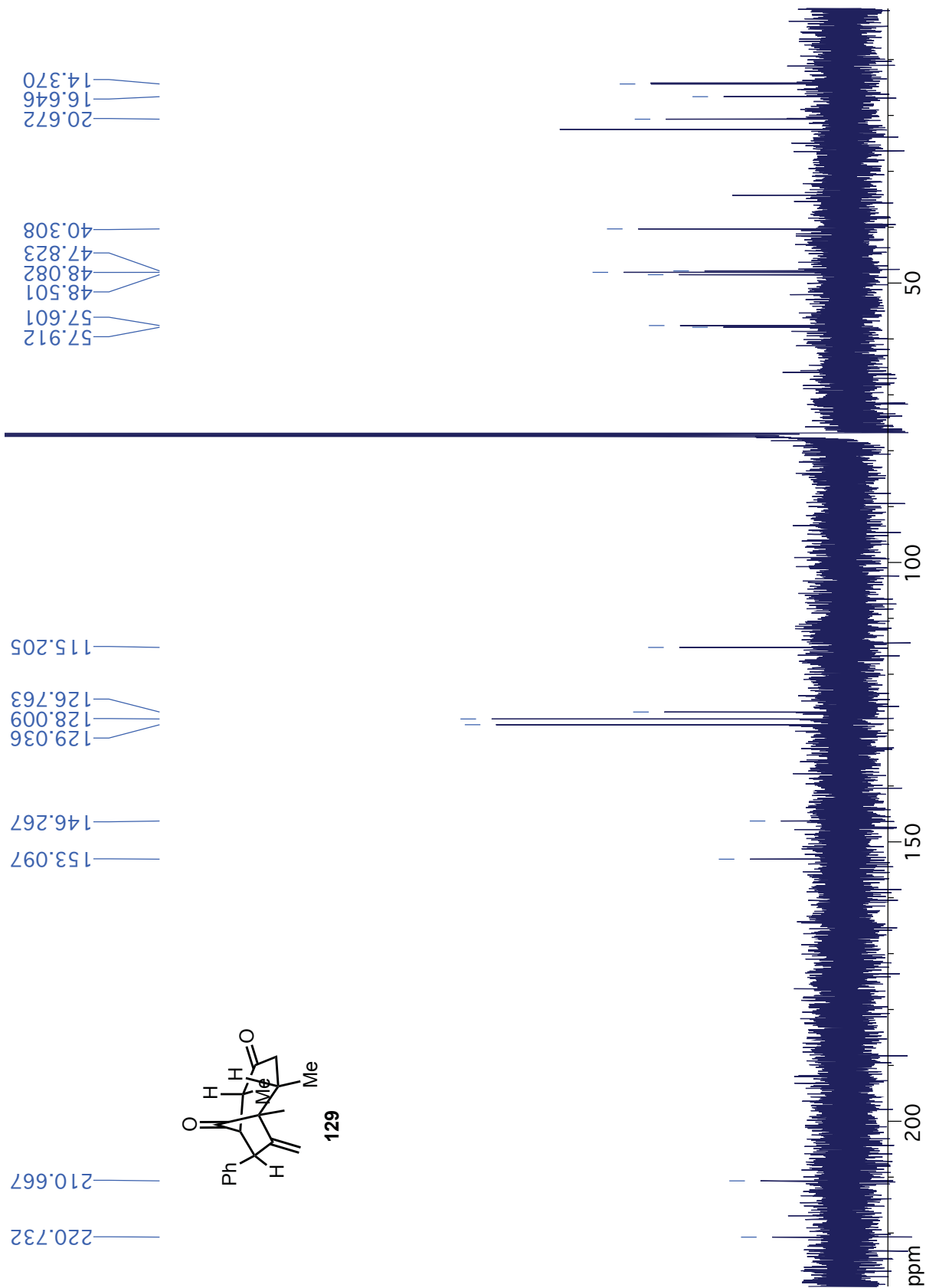

¹H NMR (CDCl₃, 500 MHz): (4*R**, 5*R**)-2,3-Dimethyl-5-((*S**, *E*)-3-oxohex-4-en-2-yl)-4-phenylcyclopent-2-enone (130)

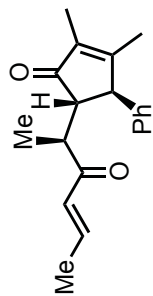

130

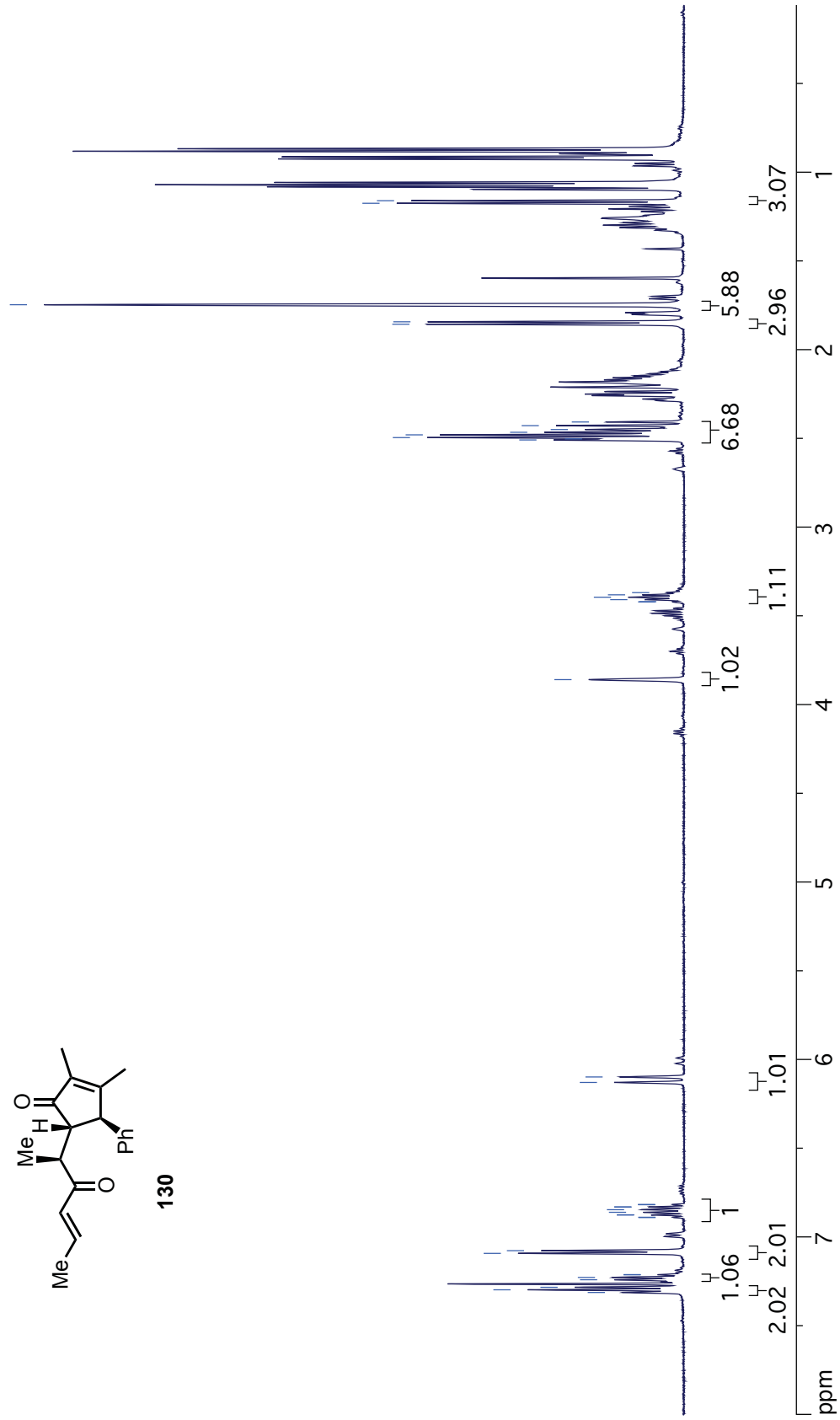

¹³C NMR (CDCl₃, 126 MHz): (4*R**,5*R**)-2,3-Dimethyl-5-((*S**,*E*)-3-oxohex-4-en-2-yl)-4-phenylcyclopent-2-enone (130)

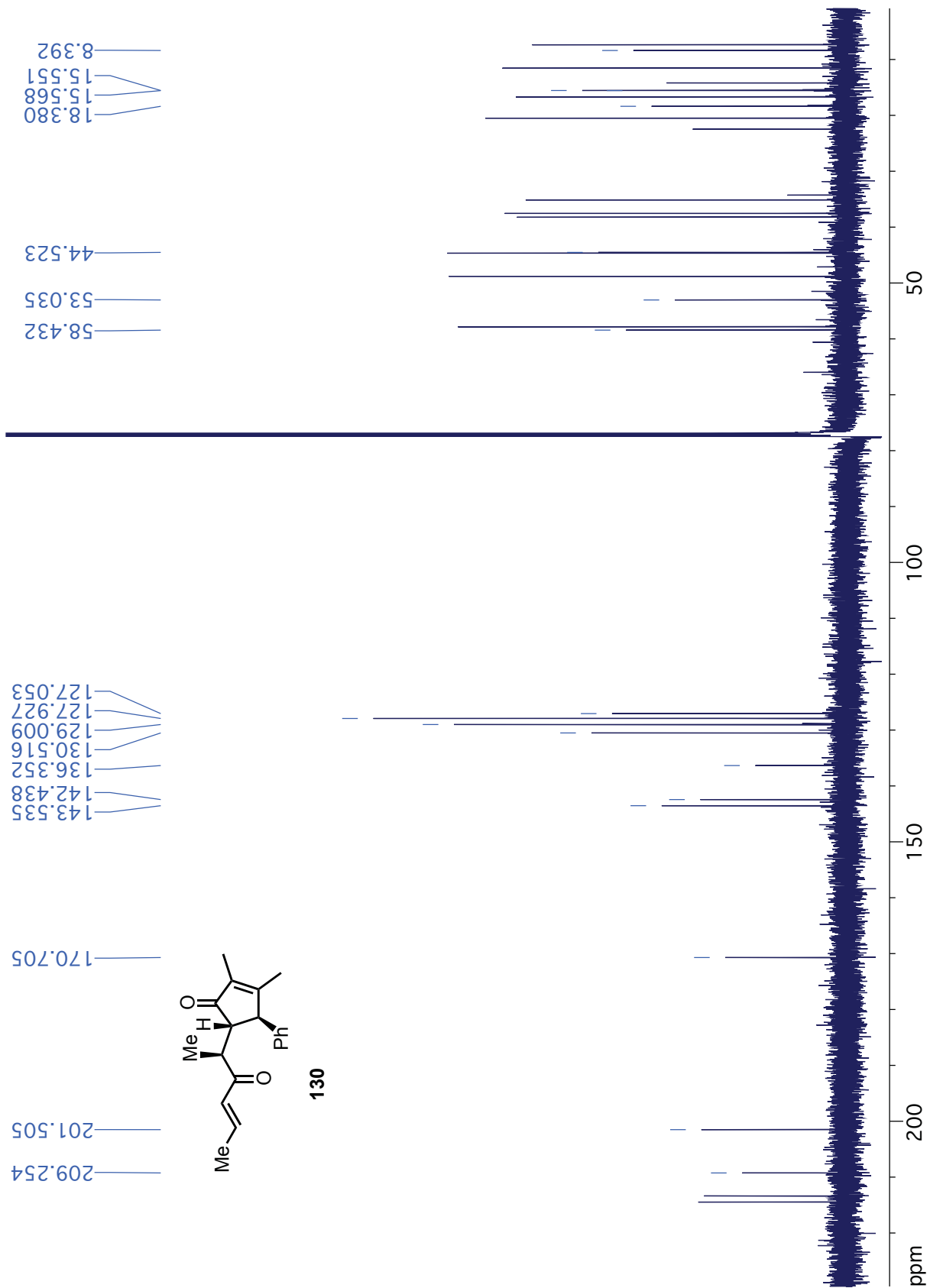

¹³C NMR (CDCl₃, 126 MHz): (1*R**,2*S**,5*S**,10*R**)-2,5,8-Trimethyl-10-phenylbicyclo[5.2.1]dec-7-ene-3,9-dione (131)

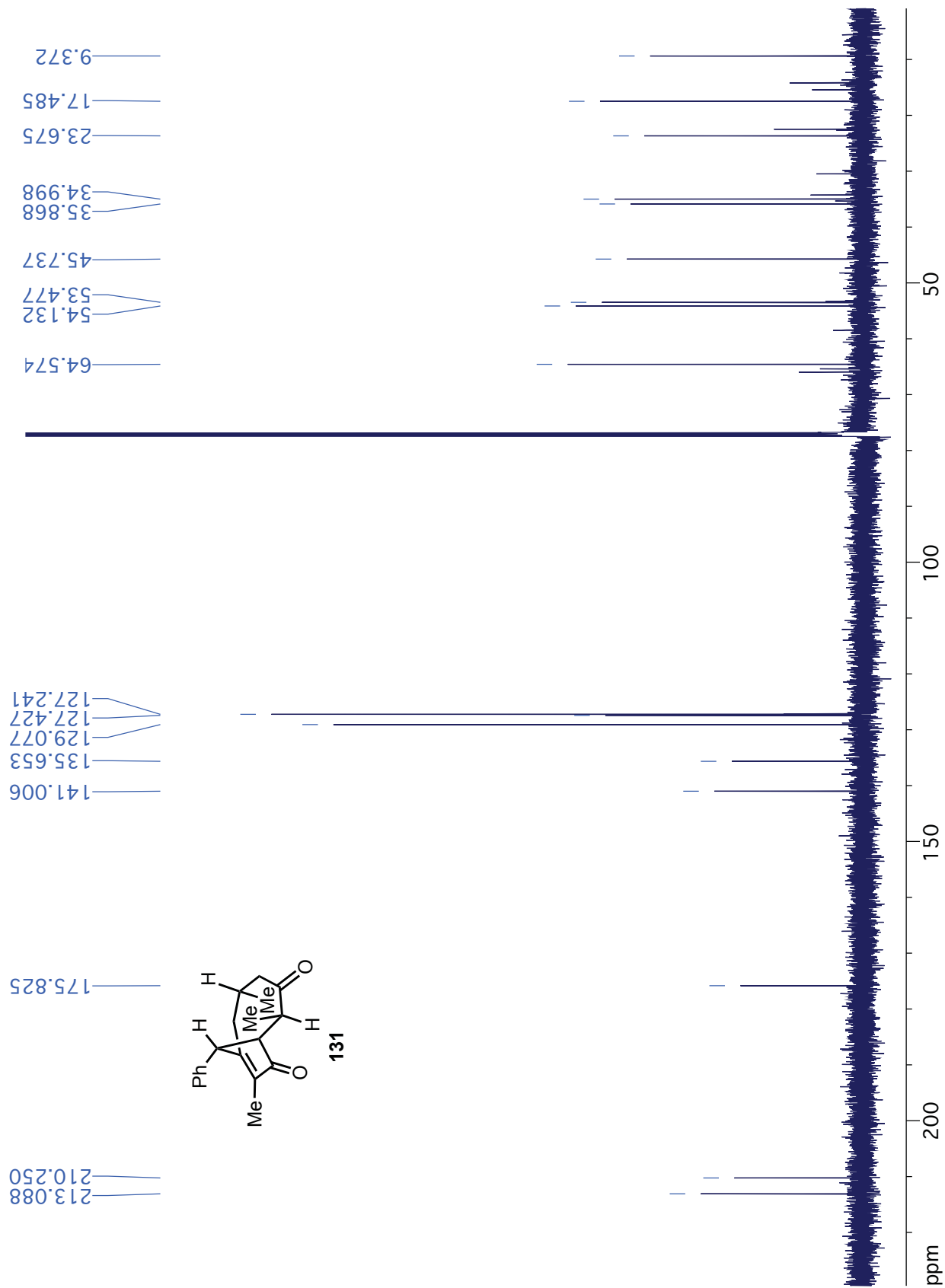

Appendix C: ^1H and ^{13}C NMR Spectra for Chapter 4

¹H NMR (CDCl₃, 500 MHz): (1*R,4*S**)-1,4,5,6,7,8-Hexahydro-1,4-epoxynaphthalene (184)**

2.382
2.371
2.362
2.352
2.342
2.332
2.322
1.857
1.848
1.838
1.830
1.828
1.819
1.808
1.687
1.674
1.666
1.656
1.642
1.636
1.634
1.622
1.495
1.485
1.482
1.471
1.460
1.450
1.442
1.428
1.424

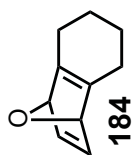

5.131

7.074

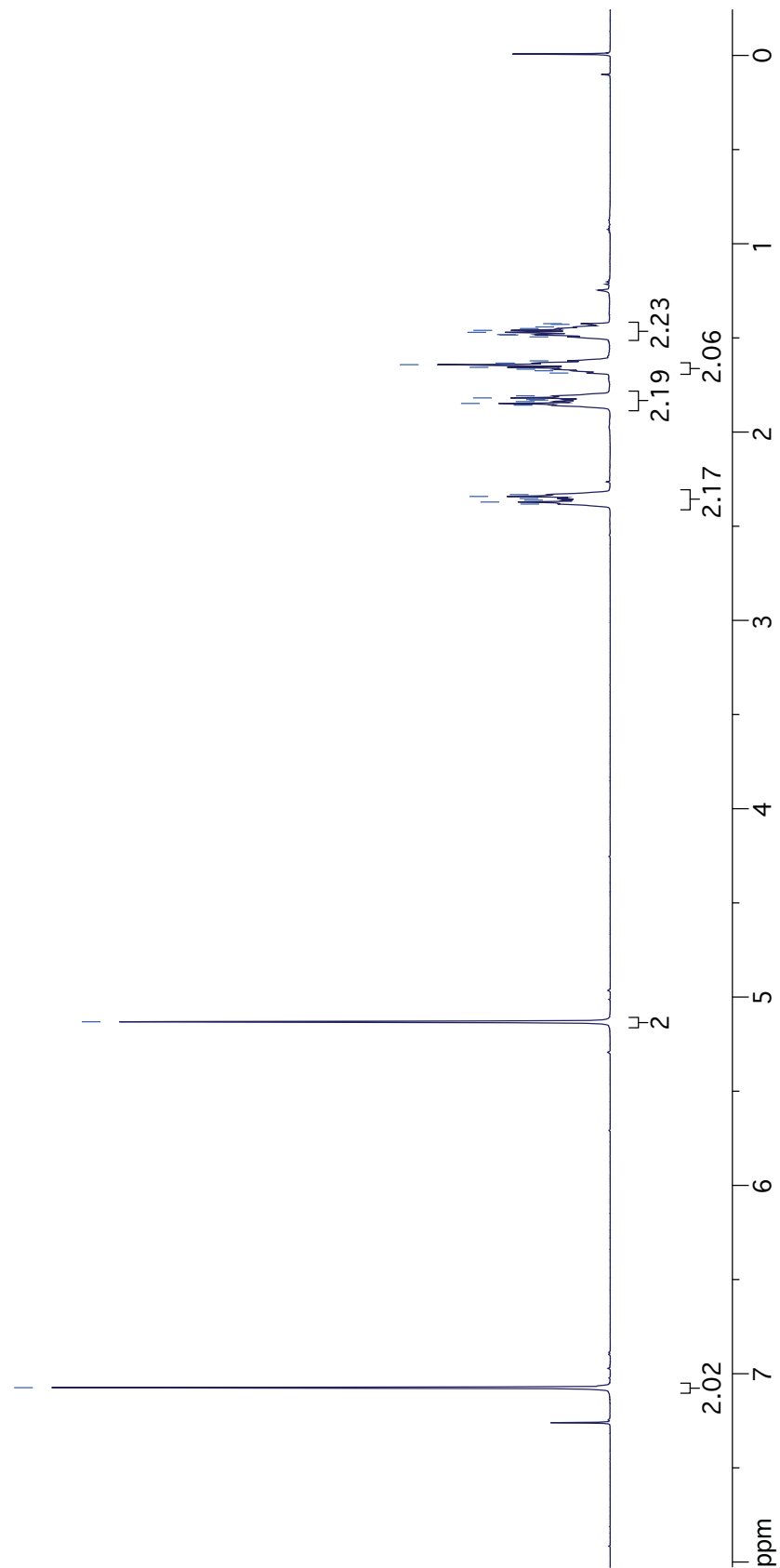

¹³C NMR (CDCl₃, 126 MHz): (1*R,4*S**)-1,4,5,6,7,8-Hexahydro-1,4-epoxynaphthalene (184)**

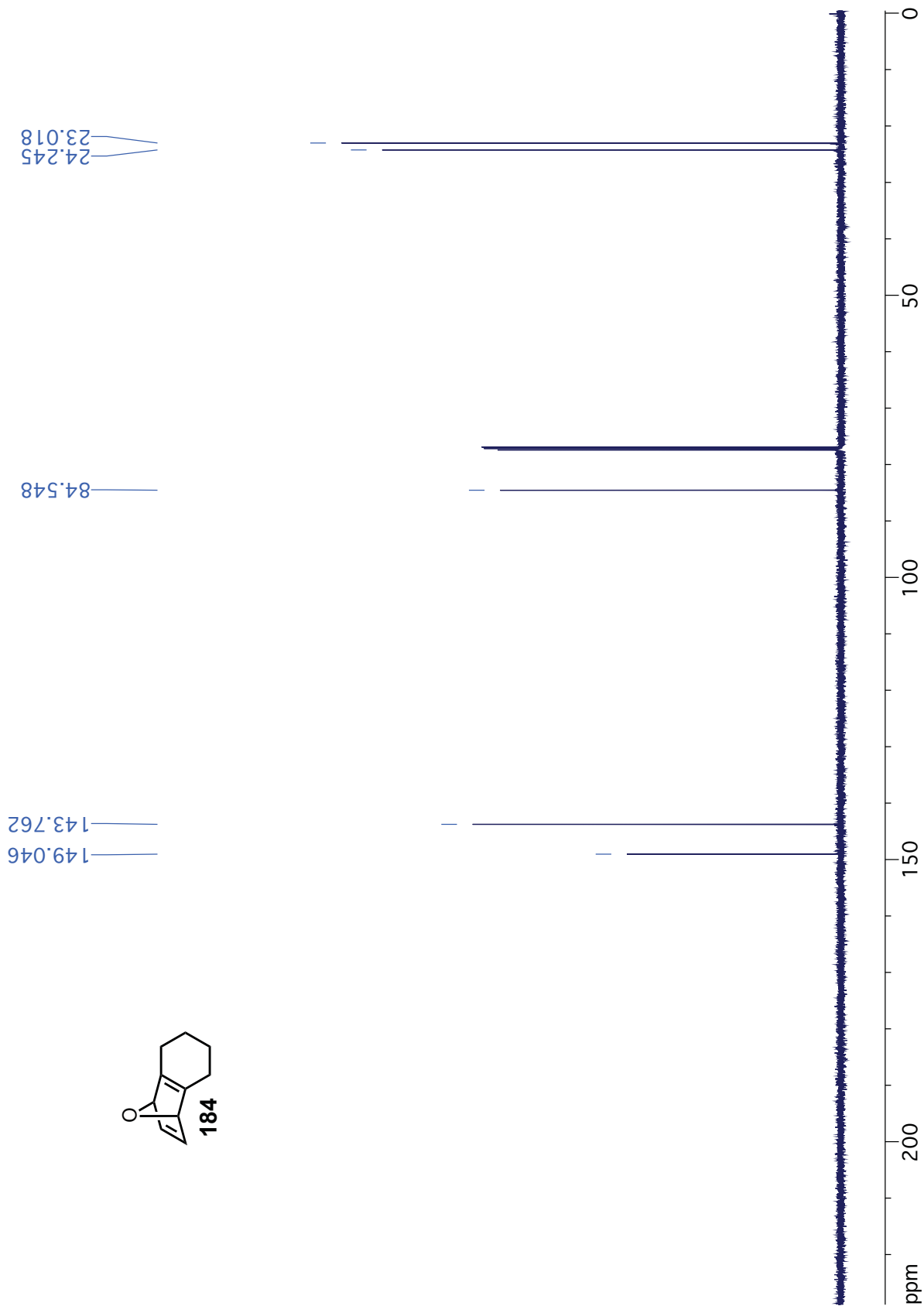
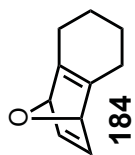

¹H NMR (CDCl₃, 500 MHz): 1,4,5,6,7,8-Hexahydronaphthalen-2-yl acetate (188)

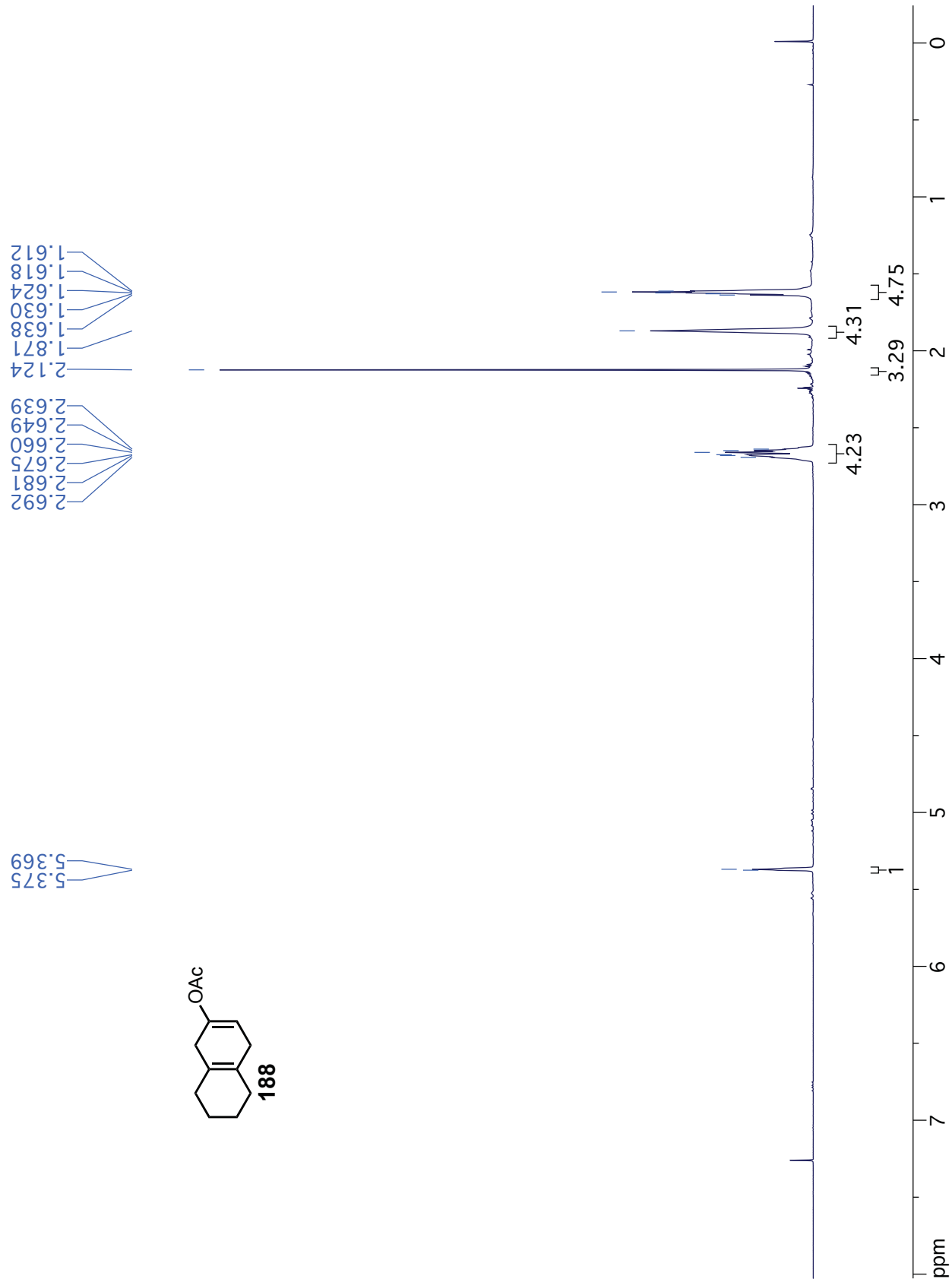
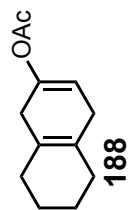

¹³C NMR (CDCl₃, 126 MHz): 1,4,5,6,7,8-Hexahydronaphthalen-2-yl acetate (188)

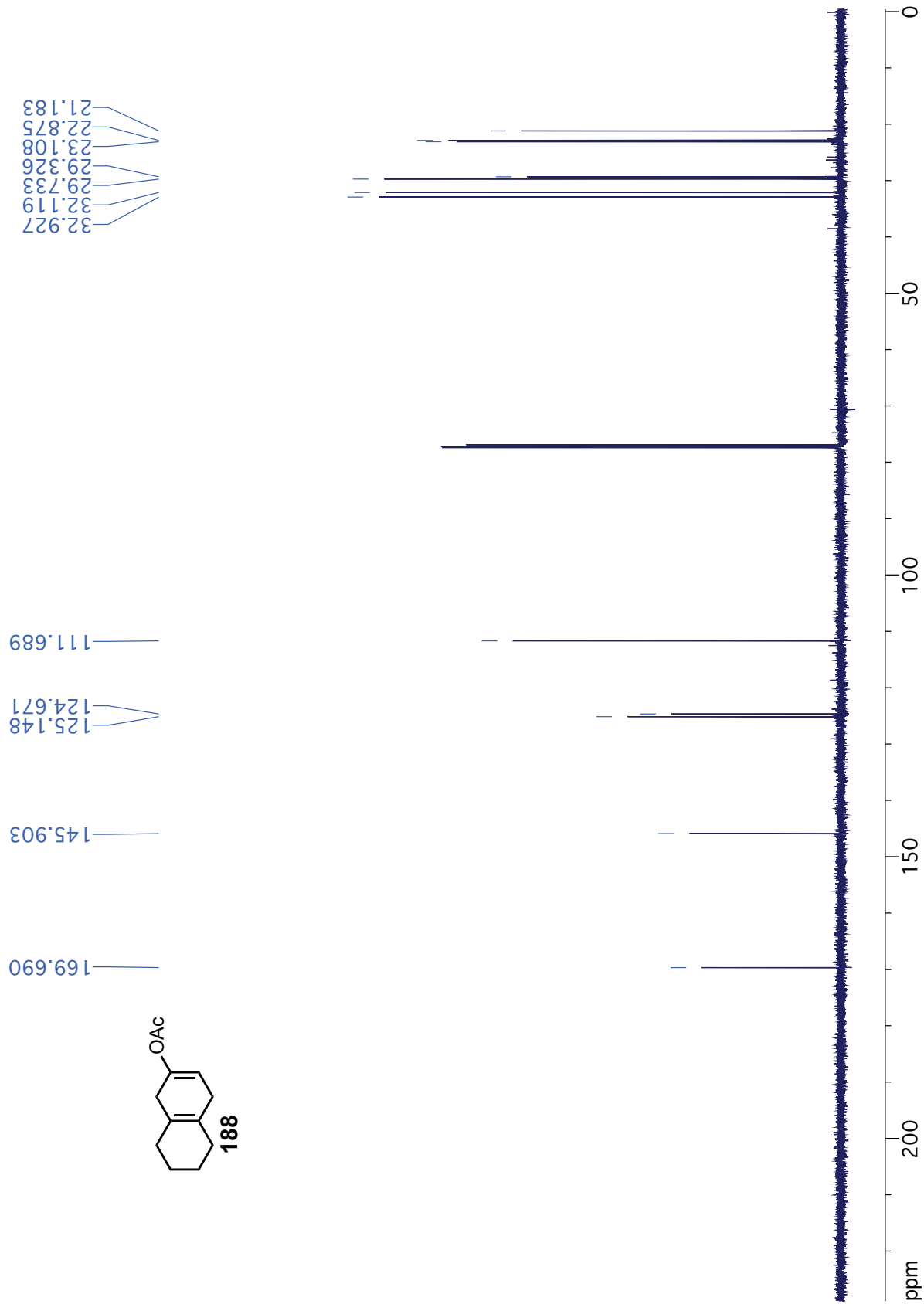

¹H NMR (CDCl₃, 500 MHz): (1*R,4*S**)-1,4,5,6,7,8-Hexahydro-1,4-ethanonaphthalene (189)**

2.049
1.561
1.560
1.546
1.542
1.536
1.529
1.517
1.512
1.290
1.279
1.261
1.245
1.228
1.217

3.230

6.309
6.302
6.294

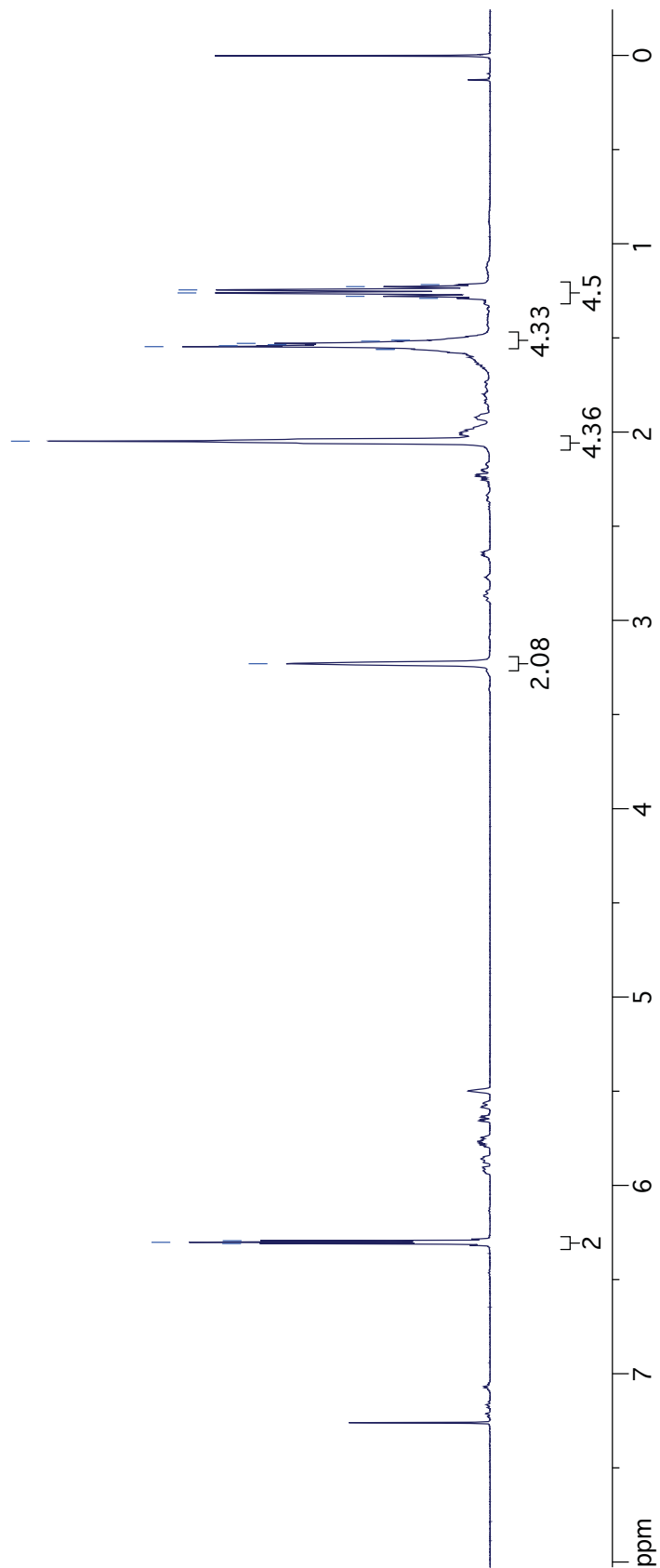
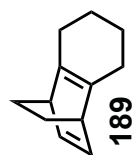

¹³C NMR (CDCl₃, 126 MHz): (1*R,4*S**)-1,4,5,6,7,8-Hexahydro-1,4-ethanonaphthalene (189)**

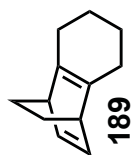
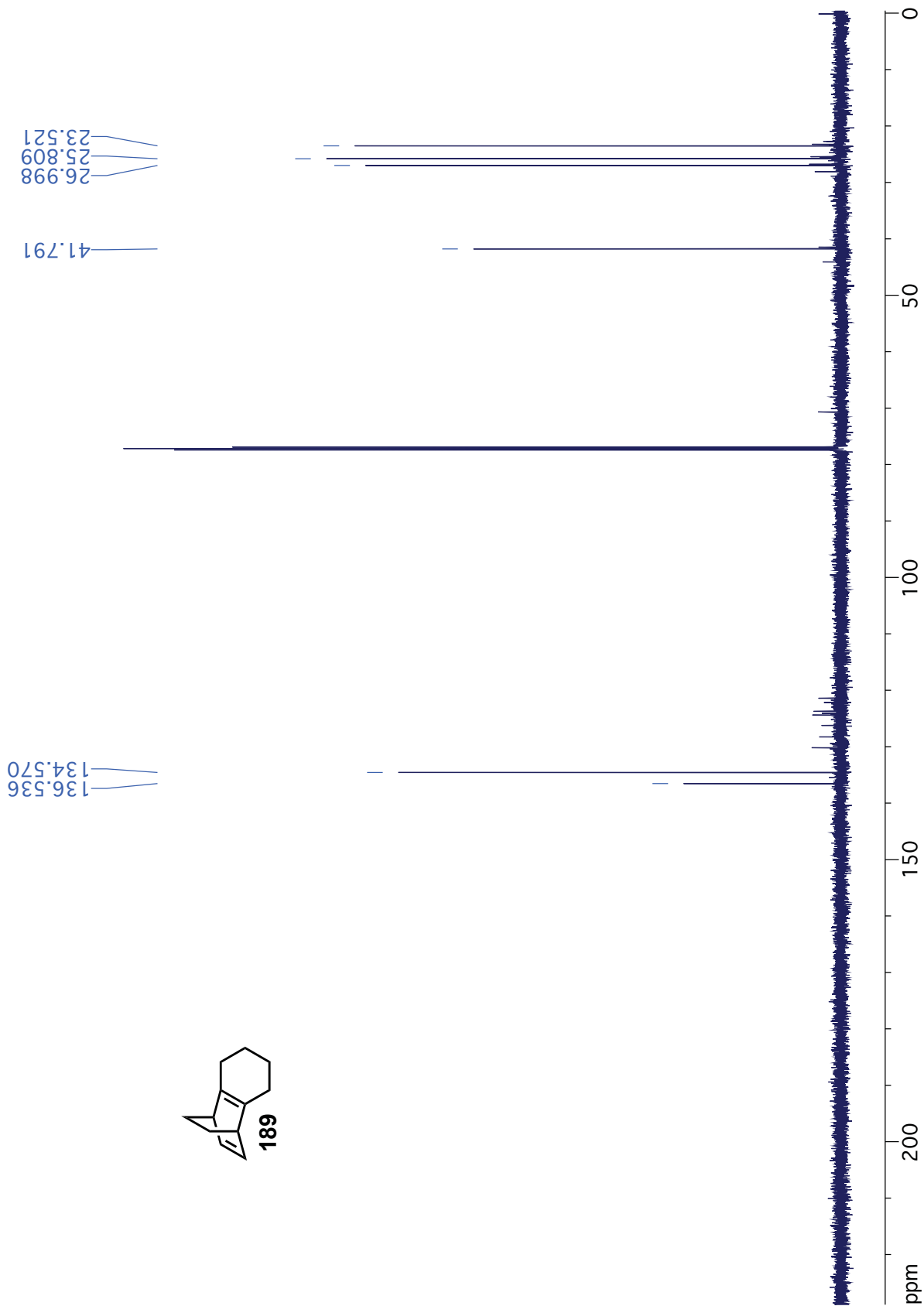

¹H NMR (CDCl₃, 500 MHz): 2-Bromo-6,6-dimethylcyclohex-2-en-1-one (204)

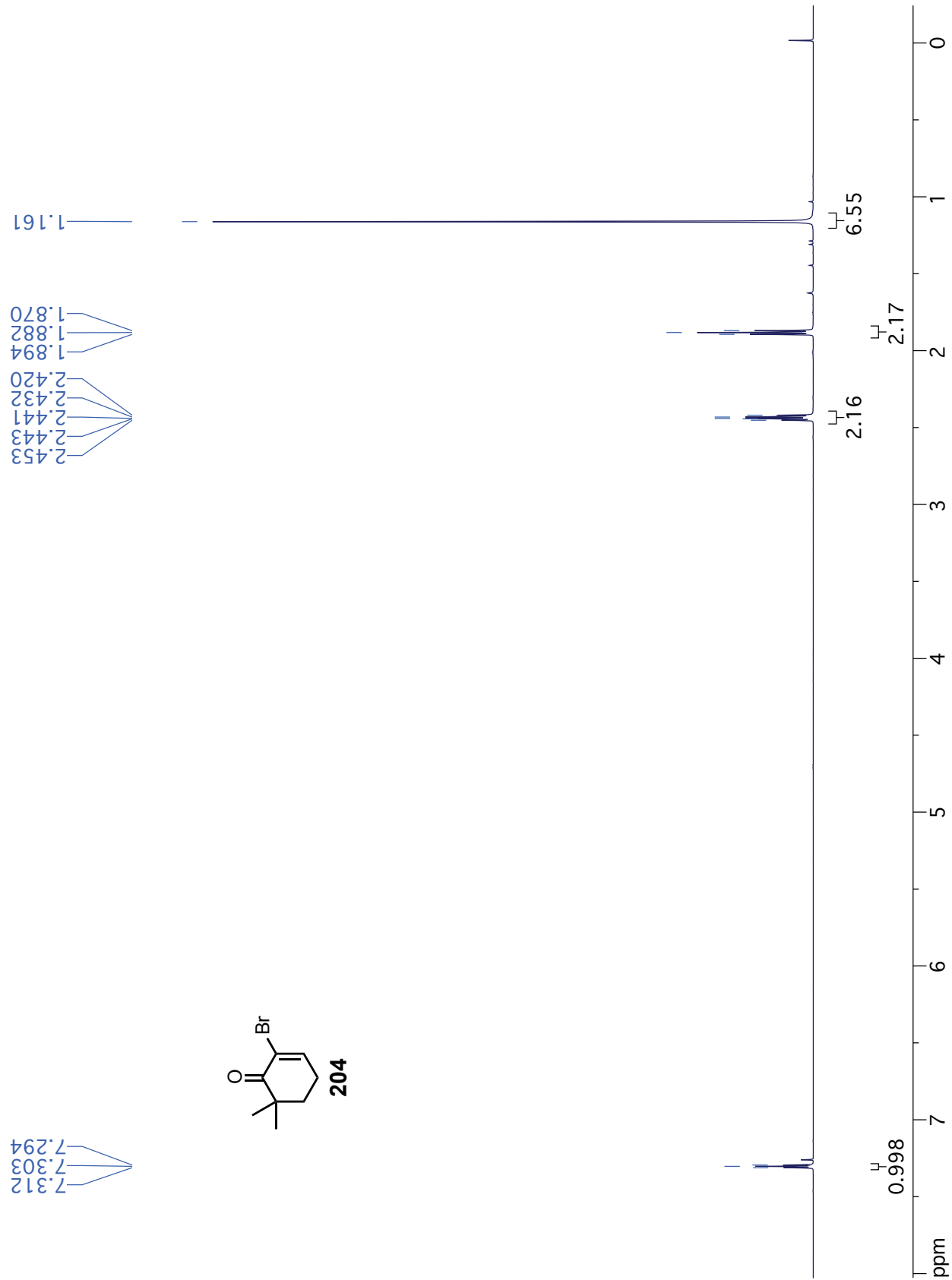

¹³C NMR (CDCl₃, 126 MHz): 2-Bromo-6,6-dimethylcyclohex-2-en-1-one (204)

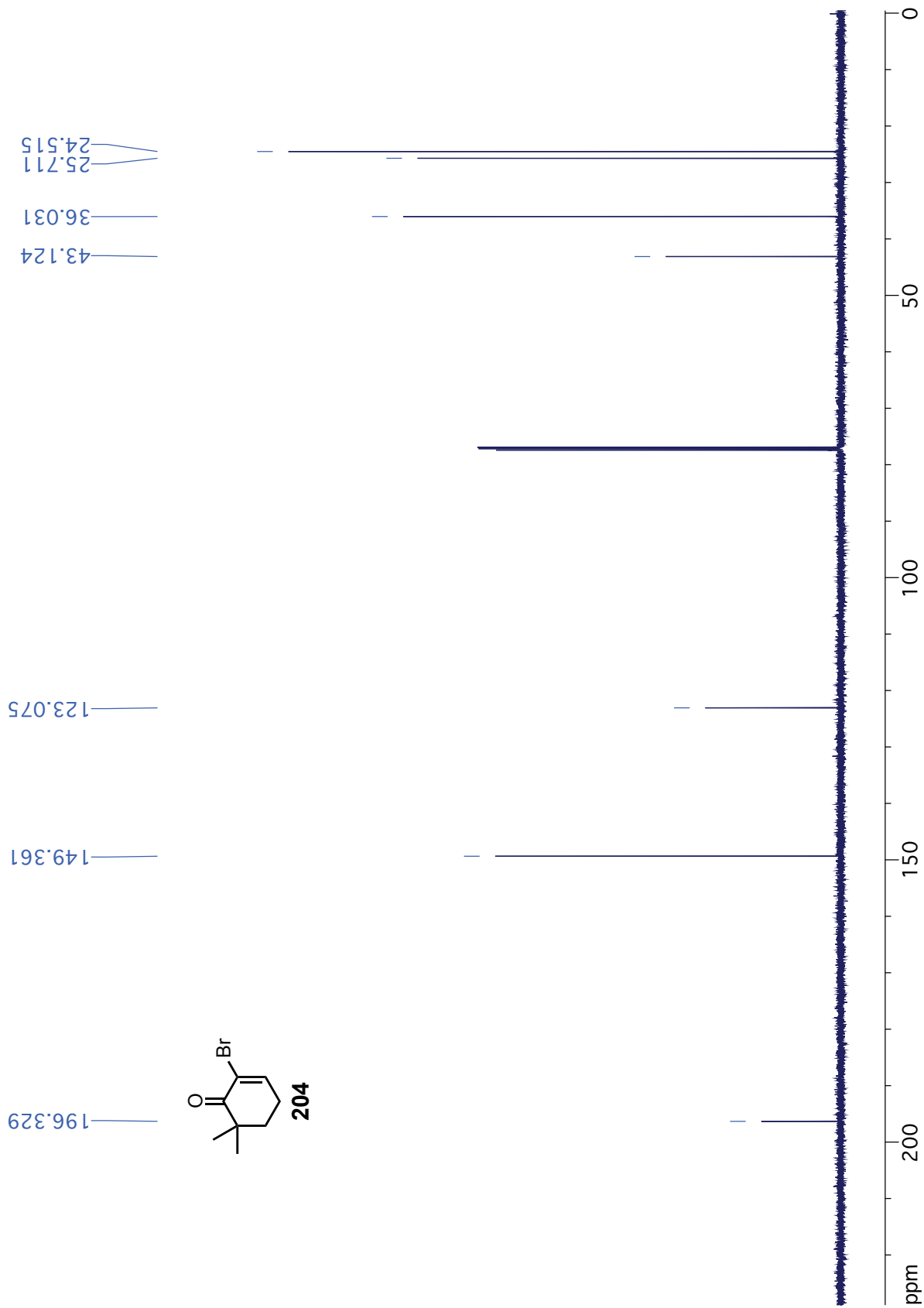

¹³C NMR (CDCl₃, 126 MHz): 6-Methyl-2-(trimethylsilyl)cyclohex-2-en-1-one (207)

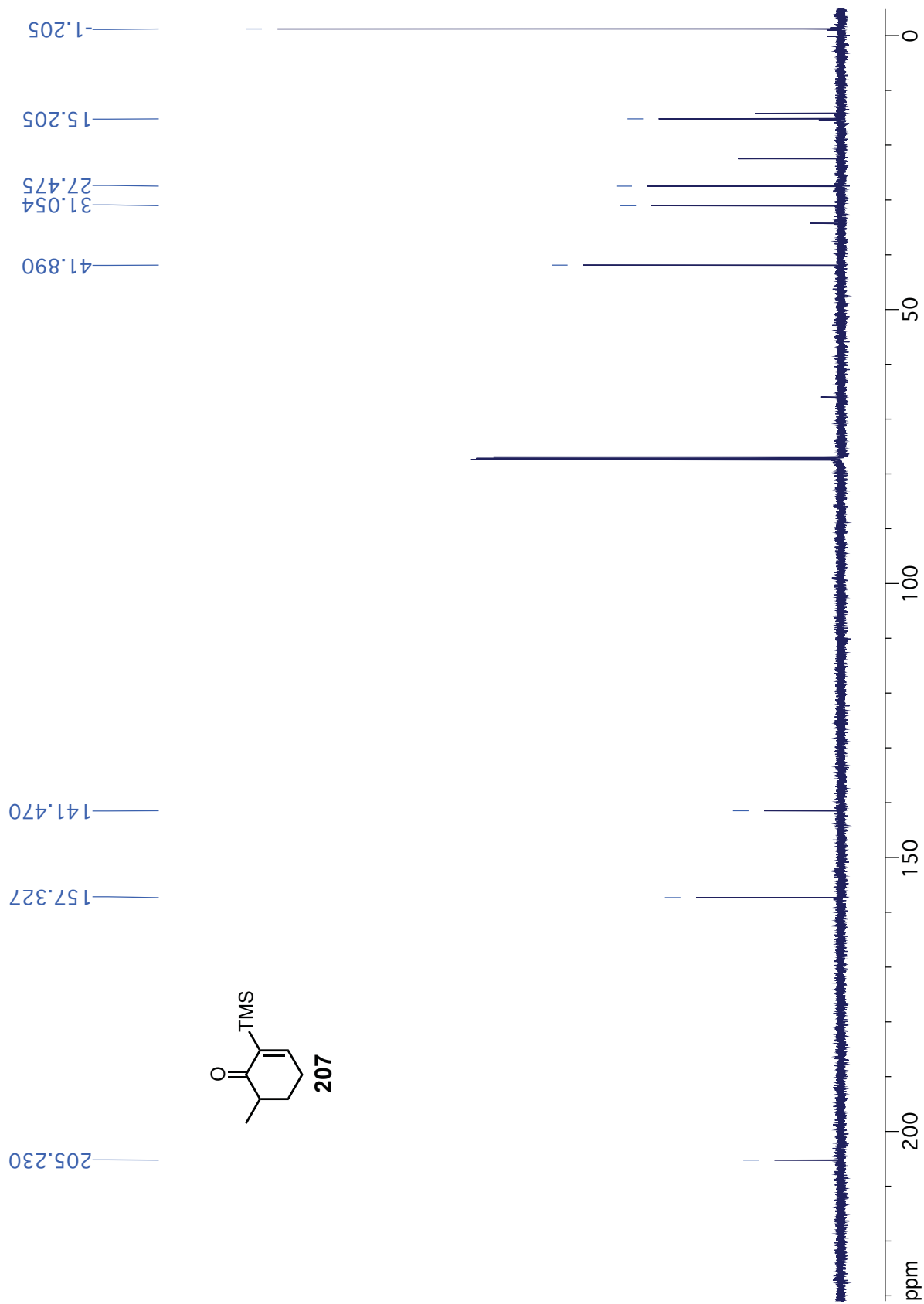

¹H NMR (CDCl₃, 500 MHz): 6,6-Dimethyl-2-(trimethylsilyl)cyclohex-2-en-1-one (208)

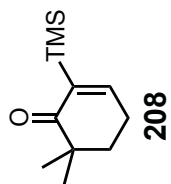
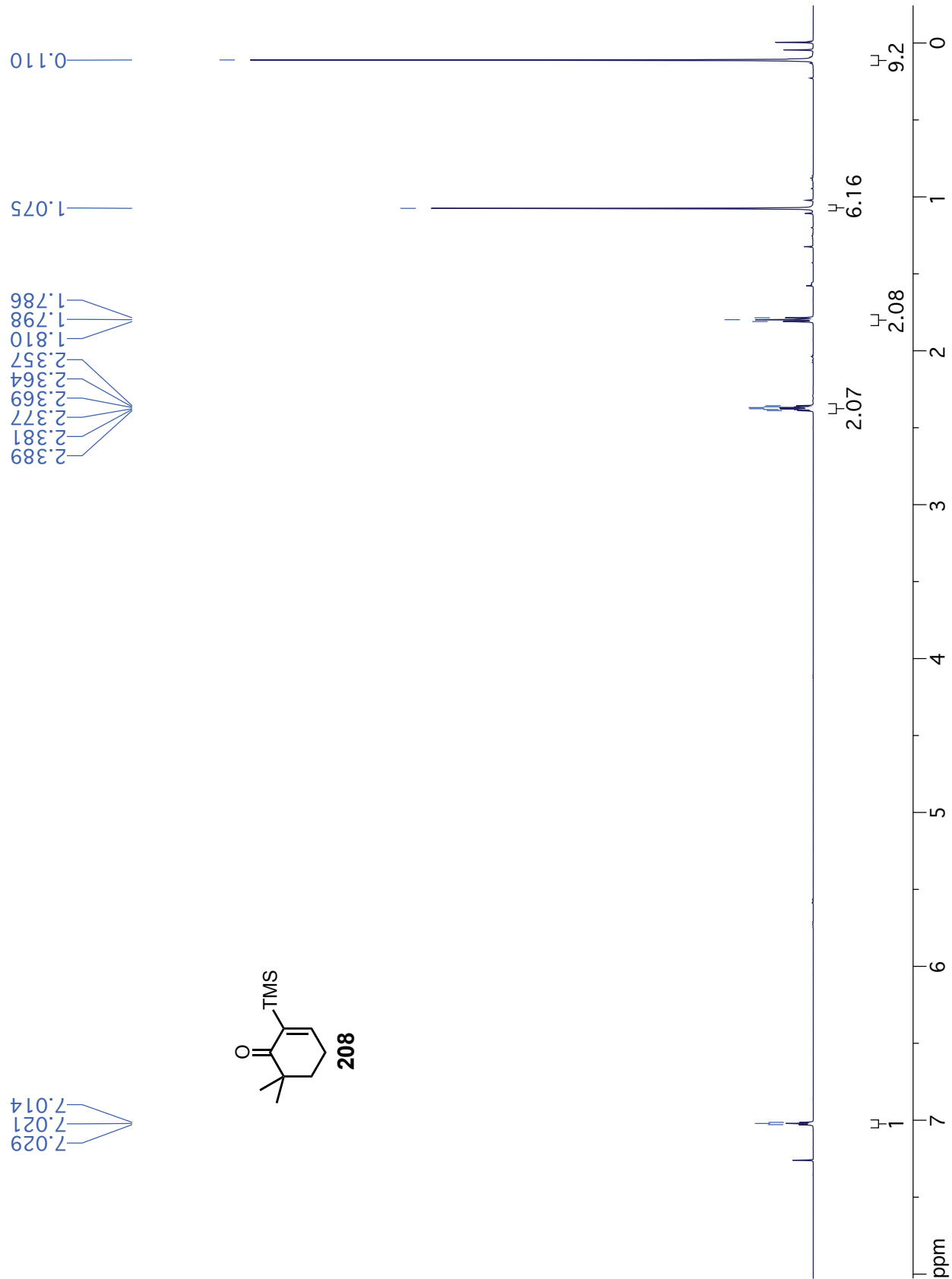

¹H NMR (CDCl₃, 500 MHz): 3-Methyl-2-(trimethylsilyl)cyclohex-1-en-1-yl trifluoromethanesulfonate (219)

2.561
2.558
2.551
2.548
2.545
2.541
2.534
2.531
2.418
2.410
2.404
2.396
2.379
2.362
1.881
1.875
1.868
1.861
1.855
1.848
1.841
1.836
1.830
1.723
1.716
1.639
1.632
1.622
1.613
1.605
1.602
1.596
1.588
1.581
1.578
1.571
1.452
1.445
1.441
1.438
1.434
1.427
1.418
1.414
1.412
1.407
1.075
1.061
0.220

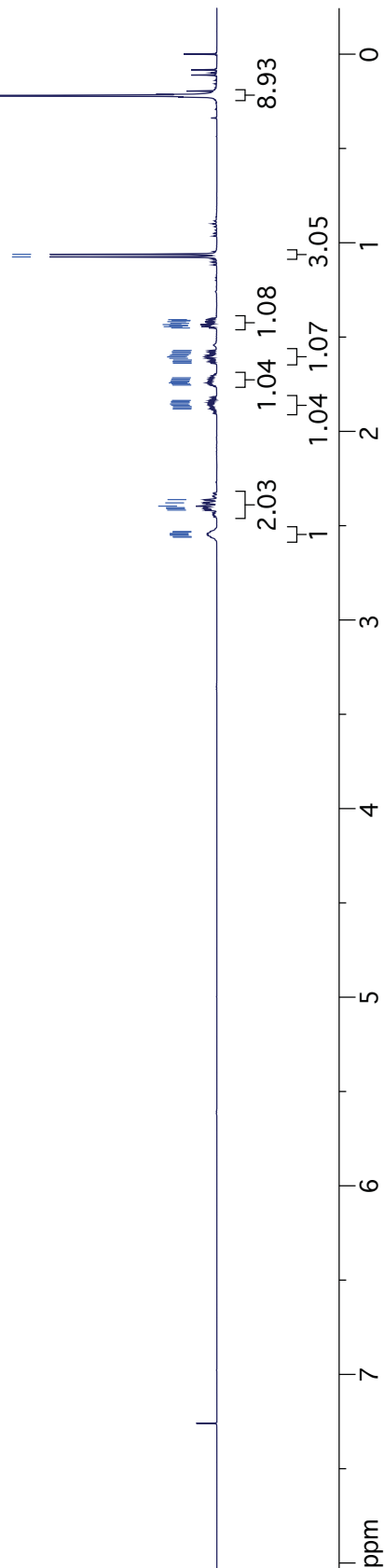
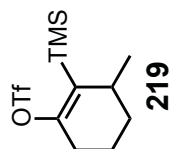

¹³C NMR (CDCl₃, 126 MHz): 3-Methyl-2-(trimethylsilyl)cyclohex-1-en-1-yl trifluoromethanesulfonate (219)

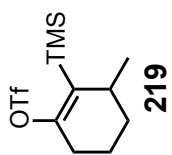
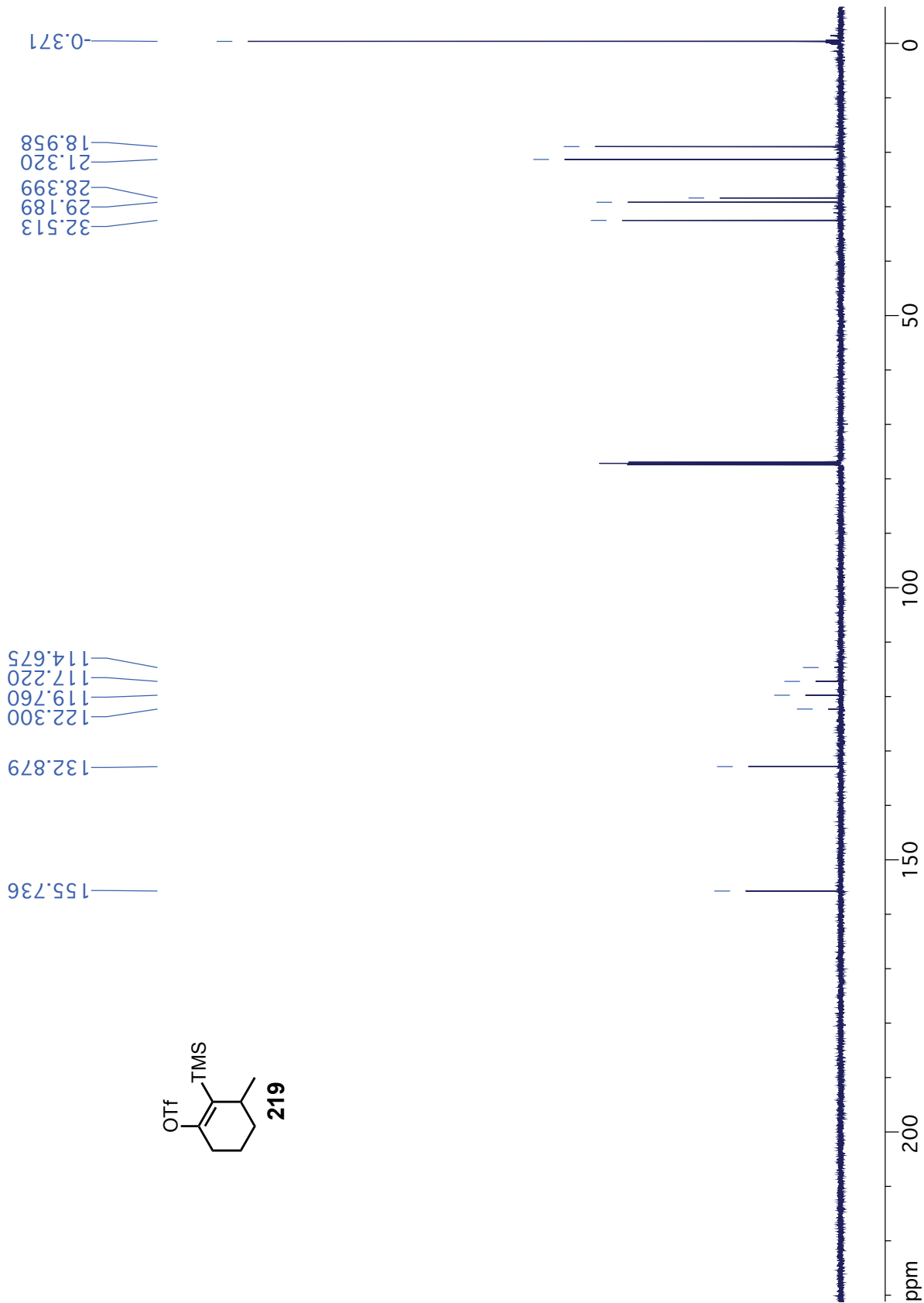

¹H NMR (CDCl₃, 500 MHz): (8a*R**,8b*S**,12b*R**,12c*S**)-1,5,12,16-Tetramethyl-1,2,3,4,5,6,7,8,9,10,11,12-dodecahydro-8b,12b-butanobenzo[3',4']cyclobuta[1,2-*e*]biphenylene (224)

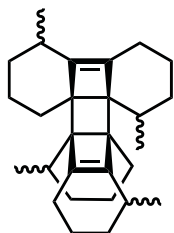
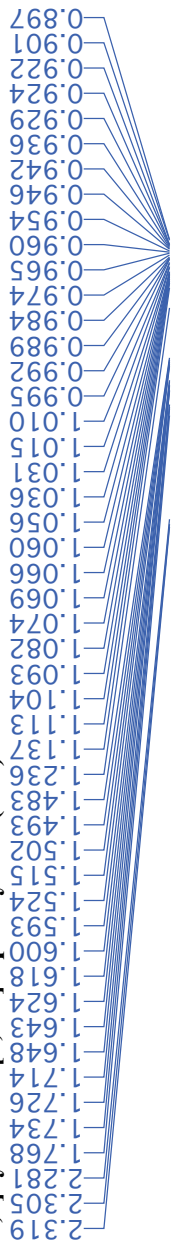

224

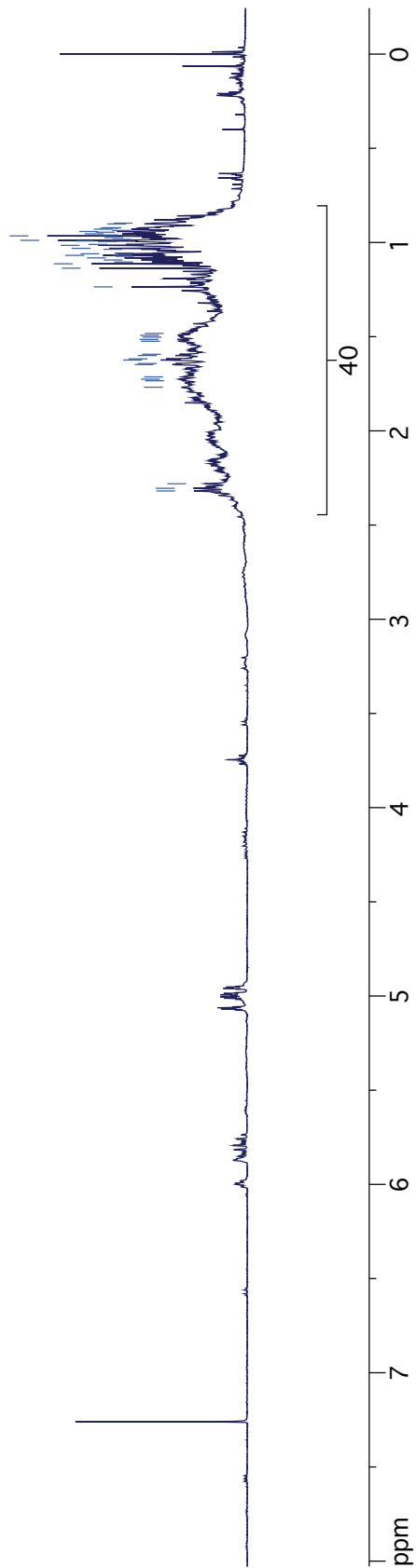

¹H NMR (CDCl₃, 500 MHz): (1*R,4*S**)-5-Methyl-1,4,5,6,7,8-hexahydro-1,4-epoxynaphthalene (225)**

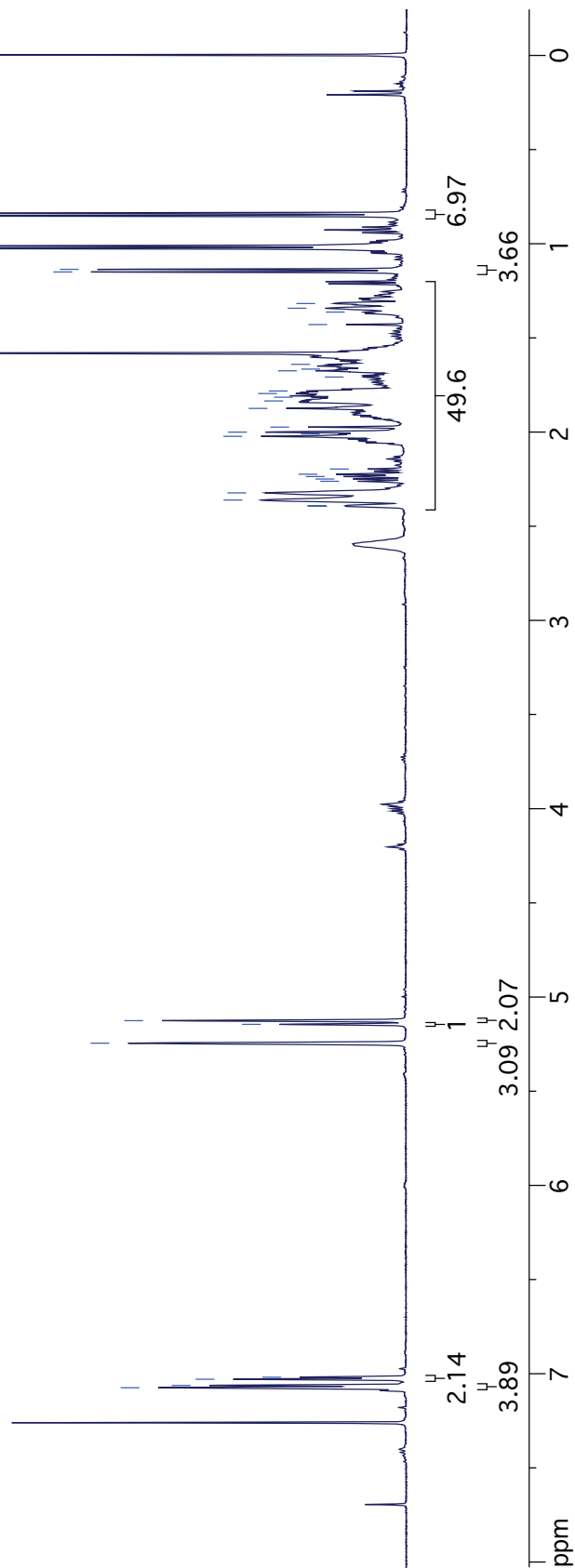
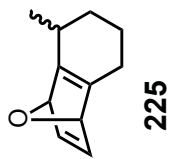
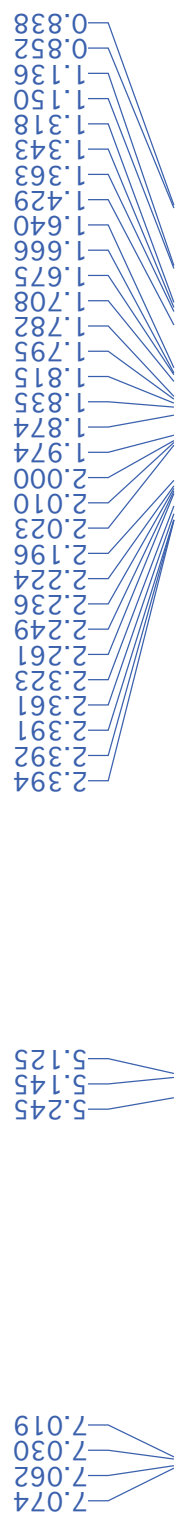

¹³C NMR (CDCl₃, 126 MHz): (1*R,4*S**)-5-Methyl-1,4,5,6,7,8-hexahydro-1,4-epoxynaphthalene (225)**

32.112
31.826
30.026
28.716
24.543
24.268
21.821
21.375
19.796
16.819

84.827
84.606
83.910
82.591

153.696
152.280
149.310
148.534
144.286
144.250
143.714
143.552

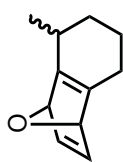

225

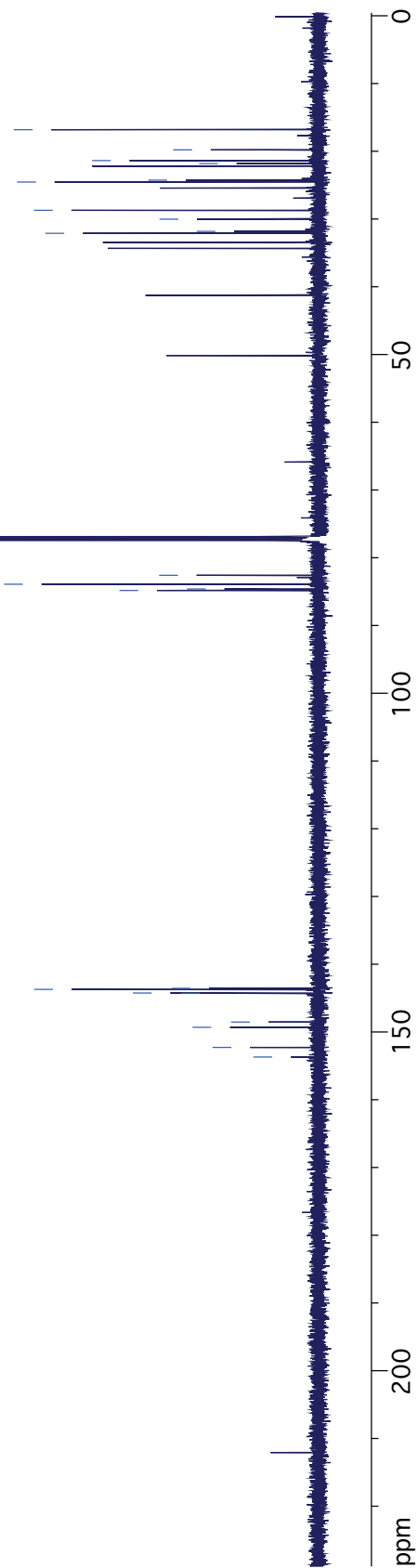

¹H NMR (CDCl₃, 500 MHz): 2-Iodocyclohex-1-en-1-yl trifluoromethanesulfonate (236)

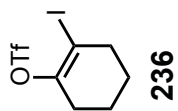

2.722
2.717
2.710
2.705
2.700
2.693
2.688
2.481
2.476
2.469
2.463
2.458
2.451
2.446
1.883
1.876
1.871
1.864
1.859
1.852
1.847
1.840
1.834
1.713
1.707
1.701
1.695
1.689
1.683
1.677
1.671
1.665

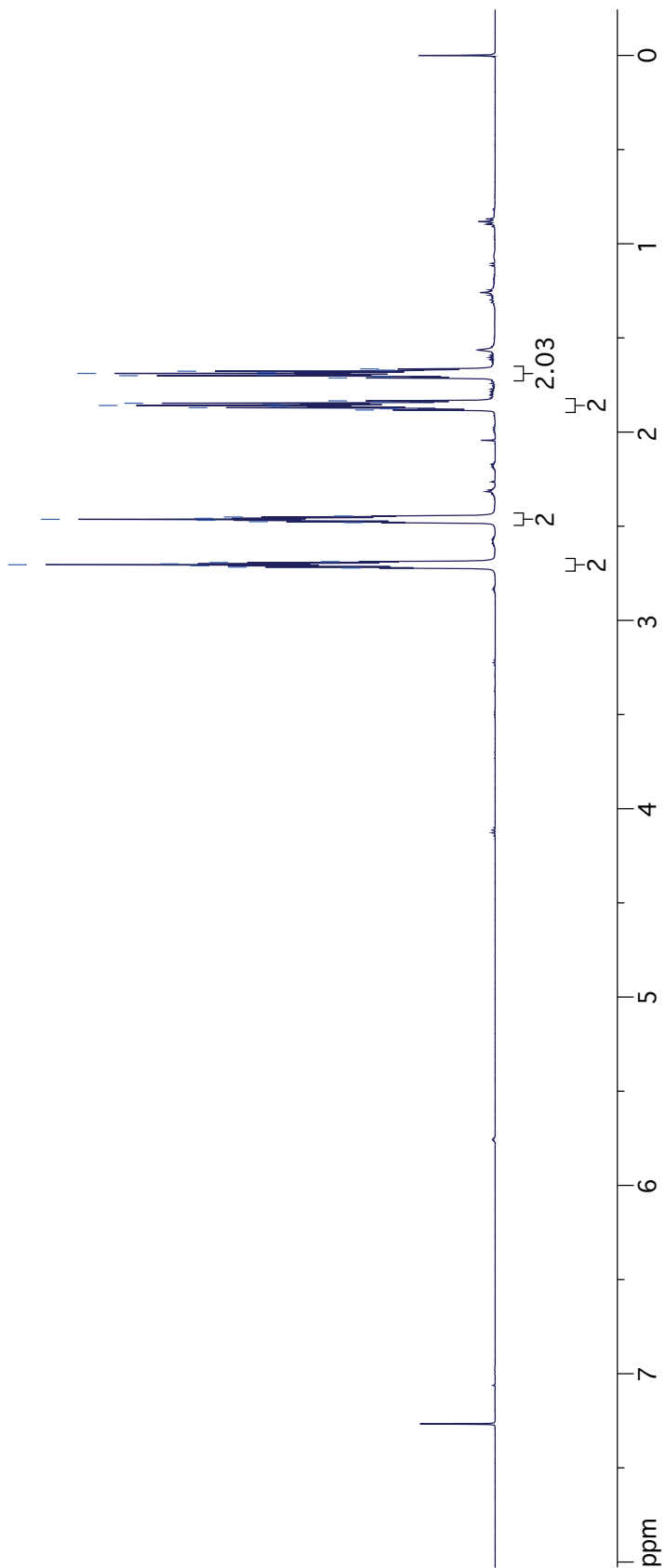

¹³C NMR (CDCl₃, 126 MHz): 2-Iodocyclohex-1-en-1-yl trifluoromethanesulfonate (236)

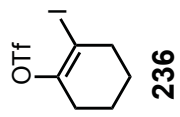
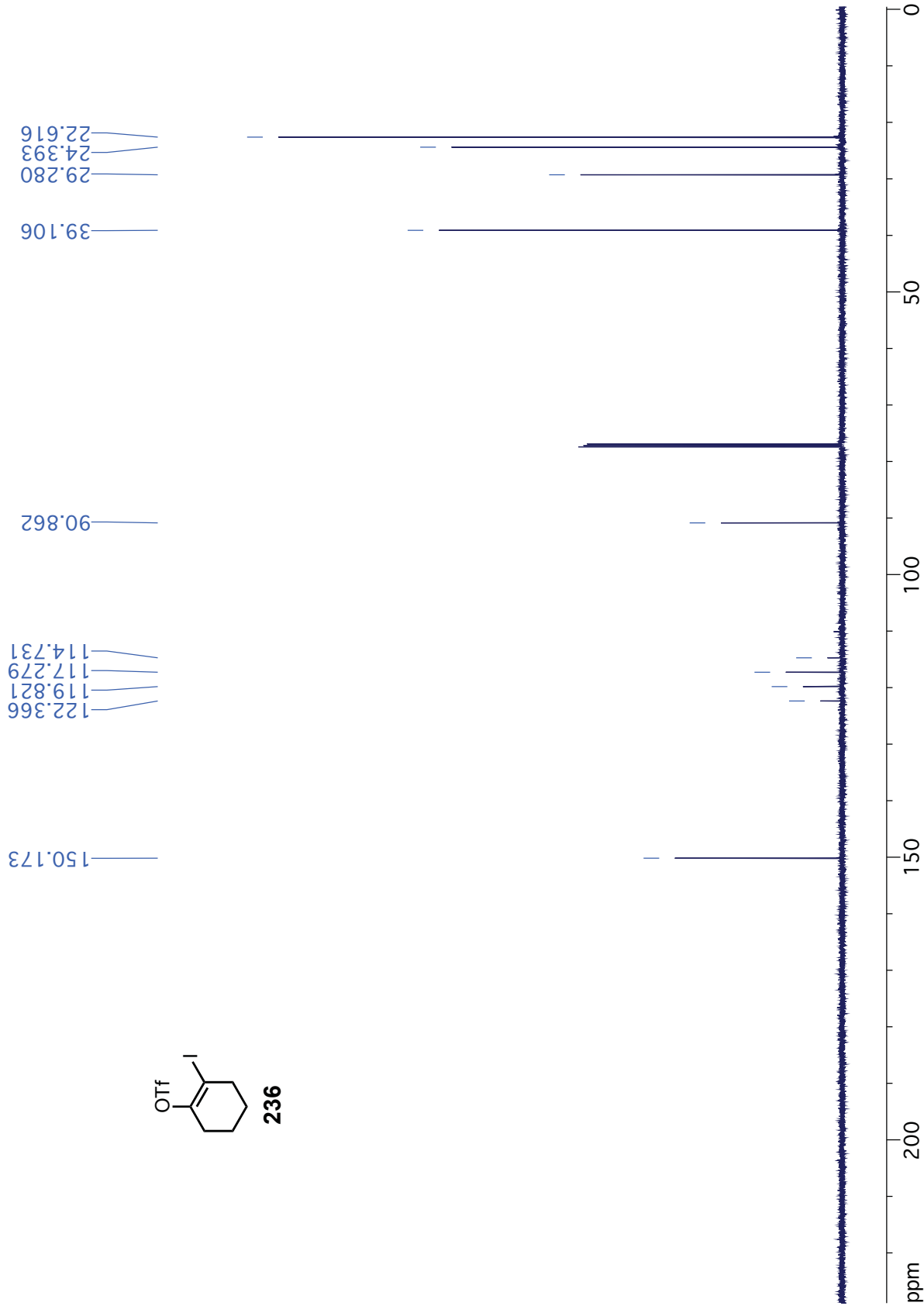

¹H NMR (CDCl₃, 500 MHz): 2-Chlorocyclohex-1-en-1-yl trifluoromethanesulfonate (238)

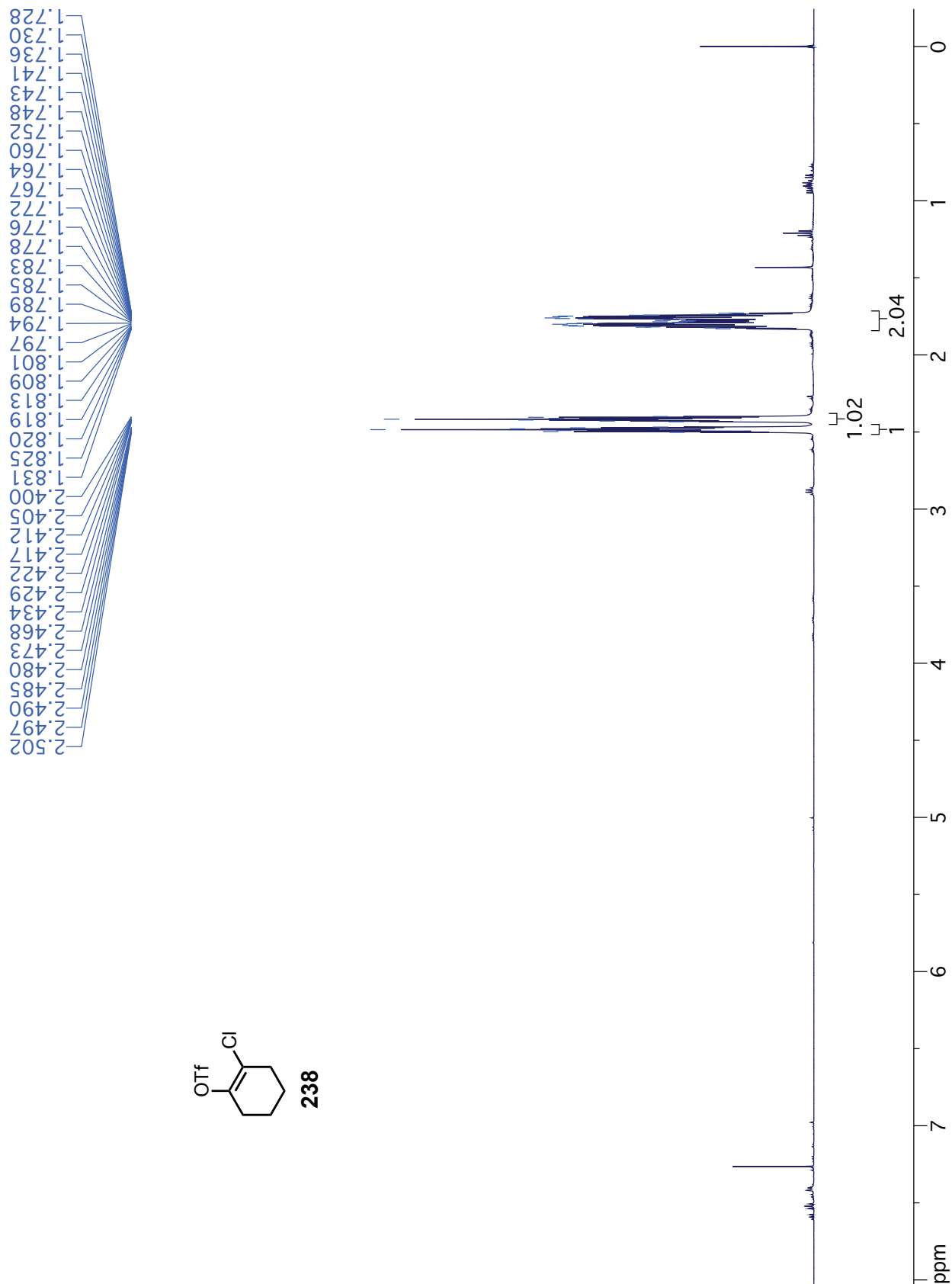
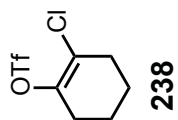

¹³C NMR (CDCl₃, 126 MHz): 2-Chlorocyclohex-1-en-1-yl trifluoromethanesulfonate (238)

