

**Compact Living:  
Rethinking Calgary's Laneways**

by

Matthew Kennedy

Submitted in partial fulfillment of the requirements  
for the degree of Master of Architecture

at

Dalhousie University  
Halifax, Nova Scotia  
July 2012

© Copyright by Matthew Kennedy, 2012

**DALHOUSIE UNIVERSITY**  
**SCHOOL OF ARCHITECTURE**

The undersigned hereby certify that they have read and recommend to the Faculty of Graduate Studies for acceptance a thesis entitled “Compact Living: Rethinking Calgary’s Laneways” by Matthew Kennedy in partial fulfillment of the requirements for the degree of Master of Architecture.

Dated: July 10, 2012

Supervisor: \_\_\_\_\_

Reader: \_\_\_\_\_

Reader: \_\_\_\_\_

## DALHOUSIE UNIVERSITY

Date: July 10, 2012

AUTHOR: Matthew Kennedy

TITLE: Compact Living: Rethinking Calgary's Laneways

DEPARTMENT OR SCHOOL: School of Architecture

DEGREE: MArch                      CONVOCATION: May                      YEAR: 2013

Permission is herewith granted to Dalhousie University to circulate and to have copied for non-commercial purposes, at its discretion, the above title upon the request of individuals or institutions. I understand that my thesis will be electronically available to the public.

The author reserves other publication rights, and neither the thesis nor extensive extracts from it may be printed or otherwise reproduced without the author's written permission.

The author attests that permission has been obtained for the use of any copyrighted material appearing in the thesis (other than brief excerpts requiring only proper acknowledgement

---

Signature of Author

To my family,  
Supportive and encouraging.

# CONTENTS

Abstract.....	vi
Acknowledgements.....	vii
Chapter 1: Introduction .....	1
Chapter 2: Case Studies .....	5
Compact Japan.....	5
Latitude 35° 1'23.50"N, Longitude 135°47'36.69"E.....	8
Housing in Mazzorbo.....	12
Morphology.....	16
Chapter 3: City Context .....	19
Neighbourhood Typologies.....	22
Demographic.....	27
Site .....	29
Neighbourhood Comparison .....	31
Program.....	33
What are Their Uses?.....	33
What Can a Garage Be?.....	39
Chapter 4: Design .....	40
Incremental Change .....	40
Community and Landscape.....	45
Settlement Pattern .....	47
Dwelling Pattern .....	49
Community Scales .....	57
Chapter 5: Conclusion.....	64
Appendix A: Feasibility Study.....	65
Appendix B: Programmed Detail.....	67
Appendix C: Works.....	70
References.....	71

# ABSTRACT

Through architectural design, this investigation explores a strategy for defining the back alley as a new place of community and dwelling. The study considers ideas to design living spaces that offer amenities in a compact form as well as the creation of meaningful public and private spaces within the context of existing Calgary, Alberta, Canada neighborhoods. This thesis examines and evaluates ideas for the adaptation of patterns of existing communities to allow an increase in density to accommodate a diverse scope of families, life styles, income quintiles and utilization. The focus of the study is on small units of incremental change at a scale which can be undertaken by the individual homeowner or contractor. This study believes that it is in this spectrum that some of the most powerful and effective changes can be made in the urban fabric.

# ACKNOWLEDGEMENTS

I would like to first thank my Mom, Dad, Norbert and sisters for their love and support and for a lifetime of showing me that success is a direct result of hard work. I am especially thankful to my Mom for her whole hearted encouragement, optimism and... late night proof reading.

During my education I have been fortunate to have been influenced by a number of outstanding professors. I would like to thank my supervisor Roly Hudson and advisor Robert Collins for their insightful ideas, motivating critiques and good humor throughout the process. Thank you to Lee Schuette for always going above and beyond the call of duty, Emanuel Jannasch for his patience and attention to detail, Ted Cavanagh for giving his students great opportunities and to Grant Wanzel, a role model for every student, for his passion for humanities.

Both directly and indirectly my friends have played a key role in my education. Thanks to Dan and Pete for their constant exchange of ideas, stories and laughs over the years. Thank you to Andrew for his endless amount of positivity and energy and of course Mark and Clayton who without them, my projects would not be as complete. I look forward to the endeavors that together we will face in the future.

To Maggie and Lourdes, last, but never least, thank you for your smiles and good cheer that you shared daily with every student.

# CHAPTER 1: INTRODUCTION



City of Calgary: Image taken from Rosedale Community

The whole is greater than the sum of its parts.

-Aristotle (Ross 1924, 182)

Carrol has suggested that the act of making a great city involves the accumulation of years of planning, designing and building in a piecemeal fashion; not developing everything at once. (Carrol 2010, 10) Further, Jacobs argues that the building up of communities with a combination of new and old buildings, along with changes in zoning purposes, gives a neighborhood a richness that provides social, economic, and environmental diversity that creates a vibrant place in which to live (Jacobs 1993, 197). This study insists on developing a diverse, more urban, architecture for Calgary's inner suburbs.

Can a compact building typology be applied to existing suburban residential communities as a viable solution to increasing the population density, providing affordable housing, and accommodating an influx of diverse new residents and uses, while responding to the current needs of the current residents?



As proposed by Lewis, housing is both an architectural and urban issue with the quality of urban life in cities depending largely on good design at both the neighborhood and building scale (Lewis 2005, 3). The result of sprawl in Calgary has been dramatic on a number of levels. The city's low-density footprint is an outcome of constant construction occurring at the fringes of the city. This form of development spreads the populace and growth from a central urban setting outward to rural areas.

Putman makes the observation that as a symptom of urban sprawl, the commuter lifestyle is associated with social isolation. It is a fact that more time spent in the car commuting means more time alone and less time with family, friends, civic engagements and so on (Putman 2000, 495). Additionally, Byers indicates that suburban development has also marginalized pedestrian traffic, public transportation, and spaces of spontaneous civic interaction, creating communities where neighbors do not know each other (Byers 2003, 24).

Calgary neighborhoods need to adapt to meet the needs of evolving conditions, both social and economic. The contemporary family has changed since the baby boomers and the original development of suburbia. Smaller, yet efficient, homes may be preferred by families having fewer children and the increasing number of elderly. The baby boomers on a fixed income with no children living at home may wish to create rental property to supplement their income. The working mother with

less time to tend to a large house, drive the children to school and activities or grocery shop may prefer a smaller dwelling closer to local amenities and public transportation.

As a result of Calgary's economic boom in 2008, rental rates increased 40 percent when compared to just three years prior (CMHC 2011). Also, the number of apartments for rent in the city was dwindling because of an aggressive condo conversion trend (Ghitter 2011). In appendix A, a feasibility study was conducted with two goals in mind: to determine the viability of Laneway Homes (an affordable housing solution for the 72,000 Calgarians who spend more than 30% of their income on housing), and to establish the potential for the homeowner to offset their cost of living with additional income generated through a tenant. The project also investigated the sustainability and cost benefit of compact living with potential applications to prefabrication. The results of the study were mixed. It was discovered that although the laneway dwelling is a viable solution for increasing the housing pool, not enough income could be generated by the lower two income quintiles initially to offset the homeowner's monthly mortgage. The rental rate could only accommodate as low as the third lowest income quintile. See Appendix A for further results of the feasibility study.

The intention of this thesis is to examine and evaluate ideas for the adaptation of patterns of existing communities to allow an increase in density to accommodate a diverse scope of families, life styles, income quintiles and utilization. The focus of the study is on the small units of incremental change at a scale which can be undertaken by the free market: individual homeowner or contractor. This study sees that it is within this spectrum that some of the most powerful and effective changes can be made in the urban fabric.

The introduction of laneway dwellings into the fabric of Calgary's districts could be the small incremental change needed to repair and renew the unity of the neighborhood as well as add to its formal and social intricacies while increasing its density. This includes developing new ideas for building on existing sites in existing communities taking into consideration community space, division between public and private realms, and solar orientation. It also explores ideas to create various levels of built-in organization that enables the user to refine the space to suit their needs while allowing for a multi-programmable space that could accommodate, for example, a small businesses or an artist's studio .

This study explores the integration of digital fabrication with architectural details as a means of making site specific building components that are of high quality in design and craft (see Appendix B).

## CHAPTER 2: CASE STUDIES

The following case studies were selected because of their built scale, relationship between public and private spaces and compact form. This study found fascinating the dense urban environment of Japanese cities. The cities are an accumulation of small changes that over time reveal communities that are full of intricacies and vibrancies of civic life. The housing project in Mazzorbo was of particular interest. It was cited as a new development in the midst of an already well defined city context as well as for its formal details and varying scales between inside and outside and street and courtyard. Both projects support a compact dynamic community which contains elements that the study finds inspiring.

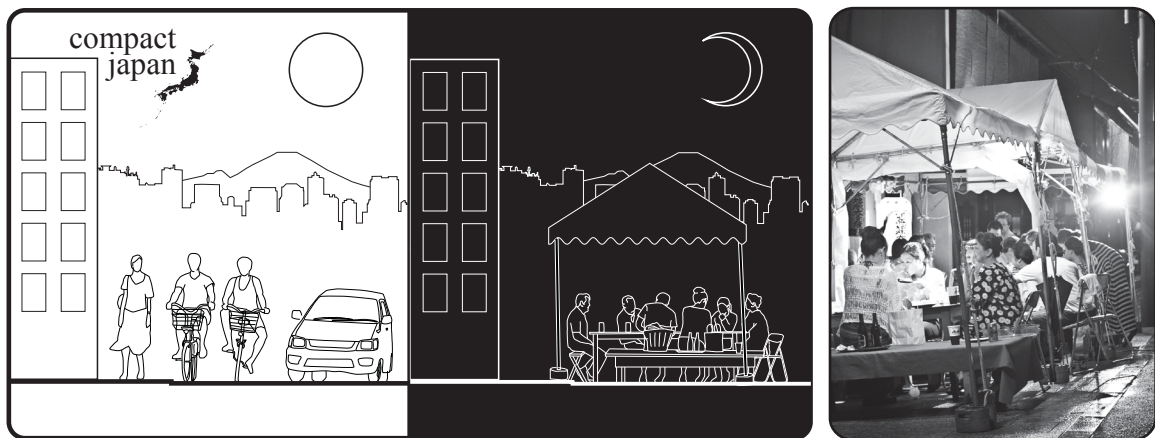
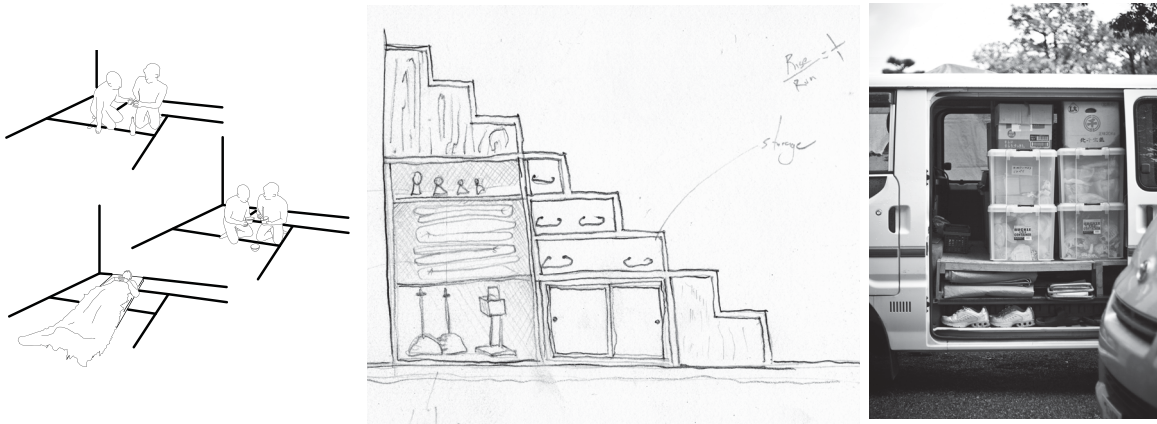

Diagram and photo of candid family gathering in Kyoto where the family took over the street for an evening celebration. During the day the street functions as an avenue for vehicles, bicyclists and pedestrians.

### Compact Japan

Pre-thesis research for this study was funded by the Rosetti Scholarship. This research involved travelling to Japan to observe and record compact urban settings in

Japanese physical and social environments. It considered the dynamism of the people and architectural designs in adapting and transforming to create community spaces, as well as examined the relationship between public and private spaces.



Built layers of organization are integrated into many components of Japan's built culture, which allows for an area to be multi-programmable.

While in Japan, the study documented candid events of locals gathering, socializing, and celebrating. This included day-to-day interactions, informal family gatherings and large public festivals. Japanese cities have an incredible ability to flex and adapt. Their spaces are reprogrammed to activate life throughout the day and into the night. Major city thoroughfares are converted into picnic grounds for civic celebrations. Tents are erected in streets for family reunions. A single space in a home has multiple programs that can adapt; for example, from a dining area, to a lounge, to a sleeping quarter. The flexibility in space is possible due to an infrastructure of organization built into their homes. Compartments and storage exist in almost all allowable locations. As

most spaces are compact, there is extra emphasis on the art of making, with an inherent sensibility towards the natural environment, craft, and design. Many of the urban observations of Japanese neighborhoods parallel Jane Jacobs's observations of vibrant successful neighborhoods in the United States where she writes:

The district, and indeed as many of its internal parts as possible, must serve more than one primary function; preferably more than two. These must insure the presence of people who go outdoors on different schedules and are in the place for different purposes, but who are able to use many facilities in common. (Jacobs 1993, 197)

Although Japanese cities are dense metropolises, their citizens unassumingly recognize their place in nature and cultivate integrated sources of food. The study witnessed plateaus of rice fields in the dense suburbs of Tokyo, as well as the potted plants that overflow into the narrow streets of Kyoto. This connection to nature and growing in extreme urban locations adds a sensibility to its inhabitants where there is a direct visible relationship between producing and consuming.



Sketches of street level in Kyoto.



Map of neighbourhood in Kyoto, located  $35^{\circ} 1'23.50''\text{N}$ ,  $135^{\circ}47'36.69''\text{E}$

### **Latitude $35^{\circ} 1'23.50''\text{N}$ , Longitude $135^{\circ}47'36.69''\text{E}$**

The whole of a contemporary Japanese city is made up of a series of accidents in accordance with inevitable changes to the overall urban plan. (Kaijima 2006, 11)

The tight narrow streets of the dense urban neighborhoods of Kyoto, is where the majority of time was spent as it offered a similar typology to a laneway. The building facades on the streets were dynamic as they formed a wedge shape or pocket around the entryways. These areas were the life of the street. It was here that plants grew, bikes were parked, and where people would seek shade and relax. The fragmented building typology offered a roughness, where the scale between the buildings and the street forced vehicles and people to move more slowly. These folding fronts increase the surface area

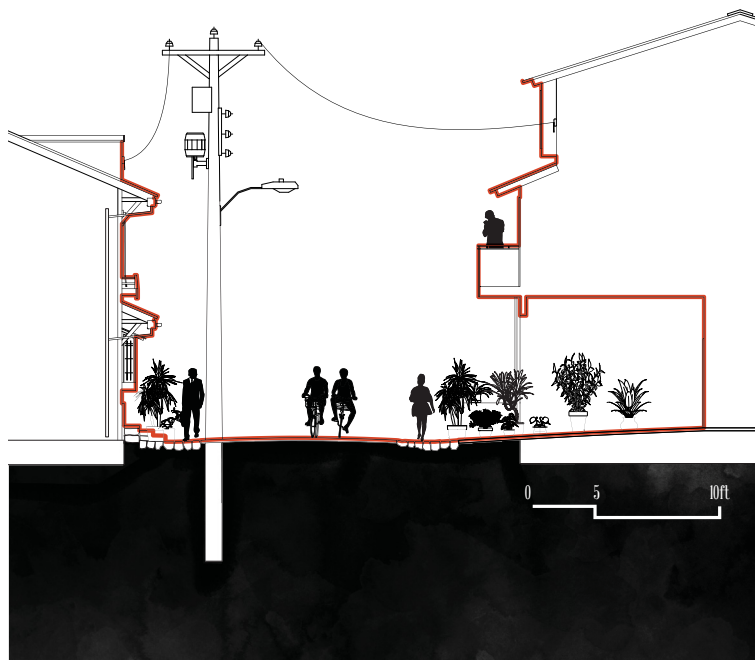

Section Through Machiya Neighbourhood in Kyoto illustrating the intimate scale of the street and pockets for life to happen.

at ground level and enhance the opportunities to form relationships between other buildings and the street with the result of the occurrence of more spontaneous engagements. The above is a street plan of a typical neighborhood in Kyoto. There is a mixture of new and old homes as well as commercial and residential. The urban form appears to be quite chaotic but dates back to 200 years to the Edo era. The main streets are lined with larger homes with storefronts called *Machiya Quarters* (Shelton 1999, 76). In urban centers in Japan there is an apparent attitude of planning that involves ‘filling all the gaps’. These ‘fill’ buildings are tested in their sense and efficiency in working out how to gain maximum utility from these void spaces (Kaijima 2006, 24). In Kyoto’s history, these ‘fill’ building are called *Nagaya*. The *Nagaya* are small houses located behind the *Machiya*.



They are connected to the main street with a small alley that is three to six feet wide. In the past, this alley was considered a shared space with common bathing and washroom facilities (Shelton 1999, 82).

The *Machiya* normally stand independently from each other but side-by-side. The land use is quite intensive. They sit on rectangular plots with frontages three to four times narrower than their depth. This type of housing was synonymous with merchants. The front of the ground floor is typically a shop with the shop house at the back and upstairs (Shelton 1999, 77). Despite being located in a dense urban environment, the *Machiya* offers its inhabitants a sense of isolation and privacy. Sight lines are quite restrictive from the shop entrance to a small garden in behind. Vistas of the wider city are rare in these types of neighborhoods; one does not have the opportunity to view where they are in the context of their city (Shelton 1999, 77).

The neighborhoods with the modest *Machiya* typology have an interesting contrast between day and night. During the day the storefronts are open, covered with signs and lanterns and the streets feel mysterious and adventurous to passersby. The stores spill out onto the street, blurring the boundary between building and city, interior and exterior, private and public. These streets are only 15 or 20 feet wide, offering an intimate scale between users and buildings. Walking around these same streets at night had a different feeling. Most of the storefronts were closed, hidden behind bamboo and paper screens, and the



Rooftops and streets of Kyoto.

streets felt calm and quiet with just a few people about.

This would have been the lasting impression of nightlife on the street, except that one evening, while walking the usual route back to the hostel, we came across what looked like a family event. The inhabitants of the neighboring building had annexed the street for the evening, setting up tents and barbecues. This was fascinating to see how the street was so easily adapted to facilitate such an event.

The complexity and intricacies of this Kyoto street is something that has developed over a number of years with increments of small interwoven interventions. Even in this dense urban environment their vernacular homes offer them a sense of privacy and a connection to nature as well as giving the inhabitants the opportunity to adapt the architecture around them to facilitate their needs. From the above image, Kyoto is a city of rooftops, as the downtown rooftops are covered with restaurants, gardens and shrines. In the *Machiya* neighborhoods,

this free space to vistas, sky, and sunlight are relatively unexplored. Living in a compact environment means finding new uses as well as dual uses for existing spaces. This study feels that the rooftops of a laneways dwelling can be programmable space which acts as an extension of house and the backyard.

This study believes that laneway housing in Calgary can learn from the streets of Kyoto. Back alleys can be transformed to be part of the small changes that can, over time, convert neighborhoods into communities with exciting pedestrian streets, relaxed car dependency, and offer an abundance of local small businesses.



The island of Mazzorbo (left) connected with a pedestrian bridge to the Island of Burano.  
(Bing Maps 2012)

## Housing in Mazzorbo

The Mazzorbo project was designed by architect Giancarlo De Carlo in 1980. De Carlo was one of the founders of Team 10. He was part of the movement that challenged the rationalism of Modernism and argued for

more user collaboration within the design process, reading of context, history, and territory as well as social issues such as reuse of historic sites and buildings. The project is located on the farming island of Mazzorbo; the island is connected by a pedestrian walking bridge to the well-known fishing island of Burano (adjacent to Venice, Italy).

The development was initially planned to be Council housing and to accommodate eighty single-family dwellings. The homes were designed for families living in existing dilapidated Council housing in Mazzorbo and inhabitants of Burano, who also lived in poor conditions. The entire development was to be built in three stages; however, after the first stage was completed the project ended. As seen in the area map above, the first phase of the dwellings is located directly across the pedestrian bridge from Burano. The type of house shifts from a denser typology seen in Burano to the smaller scale seen in Mazzorbo as the scheme develops away from the bridge between the two islands (Veneta 1989, 28).

The first phase of the development was a thirty-six dwelling community. There are two pedestrian bridges that must be crossed to get to the community. The colorful houses can be seen from both bridges but they do not line up parallel to the central pedestrian axis of the community, but instead at an acute angle. This gives the community a layer of privacy from onlookers. As the resident journeys closer to their home, the central space slowly opens to them. The curved glass facade of a cafe is an indicator of

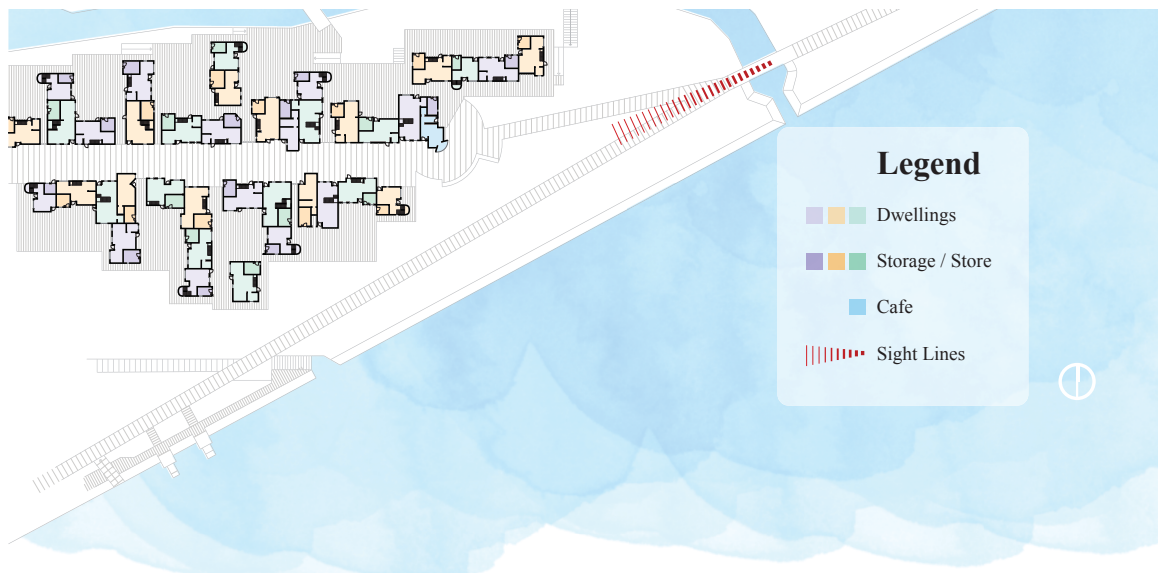

Ground floorplan of the first phase of development in Mazzorbo. Adapted information from Veneta, 1989.

the beginning of the community. After passing by the café, the resident is in the center of the pedestrian road that is bordered by a chain of housing on either side. The colorful housing facades push in and out, up and down, to delineate openings, staircases, and dwelling units from one another. The effect creates interesting housing fronts of varying shadow lines and pockets of space that can be filled with plants, bikes, or offer a shady place to sit. The chain of housing on either side of the street is also broken up by large covered walkways that penetrate perpendicularly through the housing block to small courtyards that are bordered by more dwellings on three sides. The fourth side of every courtyard is open to the canal to maintain the dweller's relationship to the water. These various scales of community are illustrated in the diagram in the Morphology section: community constructed of many parts, community around street, and community around courtyard.



Left: Pedestrian walkway in Mazzorbo (Veneta 1989, 55). Right, Canal in Burano

The entire development is built on a one meter high plinth above sea level. This plinth achieves two important tasks: firstly, it protects from flooding caused by high tides; secondly, it allows for a minimal threshold between indoor and outdoor spaces. De Carlo, through his observations of studying the Buranese in their day-to-day lives, recognized them to be very socially oriented. Their gatherings changed from outside to inside frequently, according to the time of day, climate, and the nature of the activity. In order to avoid any obstacles, both physically and psychologically, from interrupting the continuity between the inside and the outside of their home, the threshold of the front door are never higher than an inch (Veneta 1989, 59). The section illustrates the relationship between the street and the most public space of the house: the kitchen area. The minimal threshold between inside and outside makes it possible for informal interactions between the island dwellers as well as set a small stage for informing neighbors what is happening inside of the home.

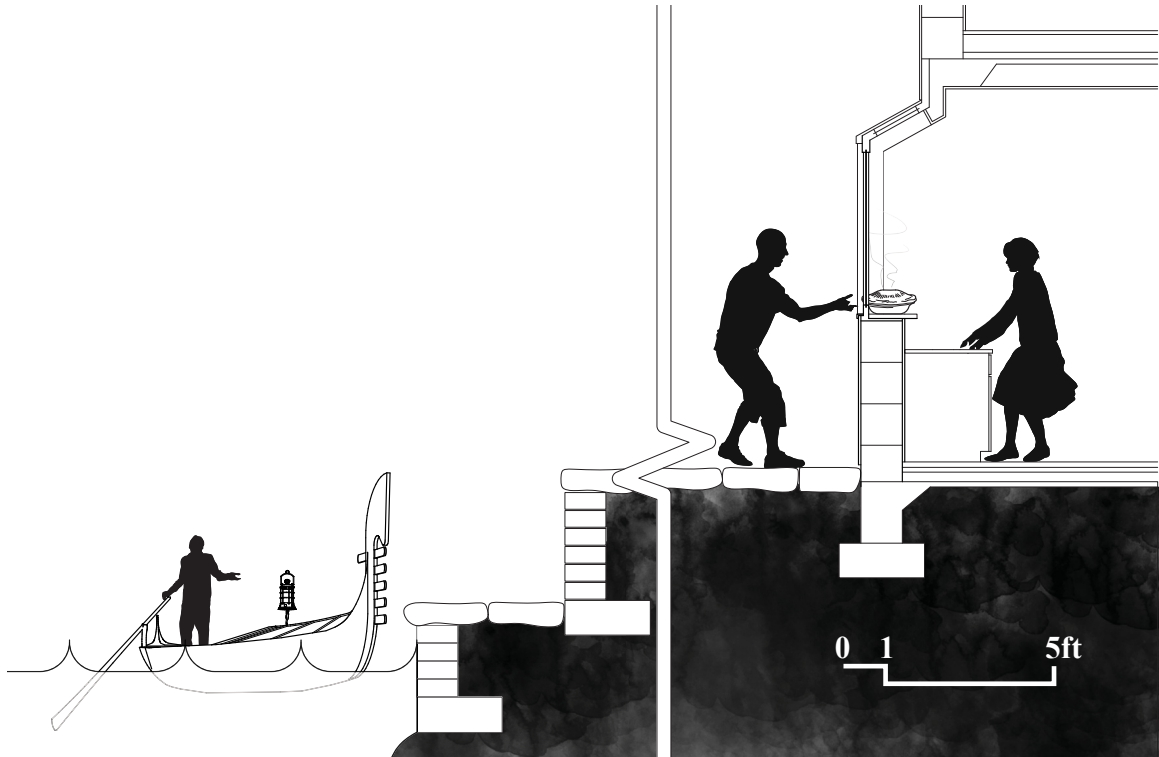

Cross Section of kitchen window detail and threshold between interior and exterior space.

### **Morphology**

The thirty-six homes are composed of a combination of five prototype single-family dwellings that range from two to three stories tall. Each floor plan has a number of variations that allows the choreography of building components, which enables the households to adapt to different site conditions. De Carlo observed that the lower income Buranese who would inhabit the dwelling, usually had a large collection of objects and tools, most of which would not be desirable to store in a home (Veneta 1989, 61). As a result, each house has a room of about 7ft x 10ft located on the ground floor with a separate entrance. This space can be used as a storage area or has the potential to be a small storefront.

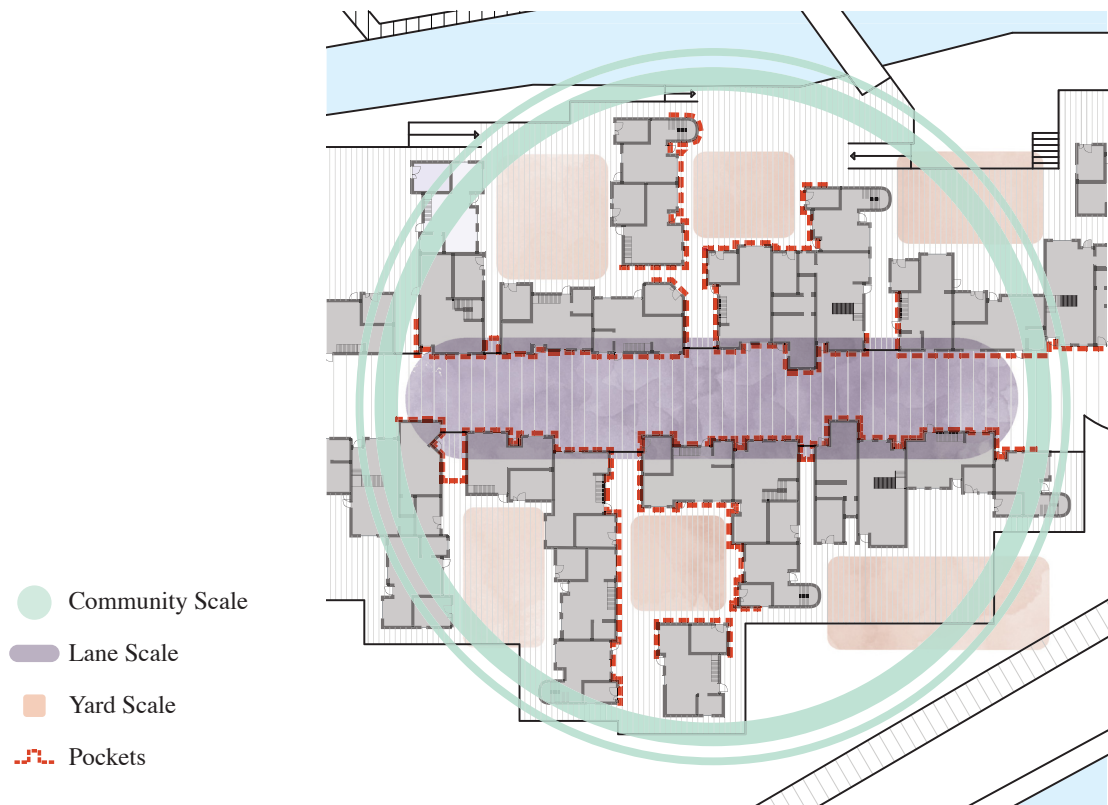

Map of various gathering spaces in Mazzorbo. Adapted information from Veneta, 1989.

The De Carlo housing project on Mazzorbo was selected as a case study for its formal details, historic context and sensitivity to site and culture. The element of this project that is most interesting is the relationships between indoor and outdoor spaces and how this can be used as a tool to create stronger communities. Housing has a very delicate relationship between public and private spaces. De Carlo was able to formalize a solution where the most public realm of the interior of the house, the kitchen, is adjacent to the most public realm of the exterior of the house creating an opportunity to foster community.

Although the housing blocks are broken up by pathways and varying facades, this study finds the clean modernist form of the development, combined with the



lack of vegetation, to be stark. Other than potted plants next to doorways there is little room for the dweller to make the space their own. Possibly because of the architectural significance of the project, rules may be enforced that prevent the occupants from draping the exterior of their homes with the eclectic clutter and clothes lines as seen in the houses in Burano.

Mazzorbo and Kyoto sit at two ends of the spectrum, ranging from a formal planned community to an informal piecemeal city. Calgary's laneways fit somewhere in the middle of the scope. The plan for the development of back alley dwellings is intended to be incremental and over a period of time. Elements shared by both projects that inspire this study are the intimate scale of the individual buildings and their relationship formed with the street. As one building is built next to another, the pockets and wedges of the individual dwellings create a rough edge for the dwellers to program and inhabit. This allows activities of the dweller to spill out on to the street creating an informal public space.



Image of the Housing project in Mazzorbo from the canal. (Veneta 1989, 62)

## CHAPTER 3: CITY CONTEXT

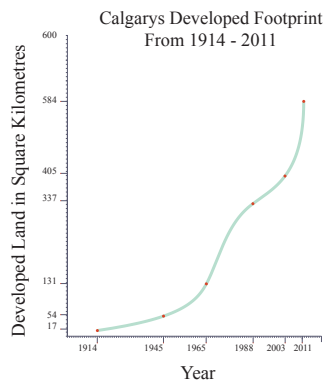

Calgary 1914

Calgary 1945

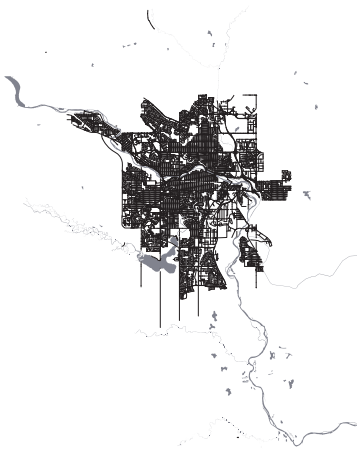

Calgary 1965

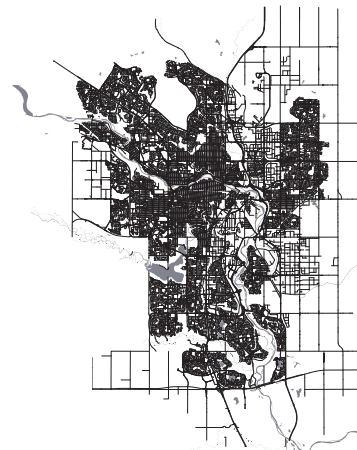

Calgary 1988



Calgary 2003



Incremental maps of Calgary's road networks from 1914-2011. Adapted data from Sandalack 2006.

Calgary is a young city that has evolved from its pioneer roots to modernity in little over a hundred years. In that time, the population has grown from approximately 4000 to more than one million (Sandalack 2006, 1). The city's framework was initially developed with a colonial

grid network system, where the grid was draped over the landscape disregarding geographical features to create the road networks. Houses were built on long narrow lots with very little accommodation for an automobile. Parking was achieved by the use of rear lanes, or with driveways from the street to the rear garages. Shopping at this time occurred in small corner stores on arterial streets which could be easily reached on foot (Diamond 1981, 1).

Most of the growth in the 1960's and later in Calgary has taken the form of single-use and low density neighbourhoods and it is now smothered by its suburbs (Sandalack 2006, 77). Land zoning in this era is largely contributed to the English urban theorist, Ebenezer Howard. Howard argued for separation of uses calling for a separate place for living, working, making, and civic engagements (Nicolaidis 2003, 165). Calgary prescribed to Howards 'Garden City' ideologies to the extent that they commissioned fellow English urban planner Thomas Mawson to design a master plan for the city. This approach to planning led to an oversimplification of zoning and desire to regulate land use. A result of functional land use zoning was a greater dissociation between places of living, places of working, and places of shopping (Sandalack 2006, 1).

Calgary's suburban form is primarily single use, low density and auto dependent with a series of disconnected curvilinear streets. The previous maps show the geographical footprint of Calgary and how it has

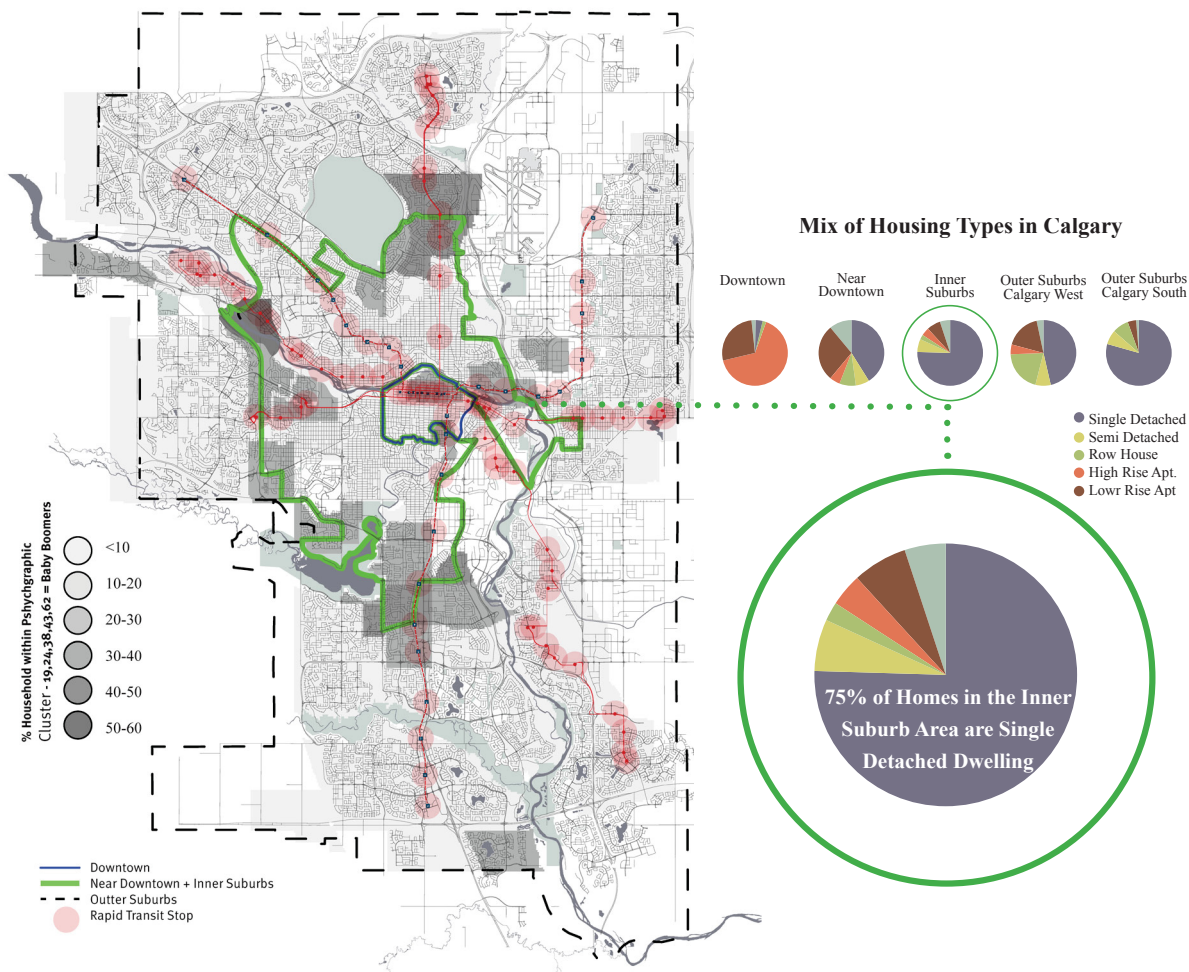

Area map shows the primary areas where the babyboomer profile lives in the city. The Pie Charts indicate mix of housing types in Calgary. Diagrams are made using adapted information from CMHC 2011.

grown over the years. This form of development has come with a price. The costs of services to provide the necessary infrastructure for new neighbourhoods are escalating while the tax base has stabilized or is decreasing. This is particularly true of transit services, which are both labour and fuel intensive, are increasingly necessary to the suburban resident and yet are uneconomical at low densities and in winding street patterns (Diamond 1981, 3).

## **Neighbourhood Typologies**

### **Near Downtown**

The near downtown area was originally developed by extending, or grafting, on to existing grid framework. The street was intended as a public space. Trees were planted along the streets in an effort to make these prairie neighborhoods more attractive in which to live. Most neighborhoods were single family and mixed use, with retail areas within easy walking distance or accessible by streetcar. Neighborhoods built during this phase are still the most walkable today, with a permeable grid with frequent connections providing a high degree of choice of paths (Sandalack 2006, 1).

### **Inner Suburb**

This low-density community was built in the late 1960's adjacent to the University of Calgary just after the university opened its doors. This area is exclusively single family homes that sit on large lots typically 15m x 30m in size. The University of Calgary's Student Union has been lobbying to amend the R1 zoning to allow for the Varsity community to be zoned for Secondary Suites as a response to the lack of student housing in the area.

### **Outer Suburb**

This is an example of a newly built starter home community in the outer suburb area. The single detached dwellings are typically two stories in height and sit on narrow lots.

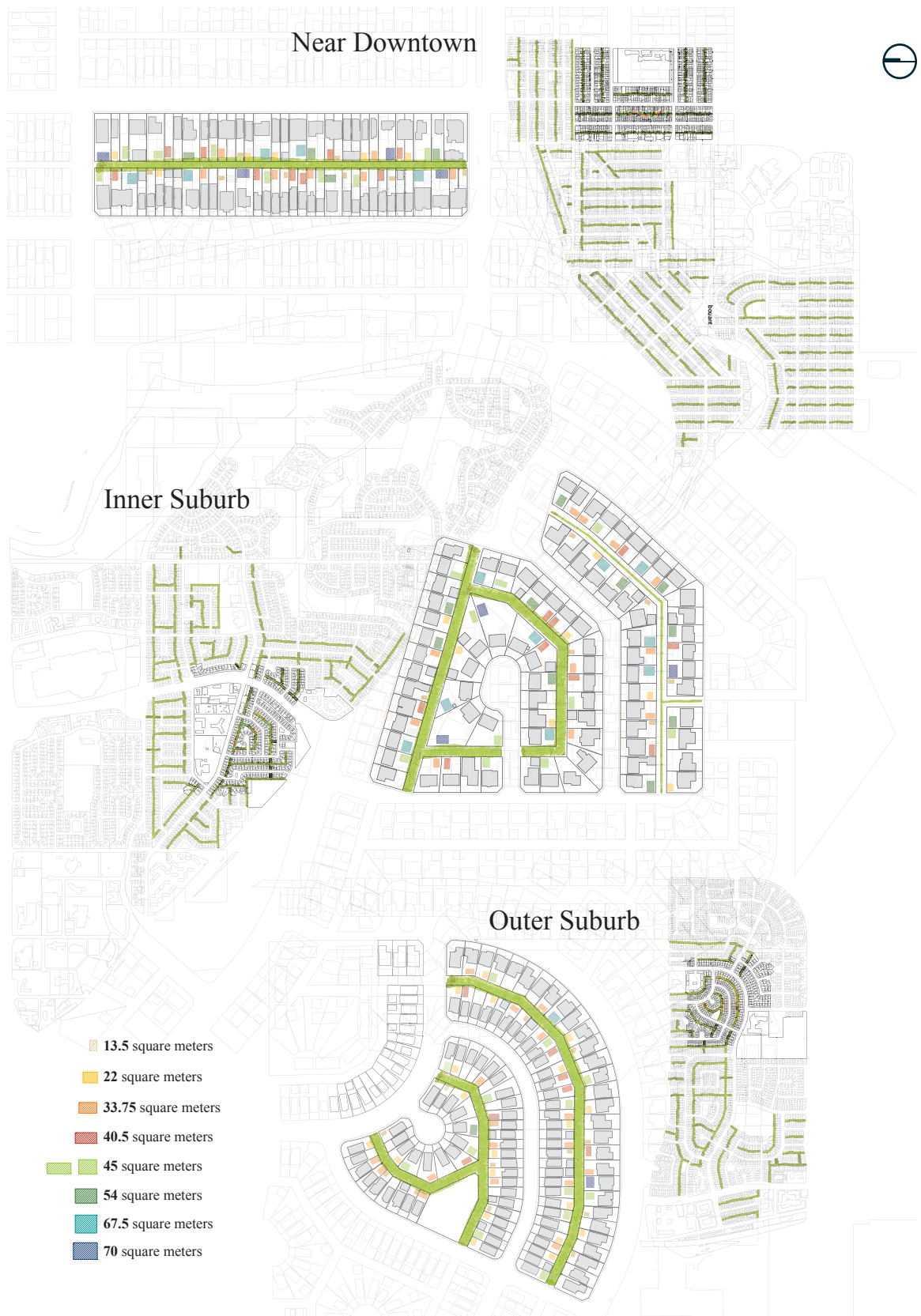

This diagram investigates various dwelling footprints and how they can be situated on various lots in different neighbourhood typologies in Calgary.

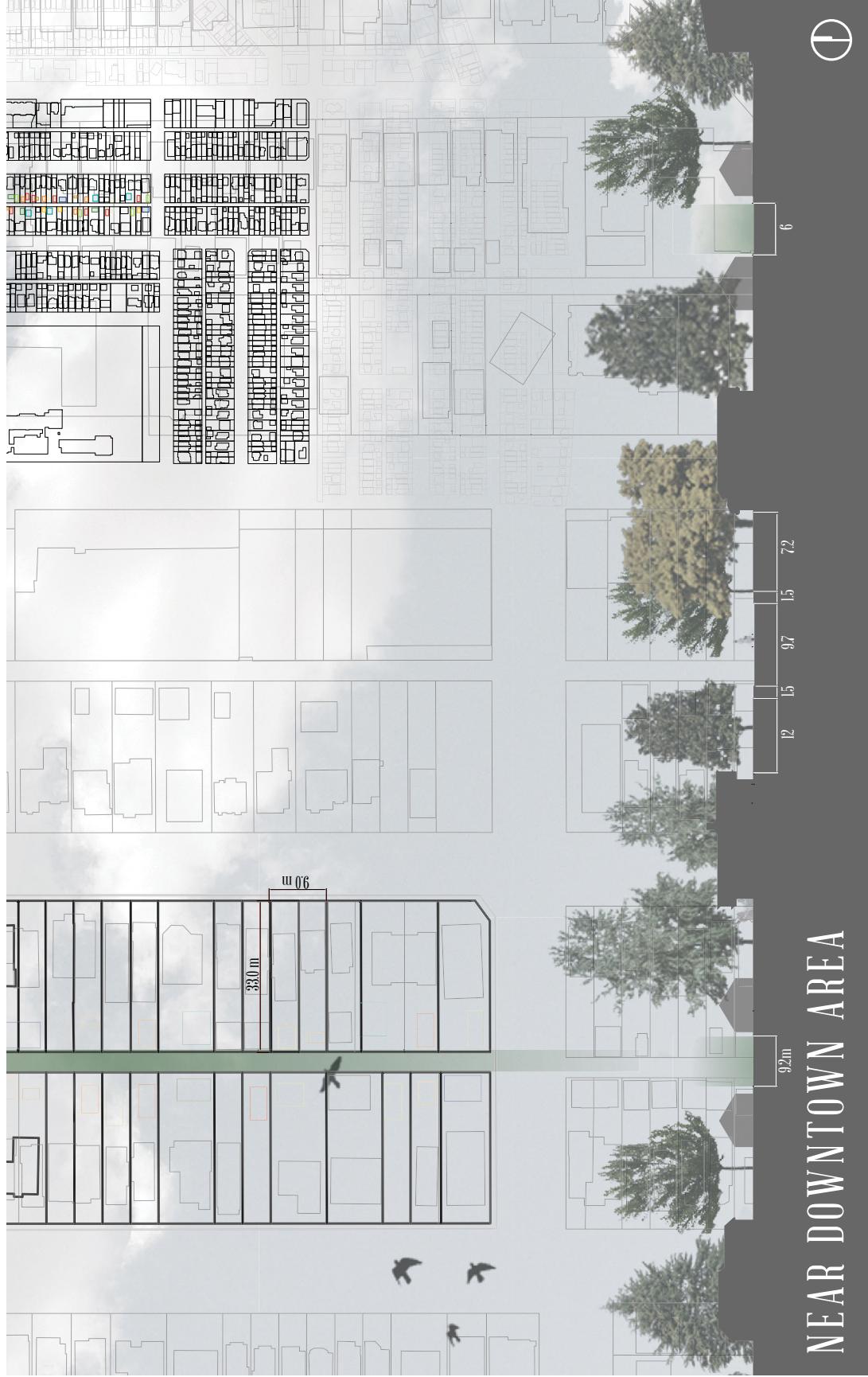

This is a section and plan of an existing neighbourhood block in the near downtown area of Calgary. The drawing shows existing dimensions of the community block.

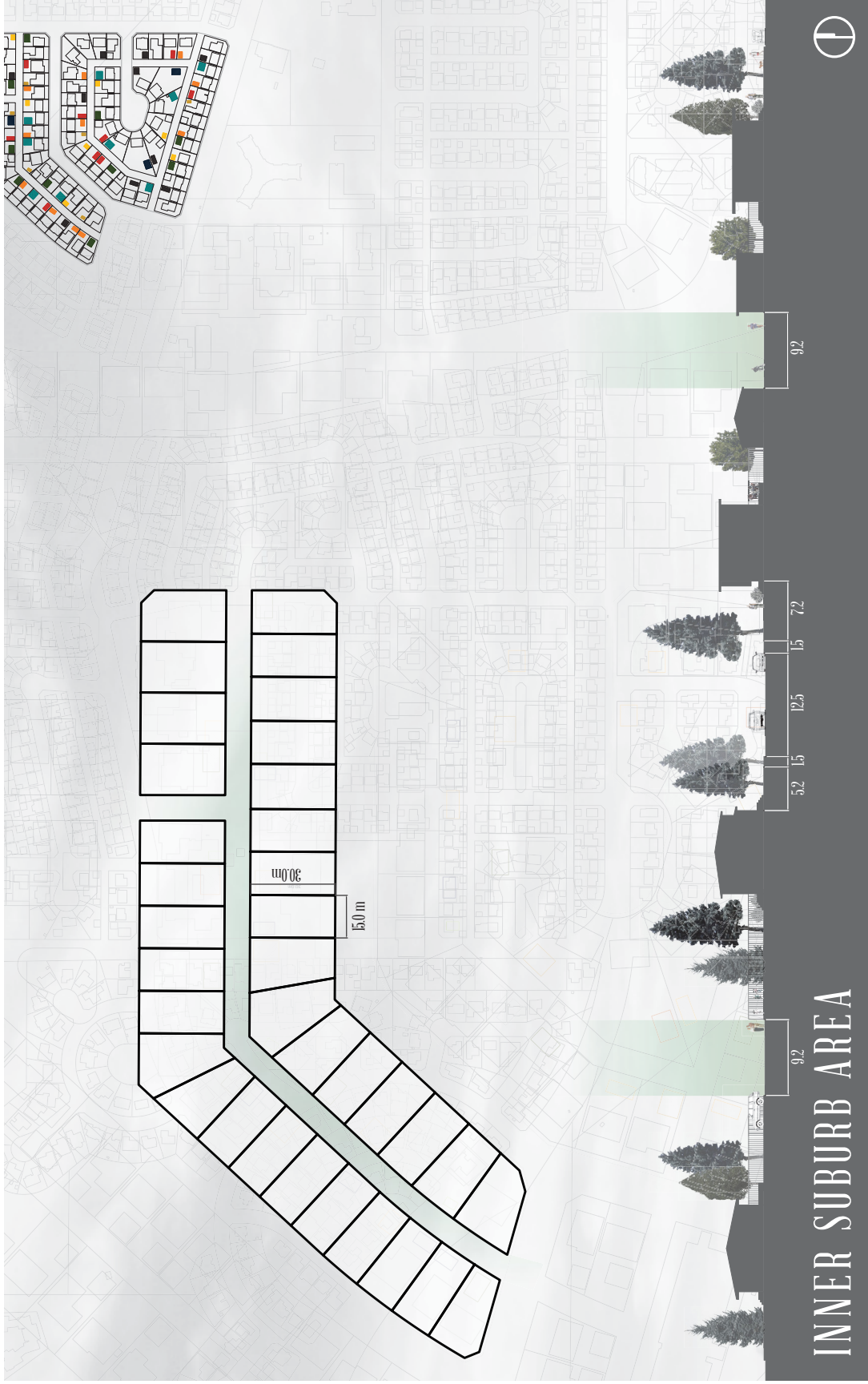

This is a section and plan of an existing neighbourhood block in the inner suburb area of Calgary. The drawing shows existing dimensions of the community block.



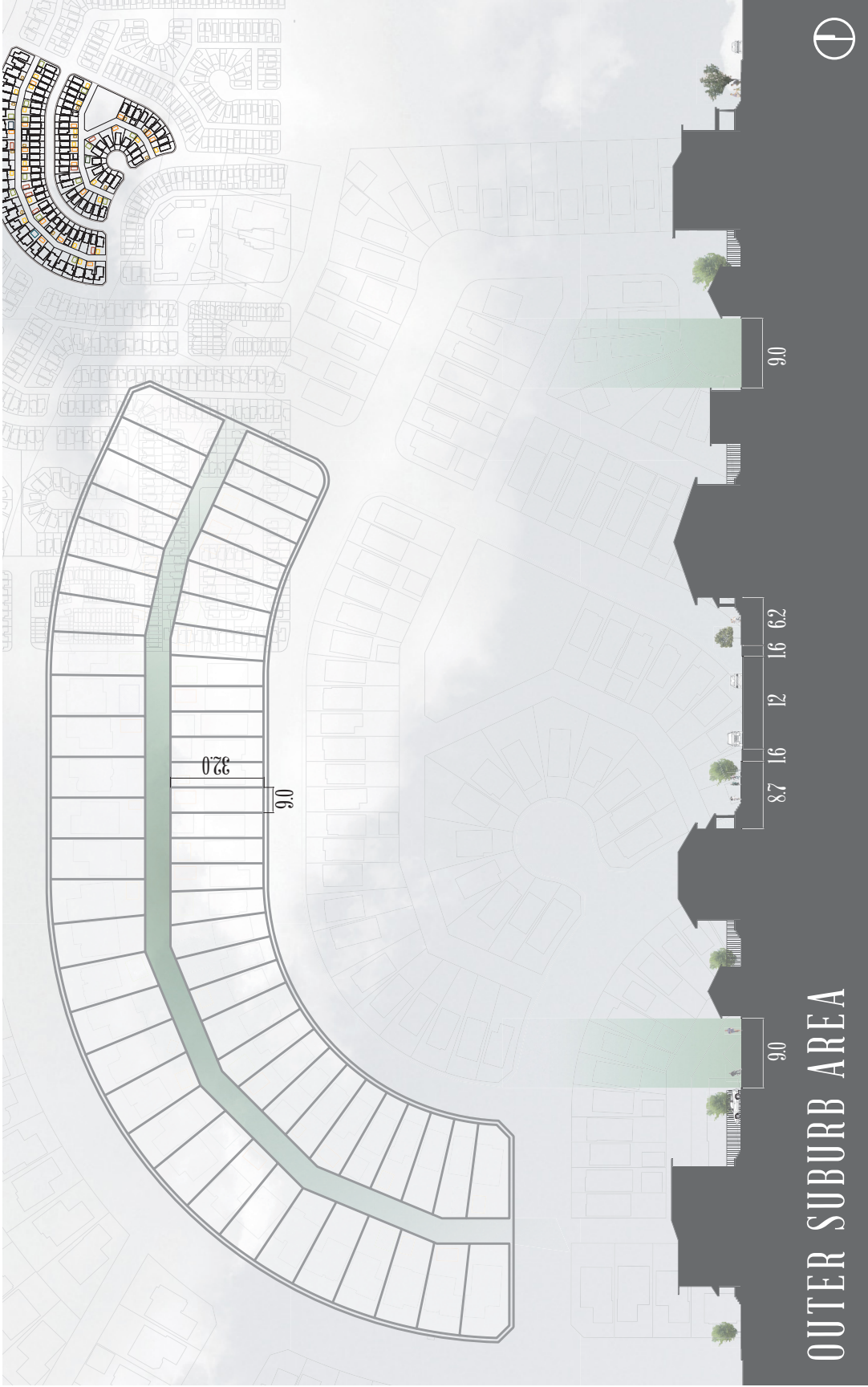

This is a section and plan of an existing neighbourhood block in the outer suburb area of Calgary. The drawing shows existing dimensions of the community block.

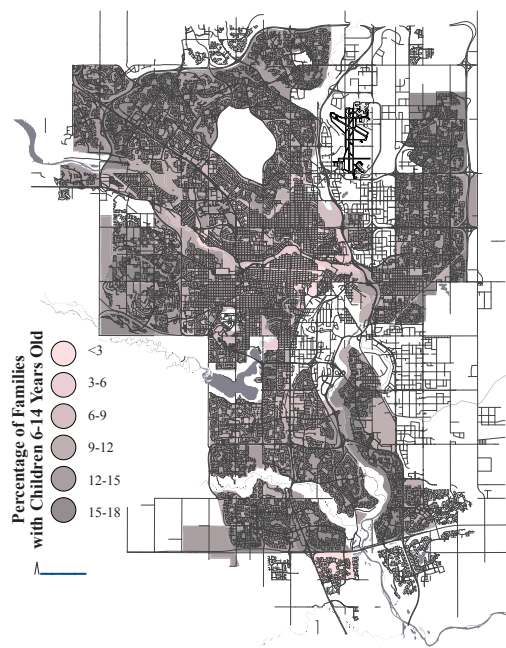
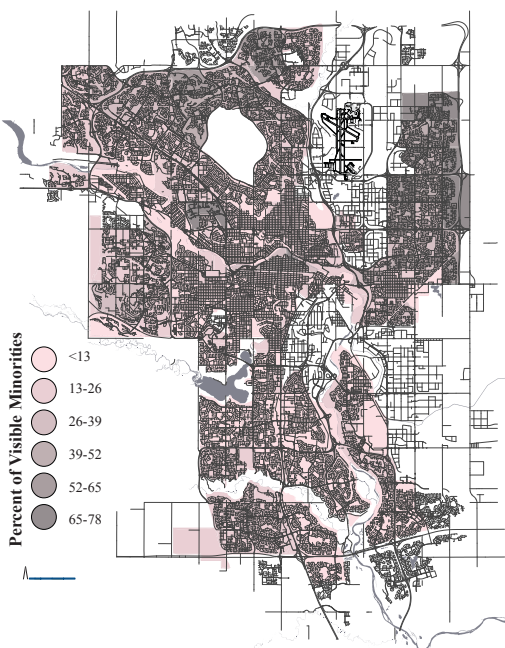
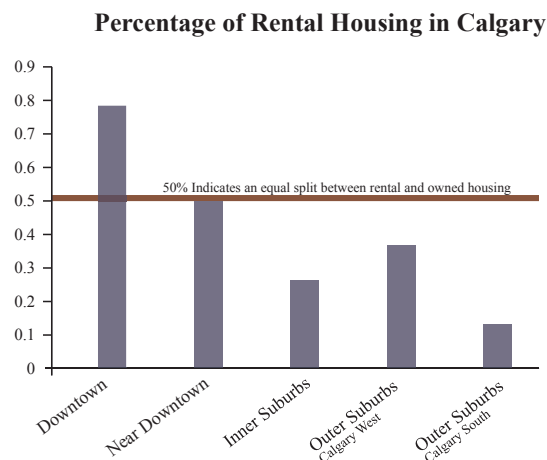
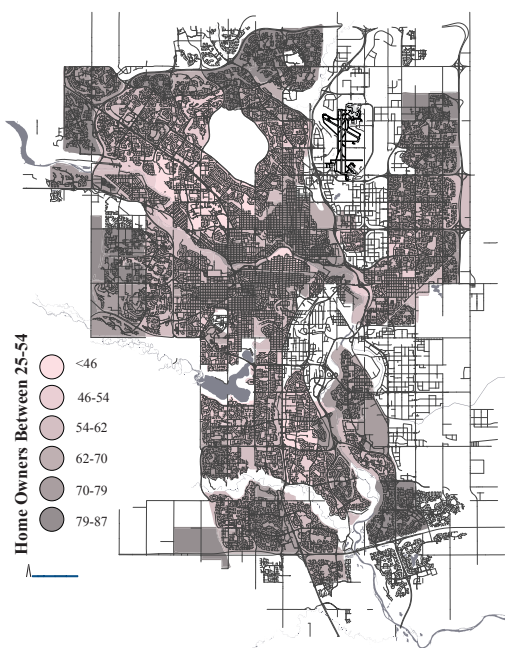

The Demographic Maps are made with adapted information from Mount Royal University Statistic Department. Percentage of rental housing in Calgary diagram is made with adapted information from CMHC, 2011.

## Demographic

The above maps are current demographic distributions across Calgary of visible minorities, homeowners between the ages of 25-54 years, and school aged children between 6 and 14 years.

From the evidence, Calgary neighborhoods are growing to be separated by age, income and ethnicity, creating bland and senseless places to live. The center maps illustrate where people between the ages of 25-54 own homes. The city core and inner suburb area is increasingly more expensive. People moving to the city, along with a generation of Calgarians who grew up in the city, cannot afford to buy in these areas and are forced to settle in the outer suburban area, with Calgarians chanting the all-too-popular mantra 'drive until you qualify'. As a result, affordable homes in the inner suburb areas, that would not require the daily dependence on a car for transportation, are increasingly difficult to find. The older neighborhoods are replete with an aging population and new families cannot afford to buy into these communities with the result of primary and secondary schools being shut down because there are not enough students to support the schools. The result is neighborhoods of monocultures. Communities are separated by age, income and ethnicity with little diversity. Jane Jacobs argues that communities need a heterogeneous collection of people as a means of problem solving and maintaining a dynamic neighborhood.

Dull, inert cities, it is true, do contain the seeds of their own destruction and little else. But lively, diverse, intense cities contain the seeds of their own regeneration, with energy enough to carry over for problems and needs outside themselves. (Jacobs 1993, 448)

In 2010, as a direct response to the high cost of living in Calgary, the City Council voted to change the zoning of all newly built communities to allow for built detached secondary suites on the site of single detached homes. The Mayor of Calgary, Naheed Nenshi, is leading a campaign to rezone Calgary to allow for secondary suites. A secondary suite can either be a small apartment or dwelling attached to the primary residence, or detached and located in the backyard, above a garage, or along the laneway on the property of the primary dwelling. Calgary community groups strongly support this proposal. If zoning is passed, this will make it possible for a homeowner in a single detached home to host a secondary dwelling on their property.

## **Site**

The areas that are best suited for laneway dwellings are inner suburb and near downtown communities. These areas are highly desirable places to live due to the close proximity to the downtown core of Calgary with easy access to Calgary's Rapid Transit Services. The inner suburb area also has the highest percentage of single detached dwellings; 75% of which would be eligible for

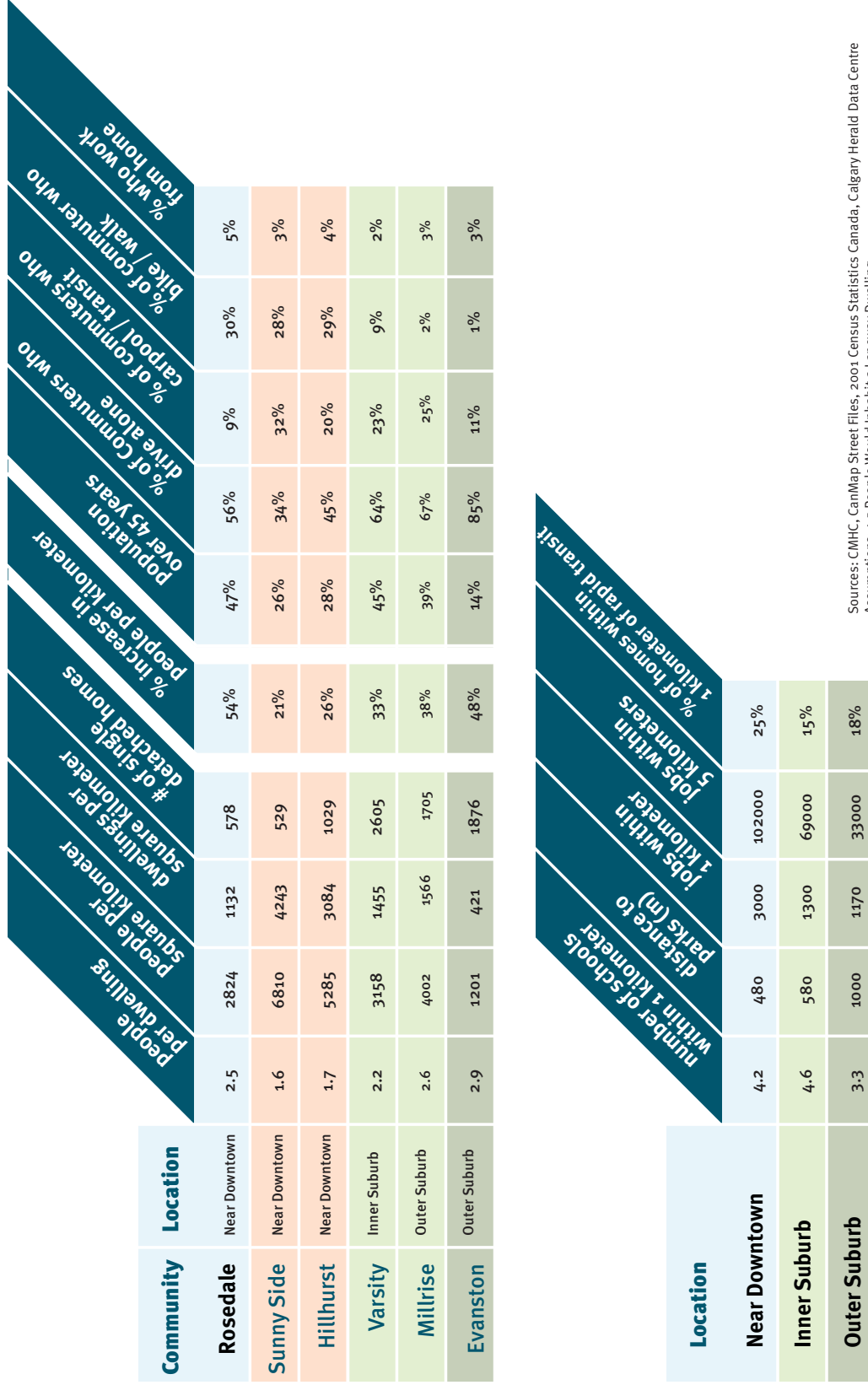

Sources: CMHC, CanMap Street Files, 2001 Census Statistics Canada, Calgary Herald Data Centre  
 Assumptions: 1.5 People Would Inhabit a Lane-way Dwelling

Comparison between seven Calgary neighbourhoods in three geographic zones: Near Downtown, Inner Suburb and Outer Suburb. The chart examines the efficacy of the land use as well as commuter trends.

## Neighbourhood Comparison

The chart displays a neighborhood comparison of seven Calgary communities to determine what site would be best to conduct an experiment of a laneway development. The variables used in the study included the number of developable single detached homes, proximity to jobs and amenities, as well as the current density per square kilometer.

Of the surveyed communities, Rosedale was chosen as the ideal site for this experiment. Rosedale was originally developed in 1910 as a middle-class single-family neighborhood. The area was developed using the initial planning approach of a street grid pattern. It is within walking distance to the downtown, Rapid Transit Stations, SAIT (Southern Alberta Institute of Technology) as well as 16th Ave, which is a major commercial corridor. The Calgary density distribution map illustrates the relative densities of each Calgary community. Of all the communities in the near downtown area, Rosedale has the highest landmass per capita. The average person per dwelling in Rosedale is 2.5. With the assumption that an average of 1.5 people would live in a laneway dwelling and that every developable lot would build a secondary suite, the community would benefit from a population increase of 54%. This site is currently underutilized but shares physical contextual attributes of both Japan and Marzobo. The laneway is a similar scale to both case studies with a street width of 18 feet as well as sited in one of Calgary's oldest most established neighborhoods.

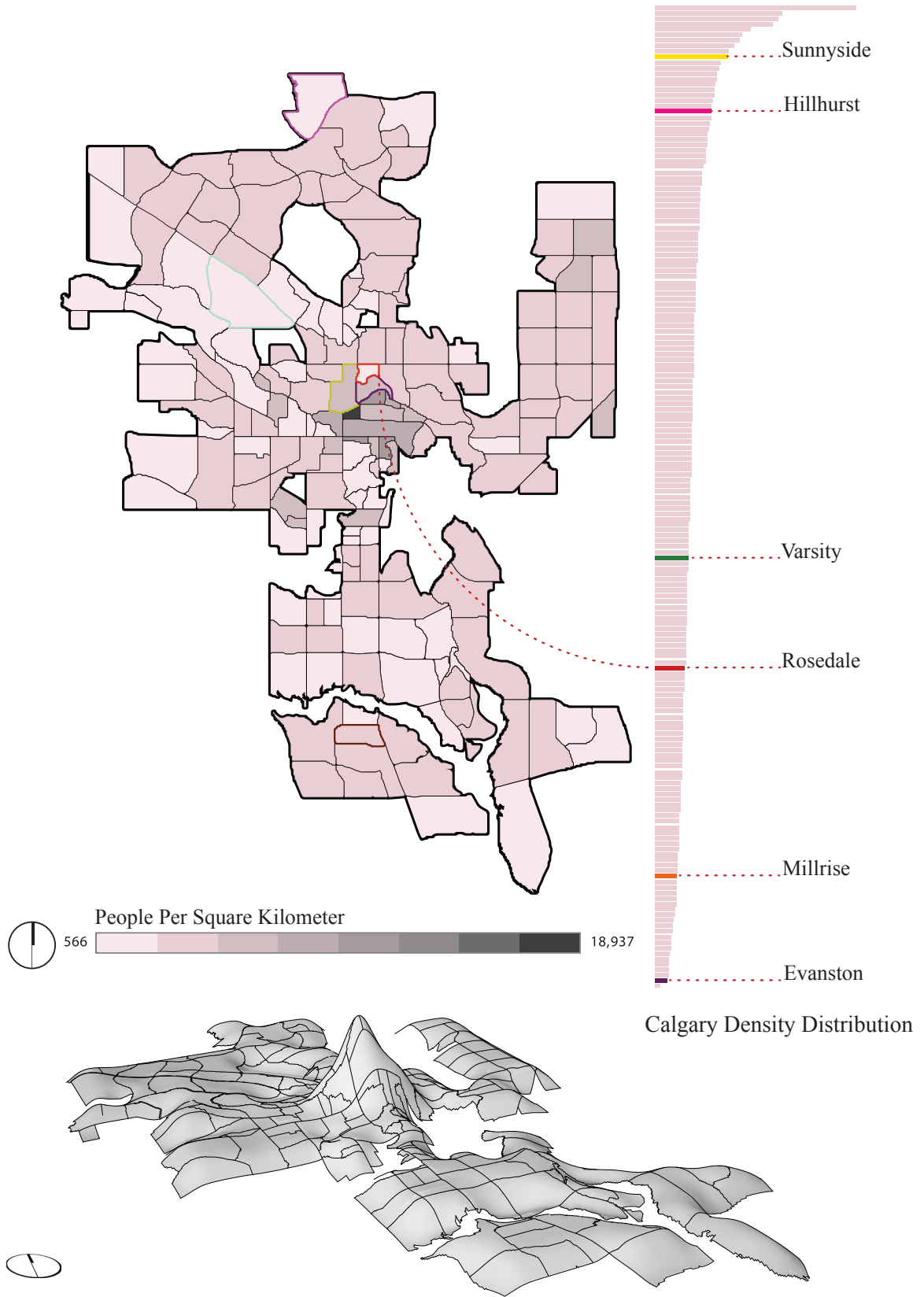

Above: Relative density surface map. The two drawings are made using adapted information from the Calgary Herald, 2012.

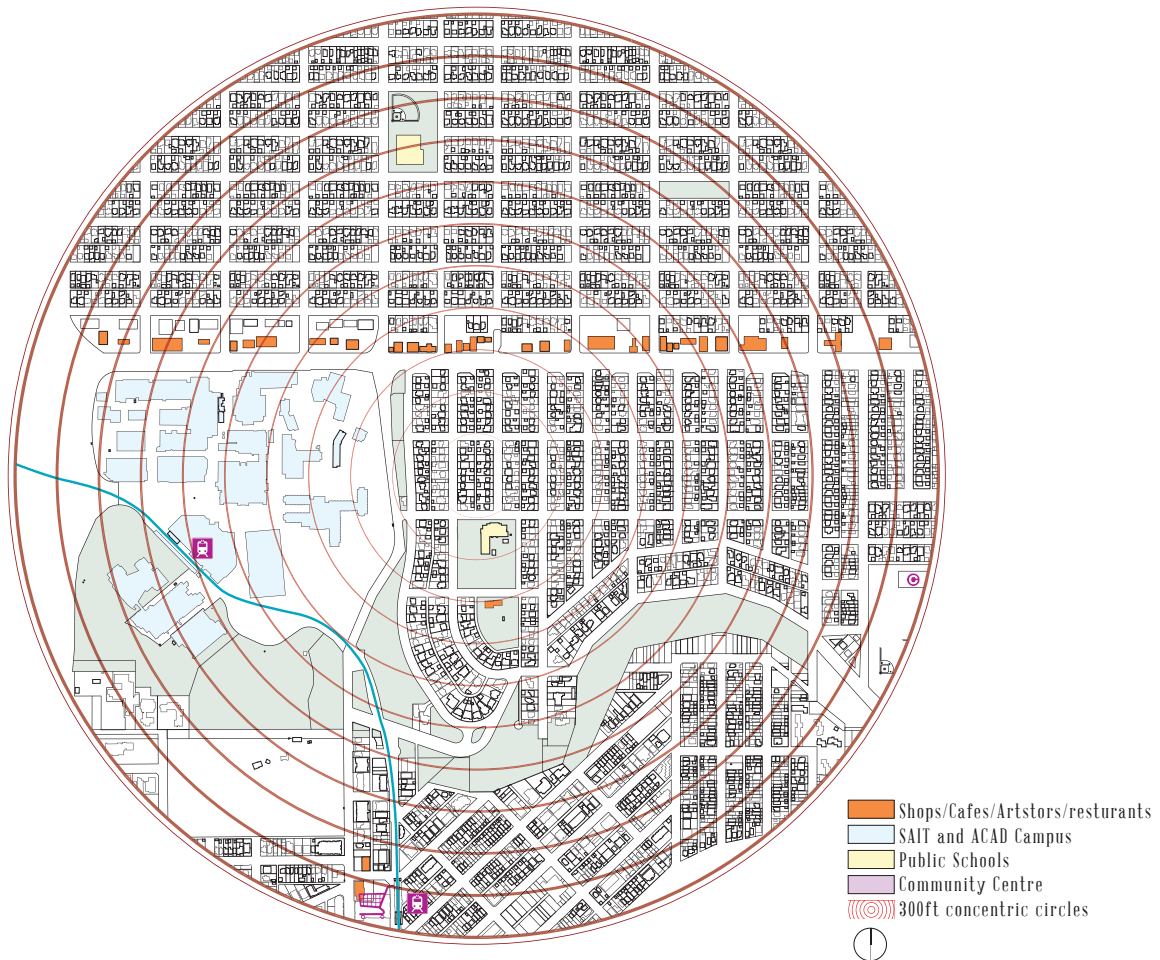

Map of amenities around the Rosedale community. Drawing illustrates site proximity to public transit, shops, schools and post secondary campus's. (City of Calgary, 2011)

## Program

### What are Their Uses?

Calgary is a rapidly growing and advancing city. Calgarians are eager to find housing solutions to suit their changing needs from fluctuating family sizes, wanting to work from home or a desire to live close to the city's core. This need for adapting building and planning regulations is illustrated in the study commissioned by the University of Calgary Student Union. The poll shows an overwhelming response by Calgarians in favor of secondary suites in existing communities.



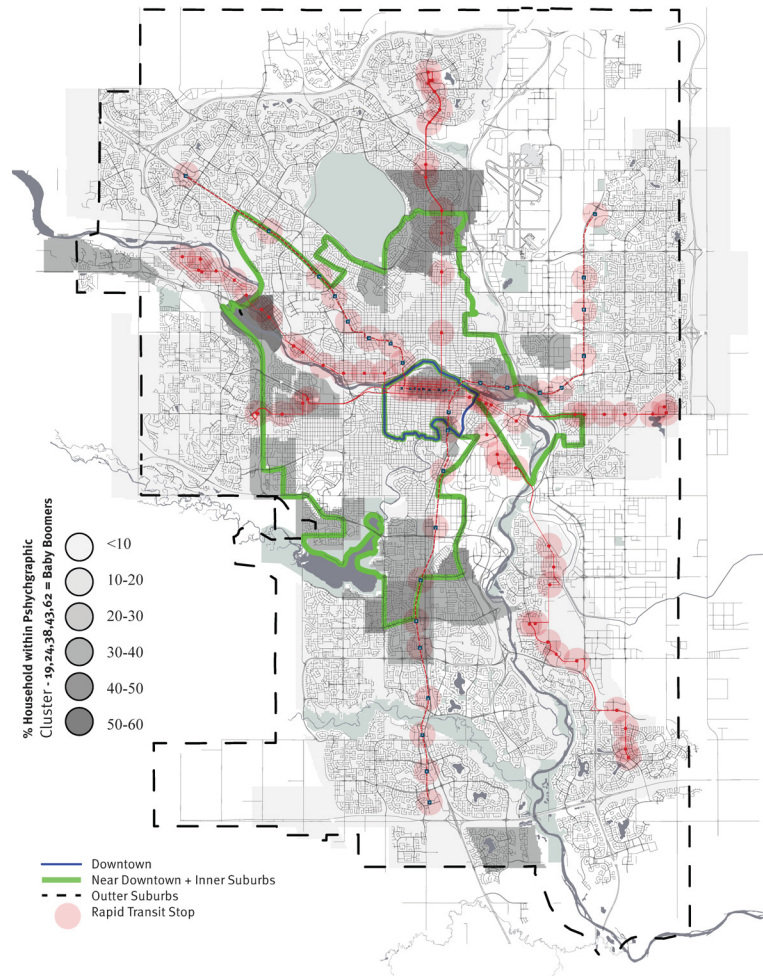

Area map shows the primary areas where the baby boomer profile lives in the city. The red dots represent a 500m diameter around Rapid Transit Station in Calgary. (Mount Royal University 2011)

By using Psychographics (psychographic variables are the use of demographics to determine the attitudes and tastes of a particular segment of a population, as in marketing studies (Dictionary.com 2012)); it is shown that the primary demographic of homeowners in the inner suburb is older, upper-middle-class homeowners that are increasingly empty-nesting. The map shows that this demographic has the highest level of home ownership in the inner suburbs.

A study commissioned by Time magazine in 2011 found that 85% of new college grads move back home with their parents (Ho 2011). The utilization of a laneway dwelling by this demographic as they transition from college to career would allow parents and offspring to maintain a level of independence and privacy to which each had become accustomed. The secondary dwelling could also potentially serve as a rental property in turn providing additional income to offset living costs. There is also the possibility an elderly couple may choose to down size to a laneway house. This would enable them to remain in their established community while renting out their main dwelling. Jane Jacobs argues that lively neighborhoods must have a sufficient density of people with diversity in culture as well as creating a diversity of dwellings. Building should vary in age and condition to accommodate varying backgrounds (Jacobs 1993, 197).

Calgary is a city teeming with creative people and an incomparable entrepreneurial spirit. On a per capita basis, Alberta has the highest number of small businesses in the country. In 2010, there were 39 small businesses in the province for every 1000 people, far exceeding the Canadian average (Alberta Government 2011, 13). Giving consideration to the sites proximity to the downtown as well as the entrepreneurial culture in Calgary, laneway housing should be adaptable to facilitate the possibility of a small business.

Another potential group of users would be young families with school-aged children who do not want long commutes. Schools and employment within walking distance or near a Calgary Rapid Transit Stop creates a more productive lifestyle with less travel time. As the result of the second income generated from a rental suite a young family would be able to afford a house and lot in the inner suburb close to downtown. This demographic could also use the suite as an office for a home business, a home for aging parents or expandable room for a growing family.

### Baby Boomer



### Young Family



### Small Business



The drawing indicates a mix of possible uses and users of a laneway dwelling.

Those who would want to rent the laneway dwellings from the homeowners could be households that want the financial benefits of living closer to the core such as walking to work, the train station, or the grocery store, as well as requiring one family car, if any. A feasibility study was conducted to understand the economic viability of a laneway home.

The sub-study, conducted with fellow contributors graduate student Clayton Blackman and Dr. David Roach, Associate Professor at the Dalhousie School of Business and Director of the Norman Newman Centre for Entrepreneurship, was to develop an in-depth feasibility study that would allow for the developer of a Secondary Suite to be profitable, the home owner who is building a Secondary Suite to be profitable while at the same time provide affordable housing for the lower two income quintiles who are spending more than 30% of their income on housing.

The lower two income quintiles in Calgary are represented by households that make between \$10,000-\$30,000 a year, with affordable housing for these people ranging from \$250-\$750 a month. As part of the Enterprise Housing Program the municipal government has set up a granting fund of \$25,000 per dwelling for homeowners to build a Secondary Suite which is designed to stimulate the private and non-profit sectors to produce affordable housing. Home owners who accept the grant must commit to rent the suite based on a prescribed rate designated by the Enterprise Housing Program for five years.

The downtown area averages between \$1090 - \$1133 a month. Unfortunately, even with the grant for laneway housing, the dwellings only start to become affordable to households that make at least \$35,069 a year, excluding the lowest two income quintiles. However, this does offer an opportunity to provide better affordable housing for people in the third lowest quintile of renters. The \$25,000 subsidized the tenants rent for five years while helping the homeowner initially finance the secondary suite. Unfortunately we could not develop a solution that was profitable for both the developer and homeowners as well as offer long term affordability for the lower three income quintiles. However I do see it to have potential to offset mortgages for young families to be able to buy in an older community and provide market rent prices to households that wish to also live close to amenities that are offered in areas close to the city core. (Please see Appendix A for further information).

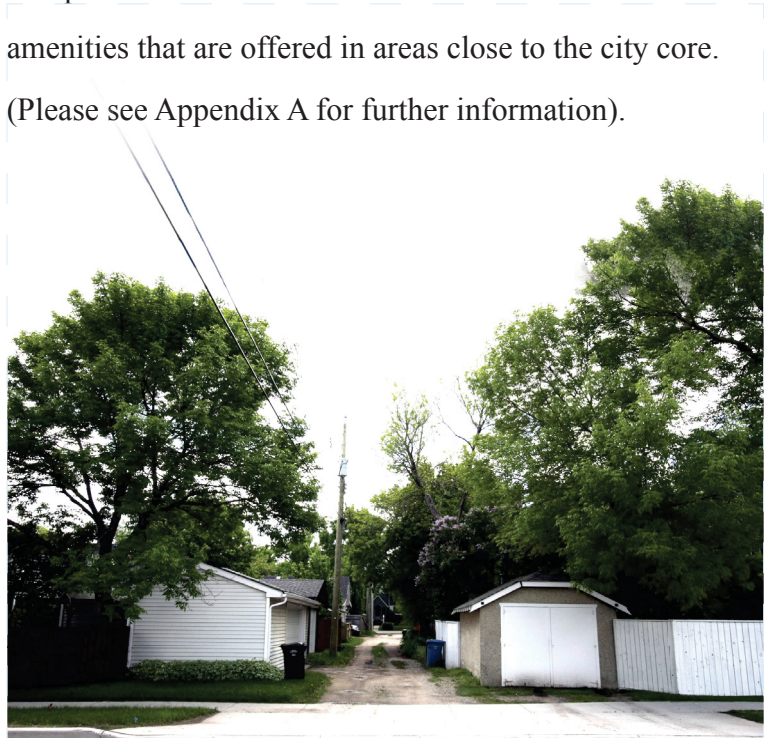

Rosedale alley entrance

## What Can a Garage Be?

New zoning proposals for Calgary's laneway housing is that any laneway dwelling within 500 meters of a Rapid Transit Station (RTS) does not need to provide that dwelling with a fixed parking stall. The intention behind relaxing the zoning around RTS is to enable more riders who are dependent on the system to live closer to the transit station. The red dots (located on the map on page 34) indicate a 500 meter radius around the hubs which is considered to be an appropriate scale for pedestrians.

A large amount of programmable space is available when the area is not required to have a fixed parking stall. This land could be used to facilitate a small business such as a small professional practice, a repair shop, artist studio etc. Such local amenities could also reduce the car dependency for the rest of the community.

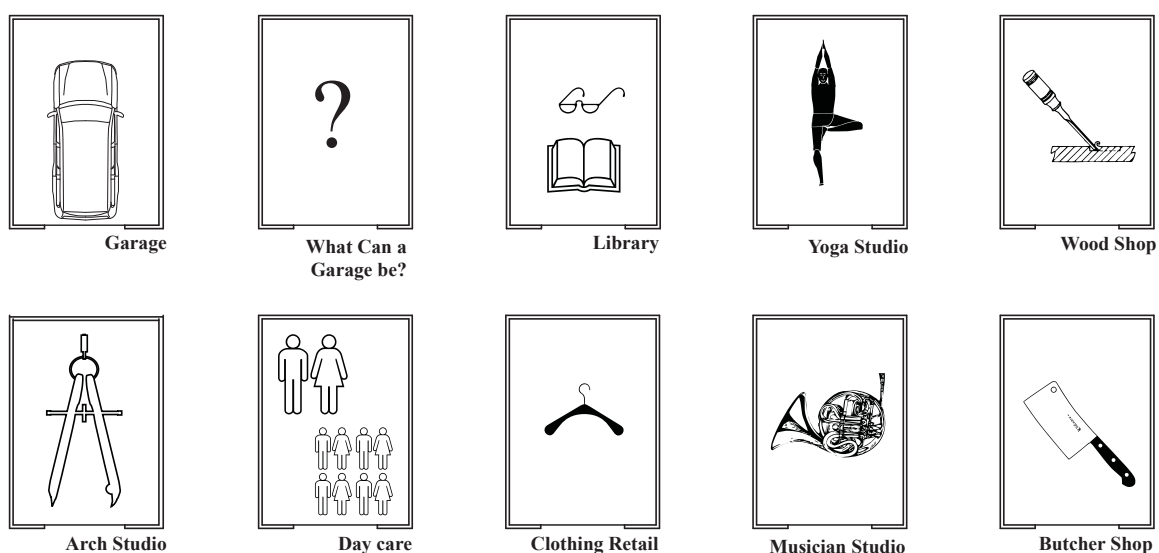

Diagram illustrates possible uses for a garage space when a resident no longer needs a vehicle.

## CHAPTER 4: DESIGN



Site model of alley including dwelling intervention.

### **Incremental Change**

This study relies heavily on observations made through case studies, travelling and working.

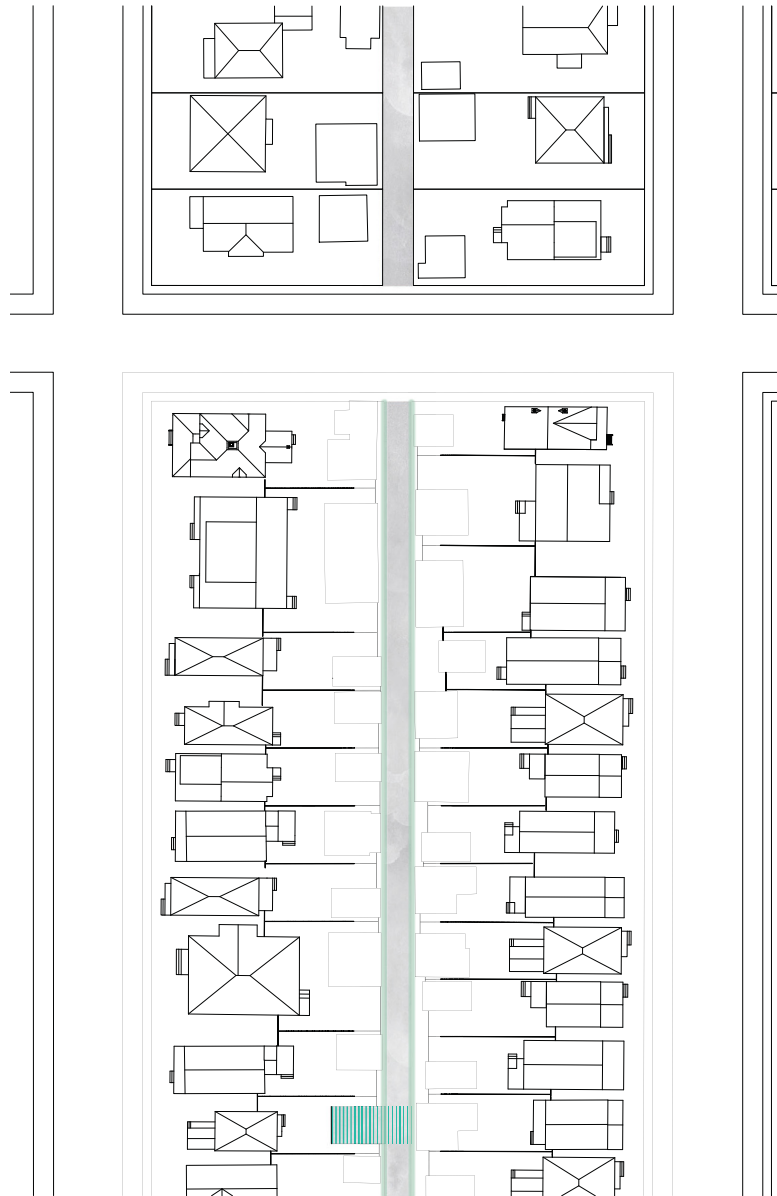

Existing laneway condition in Calgary.

The above diagram depicts the laneway as most commonly seen today in an unmanicured state, overrun with plant life and used primarily as a utility road. The drawing on the following page illustrates the potential development of a laneway over a period of time.



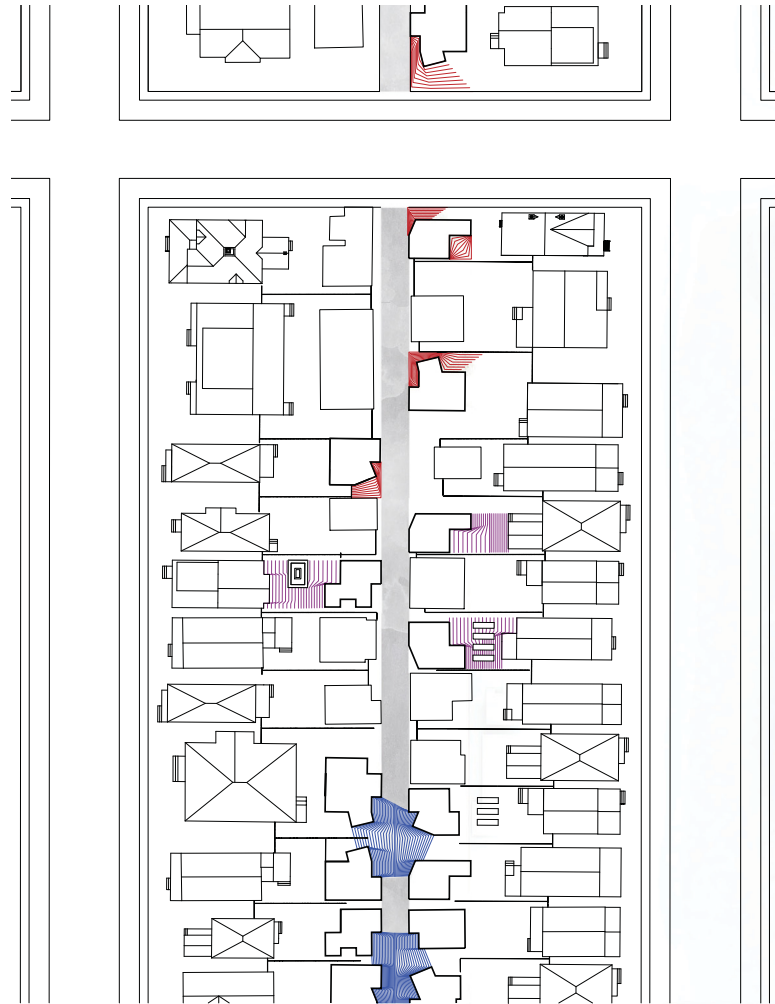

The red lines represent a multi- programmable space in front of the living portion of the house that has the possibility of borrowing space from the alley. The purple line shows the formal relationship that can be made in the rear yard between the main home and lane dwelling. The potential of the blue lines is once the lane is developed a courtyard space can be shaped with the building facades.

Understanding that the laneway will develop in small increments, the study felt that it is important for the independent dwelling to be able to create micro areas of programmable space. As demonstrated above, the desire of the form is to function as a stand-alone building and as the laneway develops over time the wedge shape voids(seen in red), create formal relationships between buildings to create communal yards, (seen in blue).

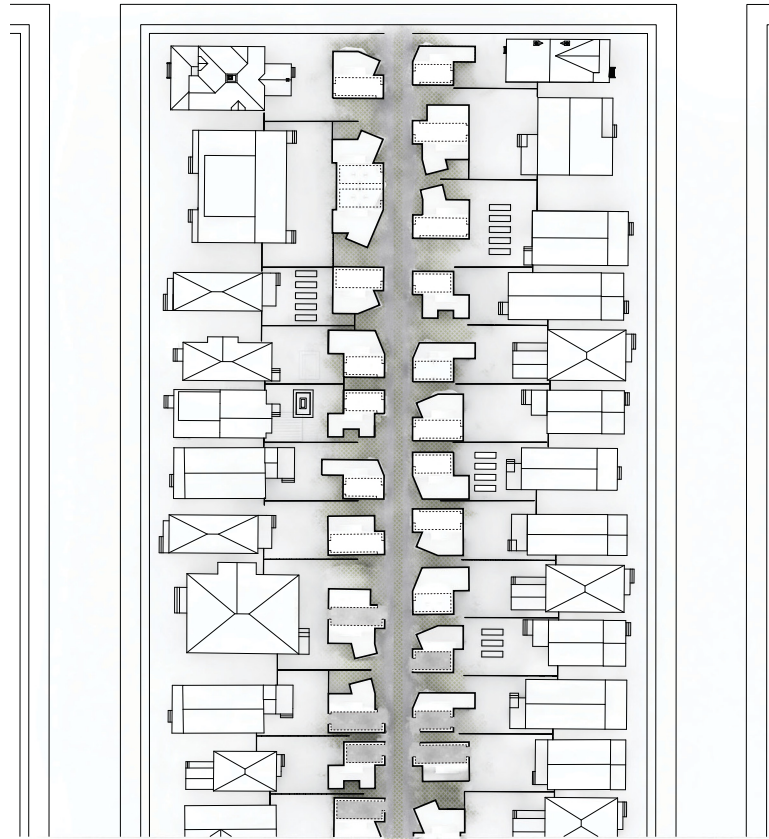

In the drawing the ground condition of the alley expands into the front and side yard as well as along the fractal edge of the buildings. The facades create a roughness and more building surface area adjacent to the street and more possibilities for the dwelling and their inhabitants to interact with the alley.

The intent for the house facades to turn into a central node is to transform the alley into a flex space. Where the alley and the dwellings meet there is a blurred boundary condition that allows the program of the house and garage to flow into the alley and that space can be temporarily annexed by the lane dweller. This is illustrated above; the ground condition of the alley expands into the front and side yard as well as along the fractal edge of the buildings. The facades create a roughness and more building surface area adjacent to the street and more possibilities for the dwellings and its inhabitants to interact with the alley.



Site model examining the difference in scale between the alley and the main

## Community and Landscape



Drawing on the left is the current existing alley condition. Drawing on the right proposes a strip of grass pavers to transform the alley from a car scale to a sidewalk / pedestrian scale.

As studied from the investigation of Kyoto, the metropolitan is activated with an abundance of plant life. This project sees a potential for landscape as a means of informing a community space. In the diagram above on the right the alleyway is divided with a strip of grass pavers, transforming the alley from a car scale to a pedestrian, sidewalk scale, while still allowing the passage of cars.



The alleyway is divided with a strip of grass pavers, transforming the alley from a car scale to a pedestrian, sidewalk scale, while still allowing the passage of cars.

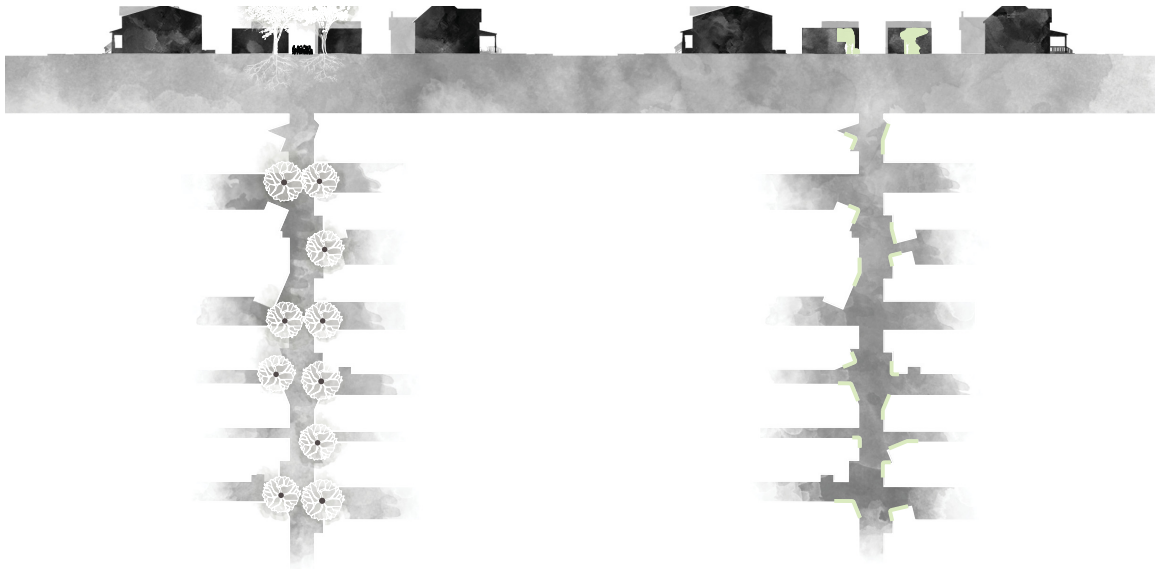

Drawing on the left illustrates how trees can be planted to inform community spaces as well as create a sense of enclosure. Drawing on the right sees the potential for plantwalls as a means of creating a sense of place.

The alley offers an intimacy that cannot be achieved on the main street because of the width of the road and setbacks of the houses. The narrowness of the alley can be used to create a sense of enclosure where trees can be strategically planted in communal areas and eventually develop a network of connecting tree canopies, creating sheltered outdoor gathering areas.

Growing is a community act. The plant walls in Appendix B are intended to foster civic interactions. The plant wall can be a place of beauty, recreation and gathering for everyone in the community.

## Settlement Pattern

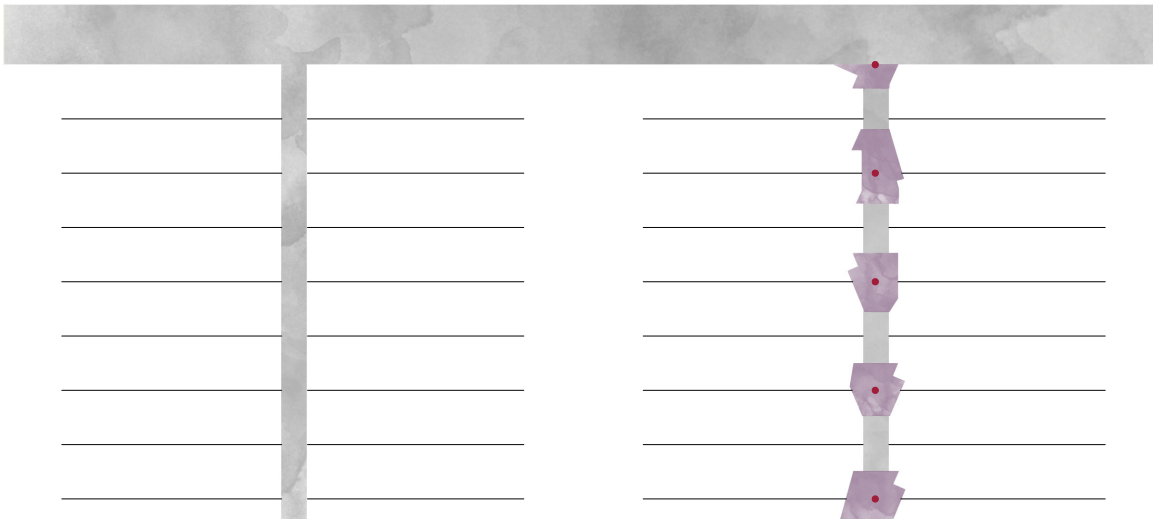

Drawing on the left indicates the existing laneway condition and property lines. The proposal in the drawing on the right is to designate every other lot line with a node. The node is a design guide for lane development to create communal yards over time.

A rule base system was defined as a strategy for defining an urban plan to develop a laneway. Nodes are placed every second lot line. This framework of evolution provides a home owner a departure point for their design that includes the creation of a communal front yard.



Communal area focused around a node.

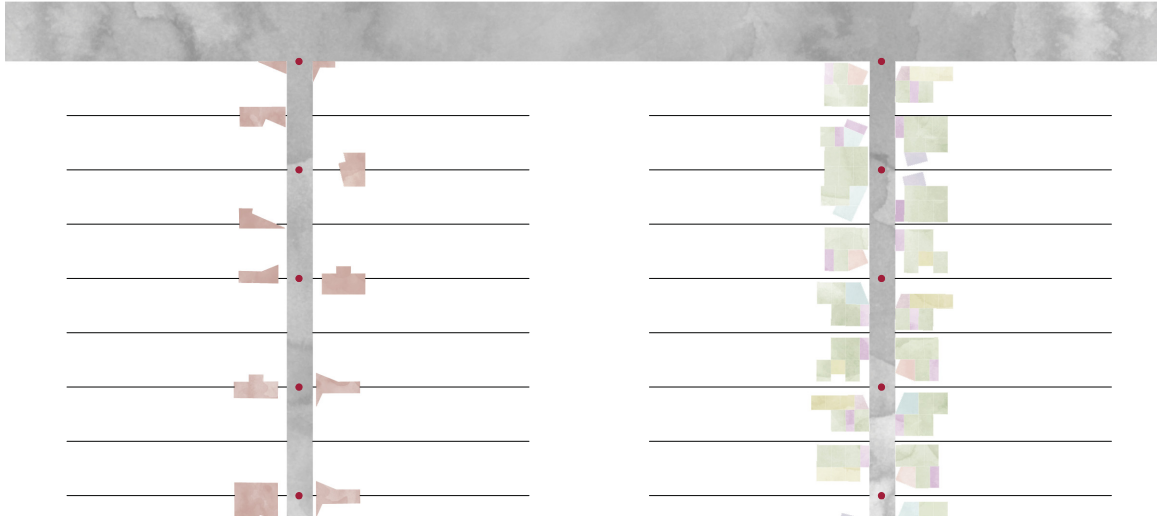

The drawing on the right indicates that side yards can be created if entryways are faced adjacent to each other. The drawing on the left uses seven standard geometries to configure house floorplans in a number of configurations.

As the living realm of the dwellings is facing the nodes, the garages are justified towards each other. As a result the side yards between the dwellings open onto each other, informing a smaller community area.

It is this reports intention to translate observations appropriated through research in Kyoto to the laneway built typology. This study used seven building blocks that can be choreographed in a multitude of configurations to develop a series of unique dwellings that can conform to the sought out urban plan.



Entrances into the lane dwelling activate a shared side yard.

## Dwelling Pattern

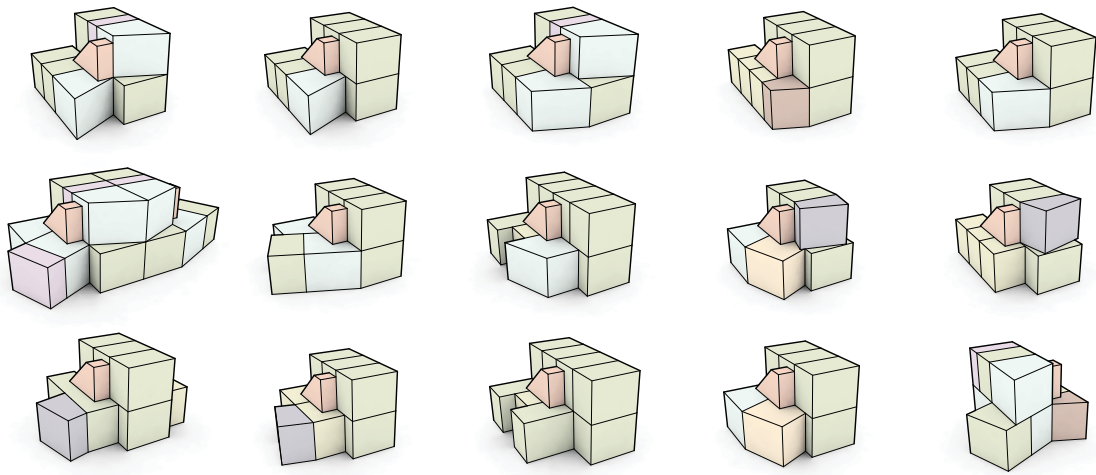

A multitude of house arrangements that are generated using seven standardized geometries.

The geometries are based on eight and twelve foot wide dimensions. These dimensions are chosen based on necessary room dimensions of a garage, kitchen or bedroom.



1:100 site model illustrating the courtyard space created around a central node.



### Parameters A

- Garage space, zero building setback
- Living space, 4 ft building setback
- Zero side setback
- Maximum height of 35 ft

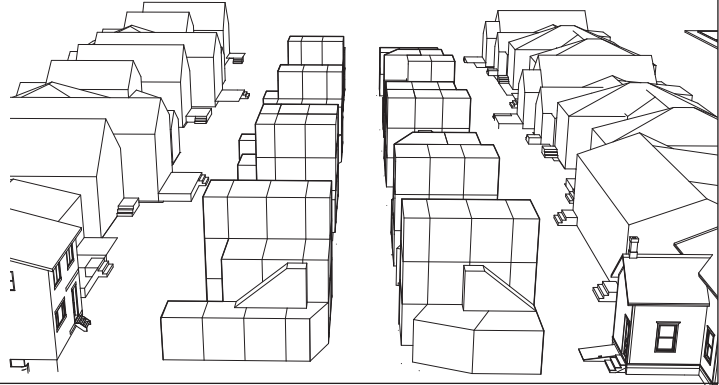

Laneway homes with a possible maximum height of 35ft allow for the option of a larger dwelling as well as a smaller footprint. The increased height casts large shadows and may raise above the primary home.

### Parameters B

- Garage space, zero building setback
- Living space, 4 ft building setback
- Zero side setback
- Maximum height of 25 ft

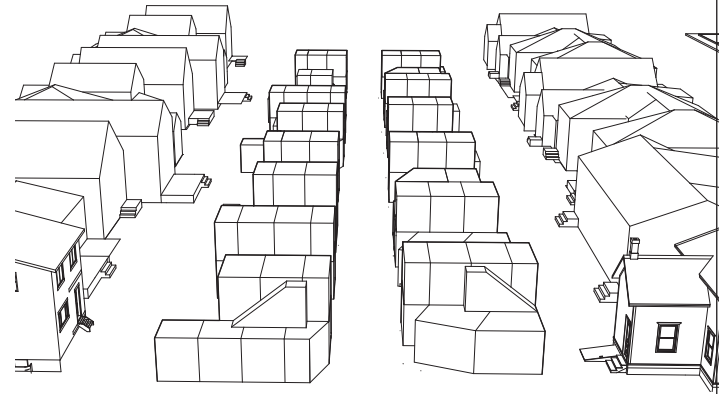

Laneway homes with a possible maximum height of 25ft allows for a two story dwelling and a modest size footprint for living space. The overall height is lower than the main dwelling and casts minimal shadows.

### Parameters C

- Garage space, zero building setback
- Living space, 4 ft building setback
- Zero side setback
- Maximum height of 15 ft

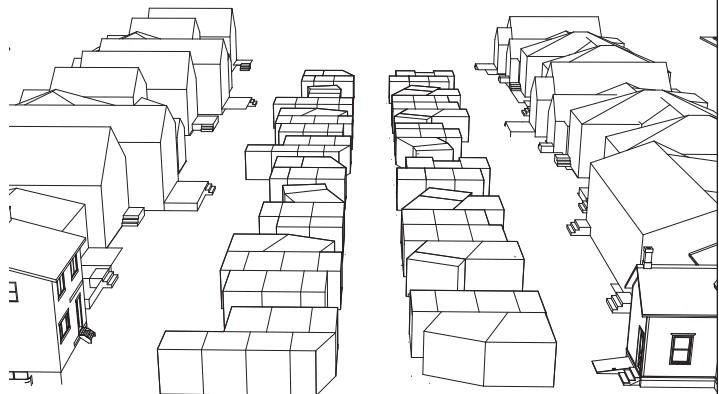

Laneway homes with a possible maximum height of 15ft allows for a one or one and a half story residence. The dwelling sizes are small, at the scale of a bachelor style apartment.

This project followed Parameters B as a guide for development. A maximum height of 25 ft allows for a second story and increased occupancy as well as minimizes the size of the shadows cast onto neighbouring lots. The zero side setback makes it possible for two garages to be justified directly beside each other to create a large side yard between its neighbouring laneway. It is this scale that this study believes has the lowest built impact and possibility for an increased occupancy.



Possible zero side setback (red line) makes it possible for two garages to be justified directly beside each other to create a large side yard between its neighbouring laneway (orange line).

In housing there is a sensitive relationship between public and private spaces. The intent of the dwelling floor plan is to match the public, communal and private realms of the house with the respective realms of the laneway. This study views the kitchen as the most active and public domain of the residence and so it is designed to be adjacent to the alley. The living area borders the backyard and the bedrooms are elevated to the second floor for privacy and acoustic separation from the alley and living quarters. In Figure E, the floor plan illustrates how the kitchen can borrow space from the alley and how the living area can spread into the backyard and visa versa.



The kitchen has the possibility to be an extended appendage of the alleyway.



Courtyard Plan



## Interiors



Transformation of a dwelling throughout the day.

Similar to the ability of the alley to adapt to change for different purposes, the interior of the house has a similar aptitude. Shown in the interior drawings, the house can transform from a place for a family to have breakfast to a small office or an open space suitable for a gathering.



Transformation of a dwelling throughout the day.

## Community Scales

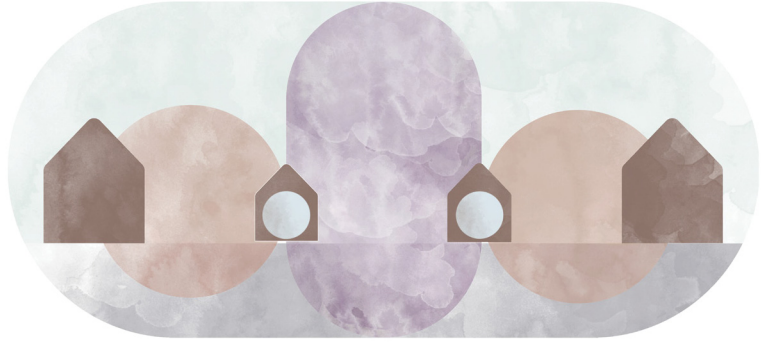

Diagram illustrates how a neighbourhood is comprised of a number of different parts that collectively work together.

The intent of the drawing above is to diagram Aristotle's quote that 'The whole is greater than the sum of its parts'. This thesis envisions laneway dwelling as contributing a new layer to an existing urban fabric to create more livable communities. At a neighborhood scale the laneways allow for an increase in density and possible uses such as small businesses. The alley, side and backyard offer varying degrees of public community domains. The adaptable interiors allows for a variety of possible community spaces.



Garage is converted into a bicycle repair shop. The small business offers a new local amenity to the neighbourhood.





The ambition of the above drawing is to demonstrate the potential for a multitude of ways in which the alley may be used. As well as being a space of community gathering it also lends itself to the possibility of small businesses such as the bicycle repair shop in the rendering or perhaps an accountant's office or an artist's gallery, adding to the local amenities of a neighborhood.



The need for privacy and security is very important to the dwellers wellbeing. The opaque and frosted glass panels on the outside of the facade move on rails. This gives the dweller control to choose when to open their house to the alley.



Sectional perspective through laneway dwellings and existing homes.

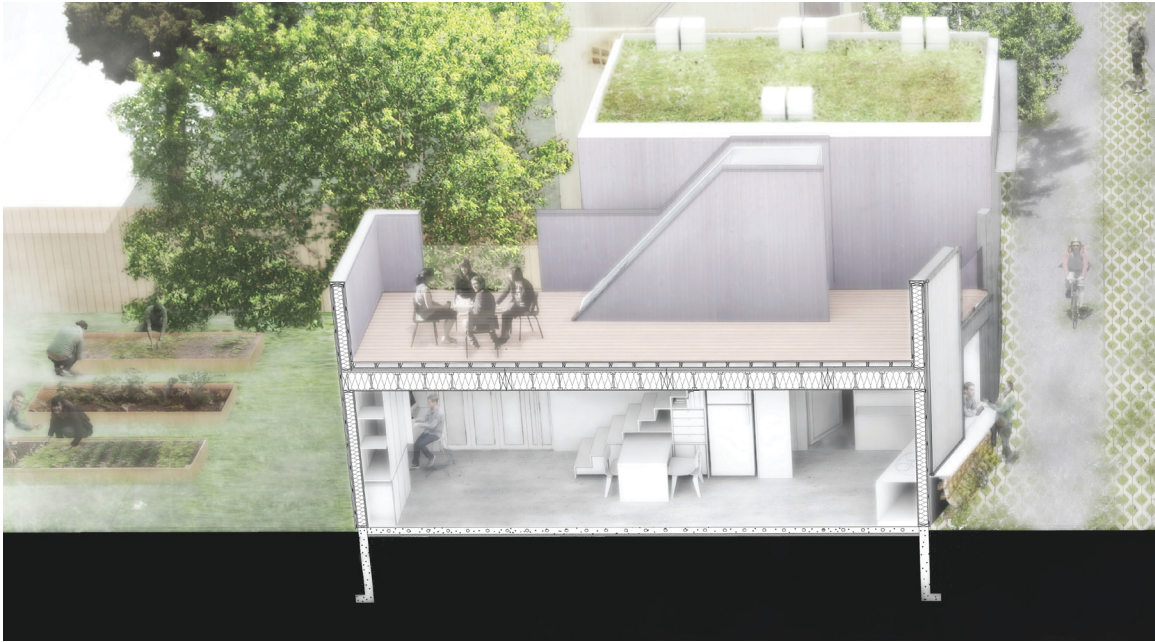

This section illustrated the minimum transition in elevation from inside to out. This is designed so that as the dweller is preparing their meals or washing their dishes they can have an opportunity to interact with their neighbors, or oversee their children as they play outdoors.

While a student in Calgary I ran a carpentry business from my family garage. Every day as neighbors went about their business, walking the dog, collecting the mail or driving by, many of them would stop by to inquire about my current projects. Over time, through these interactions, I came to know my neighbors and others in the community and after building those connections some became customers. Taken from my observations of working in my garage, this study sees the potential for the special relation of the kitchen to the alley as an important community builder. Shown in the section there is a minimum transition in elevation from inside to out. This is designed so that as the dweller is preparing their meals or washing their dishes they can have an opportunity to interact with their neighbors, or oversee their children as they play outdoors.



The height of the garage door is lowered to seven feet to change it from an automobile scale to a door / pedestrian scale. The door also partly opens to one side to allow for the alley to be used as extended project space.



The railing on the patio above the garage is raised to five feet to allow for a higher degree of privacy when in the space.



Sun shelves are located on windows to function as both a means to bounce natural light further into the dwelling as well as to create a blocked view plane from the alley into the bedroom to create privacy.



The backyard space has the potential to be a connecting domain between the main residence and the lane dwelling.



This firepit is a shared hearth between the main home and lane home.



Corner of the garage opens to the alley.

## CHAPTER 5: CONCLUSION

In summary, there are a number of observations that I have made over the past year while working on this project. Firstly, is the importance of drawing upon your personal observations, experiences and travels and to select the ones that resonate with you as places of joy. There is incredible value in studying successful urban centres and the works of others before bringing together those qualities of space which allow you to create a place that you enjoy.

This thesis found inspiration in the streets of Kyoto and largely in the works of others. I sought to build on these valuable existing ideas, appropriating and adapting them into a built form which would fit in to the urban context of Calgary.

Through the entire design process I found motivation in realizing that the environment that we create has potential to improve the lives of the inhabitants. As designers, we must strive to create spaces which inspire people to interact and explore.



Densification around central amenities make cycling a more viable transportation solution.

## **APPENDIX A: FEASIBILITY STUDY**

According to the 2006 Canada Census, of the 107,045 households that rent, 42,204 spend more than 30% of their household income on housing costs. Housing which is affordable per household is recognized by CMHC as a maximum of 30 per cent of the household income spent on shelter. This sub-study, conducted with fellow contributors graduate student Clayton Blackman and Dr. David Roach, Associate Professor at the Dalhousie School of Business and Director of the Norman Newman Centre for Entrepreneurship, was to develop an in-depth feasibility study that would allow for the developer of a Secondary Suite to be profitable, the home owner who is building a Secondary Suite to be profitable while at the same time providing affordable housing for the lower two income quintiles who are spending more than 30% of their income on housing.

Prefabrication was of interest in this project because of the potential for modular design systems that could flex for different site conditions and user needs while using components that offer similar design details. Prefabrication was also considered because of Calgary's shortage in skilled trades and high building costs in hopes of utilizing faster project delivery times and to reduce cost for implementing laneway dwelling as a means of affordable housing.



The downtown area averages between \$1090 - \$1133 a month. Unfortunately, even with the grant for laneway housing, the dwellings only start to become affordable to households that make at least \$35,069 a year, excluding the lowest two income quintiles. However, this does offer an opportunity to provide better affordable housing for people in the third lowest quintile of renters. The \$25,000 subsidized the tenants rent for five years while helping the homeowner initially finance the secondary suite. Unfortunately we could not develop a solution that was profitable for both the developer and homeowners as well as offer long term affordability for the lower three income quintiles. But I do see it to have potential to offset mortgages for young families to be able to buy in an older community and provide market rent prices to households that wish to also live close to amenities that are offered in areas close to the city core.

Typical Installed Cost	Typical Revenue	Return on Investment
1. Lane Home 650-1110 sq ft, Design + Construction: \$176,000 - 228,000	Subsidized Housing for 5 years \$877 a month.	Renting of the Laneway Dwelling
2. Site Specific costs: Sewer and water upgrades demolition and landscaping, new electrical service \$15,000-\$25,000	Dwelling 650 sq ft 2 Bed + Flex Garage \$1100-1400 / Month	Typical Rental Suite: Building (installed) \$200,550
4. Typical Dwelling Cost = Lane Home + Site Specific Costs + GST	Dwelling 1110 sq ft 3 Bed + Flex Garage \$1100 - \$1850 / Month	Monthly Revenue \$1,100 Renters Contribution \$877 Grant subsidized rent \$223 Yearly Revenue \$13,200
~\$200,550 - \$255,000		Rental Occupancy 95% - \$660 Maintenance and Tax 10% - \$1,320
<b>Municipal Incentives</b> The city of Calgary is offering \$25,000 grants to home owners building a new secondary suit on their parcel of land. The homeowner must commit to renting the dwelling for nomore then average market rent for a Secondary suite (\$877 /month) for five years.		<b>Net Annual Revenue</b> \$11,220 Annual Payment, Loan Amortized over 30 Years at 3.5% with 20% down \$7,350 <b>Gross Annual Profit</b> \$3,850

Results of a cost analysis of the estimated construction of a laneway dwelling compared with market rent of similar housing in the near downtown area. (CMHC 2011)

## APPENDIX B: PROGRAMMED DETAIL

The previous research in automation was utilized in creation of a site specific rain screen system. The concept for this detail was to create a greenwall that could be optimized for a variety of plant life and different solar conditions on different sites. Using a solar irradiance definition in the parametric software Grasshopper, developed by the University of Oregon's Solar Radiation Monitoring Laboratory, a gradient color scale can measure the amount of solar radiation transmitted on to a surface. After optimizing the surface and adjusting it for a veritable amount of solar gain, the surface can then be translated to a separate structural definition that can then output the greenwalls complex geometries to the CNC router.

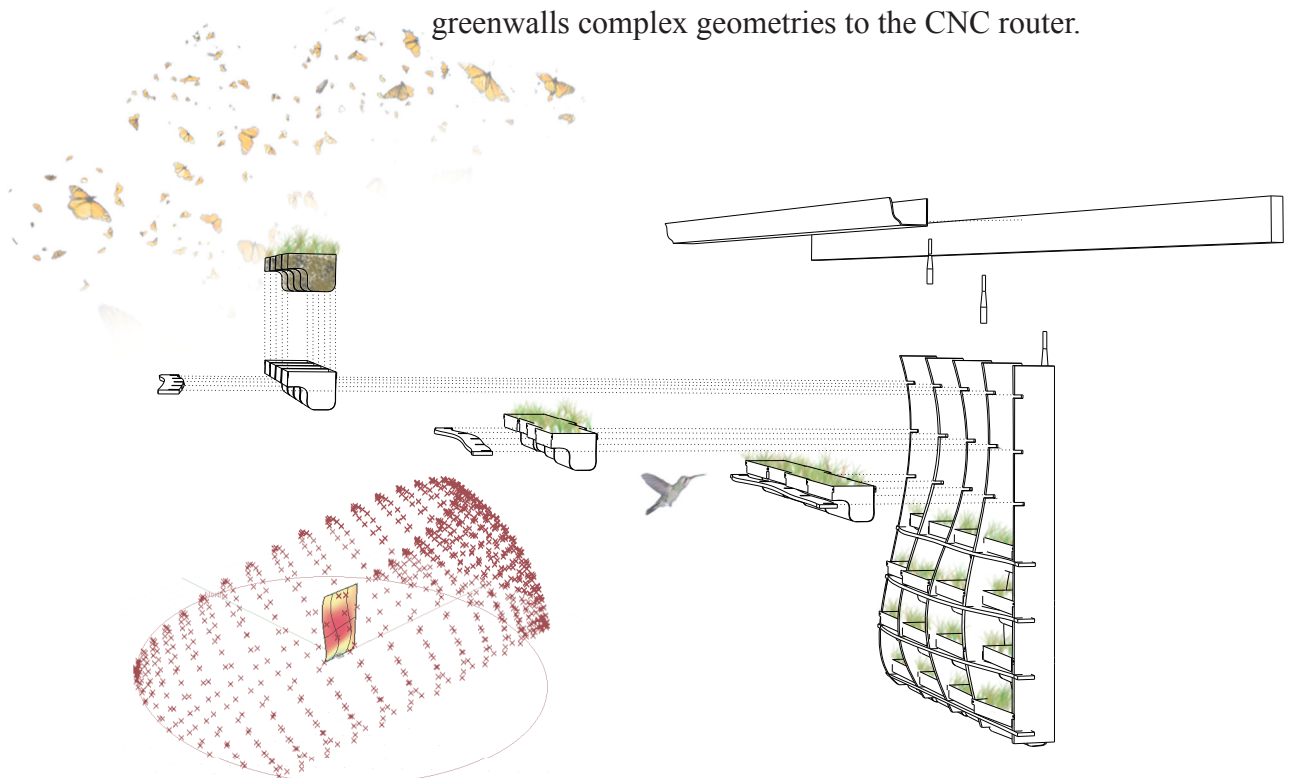

Left, diagram of solar intensity on surface. Right, construction diagram of plant wall.



Spring

Summer

Fall

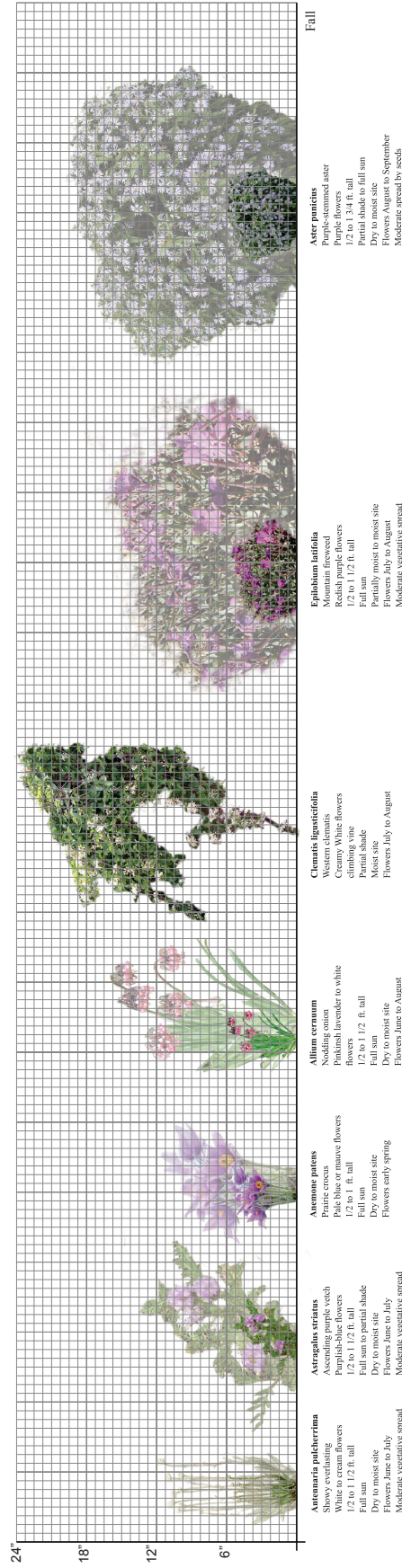
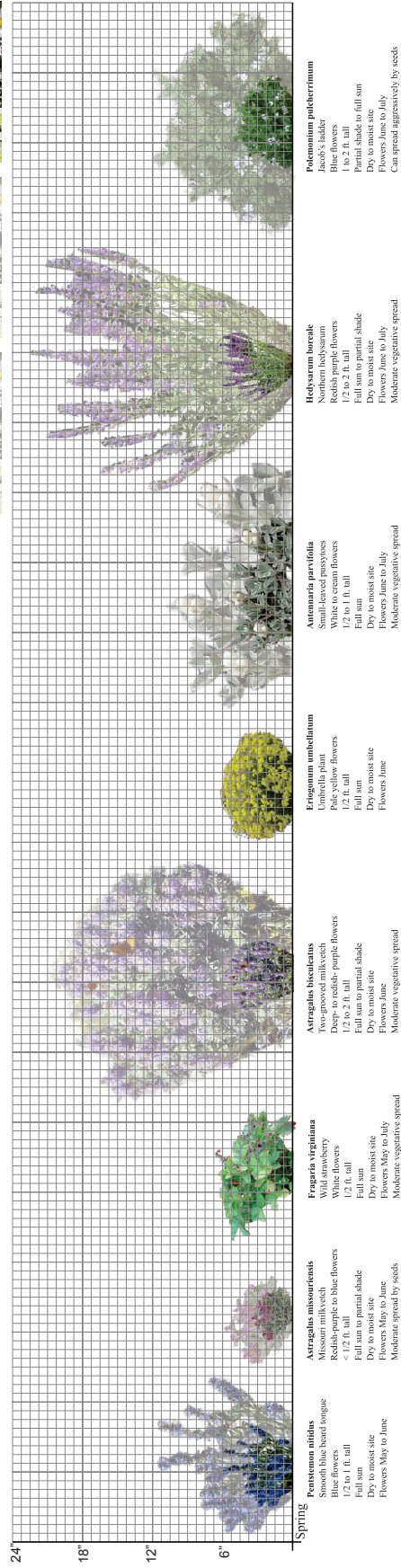

If the user wants to plant a flower garden below chart illustrates the bloom cycles and average plant growths of native plants to Calgary. These are plants that need very little maintenance to thrive in the prairie environment.



Diagram illustrating the community act of gardening.

The above charts built from information conducted by the National Gardening Association show that gardening is predominantly done by middle age people nearing retirement. This fits into the demographic this study is aiming to target. As baby boomers are retiring they are spending more time in their gardens both as a hobby and physical activity. I see the plant wall as a community building activity encouraging interactions with tenants and neighbors. It is also aesthetically beautiful and can be tailored with various plant life to attract a number of different birds, bumble bees and butterflies.



Studio Garden: It's a Hit! Students enjoy adding fresh herbs to their lunch or just take a quick moment to munch on some Sorrel.

## APPENDIX C: WORKS



Kids Camp at Malpeque Beach, Prince Edward Island, Canada



Dining Hall at Ross Creek Centre for the Arts, Nova Scotia, Canada



2011 Dalhousie float for the Parade of Lights, Halifax, Canada

The above projects were completed with the collaboration of Clayton Blackman, Mark Erickson and fellow classmates. All of the projects had a modest budget and hard deadlines. It was important for this study to be imagined as a project that could be built with an estimated cost and building parameters.

## REFERENCES

- Alberta Government. 2011. Small Business Big Impact: Alberta Small Business Profile. [http://www.awebusiness.com/Content\\_Files/Files/ABSmallBusinessProfile2011.pdf](http://www.awebusiness.com/Content_Files/Files/ABSmallBusinessProfile2011.pdf).
- Bing Maps. 2012. <http://www.bing.com/maps/>.
- Byers, Michele. 2003. Waiting at the Gate: The New, Postmodern Promised Land. In *Suburban Sprawl: Culture, Theory and Politics*, ed. Matthew J. Lindstrom, and Hugh Bartling. 23-44. Lanham: Rowman and Littlefield Publishers, Inc.
- Calgary Herald. 2012. Population Density in Your Community. <http://www.calgaryherald.com/news/data-centre/population-density/index.html>.
- Canada Mortgage and Housing Corporation (CMHC). 2001. Rental Market Report. [http://www.cmhc-schl.gc.ca/odpub/esub/64371/64371\\_2011\\_A01.pdf](http://www.cmhc-schl.gc.ca/odpub/esub/64371/64371_2011_A01.pdf).
- Canada Mortgage and Housing Corporation (CMHC). 2011. Comparing Neighbourhoods: Calgary. [http://www.cmhc-schl.gc.ca/en/co/buho/sune/sune\\_008.cfm](http://www.cmhc-schl.gc.ca/en/co/buho/sune/sune_008.cfm).
- Carroll, Michael, and Danita Rooyakkers. 2010. *Atelier Build*. Halifax: Tuns Press.
- CBC News. 2008. Half of Homeless on Calgary Streets Have Jobs. <http://www.cbc.ca/news/canada/calgary/story/2008/09/16/homeless-count-shelters.html>.
- City of Calgary. 2011. Infrastructure & Information Services.
- Diamond, A.J. 1981. *Increasing Suburban Densities: Adapting the Suburban Pattern*. Ottawa: Canada Mortgage and Housing Corporation.
- Dictionary.com. 2012. <http://dictionary.reference.com/browse/psychographics>.
- Dunham-Jones, Ellen, and June Williamson. 2009. *Retrofitting Suburbia: Urban Design Solutions for Redesigning Suburbs*. Hoboken: John Wiley and Sons, Inc.
- Ghitter, Geoff. 2010. Urban Living. More Secondary Suites; Lots More. <http://www.ffwdweekly.com/article/life-style/urban-living/more-secondary-suites-lots-more-6966/>.
- Ho, Erica. 2011. Survey: 85% of New College Grads Move Back in with Mom and Dad. <http://newsfeed.time.com/2011/05/10/survey-85-of-new-college-grads-moving-back-in-with-mom-and-dad/>.
- Jacobs, Jane. 1993. *The Death and Life of Great American Cities*. Toronto: Random House.
- Kajijima, Momoyo, and Junzo Kuroda and Yoshiharu Tsukamoto. 2006. *Made in Tokyo*. Tokyo: Kajijima Institute Publishing Co.

- Lewis, Sally. 2005. *Front to Back: A Design Agenda for Urban Housing*. Oxford: Architectural Press.
- Mount Royal University Statistics Department. 2012. <http://libguides.mtroyal.ca/statistics>.
- Nicolaides, Becky M., and Andrew Wiese. 2003. Imagining Suburbia. In *The Suburb Reader*, ed. Becky M. Nicolaides and Andrew Wiese, 163-165 New York: Taylor and Francis Group.
- Putman, Robert. 2000. Connects suburbanization to the demise of community. In *The Suburb Reader*, ed. Becky M. Nicolaides and Andrew Wiese, 492-495. New York: Taylor and Francis Group.
- Ross, W.D. 1924. *Aristotle's Metaphysics*. Oxford: Clarendon Press.
- Sandalack, Beverly A., and Andrei Nicolai. 2006. *The Calgary Project: Urban Form / Urban Life*. Calgary: The University of Calgary Press.
- Shelton, Barrie. 1999. *Learning from the Japanese City: West Meets East in Urban Design*. London: Alexandria Press.
- Veneta, Sagep. 1989. *Giancarlo De Carlo: Tra Acqua e Aria, Un progetto per l'isola di Mazzorbo nella Laguna*. Genova: Sagep Editrice.