

**Athletes' Village:
The Adaptive Reuse of Rexall Place**

by

Kurt Von Kuster

Submitted in partial fulfilment of the requirements
for the degree of Master of Architecture

at

Dalhousie University
Halifax, Nova Scotia
March 2012

© Copyright by Kurt Von Kuster, 2012

DALHOUSIE UNIVERSITY
SCHOOL OF ARCHITECTURE

The undersigned hereby certify that they have read and recommend to the Faculty of Graduate Studies for acceptance a thesis entitled "Athletes' Village: The Adaptive Reuse of Rexall Place" by Kurt Von Kuster in partial fulfilment of the requirements for the degree of Master of Architecture.

Dated: March 20, 2012

Supervisor: _____

Reader: _____

Reader: _____

DALHOUSIE UNIVERSITY

Date: March 20, 2012

AUTHOR: Kurt Von Kuster

TITLE: Athletes' Village: The Adaptive Reuse of Rexall Place

DEPARTMENT OR SCHOOL: School of Architecture

DEGREE: MArch

CONVOCATION: May

YEAR: 2012

Permission is herewith granted to Dalhousie University to circulate and to have copied for non-commercial purposes, at its discretion, the above title upon the request of individuals or institutions. I understand that my thesis will be electronically available to the public.

The author reserves other publication rights, and neither the thesis nor extensive extracts from it may be printed or otherwise reproduced without the author's written permission.

The author attests that permission has been obtained for the use of any copyrighted material appearing in the thesis (other than brief excerpts requiring only proper acknowledgement in scholarly writing), and that all such use is clearly acknowledged.

Signature of Author

CONTENTS

Abstract	v
Acknowledgements	vi
Chapter 1: Introduction	1
Thesis Question.....	1
Area of Study.....	1
Adaptive Reuse	4
Sport Facilities	8
Chapter 2: Design.....	14
Site Analysis	14
Program.....	18
Site Strategy	21
Building Design.....	24
Chapter 3: Conclusion	41
Appendix: Existing Site and Building Conditions.....	44
References	48

ABSTRACT

Currently very few retired venues are reused and most are torn down to make room for new development. Of the venues that are reused, they are either converted into housing projects or mixed use commercial buildings. My goal of reusing Rexall Place, in Edmonton, Canada, is to help prove that the reuse of this building type is a viable option, one that can save many retired venues from demolition.

The adaptive reuse of Rexall Place proposes the conversion of the large scale, sole purpose venue of the Edmonton Oilers hockey club into a multi-use facility that will continue to maintain the spirit of the building, while regenerating the urban fabric of the Northlands area. This project looks to give life back to Rexall Place, and spark urban regeneration in the communities surrounding Rexall Place by creating an accessible central hub for these communities through the inclusion of quality housing, shopping and recreational facilities.

ACKNOWLEDGEMENTS

Thank you Tamara, Jeremy, and Megan for all the support and sacrifices that you have made throughout this process.

I would also like to thank my supervisor, Richard Kroeker, and advisor, Roly Hudson, for their support, encouragement and insight over the past few months.

CHAPTER 1: INTRODUCTION

Thesis Question

How can adaptive reuse provide an architectural alternative to the wrecking ball for large scale sports stadiums?

Area of Study



Edmonton City Skyline. from City of Edmonton

This thesis focuses on the adaptive reuse of the sole purpose sport and entertainment venue, Rexall Place in Edmonton, Alberta. As such it will be important to understand sporting venues in a historical context: what they are currently, what lies in the future for such a building. These types of buildings, which no longer have a use for the sole purpose of the event, can become a local resource which gives back to the community and contributes to the life of the community throughout all times of the day and year. While the major theme of this thesis is the adaptive re-use of sporting facilities, their reuse involves a consideration of all aspects within the realm of architecture. In order to make a case for such a project one needs to consider uses other than sport facilities such as, but not limited to, urban redevelopment/ regeneration, environmental considerations, cost and building technology. While the focus of the discussion will be around urban regeneration and adaptive reuse, both sustainable design and building technology will play an important role in the final design of the building.

In the following discussion I hope to explore the

reuse of such a building as a viable construction option. As well, I hope to explore the validity of urban regeneration through the adaptive reuse of a large scale sport and entertainment facility rather than through new construction. This approach should also allow me to combine the most typical instances of the reuse of sport venues, residential housing, commercial properties and public amenities, into a central hub that will support the surrounding communities. The overall goal of combining these aspects is to provide an architectural response to addressing the reuse of sporting venues, currently in the existing urban fabric, over the current trend of tearing down to make way for new construction.



Rexall Place. from Wikipedia

Edmonton, the City of Champions, has recently approved the creation of a new hockey arena in the downtown core. This arena is to be built to replace the current venue of Rexall Place, as Rexall is well below current NHL standards and not meeting the needs of the team, the owners or the spectators. While this move is for the betterment of the team and the community as a new development in the downtown core, Northlands (the current operator of Rexall Place) has been asked to sign a non-competition clause with the new arena, which will effectively eliminate Rexall Place as an entertainment venue. Rexall's life is waning, and the question is, will the current home of the Edmonton Oilers be able to adapt to the changing needs and requirements of society or, will it follow in the footsteps of many other arenas that have closed their doors and meet the wrecking ball?



Statue of Wayne Gretzky with Stanley Cup: Front Entrance, Rexall Place. from The Edmontonian

Rexall Place was built in 1974, and at that time was named Northlands Coliseum. Since that time the buildings name has been changed to Edmonton Coliseum, Skyreach Center and finally Rexall Place; however, the building and its hockey history have remained the same. It has been the home of the Edmonton Oilers since they joined the National Hockey League (NHL) in 1979. Since then, it has been the home of 6 NHL Hall of Fame Players and the NHL Championship trophy, the Stanley Cup, 5 times. In addition to being the home of the Edmonton Oilers, Rexall Place frequently plays host to many high profile musical concerts and other sporting events such as the Canadian Finals Rodeo. This building resonates in the hearts and minds as an icon of sport in Edmonton and is well known throughout the NHL as well.

Rexall Place is a large concrete building with a building footprint of 2.94 acres. The building sits on a site of 16.5 acres, most of which is reserved for event parking. The embodied energy of this massive concrete structure cannot be ignored when considering the reuse or redevelopment of the site. Rexall Place is located approximately 2 km north of downtown Edmonton and is directly connected to downtown and the greater Edmonton community through the LRT and mass transit systems. Surrounded by communities of low density urban housing, with a lower than average income, the area around Rexall Place has become a void within the City of Edmonton. Through the conversion of Rexall Place, an easily identifiable building within

Edmonton, into a central hub for these communities. Rexall Place has the potential to drive urban regeneration through the creation of public amenity space and much needed quality housing, with a character that could not be provided through new development.

With the building's history, embodied energy, proximity to downtown, connection to Edmonton through public transit, and the need for quality housing in the area, the adaptive reuse of Rexall Place seems to be the more compelling option.

Adaptive Reuse

Working with existing buildings has become an economic and ecological imperative, through which unique architectural solutions, not possible from new construction, can be developed. "Creative adaptation provides pride in our heritage, a link with the past, respect for the aesthetics and craftsmanship of another time, insights into our development, ample creative opportunity for architectural innovation and problem solving, enhancement of the urban fabric, greater security, stability and beauty, while conserving basic materials and meeting modern needs" (Diamonstein 1978, 13). As with many other industrial type buildings, Rexall Place represents a large volume that provides an over-sized space from which we can draw advantages for new uses. Buildings of this type and size can accommodate several functions and this allows a reconstitution of the multiple amenities necessary to successful communities: shops, offices/ housing, and collective

facilities (Robert 1989, 11).

Adaptive reuse is not a new concept but rather a common trend throughout history which allows building to be kept alive by changing their roles, often to uses never conceived of by their original designers. As explained by Cantacuzino it is only since the Second World War that buildings are more commonly being torn down than being reused (Cantacuzino 1989, 8). It was during this period that many people were leaving the city centers and into a life in suburbia, creating a large number of vacant buildings in the downtown cores of cities that were then demolished to make way for more profitable developments such as shopping centers and office buildings. The trend of demolition and new building has led towards the degradation of the urban core and unchecked urban sprawl.

More recently however, there has been a push back to urban sprawl and an increasing desire to relocate back in the city center. This urban regeneration is at the forefront of many architectural discussions in contemporary society. Society is now realizing that it can no longer sustain the urban sprawl that has affected many cities around the world. This sprawl and the creation of suburbs, usually due to lower land costs further away from the downtown core, was originally thought to provide the ideal living conditions of privacy, security and home-ownership. However, this perception is now being found to have a detrimental effect on the cities in which they serve. These suburbs or "Edge Cities" as referred

to by author Joel Garreau have decentralized the job market away from the city center (Katz 1994, xii). As well there is an increasing sense of displacement between the people living in the suburbs and the cities in which they live. This can be seen through the increases in pollution, crime, congestion and the feelings of isolation one has from their surroundings. As such the current trend towards urban regeneration suggests that many individuals are looking to move closer to work, make new contacts and create a new lifestyle. With the societal trend to move back into the city the question then becomes how do we stimulate growth and create affordable housing downtown?

According to Peter Calthorpe in *The New Urbanism*, infill provides the best opportunities to utilize urban infrastructure and maintain quality green space within the city (Katz 1994, xiii). This type of construction takes advantage of the unused space that is in or near the city center. However, this type of project can be difficult to accomplish as community action groups may resist development in their neighbourhoods. Another roadblock to infill is the cost of the land. High land costs translate into higher rents and mortgages that make living downtown less appealing. As well, the amount of construction that can be created by infill is not sufficient for the number of people that wish to return to the city. In this case we need to find alternatives to infill that can also allow people to move back into the city. As suggested by Diniawarie in *Urban Living*, the solution should be through the repurposing of unused office buildings in the downtown area. Such buildings

have allowed a shift in the emphasis of restoration to a freer and more creative attitude towards reuse that takes into account each buildings economic, social, and ecological value towards the issue of urban regeneration (Cantacuzino 1989, 9). The studies Diniawarie refers to have been conducted in Germany where nearly 11% of available office space was vacant and unused. By converting these office buildings into residential housing we are able to accomplish many things at once. We are able to keep the cost of construction down as the building already exists, we are providing income to the building owner, and we are generating housing for people to move back into the city center. This type of conversion is further supported by a statement by Dr. P.A. Stone from 1971 in which he writes, "urban quality depends more on the standard of maintenance and improvement of existing stock than on the standards of which new stock is built" (Cantacuzino 1989, 11). The conversion of existing buildings also allows the new residents to typically take advantage of existing amenities such as public transport, shopping, restaurants, schools and other infrastructure typically within walking distance of the converted buildings.

While converting these buildings and reshaping the downtown core into a space that is available for the general public to find housing is a major step to enable urbanism, it may not be enough to attract individuals to move to a specific location. In today's society where everything is mobile and interconnected it is even more important to create a

quality of life that brings people to the city. Richard Florida suggests this occurrence in his book *Cities and the Creative Class* where he states that a region's ability to attract talent (people), largely depends on the quality of place. He suggests that talented people are highly mobile and that it is important to provide a range of lifestyle amenities to attract them and find ways to keep them. The research shows that a higher number of individuals are attracted to cultural amenities such as museums and galleries than to recreational amenities and climate (Florida 2005, 99). However, he does clarify that when discussing recreational amenities, people are more attracted to outdoor activities than to major spectator sports. Therefore, it is to be assumed that given cultural amenities and a high level of access to outdoor recreational activities, a city can start to attract a number of quality people and help to revitalize its urban core.

Sport Facilities

“Sport is a phenomenon that is strongly related to the social and cultural contexts in which we live” (Joubert 2008, 32). Historically many sport facilities have been used to stimulate urban regeneration. While a venue is first and foremost for the spectacle or event, it also provides a city the opportunity to address key issues such as infrastructure, expansion and restoration to name a few. Most notably these issues are addressed as part of a cities bid and preparation for major world sporting events such as the Commonwealth Games, the Pan-Am Games,

and the Olympic Games.

While it is important to understand that sport led urban regeneration can occur at many levels, from a single arena to a major event with many facilities, the effects of this type of urban regeneration is best documented at the Olympic level. Adrian Pitts shows that Olympic led restoration has taken on different roles at different periods of Olympic history. In the 1950's this was combined with the need for post-war restoration, the 1960's and 70's supported urban expansion while the 80's and 90's were about inner city restoration (Pitts 2009, 29). Each of the Olympic Games has been used by the host city to identify and correct issues within the city. However, while these approaches were appropriate for the time, many of the venues constructed have not been able to adapt to the changing need of the city. Of particular interest is the 1976 Olympics of Montreal, in which many of the building interventions and construction for the games have found difficulty in sustaining their original functions, including the Olympic Stadium which has not had a main tenant since 2004 and the Mirabel airport, which was closed in 2004.

A study of current sport venues may help to illuminate the reasons why some stadiums are more successful than others. The trend of the sole purpose building, as seen from the Montreal Olympics, can no longer provide a viable option for the design and construction of sports venues. This type of venue is only active on event days and remains lifeless during the period between events. In today's social and economic



Richmond Oval during and after Games. from The Seattle Times

climate this is no longer possible. These building types, in order to be viable, need to offer a wide range of non-sporting activities including but not limited to shopping, restaurants and cinemas. These auxiliary facilities are integral to the validity of sport led urban regeneration as they help to create a building type that is productive and viable at all times of the day and year. As well by including these other facilities within the building we are able to appeal to many groups that may have originally been opposed to this type of construction such as local residents and authorities and get them to invest in it. By appealing to the community, the retail and commercial aspects of the venue will be able to sustain the building on non-game days. The increased activity in this new development will in turn help to improve the local communities and strengthen the municipality overall. A building which served a wide spread, narrowly focussed constituency at a cost to the quality of the local community, can become a resource and locus of revitalization to the local community through adaptive reuse.

As Sheard suggests sport architecture can no longer be isolated from their surroundings (Sheard 2001, 212). Today's sport stadiums are now integrating into the city fabric, typically within the existing city grid, which helps provide the necessary conditions for urban renewal and growth. This is evident through examples such as Baltimore's Oriole Park and Cleveland's Progressive Field. Both of these projects fit the stadium within the existing city grid. By doing this, the stadium or sporting venue is able



Highbury Square, Arsenal. from Arsenal.com

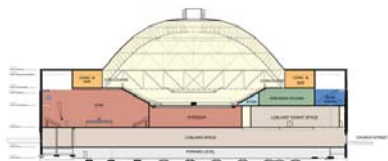

Revised Section of Maple Leaf Gardens. from blogTO

to connect to the existing infrastructure easily, while being within a short walking distance from housing and shopping. This also allows the sporting venue to add to, and take advantage of, the local diversity within the area.

It is important to think about these facilities and their current purpose, however, we also need to think about how they will act when there is no longer a need for them to function as sporting venues. Many architects have started to think this way and have started designing their building in such a manner that they are adaptable to post Games use. Usually these facilities are in related to Olympic architecture where the buildings and stadia are required to host specific events for a 2 week time period. As Jodidio suggests in *Public Architecture Now*, these architects are starting to take into account the post-event life of these buildings and how, in many ways, this is even more important than the initial purpose of the building (Jodidio 2010, 15). Other such examples consist of the adaptive reuse of existing sport facilities into other building types. Most notably is the recent redevelopment of Highbury Square in Arsenal. This project has taken the existing 93 year old European football stadium and converted it into over 650 apartments with a central garden located over the former pitch. In Canada similar projects are taking place as currently the former Maple Leaf Gardens in Toronto is being converted into a multi-use facility shared by Loblaws and Ryerson University.

While the examples of Highbury Square and Maple

Leaf Gardens are very different in their overall program, there are similarities in the approach to the re-use of the existing buildings. Both projects have identified key elements that are integral to the identity of the building and have treated these elements with special care. For Highbury Square the overall project has maintained the existing pitch and converted this area into a public garden area while the new residents of the building reside in apartments constructed where the stands once stood. The Maple Leaf Gardens has been converted into a grocery store, parkade and the new Ryerson University athletic center. The key elements that have been identified by the architects are the domed roof and the ice surface of the building. While the original ice surface was removed, it was moved up to the fourth floor of the building allowing for the other programmatic elements to occur. By moving the ice surface up, the architects have also been able to maintain and keep the roof structure and the relationship of ice to roof.

Adaptive reuse projects offer many opportunities to the architect. While Culley suggests that these types of projects require special consideration and creative engineering to bring them up to current financial and environmental standards, this type of building intervention can extend the life of a building or even enhance what is already there (Culley 2009, 235). Adaptive reuse requires the architect think differently about the space and determine what functions the building form will accept, providing the architect with a different design problem capable of

a number of variable outcomes, most that would not be conceived of, or possible with new construction.

CHAPTER 2: DESIGN

Site Analysis

Rexall Place, formerly Northlands Coliseum, was built in 1974. In addition to becoming the new home of the then World Hockey League Edmonton Oilers, the construction of the Coliseum helped Edmonton secure a bid for the 1978 Commonwealth Games. This successful bid saw Northlands Coliseum host the gymnastics events from those games. In addition, this facility has been a part of other major sporting events such as the 1983 Universiade Games, and the World Junior Hockey Championships in 1995 and 2011. Rexall Place is part of a larger sport and entertainment complex, Edmonton Northlands, but is separated from the rest of the Northlands grounds by 118 Avenue. As such, the site surrounding Rexall Place has seen numerous changes to accommodate the growing demands of Edmonton Northlands, which was established in 1910 just north of downtown Edmonton. The Rexall site is a triangular section of land created by the intersections of 118 Avenue and Wayne Gretzky Drive and an above ground portion of the City's Light Rail Transit (LRT) system. The area of Edmonton Northlands is surrounded by communities with the majority of residences being in the form of apartments or condominiums in low rise buildings with fewer than 5 stories. These communities were typically built after the Second World War and exhibit a significant transient trend in which a low number of the households have been living at their current address for more than five years



Rexall Place and Northlands in relation to Downtown. from Northlands



Rexall Place Site Boundaries. from Google Maps

while the majority of inhabitants are renters rather than homeowners. In addition the average income is significantly lower in these communities than the rest of Edmonton at large. This transient trend coupled with lower than average income suggests that the east end of Edmonton is a non desirable area for the residents of Edmonton. By providing quality housing and amenities in central location to these communities, we can help bring people to the area and reform the east end of Edmonton as a more desirable location. With the Edmonton Oilers moving to a new facility, the adaptive reuse of Rexall Place seems to provide the perfect opportunity to provide a kick start to urban regeneration within all of the surrounding communities.

Through a study of aerial photographs over the past 80 years, it is possible to see the overall impact that Northlands has had on the surrounding communities. As Northlands has grown, parts of the surrounding communities were appropriated to provide more parking for the sport and entertainment venue. With this also came an increase in the traffic density to the point where Wayne Gretzky Drive has created a number of dead end streets in the neighbouring community of Bellevue. The growth of Northlands can be seen as an integral factor in shaping the surrounding communities to what they are today. As well due to the large amount of parking that is provided, Rexall is surrounded by a sea of asphalt which leaves the building devoid of life between events.



Edmonton Northlands - 1924
from Edmonton Archives

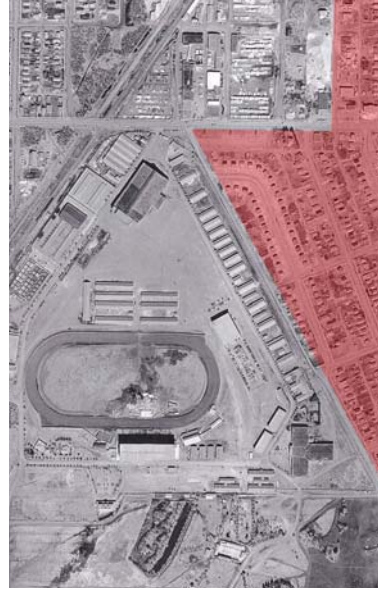

Edmonton Northlands - 1954
Development of Bellevue community to east
complete. from Edmonton Archives



Edmonton Northlands - 1974
Northlands Coliseum in progress; Wayne
Gretzky Drive is built creating a separation
between parts of the Bellevue community
with one main road connecting the parts. from
Edmonton Archives



Edmonton Northlands - 1993
Northlands expropriates part of separated
Bellevue community; final connecting road
between community is removed; 118 Avenue is
now major road. from Edmonton Archives



Edmonton Northlands - 2011

Northlands expropriates remainder of Bellevue community west of Wayne Gretzky Drive; Wayne Gretzky Drive is connected to Yellowhead Trail to the north with overpasses. from Google Maps

While Rexall is located close to the river valley park system the immediate surroundings are relatively devoid of recreational park space. There are a few parks with programmed recreational space such as soccer fields, and playgrounds scattered throughout the surrounding communities, most of which are located at schools or community leagues, however closer to Rexall there is very little park space at all. As well the park space that is closest to Rexall is simply an open space with no programmed elements providing little benefit to the neighbourhood.

The areas surrounding Rexall Place are largely low density residential housing with a few larger pockets of commercial throughout. Typically the commercial is off of the main corridor of 118 avenue in the form of strip malls or commercial buildings. While this is a commercial corridor, there is little in terms of quality retail for the residents around Rexall. The commercial/ retail makeup of the corridor consists of a number of small businesses, gas stations, car dealerships, auto repair shops, restaurants and hotels. This commercial corridor is also intermixed with the residential housing within the communities of Montrose and Bellevue until it reaches Wayne Gretzky Drive at which point the commercial corridor takes control along the remainder of 118 avenue west of Rexall Place.

Program

Adaptive reuse projects provide an opportunity that may not be available in a new build project. For the reuse of such a building as Rexall Place it will

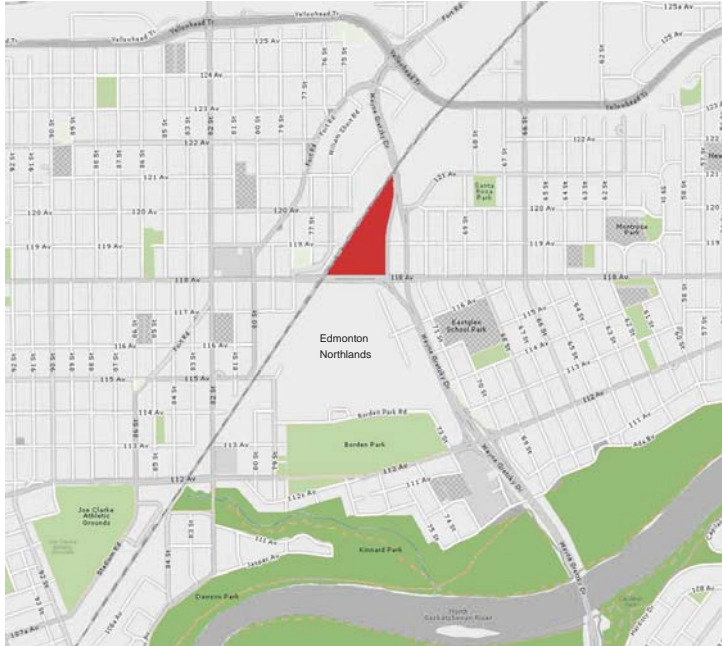

East Edmonton Green Space. from City of Edmonton

Legend

- River Valley
- Recreational Amenity
- Unprogrammed Park



Typical Conditions Near Rexall Place. from City of Edmonton

Legend

- Industrial
- Residential
- Schools
- Commercial



Typical Residential street. from Google Maps



Typical Schools. from Google Maps



Typical Commercial along 118 Avenue. from Google Maps

be important to maintain the building as identifiable within the Edmonton community. In this project the spirit of Rexall Place will be maintained through the retention of the some of the structural systems such as the roof trusses, the overall shape of the building and the exterior cladding of the building.

The proposed program for the reuse of Rexall Place is a combination of residential, commercial and athletic/ recreational facilities, similar in composition to an Olympic Athletes' Village. In order to ensure the economic viability of the project there will need to be the inclusion of a number of amenities to help draw the public in and make this building active at all times.

By providing a range of interior and exterior public amenities the project will be able to take full advantage of the entire site. Exterior amenities would include a new green space with recreational facilities such as a soccer field and outdoor hockey rink, while the interior would include commercial/ retail space and recreational facilities, including changing facilities, a gym, yoga/ dance studio space, and physiotherapy. Private residential units will occupy the upper floors of the building.

With the proximity to public transit and major roadways, Rexall Place has the potential to give back to the communities by becoming a central hub and destination for the public throughout the local communities and greater Edmonton at all times of the day and year.

Site Strategy

The site strategy for Rexall Place is to remove most of the above ground parking, provide a much needed green space for the surrounding communities and reinforce the connection between the LRT and Rexall Place. This green space will include a full sized soccer field and outdoor hockey rink. A number of trees will be planted along the LRT fence line to provide a visual screen for the LRT as well as a wind barrier for the users of the outdoor space, as the predominant winds in Edmonton come from the northwest. A small public parking lot on grade at the corner of Wayne Gretzky Drive and 118 avenue will be retained as the only public parking for the site. This should encourage users of the facilities to make use of the extensive public transit located directly off site.

Rexall Place is situated right along the LRT system, next to a major transit station, is on a major North/ South axis in the city (Wayne Gretzky Drive) and is very close to the Yellowhead Trail (one of Edmonton's major East/ West thoroughfares). With the existing infrastructure surrounding Rexall Place as well as its potential connection to the river valley, Rexall is well situated to act as a hub for the surrounding communities.

While part of the program entails recreational facilities it is also important to consider what the rest of Edmonton has to offer, in particular directly accessible from the LRT. This mode of travel provides the quickest and most direct line of travel between



- Keynotes
- 1. Rexall Place
 - 2. Soccer Field
 - 3. Hockey Rink
 - 4. LRT Entrance
 - 5. Tree line
 - 6. Public Parking
 - 7. Parkade Entrance

Rexall Place Site Plan

Rexall Place and the rest of Edmonton. The LRT also connects Rexall Place with 2 of Edmonton's major post secondary institutions and directly with the downtown core making access to work a very easy commute for most people.

Building Design

The existing building has been modified substantially from the original plans. The main floor of the building (main concourse) has been filled, removing the lower bowl out of the design. The mezzanine level (level 2) has been removed and ice level (level 1) has been converted into underground parking and storage for the residents of the building. Access to this parking level remains the same with the vehicular access ramp coming off of Wayne Gretzky Drive.

Above grade the building design consists of four components:

1. Public Amenity Space
2. Commercial Space
3. Recreational Space
4. Private Residences

The main floor (existing level 3) has been converted into the public and recreational facilities. The center of the building, which has now been raised to meet the existing floor plate, has been converted into a large public garden space with meandering paths, a water feature, grass and trees.

The south side of the main floor will consist of the more commercial/ retail program of the building as this is next to the entrance to the LRT and connected to the public parking area. Included with these amenities will be a preschool/ daycare and indoor playground for parents to take their children to on their way to work. These will be along the interior ring opening up to the central courtyard, allowing these programmatic elements to take full advantage of the enclosed garden space. As the building extends north the program will shift to the recreational spaces such as the gym, yoga/ dance studios, public change rooms and physiotherapy center. The gym and studios will face onto the interior courtyard providing light to the space and placing these activities on display for the people using the courtyard. A number of team dressing rooms have been located along the outer wall on the north east side of the building to allow for teams and public better access to facilities while using the outdoor recreational amenities.

Above the main floor the existing floor plates have been either cut back or extended to accommodate the revised program of residential units. The new second and third floor (existing levels 4 and 5) now consist of an interior ring of one bedroom units and an exterior ring of 2 bedroom units. The new fourth floor (existing level 6) has been converted into an interior ring of 2 bedroom penthouse suites while the exterior ring consists of 4 bedroom penthouse units. Above the penthouse units, occupying the trusses is a private garden and walking/ observation space for the residents of the building to enjoy.

Keynotes

- 1. Landscaped Courtyard
- 2. Commercial/ Retail Units
- 3. Gym
- 4. Yoga/ Dance Studios (Flexible Space)
- 5. Physiotherapy
- 6. Team Change Rooms
- 7. Public Change Room
- 8. Recreation Facilities Office
- 9. Preschool/ Daycare
- 10. Indoor Playground
- 11. Special Events Room
- 12. Building Services
- 13. Soccer Field
- 14. Hockey Rink

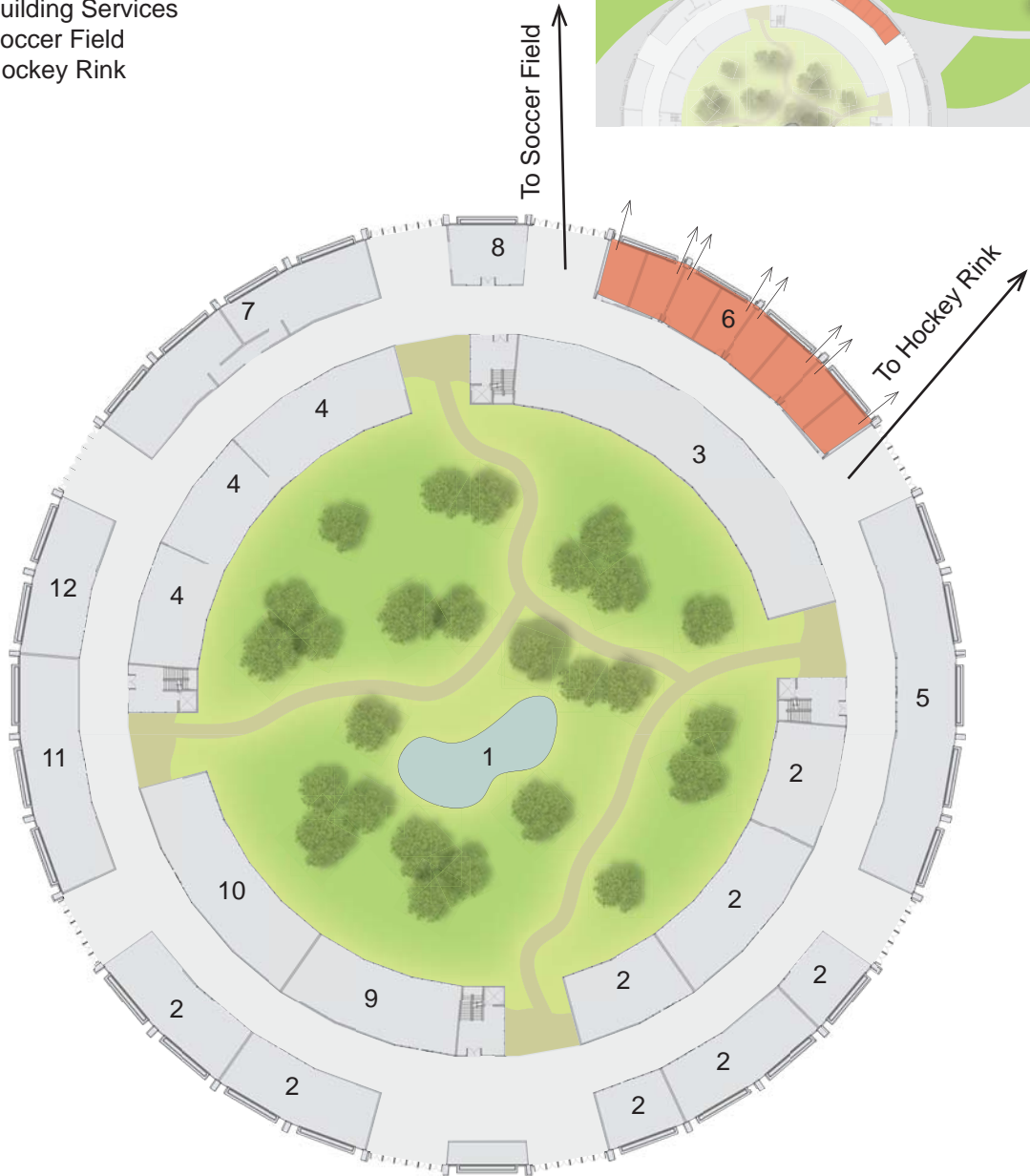
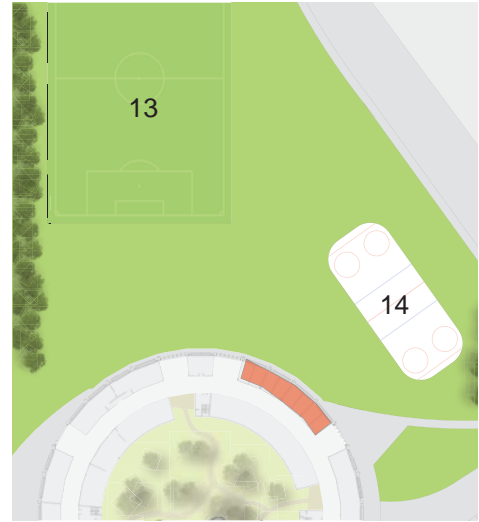

Main Floor Plan

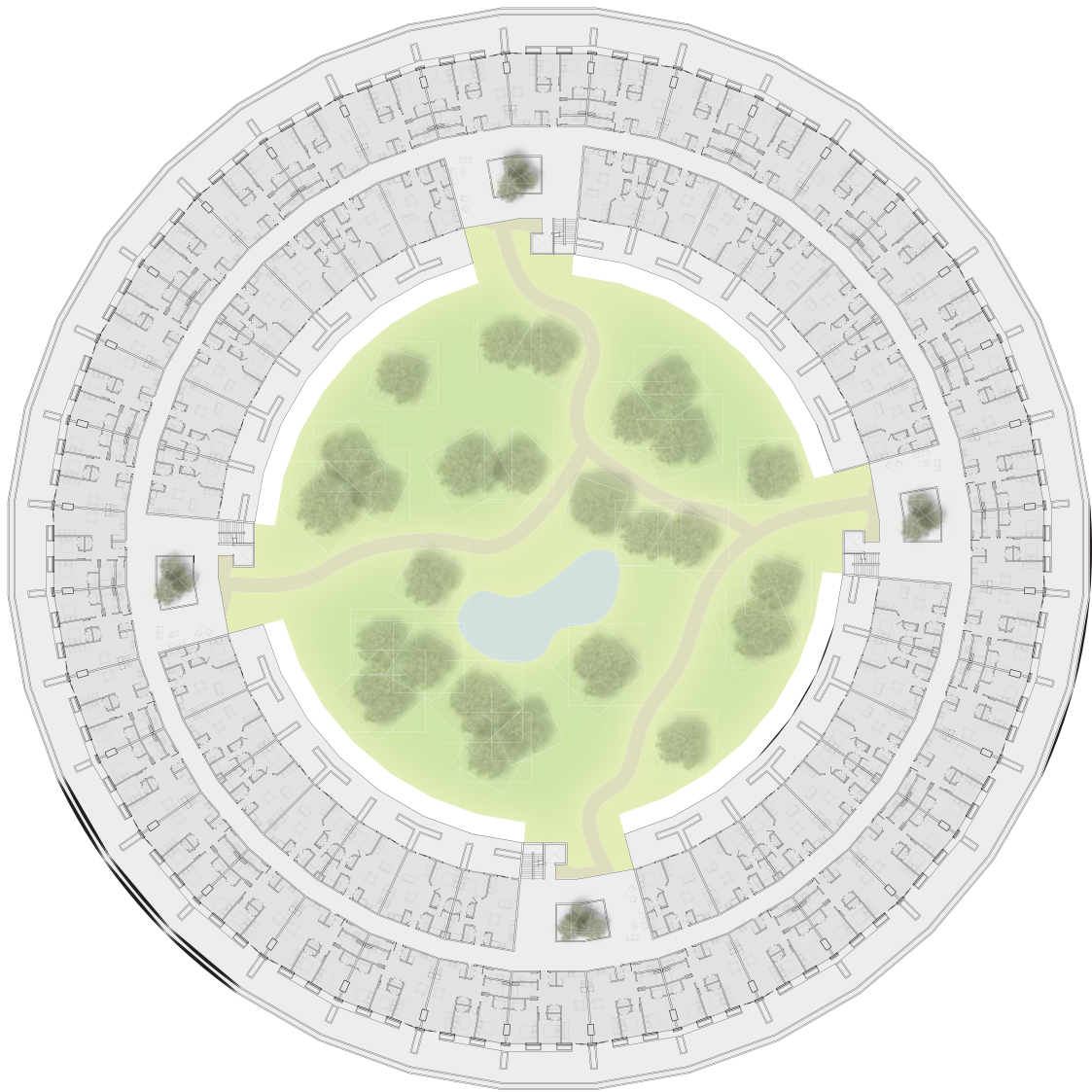

Second and Third Floor Plan

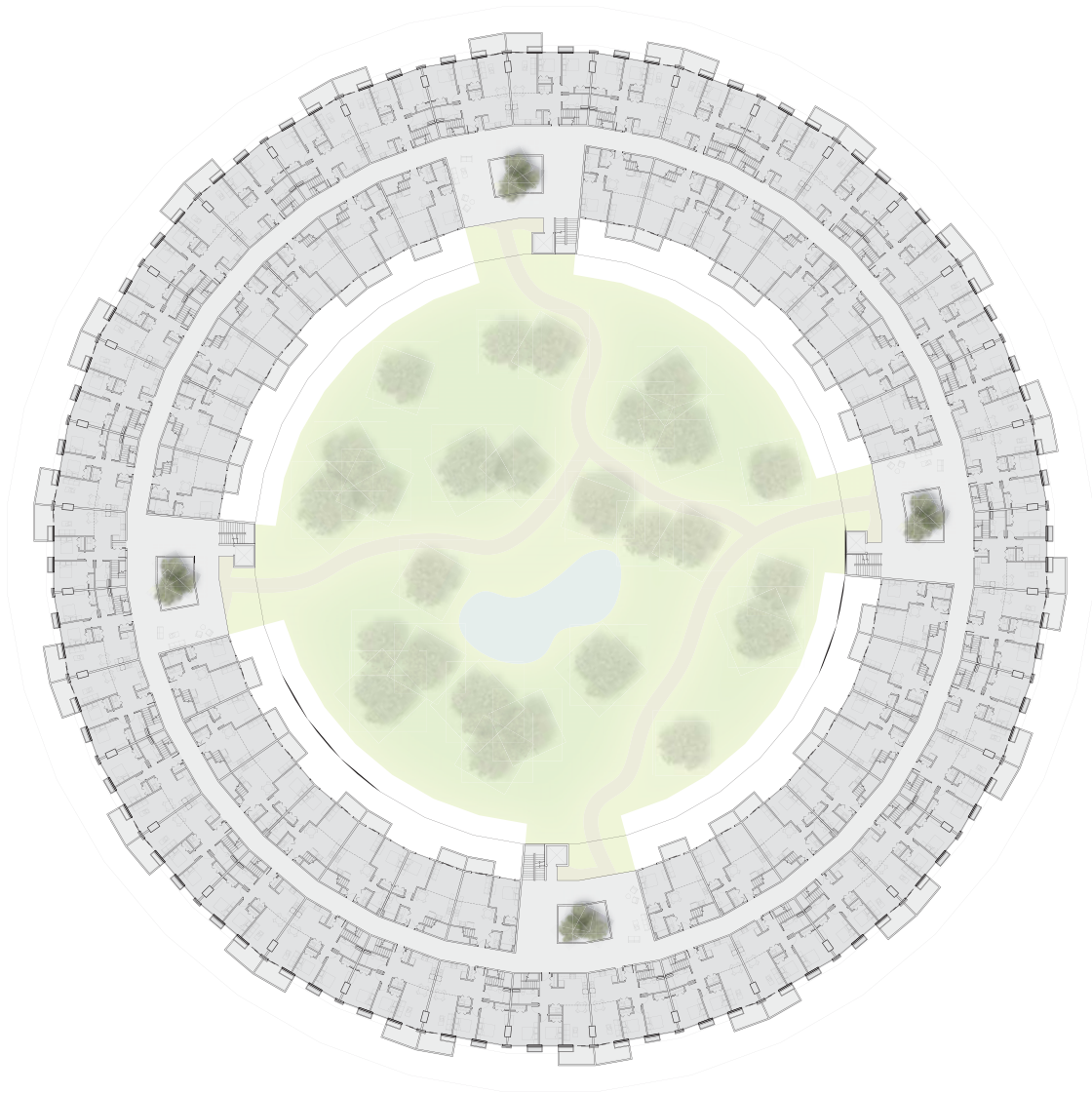





Fourth Floor Plan

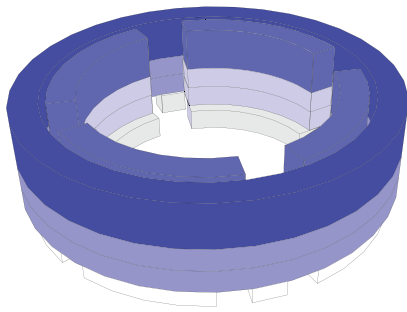

Building Section



Unit Assembly Diagram

-  Commercial/ Retail
-  Recreational
-  One Bedroom
-  Two Bedroom
-  Two Bedroom Penthouse
-  Four Bedroom Penthouse

Unit Keynotes

- 1 Entry
- 2 Laundry
- 3 Washroom
- 4 Kitchen
- 5 Dining
- 6 Living
- 7 Bedroom
- 8 Walk-in Closet
- 9 Den/ Office
- 10 Open to below
- 11 Patio

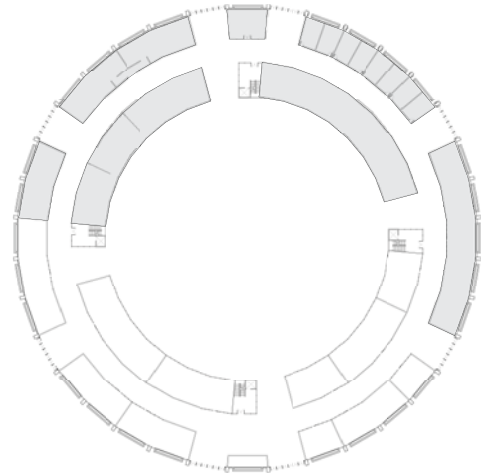

Main Floor

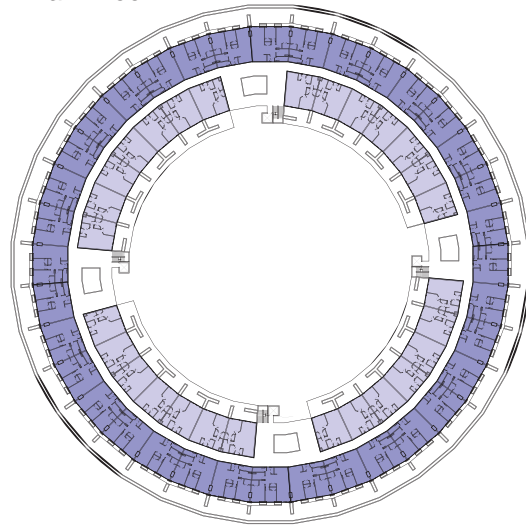

Second and Third Floor

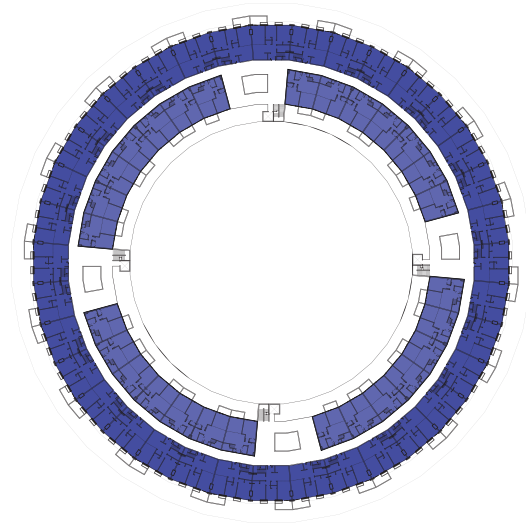

Fourth Floor

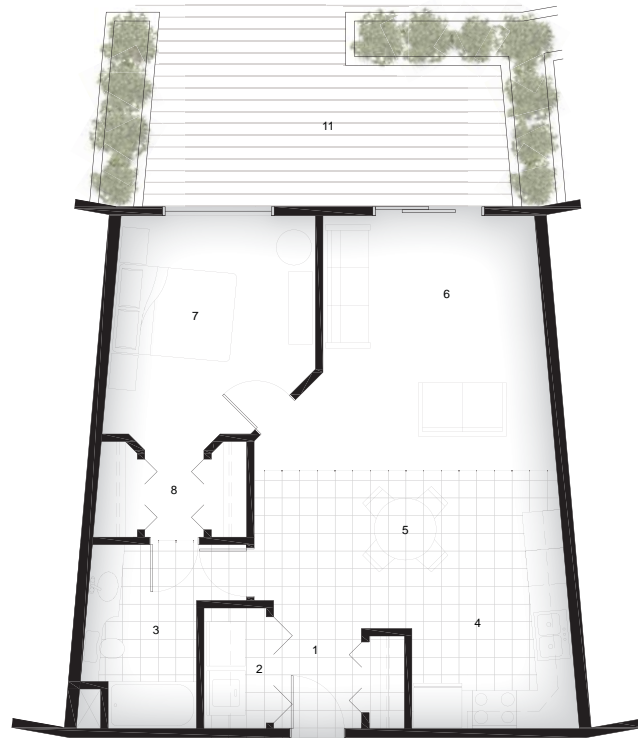

One Bedroom Unit

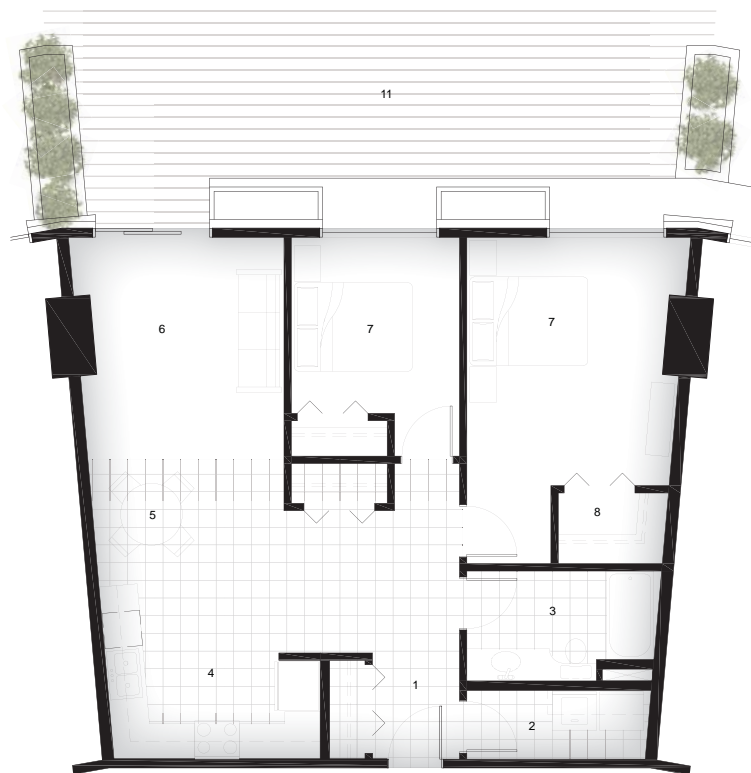

Two Bedroom Unit

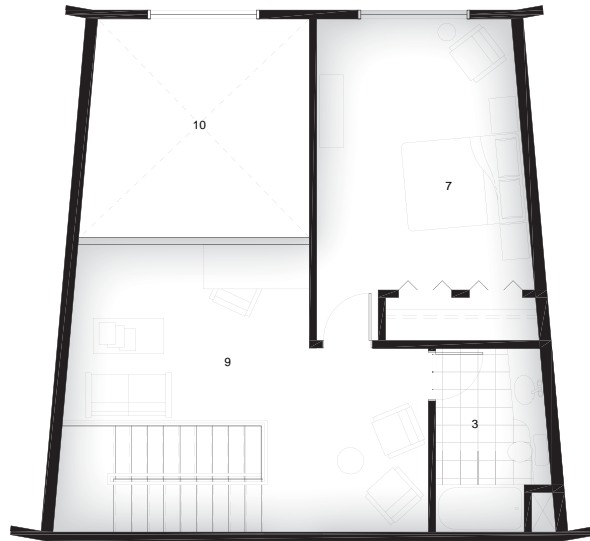

Two Bedroom Penthouse - Upper Floor

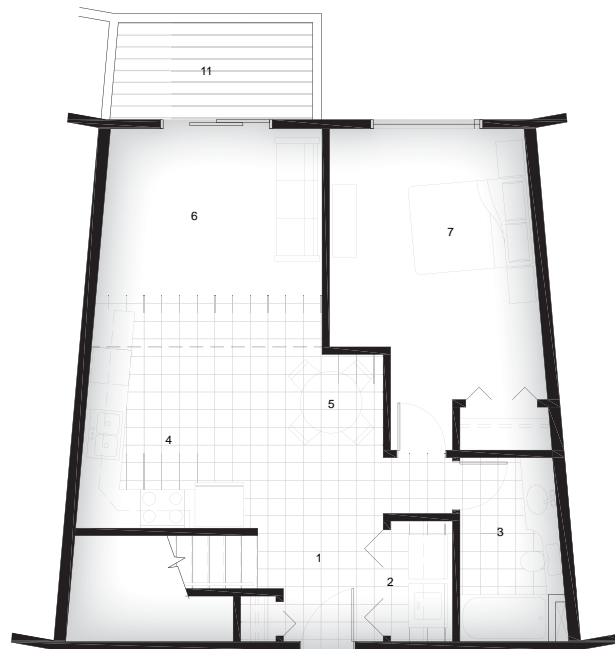

Two Bedroom Penthouse - Lower Floor

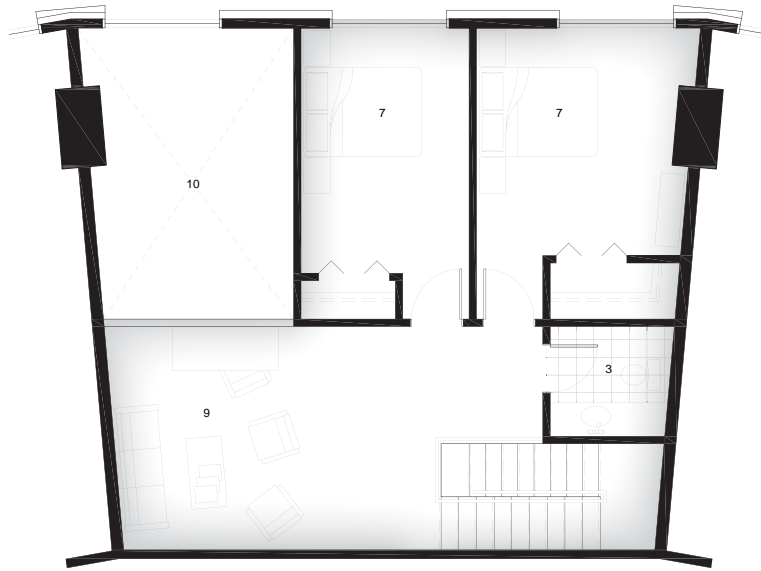

Four Bedroom Penthouse - Upper Floor

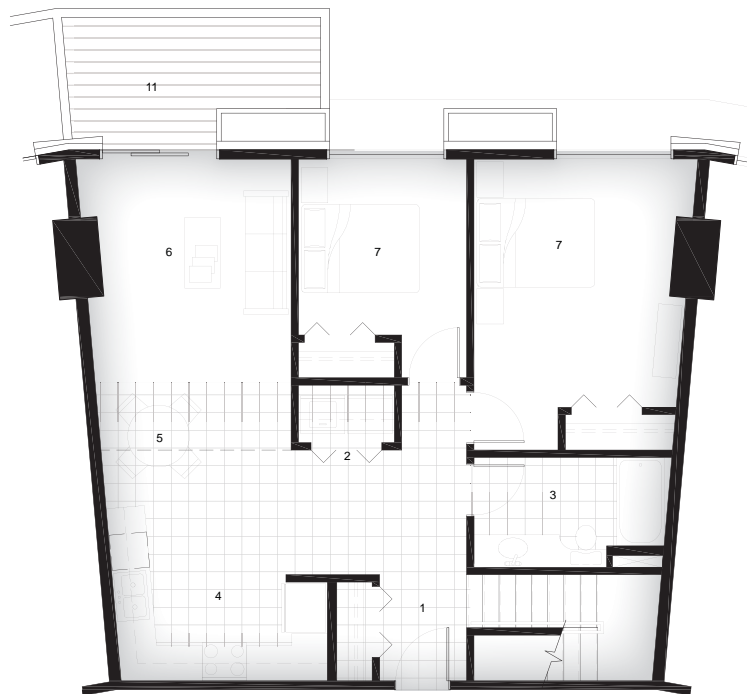

Four Bedroom Penthouse - Lower Floor

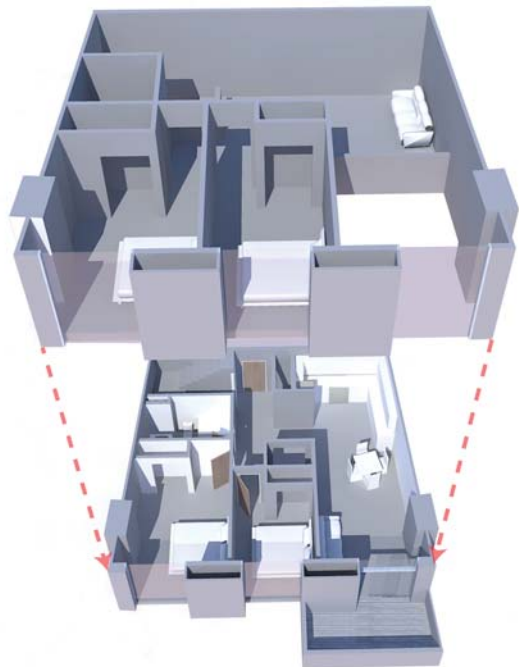
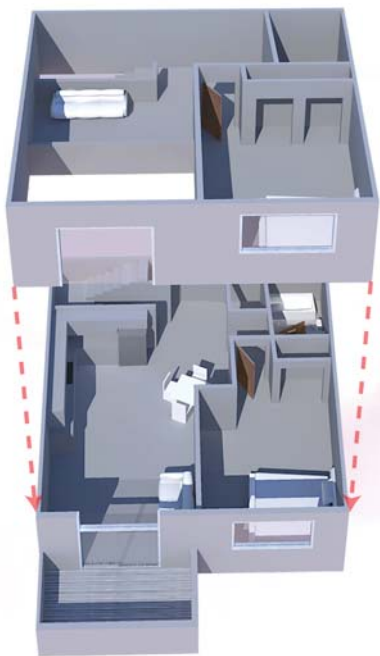
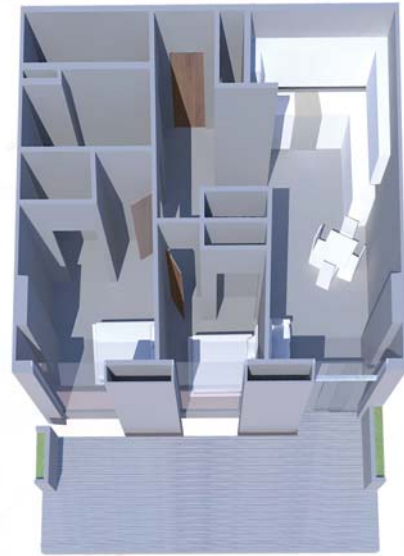

Unit Axonometric Drawings

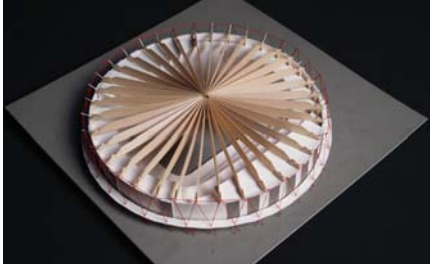

Tension Ring Model

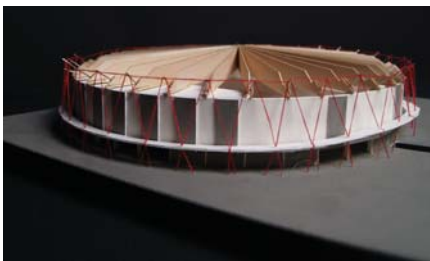

Tension Ring Model

To allow daylight into the building I have employed two strategies. For the exterior of the building I have removed every second precast panel along the exterior of the building and replaced this with full height glazing, while for the interior I have removed the roof cladding and left the existing trusses exposed. By doing this we are able to provide natural daylighting to the interior courtyard and residential units, provide natural ventilation to the interior of the building and remove the need to provide irrigation to the vegetation in the courtyard.

The final design decision was to break through the exterior facade of the building by providing balconies on the third and fourth floor and a suspended ring around the second floor. This ring runs around the entire building and serves as a walking track and the balcony space for the residents of the second floor. The track is suspended through a series of trusses added to the exterior of the building. These trusses are attached to the existing truss system via a pin connection and held in place through the use of a tension ring. The intent was to push the program outside of the building while strengthening the illusion of a light and air structure. To help achieve this, the tension members extend beyond the track and tie into the ground, adding to the illusion that the structure is going to float away.

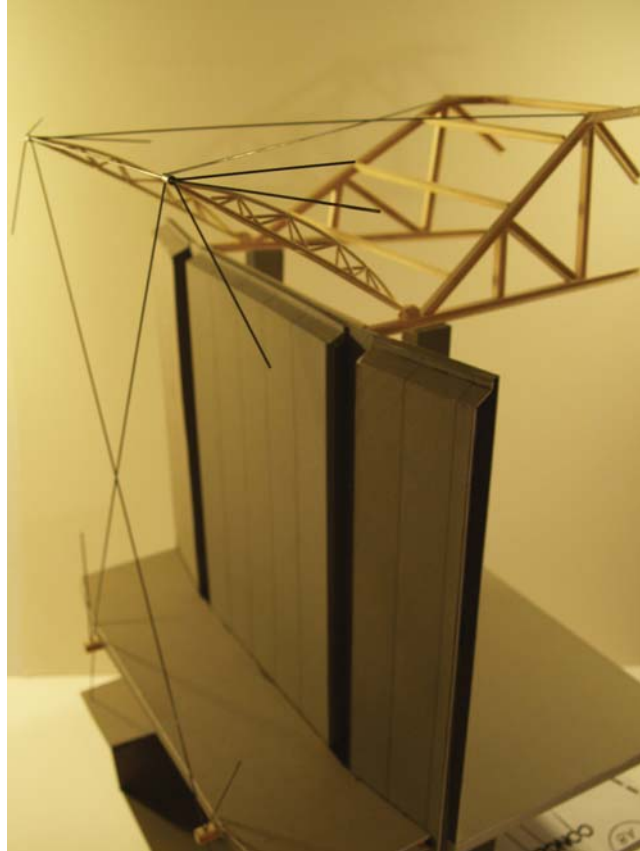

Model Showing the suspended walking track and new structural system



Close up of new structural system



View from pedestrian walkway, LRT entrance



Exterior balconies and walking track

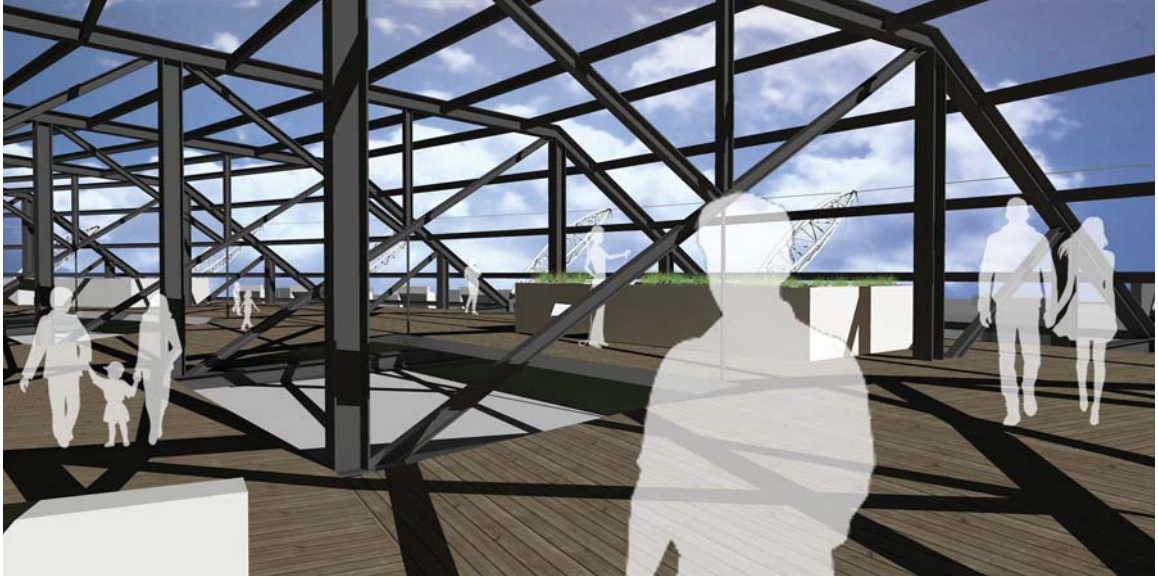

Truss space looking out towards City of Edmonton

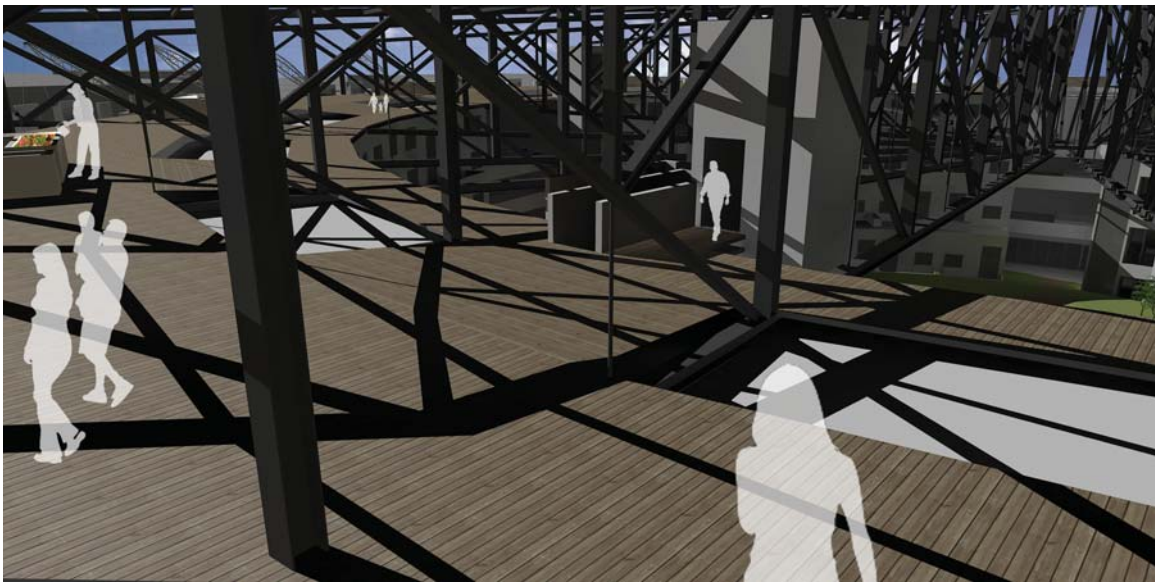

Truss space looking in towards courtyard



Interior courtyard

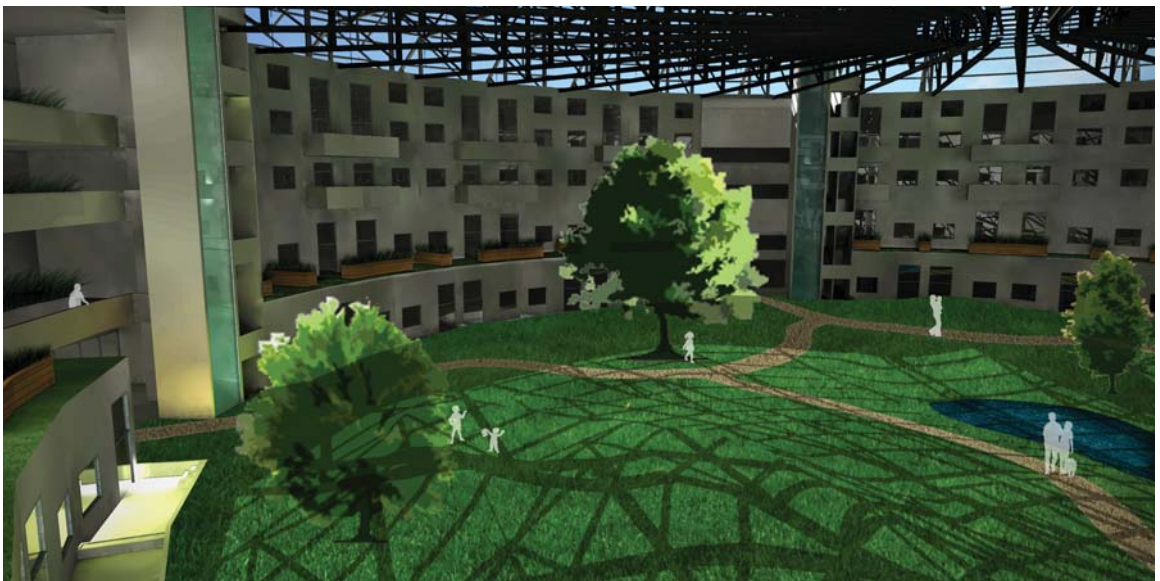

Interior courtyard



Interior balcony conditions

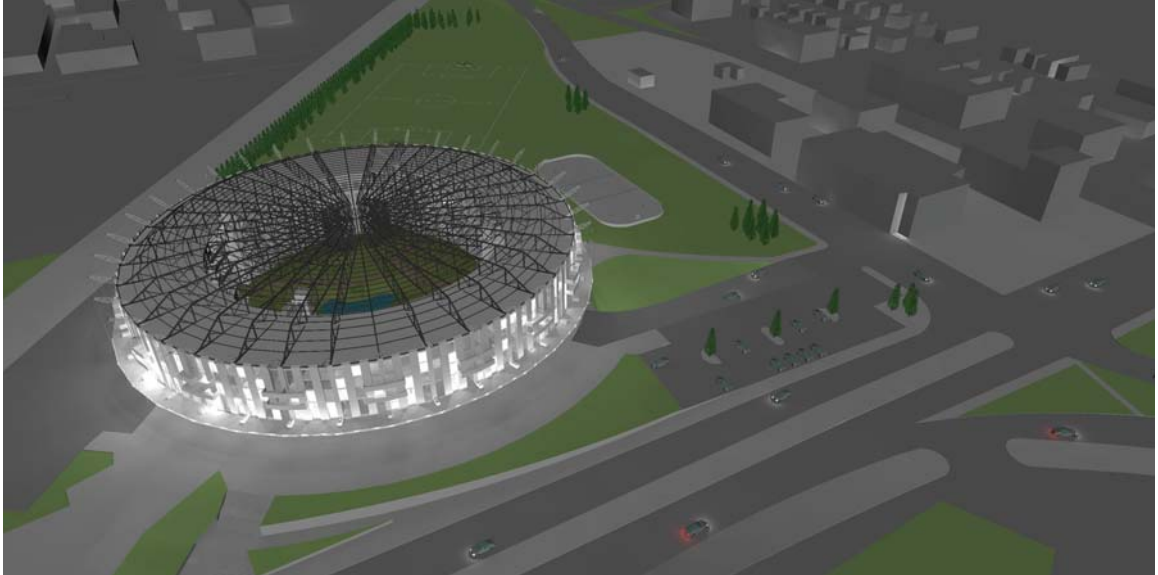

Exterior of Rexall Place at night

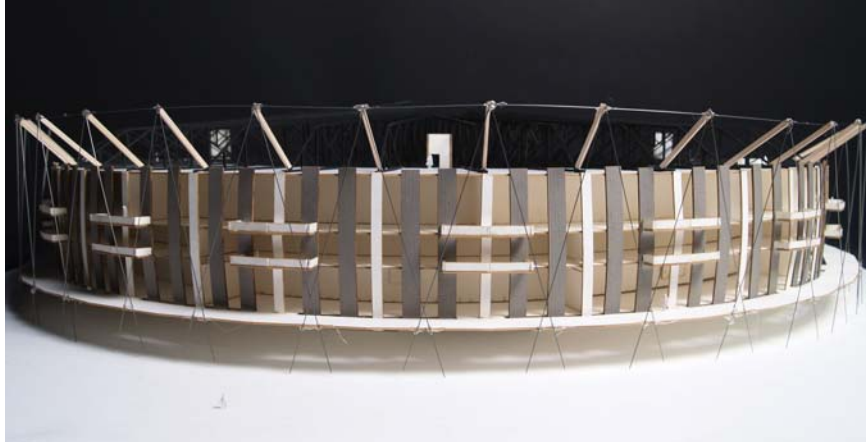

Model showing exterior facade condition



Model showing interior courtyard condition



Model showing interior balcony condition



Model showing interior courtyard condition

CHAPTER 3: CONCLUSION

The focus of this thesis has been to explore the potential of adaptive reuse of large scale sport and entertainment venues. While specifically dealing with Rexall Place, it cannot be ignored that there are many similar buildings in other cities around North America and the world. With this in mind it has become clear that each venue, while similar in initial program may have a wide variety of responses, making each project a special case.

Through the design process I have discovered that there is no one correct answer to the potential program for the reuse of such a building. However, the adaptive reuse this building type needs to be justified to the city and potential developers as well as the local communities so that everyone can buy into the project to help make it a success.

Design decisions were based on factors such as depth of plan, circulation, natural daylighting and ventilation and a number of external factors as well. These included the existing residential housing stock around Rexall Place, the commercial and recreational facilities around the site and the proximity to mass public transit.

Rexall Place is located directly along Edmonton's LRT system and is therefore quickly connected to downtown, post secondary institutions, and extensions to both the north and south ends of Edmonton. With this in mind it is important to include a range of public amenities to the building

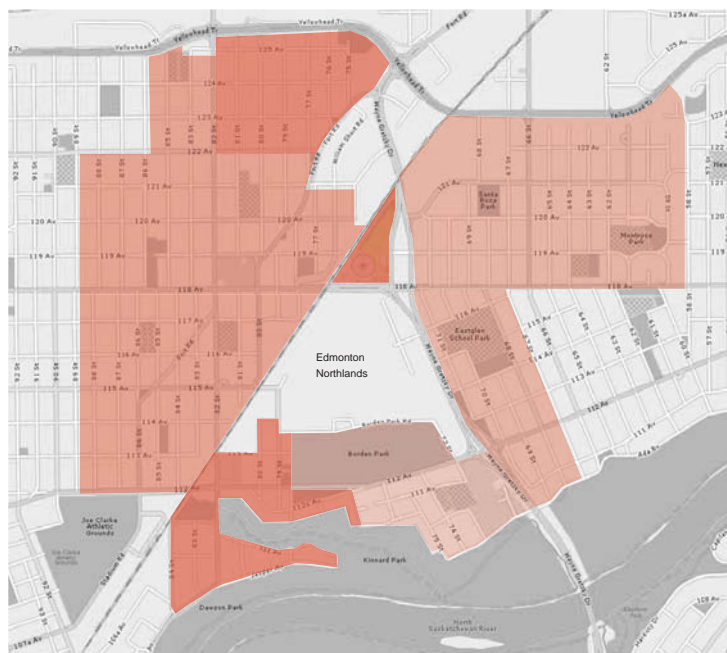

Legend

- 24 people/ acre (Rexall)
- 22 people/ acre
- 15 people/ acre
- 9 people/ acre
- 6 people/ acre

East Edmonton Population Density. from City of Edmonton

to accommodate the pedestrian traffic that would be inherent from having a transit station nearby. The inclusion of public amenities along with a range of much needed green space and recreational facilities within the building we are able to reshape Rexall Place into a community hub with which all of the surrounding communities can be a part of.

To further the argument that this intervention is viable for Rexall place we also need to consider the development side of the project. With the current design Rexall Place has 56 one bedroom units, 100 two bedroom units and 36 four bedroom units. With this unit distribution Rexall Place can house approximately 400 people on a site of 16.5 acres. This translates into a population density of 24 people/ acre, whereas the surrounding communities have a population density ranging from 6 people/ acre to 22 people/ acre. This suggests that the redevelopment of Rexall Place is consistent with the current housing trends in East Edmonton.

Can adaptive reuse provide an architectural alternative to the wrecking ball for large scale sports stadiums?

I feel that the conclusion that I have come to is that in the case of Rexall Place there is a good argument supporting the reuse of the building over demolition. As for other similar projects, each case is situational with pros and cons for both reuse or redevelopment.

APPENDIX: EXISTING SITE AND BUILDING CONDITIONS



Existing site conditions

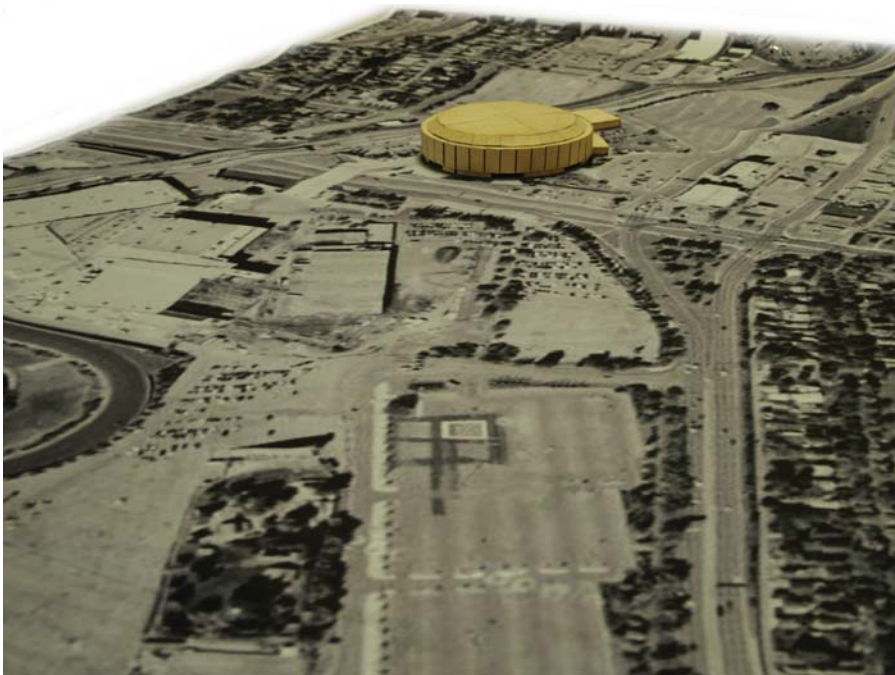

Existing site in relation to Edmonton Northlands

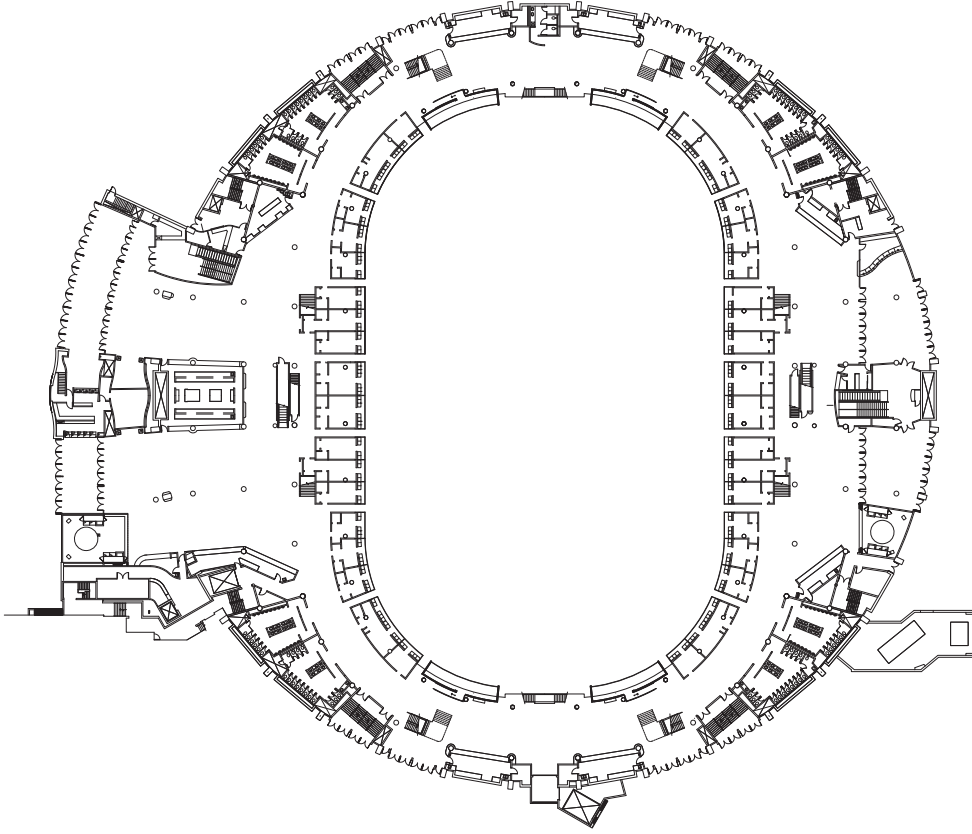

Rexall Place - Existing Level Three Floor Plan. from Edmonton Northlands

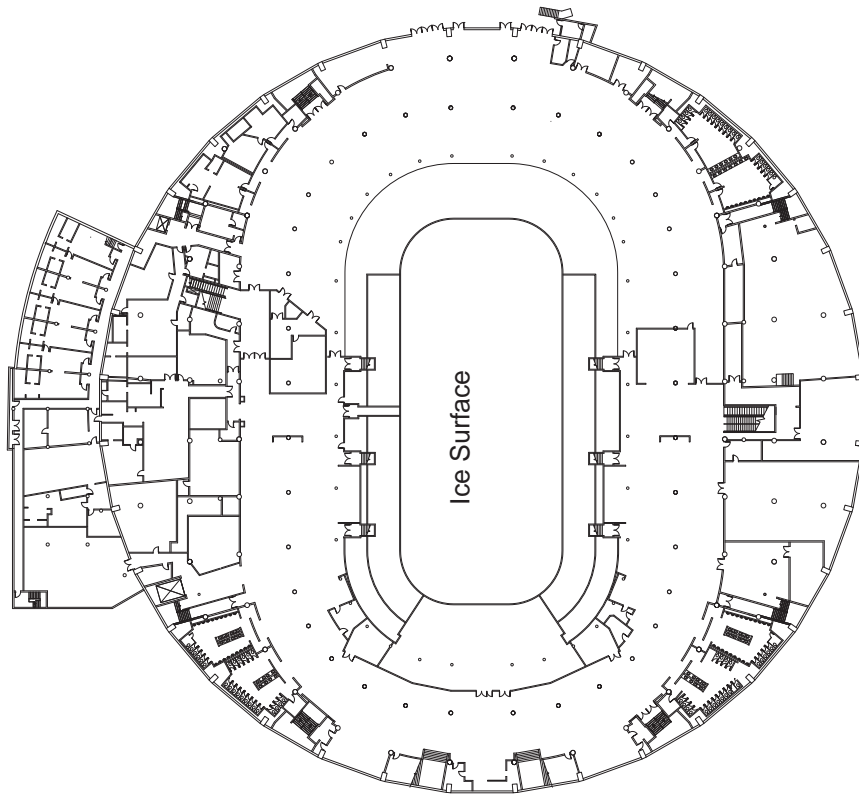

Rexall Place - Existing Level One Floor Plan. from Edmonton Northlands

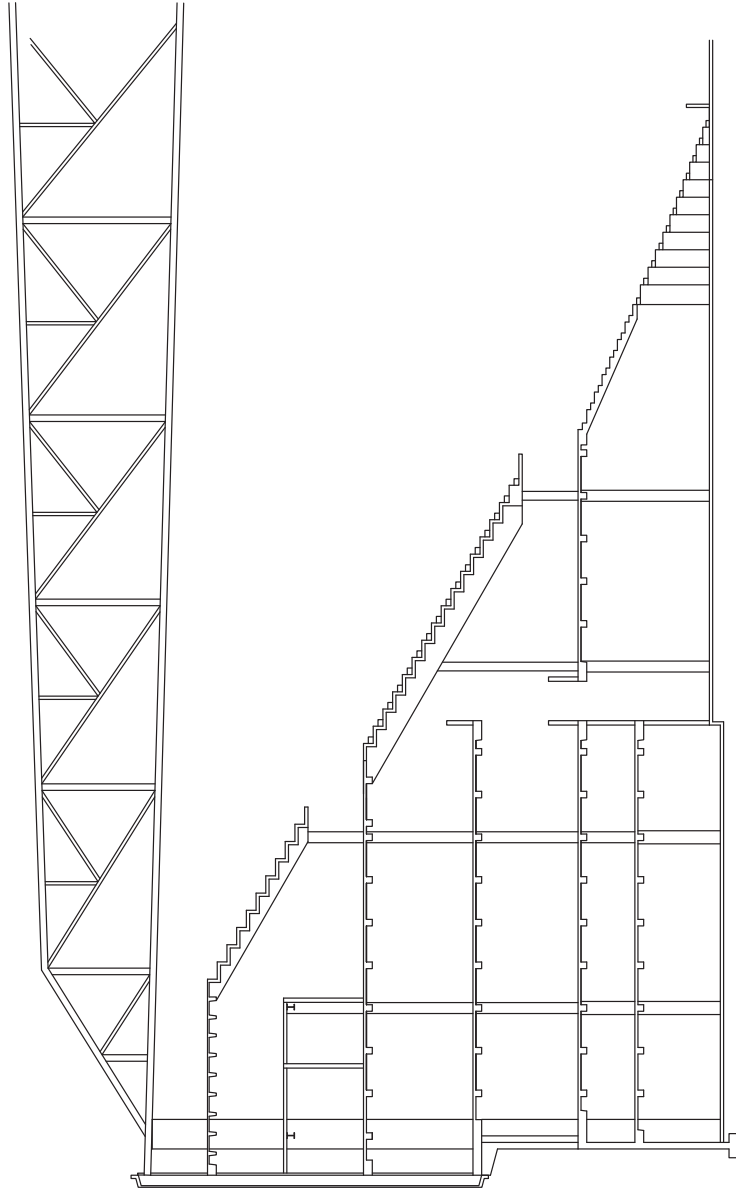

Rexall Place - Existing Building Section. from Edmonton Northlands

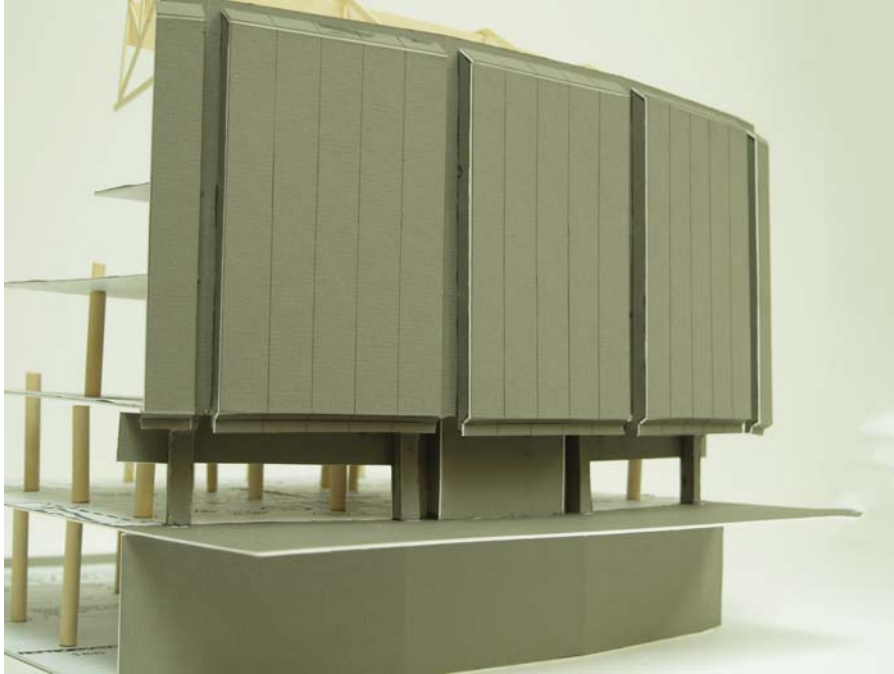

Existing building entry from LRT station

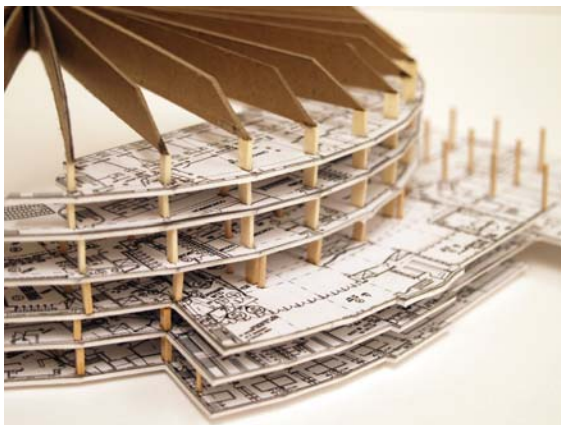

Existing main entry structural model

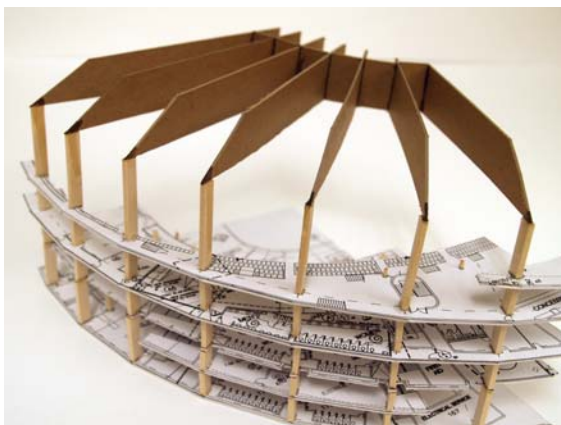

Existing structure at south west of building

REFERENCES

- Arsenal.com. 2011. Highbury Square (photograph). <http://www.arsenal.com/history/arsenal-stadium-highbury/the-stadium-highbury-square>.
- blogTO. Maple Leaf Gardens Section (photograph). 2012. http://www.blogto.com/city/2010/10/the_maple_leaf_gardens_makeover/.
- Cantacuzino, Sherban. 1989. *Re/ Architecture: Old Buildings/ New Uses*. New York: Abbeville Press Inc.
- Carter, David M. 2011. *Money Games: Profiting from the Convergence of Sports and Entertainment*. Stanford: Stanford University Press.
- The City of Edmonton. Edmonton City Skyline (photograph). 2011. <http://www.edmonton.com/for-business/2103.aspx>.
- The City of Edmonton Archives, 10440 108 Ave. NW, Edmonton, Alberta T5H 3Z9.
- Culley, Peter, and John Pascoe. 2009. *Sports Facilities and Technologies*. New York: Routledge.
- Diamonstein, Barbaralee. 1978. *Buildings Reborn: New Uses, Old Places*. New York: Harper and Row Publishers.
- Diniawarie, Dawud. 2009. *Urban Living*. Berlin: JOVIS Verlag.
- Edmonton Northlands Facility Services, 7912-115 Ave. NW, Edmonton, AB T5B 4X3.
- The Edmontonian. Wayne Gretzky Statue (photograph). 2011. <http://theedmontonian.com/tag/wayne-gretzky/#.T3UJdzEgceU>.
- Elias, Norbert, and Eric Dunning. 1986. *Quest for Excitement: Sport and Leisure in the Civilizing Process*. New York: Basil Blackwell.
- Florida, Richard. 2005. *Cities and the Creative Class*. New York: Routledge.
- Google Maps 2011. Edmonton Northlands, Edmonton (map). <http://maps.google.ca/>.
- Jodidio, Philip. 2010. *Public Architecture Now*. Cologne: Taschen.
- Joubert, Marc, and Tihamer Hazarja Salij. 2008. *NL 28 Olympic Fire: Future Games*. Rotterdam: NAI Publishers.
- Katz, Peter. 1994. *The New Urbanism: Toward an Architecture of Community*. New York: McGraw-Hill Inc.

- Northlands Park Memories Worth Keeping. An aerial view of the Coliseum (photograph). 2002. http://www.northlands.com/memories/background/buildings_coliseum.html.
- Open Street Map. 2012. Edmonton Northlands, Edmonton (map). <http://www.openstreetmap.org/>.
- Pitts, Adrian, and Hanwen Liao. 2009. *Sustainable Olympic Design and Urban Development*. New York: Routledge.
- Robert, Philippe. 1989. *Adaptations: New Uses For Old Buildings*. New York: Princeton Architectural Press.
- Schittich, Christian. 2003. *In Detail: Building in Existing Fabric*. Munich: Birkhauser.
- The Seattle Times. The Richmond Oval - Before and After Games (photograph). 2011. http://blog.seattletimes.nwsourc.com/olympics/2008/07/11/heres_your_publicly_financed_a.html.
- Sheard, Rod. 2001. *Sports Architecture*. New York: Spon Press.
- Wikipedia. Rexall Place at Night (photograph). 2010. http://en.wikipedia.org/wiki/Rexall_Place.